

Copia o deseño xeométrico nas dúas bandas inferiores, emprega as regras
Colorea cun rotulador negro.

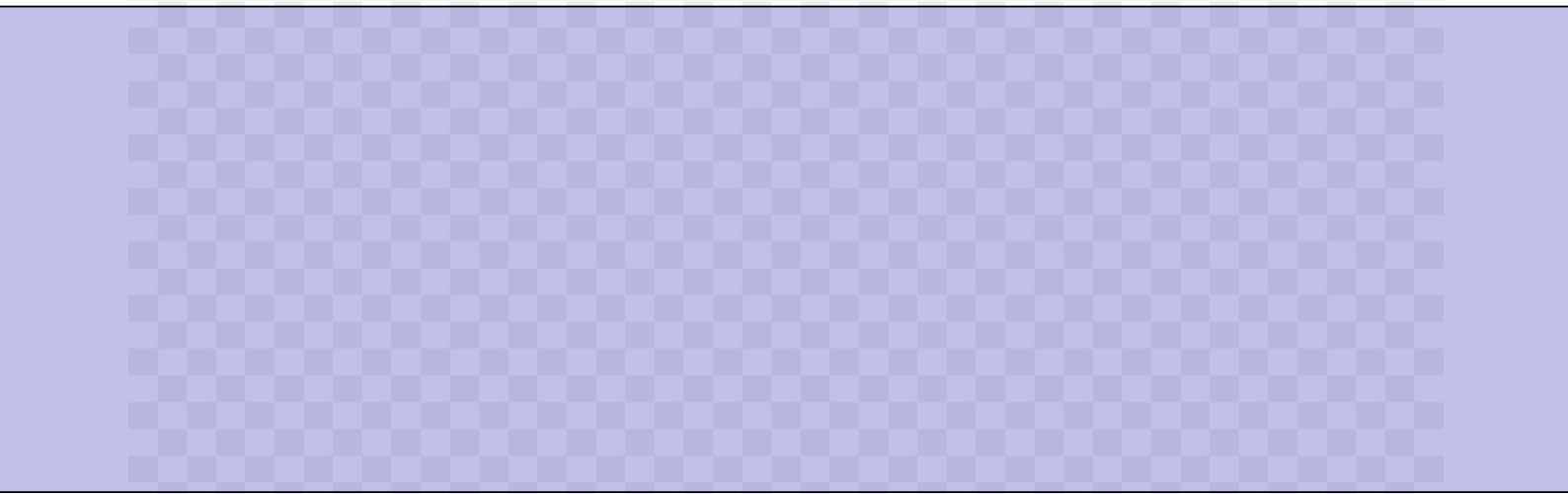

EMPREGO DO COMPÁS

- 1º nunha lámina do block fai circunferencias de radio 3cm, empregando únicamente o compás, fai a primeira circunferencia de radio 3cm e centro 0 según o modelo.
 - 2º coloca un punto 1 en calquera parte da circunferencia, fai unha segunda circunferencia de radio 2,5cm e centro 1. Obterás os puntos 2 e 3
 - 3º fai unha terceira circunferencia con centro en 2 (obterás o punto 4) e unha cuarta con centro en 3.....Fai circunferencias ata encher a lámina.
 - 4º pasa todas as circunferencias a tinta co adaptador do compás.
- ¡¡NON AS PASES A MAN ALZADA!!
- 5º colorea con rotuladores, ceras ou lapis de cores.
 - 6º fai unha foto ó traballo e envía como tarefa co título "emprego do compás"

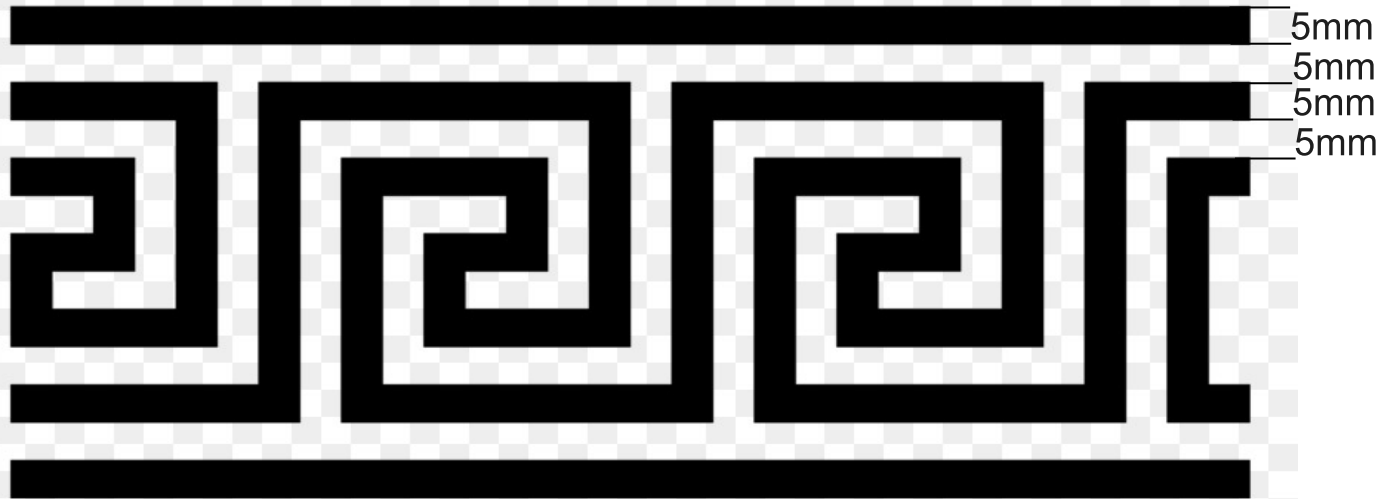
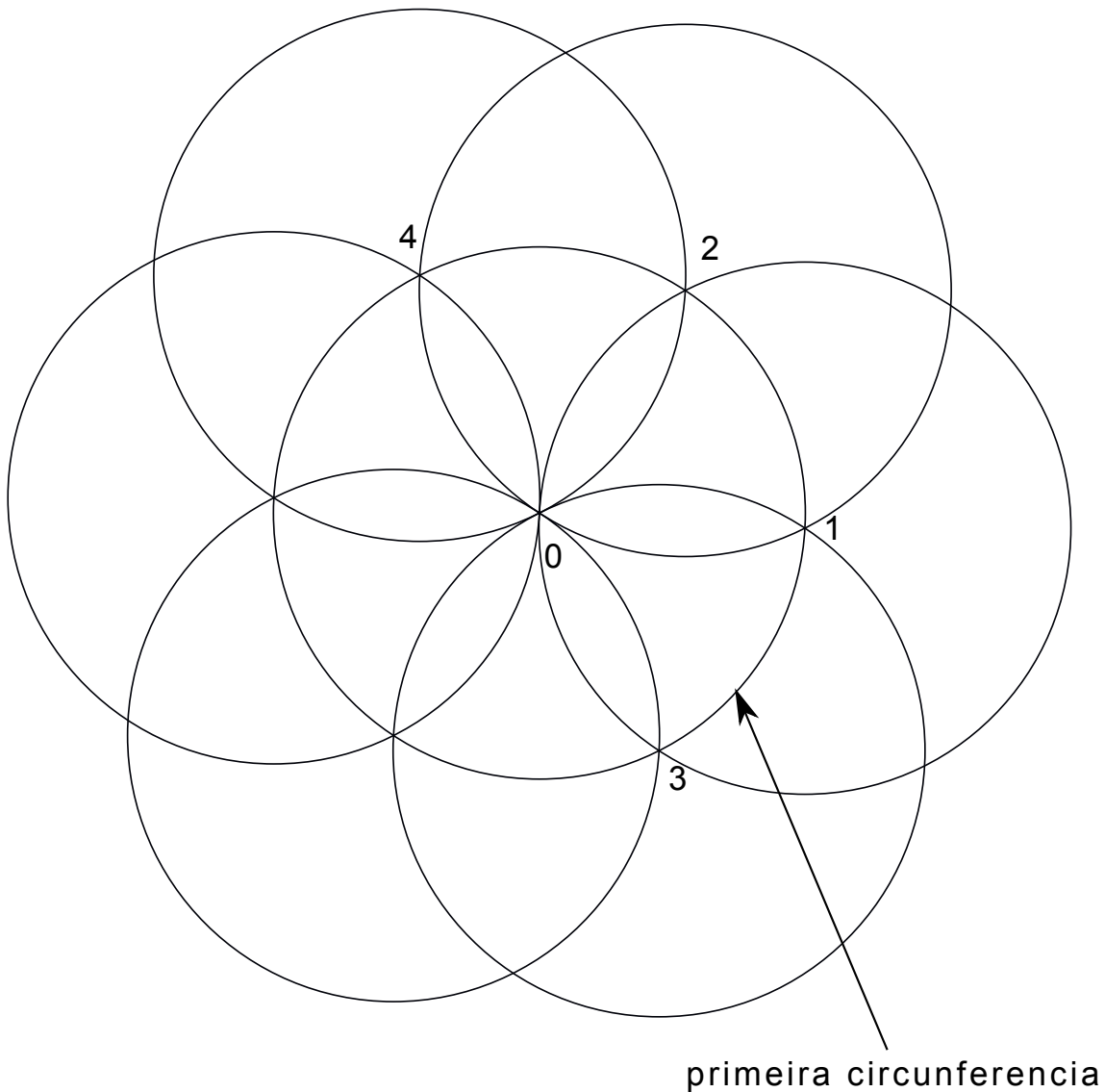

CIRCULO CROMÁTICO

- 1º fai unha circunferencia con centro en 0 de radio 9cm e divídeala en 6 partes iguais, cada parte mide 9cm
- 2º fai unha segunda circunferencia de radio 4cm. Une os puntos exteriores co centro das circunferencias.
- 3º fai un triángulo equilátero e divídeo según o modelo
- 4º colorea con témperas (MAXENTA, AMARELA, CIANO, BRANCO E NEGRO) faino como o exemplo e pasa todo a tinta cun rotulador ¡NUNCA A MAN ALZADA!

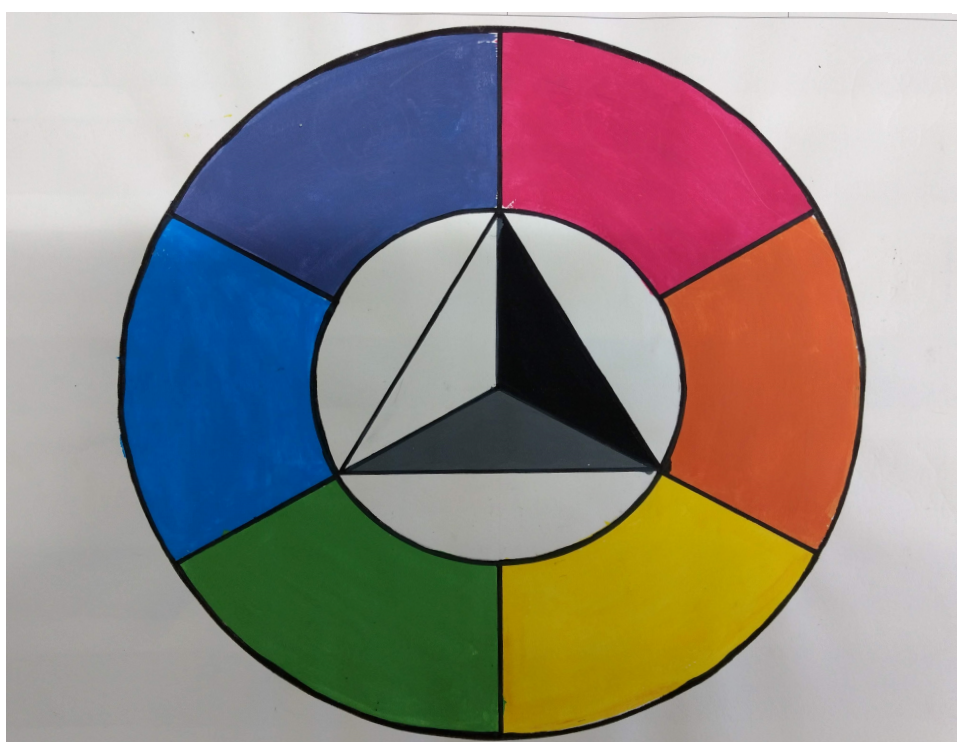
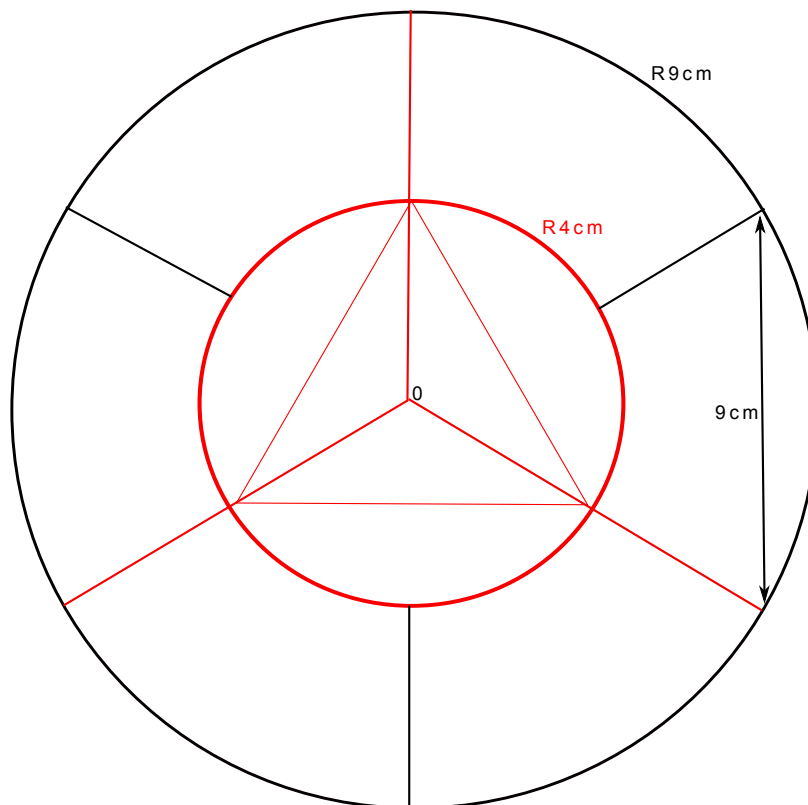

Debuxa o alzado, a planta e o perfil das figuras. Emprega as regras

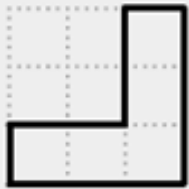

alzado



perfil

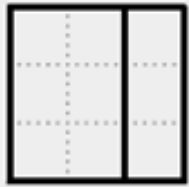

planta

exemplo

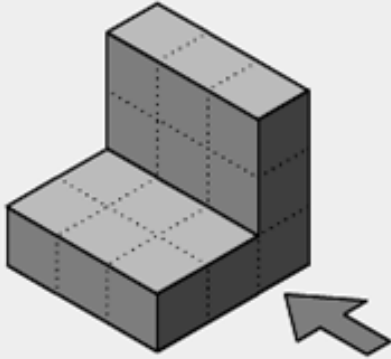

alzado



perfil



planta

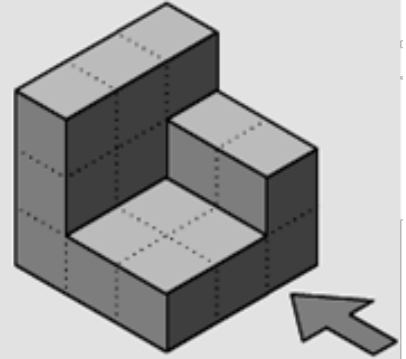

alzado



perfil



planta

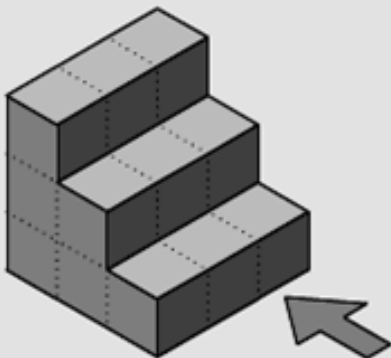

alzado



perfil



planta

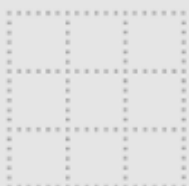
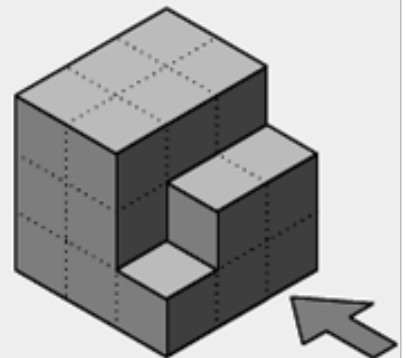

alzado



perfil



planta

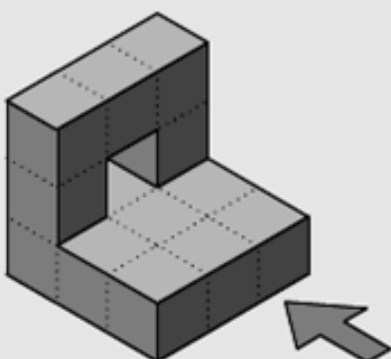

alzado



perfil



planta

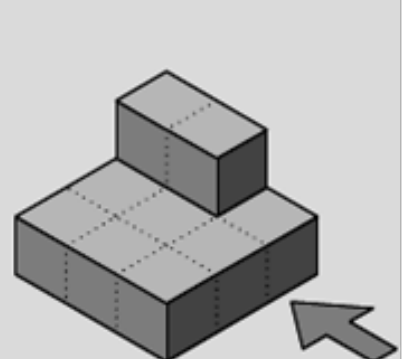

CORES CÁLIDAS E FRÍAS

1º enche os dous cadros anexos con pinturas de t mpera.

2º un deles faino con cores c lidas e outro con cores fr as.

B talle unha ollada as cores c lidas e fr as antes de facelo.

3º o rematar, recortaos e p gaos no block



Debuxa as expresións que aparecen nos exemplos variando os rasgos da cara variando os ollos, o pelo, as cellas...

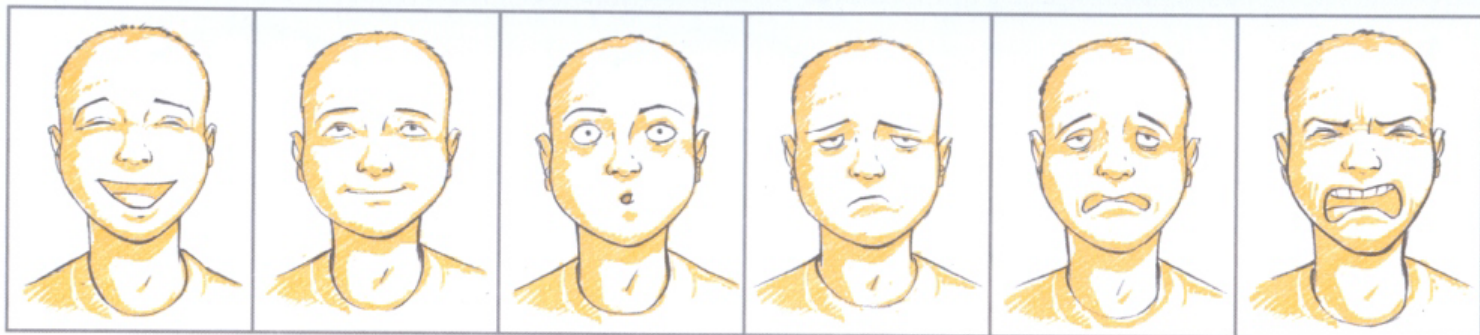

ALEGRÍA



ENFADO



TRISTEZA

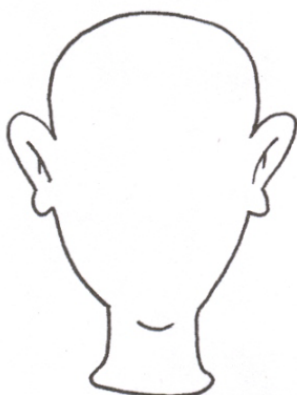

ABURRIMIENTO



MALICIA



INGENUIDAD



ASCO



FRÍO

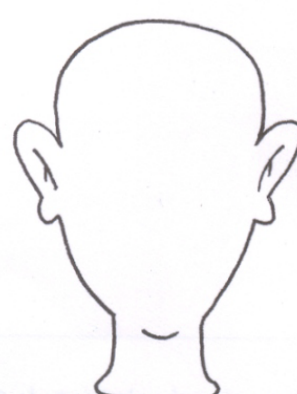

CALOR

1 cm

2cm

← 3 cm → ← 3 cm → ← 3 cm → ← 3 cm → ← 3 cm → ← 3 cm →

1,5 cm

2cm

azul
+ negro

azul

azul
+ branco

1,5 cm

2cm

verde
+ negro

verde

verde
+ branco

1,5 cm

2cm

maxenta

1,5 cm

2cm

1,5 cm

2cm

LÁMINA EMPREGO REGLAS E COMPÁS 3

- 1º FAI UN CADRADO DE LADO 10 cm, MARCA PUNTOS NO CENTRO DOS CATRO LADOS
- 2º FAI ARCOS CONCÉNTRICOS DE RADIO 3cm E 5cm CON CENTRO EN O_1 SEGÚN PASO 1
- 3º FAI DÚAS CIRCUNFERENCIAS CONCÉNTRICAS CON CENTRO EN O DE RADIO 3cm E 5cm
UNE OS ARCOS ANTERIORES COAS CIRCUNFERENCIAS CONCÉNTRICAS SEGÚN PASO 2
- 4º PASA A ROTULADOR E COLOREA. NON O PASES A MAN ALZADA!!

PASO 1

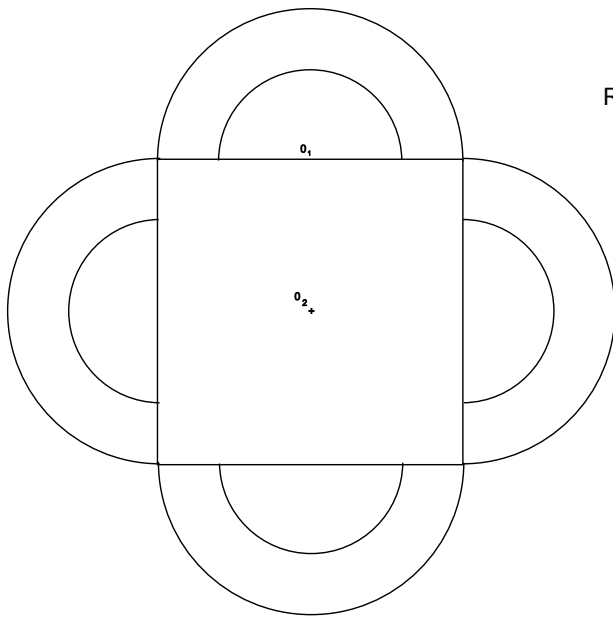

PASO 2

RADIO 5 e 3cm

