

# Hands-on Science

## Brightening our Future

Edited by  
Manuel Filipe P. C. Martins Costa  
José Benito Vázquez Dorrió

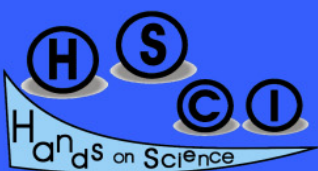

The Hands-on Science Network



# Hands-on Science

## Brightening our future

ISBN 978-989-8798-01-5

**Edited by**

**Manuel Filipe Pereira da Cunha Martins Costa, University of Minho, Portugal**  
**José Benito Vázquez Dorrío, University of Vigo, Spain**

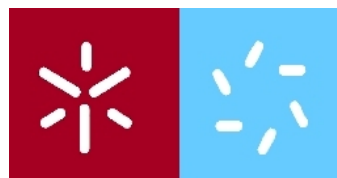

Universidade do Minho  
Escola de Ciências

Universidade de Vigo

The Hands-on Science Network



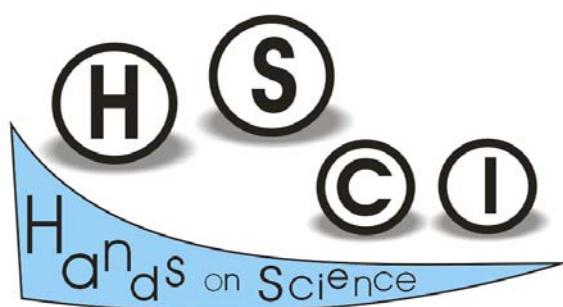

Copyright © 2015 HSCI

ISBN 978-989-8798-01-5

Printed by: Copissaurio Repro – Centro Imp. Unip. Lda. Campus de Gualtar, Reprografia Complexo II, 4710-057 Braga, Portugal  
Number of copies: 250  
First printing: July 2015  
Distributed worldwide by *The Hands-on Science Network* - [contact@hsci.info](mailto:contact@hsci.info)  
Full text available online (open access) at <http://www.hsci.info>

The papers/chapters published in this book are exclusive responsibility of the authors.

Please use the following format to cite material from this book:

Author(s). Title of Chapter. Hands-on Science. Brightening our Future. Costa MF, Dorrío BV (Eds.); Hands-on Science Network, 2015, Page numbers.

The authors of this book and the Hands-on Science Network, none of them, accept any responsibility for any use of the information contained in this book.

All rights reserved.

Permission to use is granted if appropriate reference to this source is made, the use is for educational purposes and no fees or other income is charged.



## **Foreword**

### **Brightening our future**

Light, either sunlight or coming from the moon or the stars, emitted by the fireflies or the bulbs in our room or coming out of our TV screen, is not only one of the first main vehicles of contact with the world around us but also adds beauty and fascination to our lives. Blessing all of us, it is definitely one of the corner stones of the structure of our modern world and crucial to its development.

In this Year of Light the main theme of the 12<sup>th</sup> International Conference on Hands-on Science was set to be the study of light, optics and its applications. By the importance of optics as major branch of science and by its numerous technological applications that make our everyday life easier and boost the positive prospects of development of our modern societies heading to a better brighter future for all humankind.

The book herein aims to contribute to an effective implementation of a sound widespread scientific literacy and effective Science Education in our schools and at all levels of society. Its chapters reunite works presented in this line of thought at the 12th International Conference on Hands-on Science held in Madeira Island capital city of Funchal in Portugal, July 27 to 30, 2015. From pre-school science education to lifelong science learning and teacher training, the large diversified range of works that conforms this book renders it an important tool for schools and all involved in science education and on the promotion of scientific literacy.

Vila Verde, Portugal, July 3, 2015.

Manuel Filipe Pereira da Cunha Martins Costa  
*Editor in chief*

---



## FOREWORD

## CONTENTS

<b>Why-, Ways-, Whom-, When- What- and Who- to Teach in Science and Technology</b> <i>PG Michaelides</i>	1
<b>Design for a Visit to an Informal Learning Activity at the University</b> <i>X Prado, S Lorenzo-Álvarez, XR Sánchez, BV Dorrió</i>	18
<b>Hands-on Experiments in the Formation of Science Concepts in Pre-school</b> <i>J Trna</i>	25
<b>Child’s Play or a Child’s Crucial Work? The Importance of Play in the Learning of Science</b> <i>S Dale Tunnicliffe</i>	30
<b>Efficiency of Inquiry-Based Education: Guided Research vs. ‘Blind’ Brainstorming</b> <i>A Kazachkov, M Grynova, JC Moor, R Vovk</i>	35
<b>Potential of Science Club Networks for Science &amp; Technology Popularization and Communication</b> <i>B Kumar-Tyagi, V Prasar</i>	37
<b>New Light to Relativity with Levers and Sticks</b> <i>X Prado</i>	49
<b>Students Become Mathematics Teachers</b> <i>L Sousa</i>	61
<b>Robots to Learn Statistics and Citizenship</b> <i>PC Lopes, E Fernandes</i>	70
<b>Recreational Angler Management in Marine Protect Area: a Case Study of Top-bottom Management</b> <i>F Encarnação, S Seixas</i>	79
<b>What Happens When Water Evaporates? An Inquiry Activity with Primary School Children</b> <i>P Varela, F Serra, MFM Costa</i>	87
<b>Exploring Probability Distributions with the Softwares R and Excel</b> <i>D Gouveia-Reis, S Mendonça</i>	95
<b>Hands-on Experiments and Creativity</b> <i>E Trnova</i>	103
<b>The Perception of the Population that Captures Mussels and Barnacles at Easter on Measures of Ecosystem Conservation</b> <i>M Jeremias, S Seixas</i>	110
<b>Studying Recombinant Protein Production and Regulation of Gene Expression in Genetic Transformed Bacteria using Fluorescent Reporter Protein mCherry: Molecular Tools and Procedures</b> <i>B Peixoto, F Sousa, S Pereira</i>	117
<b>Science Teaching in Primary School and the Importance of Interdisciplinarity in Knowledge Construction. Case Study: “Do Snails Prefer Cabbage or Lettuce?”</b> <i>P Varela, V Martins, A Moreira, MFM Costa</i>	124
<b>Syntax and Biology: a Teaching Experience with the Laboratory Notebook</b> <i>H Rebelo, D Aguin-Pombo</i>	131

<b>Development of Children’s Attitudes and Knowledge Towards Insects: the Pedagogical Role of School Visits to Exhibitions</b> <i>D Aguín-Pombo, A França, AV Bento, J Azevedo</i>	138
<b>Color, Light and Matter - the Simplicity of Metal Ion Complexes</b> <i>I Boal-Palheiros</i>	144
<b>Control of Carnivore Overpopulation (Egyptian Mongoose and Red Fox): Study Case in the Council of Azambuja (Portugal)</b> <i>M Teodósio, S Seixas</i>	150
<b>Hands on Action-Research in Construction of the Teaching Profession: A Scientific Contribution in the Initial Teacher Training of the University of Madeira (UMa)</b> <i>MFB Pestana-Gouveia, P Brazão</i>	156
<b>Hands-on Mathematics with Lego Robots</b> <i>S Martins, E Fernandes</i>	161
<b>Mathematics Higher Education with Interactive Computing Resources</b> <i>L Camacho, M Garapa, JNM Ferreira</i>	166
<b>“Think Global Act Local” - an Experience of Environmental Education for Sustainable Development on Special Protection Zone of Samouco Saltworks</b> <i>HC Carvalho-Pires, IA Pinto-Mina</i>	170
<b>Equilibrium and Stability in the Magnetic Field: Learning through an Out-of-Classroom Experiment</b> <i>D Castro, D Fernández, J Blanco, BV Dorrió</i>	175
<b>Developing Environmental Awareness of High School Students: 3rd Enka Ecological Literacy Camp as an Example</b> <i>ER Şükrüye</i>	181
<b>Learning to Be Critical with Mathematics: Body Mass Index</b> <i>S Abreu, E Fernandes</i>	184
<b>Discovering Light. The 5th Science Fair Hands-on Science</b> <i>MFM Costa, Z Esteves</i>	188
<b>The Euro4Science Forensic Science Education Toolbox – Demonstration of Beta Version</b> <i>L Souto, F Tavares, H Moreira, R Fidalgo, R Pinho</i>	193
<b>Euro4Science: Exploring Forensic Science Popularity to Promote Young People's Interest in Science and Technology</b> <i>L Souto, H Moreira, F Tavares, R Fidalgo, R Pinho</i>	197
<b>Modeling the Neuron!</b> <i>C Medeiros y Araujo, AS Lima-Marinho</i>	201
<b>Bio-Battery: Biomass Electrolyte</b> <i>M Firdaus-Nawawi, M Aziz-Khan, E Motius</i>	204
<b>Biodiversity and Species Extinction: STSE Inquiry Based Activities about The Consequences Induced by Volcanic Eruptions in the Tree of Life and in Travelling and Tourism by Humans</b> <i>C Sousa</i>	207
<b>The Scientific Concepts in Biology Textbooks</b> <i>M Ornelas, C Horta, D Aguín-Pombo</i>	209

## ABSTRACTS

<b>Designing Learning Scenarios with Robots for Hands-on Mathematics and Informatics Learning</b> <i>E Fernandes</i>	217
<b>Light and Shadows of Hands-on Based Education</b> <i>A Kazachkov, M Kireš</i>	218
<b>Chromium: the Keyword Towards a Web of Interdisciplinary Networks</b> <i>ML Pereira, TM Santos</i>	218
<b>Wind Tunnel in the Classroom</b> <i>J Pernar</i>	220
<b>A Study on Teachers' Perception about Educational Technology</b> <i>C Serdar, E Ceylan</i>	222
<b>Recreational Angler Management in Marine Protect Area: a Case Study of Top-bottom Management</b> <i>F Encarnação, S Seixas</i>	223
<b>Structuring Students Engagement in Inquiry-based Learning; the Process Is the Product</b> <i>A Suarez, F Prinsen, O Firssova, M Specht</i>	224
<b>Dependence of Fluorescence on Temperature</b> <i>B Mota, S Ferreira-Teixeira</i>	225
<b>Impact of Coastal Erosion in Portugal: Science Facts in a Television Documentary</b> <i>S Barata, M Serra, P Pombo</i>	226
<b>Using Socratic in Physics Courses for Immediate Formative Feedback</b> <i>N Balta, A Kaya</i>	227
<b>Science Motivation</b> <i>JC António, CMJM Marques</i>	228
<b>Access to Science and Technology by Women in India</b> <i>K Dasgupta-Misra</i>	230
<b>Arduino Science Kit: Open Hardware Platform for Science Activities</b> <i>P Ferreira, J Loureiro</i>	231
<b>Potential of Science Club Networks for Science &amp; Technology Popularization and Communication</b> <i>B Kumar-Tyagi, V Prasar</i>	233
<b>SCIENTOONS and Nanotechnology: a Science of Small Things for a BIG Change</b> <i>PK Srivastava</i>	235
<b>Interdisciplinarity in Physics Education - Study of the Potential Difference Generated by Oxi – reduction Reaction (Battery) with the Use of Computer Modelling</b> <i>Y Ulrich, A Machado, C Elias, A Santiago, L Pinheiro</i>	236
<b>"Ciência p´ra que te Quero": Making Science Accessible and Exciting to Young People</b> <i>MA Forjaz, M Maciel; A Alves, J Ferreira, J Marques, C Almeida-Aguiar, MJ Almeida</i>	237
<b>From Science to Consciousness: Why do We Need Clean Water</b> <i>MA Forjaz, MJ Almeida, M Maciel, A Nobre, C Almeida-Aguiar</i>	238

<b>Science Communication from Undergraduate Students to Children: Activities, Opportunities and Challenges</b> <i>J Ferreira, J Marques, MA Forjaz, MJ Almeida, C Almeida-Aguiar</i>	239
<b>Ionic Liquids Research and High School Students - In the Know and on the Go</b> <i>I Boal-Palheiros, AF Cláudio, M Freire, J Coutinho</i>	240
<b>Learning with Augmented Reality</b> <i>E Fernandes, PC Lopes, S Abreu, S Martins</i>	241
<b>Innovative Hands on Science Approach and Multi-pronged Communication Strategy to Dispel Myth about Nuclear Energy</b> <i>A Srivastava</i>	243
<b>Educational Project for the STAR Experiment at RHIC</b> <i>V Belaga, A Kechechyan, K Klygina, A Komarova, Y Panebrattsev, D Sadovsky, N Sidorov</i>	244
<b>Before versus After: “Word Clouds” as a Tool to Identify Adequate Key-Words Describing an Experimental Activity in a Chemistry Laboratory Context</b> <i>TM Santos</i>	245
<b>The Views of Teachers on the Practice of Technology and Design Lesson Programme</b> <i>C Serdar, E Ceylan</i>	246
<b>Student Attitudes Toward Science and Technology in Public Education of Chile. Approach to Diagnosis of Situation</b> <i>X Vildósola-Tibaud, K Santander-Prat</i>	248
<b>Active Learning in Optics and Photonics. Redesigning Circuits for the ALOP Workshop in Latin America</b> <i>C Chacón, F Monro, C Ramírez, AM Guzmán</i>	249
<b>Molecular Gastronomy. Pushing the Boundaries of Cooking through Science</b> <i>CS Alves, C Miguel, D Maciel, N Oliveira, H Tomás, J Rodrigues</i>	250
<b>Assessing the Impact of Medical Microbiology Classes Strategies on Short- Time Retention on Medical Students: an Innovative Study</b> <i>MM Azevedo, S Costa-de-Oliveira , R Teixeira-Santos, AP Silva, IM Miranda, C Pina-Vaz, AG Rodrigues</i>	251
<b>The Perception of the Population that Captures Mussels and Barnacles in Easter on Measures of Ecosystem Conservation</b> <i>M Jeremias, S Seixas</i>	251
<b>Control of Carnivore Overpopulation (Egyptian Mongoose and Red Fox) – Study Case in the Council of Azambuja (Portugal)</b> <i>M Teodósio, S Seixas</i>	252
<b>Developing Environmental Awareness of High School Students: 3rd Enka Ecological Literacy Camp as an Example</b> <i>ER Şükrüye</i>	253
<b>inGenious Project in my School</b> <i>E Vladescu</i>	253
<b>Evaluation and Comparison of Robotic, Mechanic and Programming Skills among 9 to 14 Years Old Children with and without Lego Education</b> <i>H Güvez, O Yılmaz, T Kamiş</i>	254

<b>Lessons Learned from the INSTEM Project</b> <i>A Sporea, D Sporea</i>	254
<b>Brightening the Classroom: Hands-on Organic LEDs and Solar Cells</b> <i>J Dörschelln, A Banerji</i>	255
<b>Hands-on Fieldwork</b> <i>R Freitas, A Baioa, R Borges</i>	255
<b>Hands-on Science in the Kindergarten</b> <i>S Santos, J Pescada, R Freitas, A Moura, D Ferreira, V Cavaquinho, R Borges</i>	256
<b>Mathematics Higher Education with Interactive Computing Resources</b> <i>JNM Ferreira, L Camacho, M Garapa</i>	257
<b>Science Outreach Activities at CQM-Centro de Química da Madeira</b> <i>H Tomás</i>	257
<b>Ars Lux laser Harp – the Musicality of Light</b> <i>A Lello, A Almeida, C Souto, R Rocha</i>	258
<b>Where Science Meets Oral Narrative</b> <i>M Condesso, P Pombo</i>	258
<b>Design and Implementation of a Remotely Controlled Physics Lab (RCL) Based on a Raspberry Pi: the Case of a Simple Optics Experiment</b> <i>G Mitsou, V Dionisis, J Karachalios, I Sianoudis</i>	259
<b>A Workshop on How to Create Sciencetoon and Making Science Learning a Joyful Experience</b> <i>P Kumar-Srivastava</i>	259
<b>Body Language to Understand Relativity</b> <i>X Prado</i>	260
<b>Teaching the Elusive Concept of a Photon</b> <i>AM Guzmán</i>	261
<b>Green Box Technique: New Way of Learning Method Improves Student’s Comprehension Skills</b> <i>E Sobaci</i>	261
<b>The Build-up of a National Community of Practice in Science Teaching</b> <i>A Sporea, D Sporea</i>	262
<b>Science Promotion among High School Students through PhD Student Chapters</b> <i>E Salvador-Balaguer, E Irlas, F Soldevila, RO Torres, AD Rodríguez, M Carbonell, C Doñate, J Pérez</i>	264
<b>Bridging the Gap: Chemistry and Biochemistry in the Real World</b> <i>N Oliveira, CS Alves, C Miguel, D Maciel, H Tomás, J Rodrigues</i>	265
<b>Chemistry is Fun: 20 Years Spreading Science in Madeira Island</b> <i>H Tomás</i>	266
<b>Nanoscience and Nanomaterials: a Science Fair Project</b> <i>CS Alves, C Miguel, D Maciel, N Oliveira, H Tomás, J Rodrigues</i>	267

## **AUTHOR INDEX**





## Why-, Ways-, Whom-, When- What- and Who- to Teach in Science and Technology

PG Michaelides  
University of Crete, Greece  
michail@edc.uoc.gr

**Abstract.** Within the technology dependent contemporary societies, the effectiveness of the teaching in Science and Technology is acquiring more importance. Many relevant empirical and theoretical works have been published as a result of an extensive on going research. In this work, features of different parameters in the teaching of Science and Technology are presented in order to exhibit the overall picture of the field. The work may be useful otherwise also as this communiqué was produced in an attempt to understand seemingly conflicting research results.

**Keywords.** Science, Science Teaching, Science education, Science and Technology Literacy.

### 1. Introduction

The welfare of our contemporary societies depends largely on Science and Technology (S&T) advances. However, only those whose skills include S&T Literacy may enjoy the benefits in full. S&T developments are rapid and coupled with a short time between a discovery (in ideas, in services, in technology) and its commercial implementation. As a result, the society is at large ignorant in S&T and cannot contribute, in a Vygotski context, to the required S&T Literacy, which, thus, may be achieved only through school education. This generates the need for an effective S&T school education and leads to continuing Education reforms elevating S&T education to a major component of school curriculum, comparable to language. Although the related theoretical and empirical research work is prolific [1], my feeling is that in most cases these education reforms are limited to changes in the syllabus (usually adding more themes), in the presentation of the themes i.e. by using the Information and Communication Technologies (ICT) or in the training of teachers to different teaching approaches. However, Teaching is a process, which, in order to be effective, many factors should be taken into account. This is especially true for the teaching in S&T where

experiments and laboratory practice is required. In this work, we *remember* (briefly) some aspects of these different factors that may help the planning of an effective teaching in S&T.

### 2. Why Teach Science and Technology

A sound planning of teaching, especially in the areas of S&T, requires a clear understanding of the objectives for the specific teaching. This is essential because the answer to the questions 'Why to plan this specific course? – What is the reason to include S&T in the School curricula?' defines, more or less, the appropriate choices for the other factors.

In general, the objectives set for the Teaching in Science and Technology fall within the following contexts.

- i. **Cultural.** S&T is a cultural asset of human civilization therefore it has its place in schools, especially in (early) compulsory education in which the prominent objective is the social inclusion of the future citizens. Within this context the importance is to raise awareness about the S&T advances and, possibly, about their consequences to the society. Failing to observe this has many disadvantages [2].
- ii. **Utilitarian.** Science is the basis of technology and thus a sine qua non for our technology dependant societies. It is also a necessary and significant means to technological progress and thus to welfare. This objective prevails in Technical Vocational education and is also dominant in Higher Professional Education. Within this context, details on facts and data on specialized themes and an intensive laboratory work and a workshop practice [48] together with an in depth theoretical framework are necessary.
- iii. **Personal development.** S&T poses inherent advantages to the cognitive development, especially for young persons. Consequently in primary education, where a major objective is the development of cognitive skills, the teaching of S&T should be a major component of the curriculum [3]. Within this context, teaching approaches should include problem solving, inquiry based or project based techniques. It must be stressed that an effective implementation of this context objective is very appropriate

for the development of logic, an advantage for the education of young persons, the future citizens.

- iv. **Social.** The proliferation of S&T products, services, etc. in everyday activities changes social ethics and leads to the introduction of appropriate legislation. To preserve our Democracies as an active citizens' participatory system, S&T Literacy is essential in order to understand introduced legislation and to choose between alternatives [4]. This implies also that S&T Literacy within this Social objective should constitute (according to UNESCO [5], [6]) a major component of the civil right for a quality education. This objective is closely related to the development of a knowledge-based society and poses specific demands on the required instruction design.
- v. **Educational.** S&T Teaching may be effected through an educational environment for cross-thematic and/or interdisciplinary teaching. S&T teaching within this context has acquired attention rather recently although related teaching practices are used in schools but within education in other subjects (for example, in art teaching, techniques of painting use properties of colour mixing, of epipolar and projective geometry, etc.). In other cases, advances in S&T are used as a more effective means of teaching (see examples in [7], [8]). Within this context, the starting point of instruction is the observation of a natural phenomenon, which then is processed according to the subject, and the skills dexterities pursued. As natural phenomena are directly perceived by senses, this method is appropriate for persons in their early cognitive development i.e. young children. Results from an integrated science-literacy instruction may be seen in [9].

The context objectives above may refer to any subject of teaching. Which one prevails in a specific system of education depends on the values and priorities of the relevant society. In different education systems, more than one of the above context objectives coexist and, depending on the values and the perspectives prevailing, the context society assigns different priorities to them (see more in [10], [11], [12]) affecting thus the emphasis on the way S&T is taught, for example:

- If the priority is Utilitarian, facts methods and techniques should prevail in the instruction.
- If the priority is Personal development, complex cognitive skills have to be developed e.g. by problem solving, inquiry or project based learning with the syllabus focused on general principles and models.
- If the priority is Social, project work and group work are useful resources with the syllabus focused on implications of S&T advances to the society.

Our societies highly value the Personal development and the Social context objectives and have also declared an interest on the Utilitarian one. The Cultural context objective is necessary for the continuation of our societies while the Educational context objective may prove a useful and effective teaching tool. Consequently, a balanced mixture of all these context objectives should be used. Towards this, S&T seems to excel other subjects, especially on **iii**, **iv** and **v** [3]. Thus, there is a need for an effective S&T education, especially in compulsory education, in order to change for better (improve or at least not deteriorate) the quality of our societies [13].

Concluding, for primary education where students are in the concrete operational stage of cognitive development, S&T is the most, if not the only, appropriate subject for all the above context objectives, as the phenomena are perceptible through the senses and involve minimal abstraction intelligence.

### **3. Ways to teach S&T**

As with every other subject, instruction in S&T may be effected through a variety of teaching instructions. However, in S&T there are some 'sine qua non' prerequisites, such as the observations of natural phenomena, the experiments in the laboratory and/or the practice in workshops, etc. Even within a simple context of a Cultural objective, where narration may be considered sufficient, S&T Teaching has to be related with, at least, observations of the natural environment. These prerequisites, although intrinsic to S&T Teaching, are sometimes ignored, may be because they are considered 'a waste of time' or because they require skills and dexterities from the teacher and the students or simply because they are considered 'difficult' and/or

beyond the abilities of the students, a statement reflecting the difficulties of the teacher rather than those of the students. There are many teaching approaches that, in general, may be adapted for the S&T Teaching. Any such adaptation has to incorporate sequences of the following activities:

**a) Observe** i.e. collect evidence (measurements or other data) related to the theme under study from observations, from experimentation, from study of the literature, or by asking expert persons.

**b) Process** the evidence to:

i. Make them more understandable and explicable,

ii. Check on their reliability,

iii. Unveil existing patterns (relations) within these data.

**c) Hypothesize** i.e. make 'simple' rules to describe (or explain) the patterns located previously.

**d) Test** i.e. design the collection of new evidence (for example through more observations, through specifically designed experiments, from other's experimental results, etc.) to discriminate between different hypotheses produced in the previous step.

**e) Conclude** i.e. based on this new evidence, infer conclusions on the validity of the hypotheses considered and, if necessary, adapt them to the new evidence, repeating in this case the previous step.

**f) Retrospect** i.e. review and reconsider the inferences and, if necessary, re-enter the process at the appropriate step

**g) Generalize** i.e. make reasonable guesses on the validity of the conclusions inferred e.g. if they are valid outside the specific situations where the evidence was collected ('define their extent of validity'), the conditions that may possibly invalidate them (e.g. accuracy of the observations, 'hidden' parameters, etc.).

**h) Communicate** i.e. produce an appropriate way to communicate the results of their study.

The above sequence of teaching activities is known with the, rather unfortunate, term of 'The

Scientific method' (the term 'Scientific Inquiry' is also used). Popper [14] has commented it epistemologically, initially in its first form (Observe, Hypothesize, Test, Generalize) and more extensively later.

When preparing a teaching instruction using steps of 'The Scientific method', the following may be found useful:

1. The whole teaching approach should be organized to actively involve students' participation – learning is a participating experience. In every step time for deliberation and reflection must be provided.

2. Gathering evidence means empirical evidence in the form of data (e.g. a temperature indication) or in a descriptive way (e.g. at 0°C ice was formed) and not otherwise (e.g. interpretative 'it is freezing'). This is essential in order to differentiate between the observation, which can be repeated and observed also by others, its subjective notion and its interpretation, which may not be unique. Interpreting the observations has a place in almost all other steps. The differentiation between data and their interpretation is useful in cases where the evidence is collected by asking people or by library-document search. It must be stressed that S&T is not quantitative data only – any such data should be checked within their context using judgement. Mastering this process denotes development of cognition as intellectual skills (e.g. 'discriminations') and verbal information (facts and labels – knowledge bodies) as they are defined in Gagné's Conditions of Learning Theory [15].

3. Transforming 'observations' into 'data' requires an intellectual exercise in order to differentiate what is relevant to the issue under study and leads to the development of complex ('higher') intellectual skills (Concrete concepts, Rule using, Problem solving) as is the case with the other steps. It may also result in wrong judgement hence the necessity to check the validity of data, a very fruitful process [16] ('learning from mistakes' may lead to a better understanding of the issue under study).

4. Collecting evidence through observations or by contacting experiments, especially when the guidance is not too detailed, is

advantageous because it activates the necessity to make successive decisions (what-how-when to observe, what to select for the record, how to arrange equipment, etc.). This is an exercise in problem solving based teaching and develops intellectual skills and a deeper learning.

5. Direct observations from situations in 'everyday life' [17] help to raise awareness on the impacts of S&T advances in contemporary societies.
6. Direct experimentation with self-made equipment [18] may be effected within the general contexts of problem based, of inquiry based and of project-based learning [8]. These approaches use constructionist principles [19] and present many advantages, especially in the education of non-Science specialists. This step promotes learning levels of cognition strategy and of motor skills (when the students are involved in the construction of the equipment used) and it may increase students' self-esteem (see examples in [20]).
7. For the education of specialists in S&T when the arrangements of special observations and of laboratory and workshop practice with sophisticated equipment is indispensable, an understanding of the principles used to construct the equipment is necessary in order to assess its reliability and operational conditions. If there is previous related experience with self-made equipment this task is facilitated.
8. When direct observation or experimentation is not feasible, other alternatives such as videos, writings, simulations, etc. may be used. These are useful teaching tools and means, also helpful in situations with time limitations. Physlets [21] is an easy to use example. However, they might be biased towards the views and the interpretations of their creator.
9. Step **b)i** is useful for a better understanding of the evidence collected and for the practice of valuable practical dexterities as the reading and/or the construction of a graph, a map, a histogram, etc.
10. Step **b)ii** is useful for a critical thinking on the reliability of the evidence collected, on

'hidden' parameters (factors that may influence the data obtained – often they are exposed by repeating the evidence collection in 'apparently' similar situations).

11. In step **c)** it is crucial to avoid leading the students towards the 'correct' interpretation (theory) of the data. Instead, effort should be exercised to use creativity and invent as many as possible differing interpretations that could be tested against in step **d)**.
12. Step **d)** is appropriate for the improvement of ingenuity by the application of project-based learning. The design of 'fair testing' is one of the issues to consider. This activity when applied correctly (e.g. using project based learning instructions taking into account the previous notes on observations and experimentation) promotes learning almost at all levels.
13. In steps **e)** and **f)** the conclusions inferred should be based on the (total) evidence collected and may lead to 'multiple theories' even outside the established model. In this case the retrospection may be more useful in understanding the principles involved.
14. Step **g)** is a practice to inductive inferences valuable per se. It may also lead to a retrospective recurrence of the whole teaching experience that, if conducted appropriately, may lead to long-term learning.
15. Step **h)** is useful for the development of skills of communication through the use of various types of data representations (graphs, tables, histograms, etc.). This is a more advanced than step **b)i** and helps understanding the related means of communications used also in other circumstances.

'The Scientific method' raised constructive criticisms from Kuhn [22], Feyerabend [23] and Lakatos [24] whose arguments start from the point that this is not the only methodology in sciences and it is not a unique historical paradigm, even in Science. Followers have extended their criticism on other grounds, helping to improve the initial frame of 'The Scientific method' (Observe, Hypothesize, Test, Generalize) and understand better its aspects, but, sometimes, the critic is biased, unfounded or even outside the rationalism (as inherited

from ancient Greek philosophers and rediscovered in the Enlightenment). These criticisms mostly originated from a group of postmodernism deconstructionists, as they were called, claiming an 'ideology' of 'Humanism vs. Rationalism' [25] commenting on issues of Science for which they had little or no knowledge and have triggered the 'Sokal hoax' [26].

'The Scientific method' is perceived today not as a linear process from **a**) to **h**) but as a continuum [i.e. **a**) to **b**) to ... to **h**) to **a**) or **d**) etc.]. In this continuum, the entrance may be in almost any step. For example, in social sciences, theories were made and, when empiricism was introduced, these theories were tested (step **d**) above) while in Science step **a**) is usually the entrance. This continuum is also considered as a general course and in any of its activities the most appropriate method (i.e. teaching instruction for education or research approach for research) may be chosen. Within these refinements 'The Scientific method' is a useful teaching approach and, if applied correctly, promotes learning outcomes at all levels. However, its key importance is that it leads to the development of creative and of critical thinking, essential components for a rational reasoning. Other alternatives, especially in Science, would degenerate teaching into catechism or mystical initiation with dogma replaced by the 'Holy book of Science' with types of theological arguments (i.e. 'dogmas' without empirical proof) replacing rational (scientific) argumentation. Such an arrangement may seem comfortable for some people but leads to pseudoscience occurrences [27], to the retreat of rationalism and to the appearance of fallacies and superstitions. The use of the 'Scientific method' is also necessary for the dissociation between the empirical evidence with its interpretation and the personal beliefs with cultural behaviours - attitudes.

#### **4. Whom to Teach S&T**

As a cultural asset of our societies and as a significant component of the civil right for quality education, S&T Literacy should be addressed to everyone, irrespective of age or professional activity. Of course the objectives, the depth, the sophistication, etc. of the teaching differs according to the target groups:

➤ For the general public there is a necessity

for S&T literacy in order for citizens to be able to fully enjoy the benefits of the S&T advances and participate or, at least understand, the policies (and their impact) that are introduced to regulate the situation occurring from the use of these advances. Teaching in this case is focused mainly to familiarisation within the cultural and the social objectives. This has been identified as a necessity to our societies and special actions are being undertaken (see for example the actions Science for All, Science and Society etc. of the European Union).

- For technical, vocational and professional education teaching has to be detailed and in depth within the Utilitarian objective. Also, the rapid advances in S&T impose a continuous formal and informal training in order for the professionals to keep their competency and proficiency. This need for training, sometimes evolving to full re-education, has been recognized as a characteristic of the labour force conditions and is heavily subsidized in the European Union and in other countries.
- For school and preschool education the objectives are adapted to the specific education system. In many countries there is a preference towards the Cultural, the Personal development and the Social objectives humanities prevail sometimes exclusively although, as is argued later, S&T literacy is equally important.

In any of the above instances, the teaching approach selected should match the objectives and the profiles of the students.

#### **5. When to Teach S&T**

The description in the previous section implies that teaching S&T is appropriate or even necessary, at all ages. Here some notes focused on young schoolchildren's (juveniles) S&T education are presented, mainly in the form of personal opinions and viewpoints.

It is often stated that Science, especially within a disciplined context of 'The Scientific method', requires logical abstraction (formal logic) and is beyond the ability of juveniles thus S&T education is not suitable for them. Nevertheless:

➤ Infants and young children seem to have an

increased ability to adapt and respond to changes in their physical environment successfully almost always (or at least after a first experience). It is the way they assimilate social knowledge and behaviours, the use of tools and objects in their everyday life and form their character and beliefs to construct their own representations of the surrounding world.

- Observations made by children may often be unsystematic or unrelated to the subject under study. Even if they seem unreasonable, they do have logic and it is the task of the teaching and guidance to intervene leading to learning and to the development of cognitive skills. This intervention however has to be in a rather delicate way in order to: a/sustain children's self-esteem and interest, b/avoid implanting superstition (of the type 'irrespectively of what you child believe the correct dogma is so and so'), and c/encourage and improve the creative thinking of children.
- In kindergarten quite often there are activities such as painting, paper cutting – gluing and other simple constructions.
- Children are observant to their physical environment and its changes and, when asked, they provide 'explanations' reflecting their representation of the observations.

The comments above, even if they reflect low rates, indicate that in early childhood, physical environment observations and changes are feasible invalidating, at least partially, the acceptance of non-suitability. Within the context of an S&T course to pre-service primary school teachers using Educational Robotics as education environment, some students undertook the task to teach a 'Robotics' course to primary school students [7]. They used hands-on activities with a mentor type guidance [28] in which the teacher plays the role of a member of the students groups exploring the situation together with the students. The school students responded immediately to the construction of the robot artefacts (when they had previous experiences with the Lego© bricks) and very well to the programming part of the robot artefact advancing from 'trial and error' attempts to more sophisticated approaches, indicating an understanding of the subject, which, however, was not reflected neither in the

worksheets they filled during the course nor in the discussion followed. This apparent inconsistency was resolved when it was realized that school students of this age used loose expressions and metaphors to describe their thoughts. Perhaps this non-use of the correct technical terminology has contributed to the acceptance of non-suitability of the 'hard sciences' to small ages (see also in [29]). Furthermore, although there was not within the scope of the test teaching, there was indication that students changed their previous perceptions about robots.

In my opinion, S&T education to juveniles, even at pre-school age is feasible, although difficult to be done properly, when attention is given to points such as:

- Youth tend to move around continuously with small periods of intense and focused thinking. Consequently teaching should be organized in short timed actions preferably with hands-on activities.
- Exploring their curiosity, any step of 'the Scientific method' used should be in a general exploratory way leaving the children to 'discover' every time the teaching environment that is either prearranged by the teacher or, preferably, set up within a teacher-students teamwork. This will keep their interest alive for longer periods helping them to participate actively in the teaching activities. Lecturing them to impose 'correct knowledge' is simply wrong. Guidance should be preferably within a mentor type context as youths usually reject authority.
- Teaching activities should focus on prior beliefs and perceptions guiding children to shape them in reference to their observations. This is a difficult task because it requires scaffolding and quite often, may confront with home-established beliefs, especially in multicultural classes.
- Teaching should encourage and inspire the 'discovery' of relations between the different results from the teaching actions. Such relations may be in the form of mapping (e.g. one to one, one to many, many to one, many to many), cause and effect sequences (e.g. heating melts substances), classification e.g. locating similarities and differences in objects (including living species), in ideas, in shapes, in processes,

etc., time changes (in a person, in the environment, etc.) and so on. When such a relation is against previous conceptions it provides ground for a fruitful teaching. However if it is against strong beliefs of a student it may become insulting and needs delicate treatment.

- Concepts are associated to names. In this association, the correct terminology should be respected and explained. Spotting differences in the meaning of a word (for example force, energy, work) within the context of Science (i.e. when this word is used as a 'technical term'), and the meaning of the same word in everyday life is advantageous in promoting intellectual skills and helps to avoid misunderstandings that lead to misconceptions or to alternate conceptions. The explanation must be extended also to 'technical expressions', for example to 'flow' in 'energy flow' or in 'heat flow'. The need for explanation is more imperative in languages where the words used as technical terms existed before their introduction as a technical term or expression.
- The choice of the issues to be taught (the 'syllabus') should meet the age and experiences of the children (see next section) with the teaching activities carried out preferably using simple and easily understood tools of everyday life. The use of sophisticated equipment may distract attention from the main issue and may give the impression that 'Science is complex and/or not for everybody'.
- Teaching activities may be organized either within the same (broad) topic (with the advantage of an in depth study within a context set-up once) or within (apparently) different topics (it may promote the skill of relating seemingly unconnected issues, a feature of creative - lateral thinking [30]).

Although most of the above may apply to any form of teaching, they must be given an increased attention when teaching children of small age as possible inefficiencies may give rise to erroneous perceptions persistent and difficult to change.

## **6. What to teach in S&T**

What and to what detail and extent to

teach is crucial to any teaching as it defines the (basic) learning level of 'Verbal Information' in Gagnè's taxonomy (the level of 'Knowledge' in Bloom's taxonomy) on which more complex cognitive skills and dexterities may be developed.

The creation of appropriate S&T syllabus must take into consideration the following:

- The Syllabus should be specific to the intended teaching with the chosen titles (issues) clearly described in order to define the detail and the extent to which they will be taught. To define the syllabus indirectly through the school textbooks and enhance them with more chapters according to S&T advances until the volumes are unmanageable at which time 'axing' is performed is quite inadequate although a common practice in the past (still surviving sometimes).
- Every syllabus is advisable to be developed afresh within the context objectives of the course, i.e.:
  - For a general awareness course (addressed for example to the general public) it will include as many topics as the available time permits, be limited to notions, applications and implications to society and be connected with everyday activities, omitting 'technical details'.
  - For the development of cognitive skills the topics selected should match the age of the students, the availability of necessary equipment, etc.
  - For technical – vocational education the topics selected must include details and an emphasis to applications. Likewise, for professional education with the inclusion of a strong theoretical foundation added.
- The curriculum should reflect the 'state of the art' in the following ways:
  - For every issue selected, the description should be in a 'state of the art' context and be presented in a consistent way, especially in compulsory education. The usual practice to present the syllabus in its historical evolution is inconsistent to the mentality of students and their experiences. Moreover this path 'imprints'

students understanding of Science with perceptions differing from what they are taught later resulting in a mental confusion.

- The practice to use models from the past to smaller ages (perhaps because they seem simpler) requires conceptual changes later in order to accommodate the current model. For example, 'Heat' is presented within the context of classical thermodynamics (simplified or not) with the 'flow of heat' being the key notion leaving the concept of 'thermal (or chaotic) motion' to a later stage, perhaps to a University or to a specialized course. This may explain why 'Heat' is considered as a most difficult to understand subject with many persisting misconceptions and alternate conceptions, many of them within the notion of the Heat as a fluid flowing between objects ('caloric fluid' [32]). When later thermal motion is introduced as a model for Heat, there are difficulties and misconceptions even for students of Physics at University level. My opinion is that this is due to their previous and persistent ideas (see [33], [34], [35]).
  - The curriculum must include recent advances and discoveries at least in their conceptual form. It is unacceptable a century after the theory of relativity and quantum mechanics to hear from 'gossiping passages' in (text) books or newspapers instead of learning about them in school. The argument that this is too difficult even at University level seems valid if limited to teaching professional knowledge. However, test cases from conceptual teaching of modern Science subjects have shown encouraging results [36], [37].
- The history of Science may be useful epistemologically but in S&T courses it makes little sense to include it as assessed material. It may be useful sometimes in (advanced?) S&T technical-vocational courses in order to compare different techniques and in other analogous contexts.
  - For every syllabus issue chosen, the detail, the extent and the implied instruction should observe the parameter of the Proximal Development Region, introduced by Leon Vygotski (see [38] for a collection of studies).
  - The development of complex cognitive skills requires time for deliberation and an in depth analysis of the subject studied, thus the choice of relatively fewer subjects with an in depth study seems more appropriate for smaller ages where cognitive development prevails. In technical-vocational education coverage of more subjects with details on facts, data and applications is advisable. In courses for general literacy many subject with only basic details and with aspects of their impact to everyday life should be chosen. In every case a balance should be exercised between the extents to which subjects are studied, the detail of the study, the impacts to society, etc.
  - It is a good idea to accompany the syllabus with teachers' assistance, for example in the form of teaching guidance, of textbooks, of identifying specific issues (e.g. conceptual difficulties, common alternate conceptions and misconceptions, difficulties or potential risks in experimentation), etc. This is required (especially where a system for the assessment of teaching is missing) otherwise teachers using their initiative, qualifications, goodwill and beliefs will make their own selection and may omit important parts (in S&T these refer usually to more modern subjects) or teach them inefficiently (for example as a newspapers' article of general information instead of a teaching tailored to the objectives of the specific course). Think, for example, what you have actually learned in school about quantum mechanics and relativity or about more common subjects as electromagnetism and heat or where did you hear about particle physics, strings, the Higgs boson (alias god(damn) particle [31]), a knowledge of more than 50 years old.
  - In the preparation of school textbooks the phrasing of the text, the pictures and the character of the textbook should be given special attention:
    - The phrasing is within the technical vocabulary of the topic described. This is necessary as it is part of the technical terms of Science. However in many cases the actual meaning of the phrase



has to be explained. For example: 'electric current' does not mean that the electrons or the electricity or whatever else moves like a water stream; 'heat flow' does not mean that heat is a liquid that flows from one body to another. Failing to explain the actual meaning, especially during the teaching to small ages, seems to foster misconceptions. The situation is more difficult than it appears because, in small ages especially, the language communication skills are not fully developed so teaching should be made with a phrasing from every day life and this phrasing is connected to perceptions not always consistent with the notions of the Science model used.

- The pictures used to clarify the text should match, as much as possible, the actual scales of the world otherwise explanatory remarks should be added. For example in pictures of the solar system (or of the atoms in the Bohr model) an explanation about the distances between sun and planets (or between the nucleus and the electrons) and the drawn dimensions of the planets (of the electrons) accompanying the picture may help to grasp the very large (or very small) dimensions'.
- Textbooks as a knowledge reference tool (where topics are presented) and textbooks as a teaching tool to be used in the classroom (usually containing teaching guidance and samples of course worksheets) serve different purposes and should be produced with different specifications. Mixing these purposes in the body of one book requires great effort in order to have the different purposes clearly indicated.

Finally, for every teaching planned, it is advisable to develop the syllabus afresh. Using syllabus prepared for another teaching may risk mismatches and situations incompatible with the course objectives.

## **7. Who to Teach Science & Technology**

The effective teaching in any subject requires a variety of qualifications from the teacher. On top of these 'general' qualifications, additional demands are posed on the S&T

teacher e.g. skills of observation, of experimentation, skills and dexterities of laboratory and/or workshop practice, etc. In the pursuit for an effective education, in general and in S&T, a wealthy and growing number of theoretical and empirical works have appeared (see for example in [39], [40], [41] where results from theoretical and empirical research may be found). The efficient S&T school teaching is a necessity to our technology dependant and knowledge based societies because, due to the rapid developments in the field:

- Societies have not assimilated the advances and there is a lack of corresponding 'technology culture'. This culture may be promoted only through (school) education. This lack of technology culture is more prominent to the grown ups than the younger persons (for the case of Informatics see 'Digital Natives – Digital Immigrants' in [42]).
- Society's prevalent perception of S&T is within the scope of developing technical and vocational skills and dexterities, resulting in maintaining the gap of the 'two cultures' [2].

As a consequence of 'S&T ignorance', misconceptions, alternate conceptions and other teaching deficiencies are more frequent in S&T than in other subjects where some of the teaching deficiencies either do not appear or may be mitigated by the social environment.

Most studies on the characteristics of an efficient teacher refer to one specific parameter i.e. the subject matter knowledge, the teaching approaches adopted, the communication skills with the students, etc. From these studies, it seems that although every parameter counts towards an effective S&T teaching, it is the total profile of the teacher that matters and that none of the qualifications alone is sufficient although many are necessary.

In the reforms towards a more efficient S&T education, Teachers' development (training and initial education) has emerged as a key question. To answer this question the desirable S&T teacher's profile has to be determined, a rather complex task. In a school teaching experience, John, a middle school student answered the question 'how is a good (i.e. an efficient) school teacher?' as: *the one who knows and can teach the subject, who answers the questions even in a following teaching, who*

*does not say rubbish, who learns with the students not pretending knowing everything, in summary, when, children learn.* In my opinion this response provides a compact description for the profile of S&T teacher.

For the education and training of teachers various models have been adopted between two opposite approaches as follows:

**A.** Education with a strong psycho-pedagogic component and training to the 'basics' of the various disciplines (school subjects). This is the model used mainly for small ages including primary education where the emotional development is considered as the central objective of the school. In this model there is one teacher for all school subjects. As the subject knowledge of the teacher is rather weak (especially in S&T), this model has the drawback of possibly inducing incorrect understanding of syllabus topics, which will be difficult to correct in subsequent education, if any follows.

**B.** Education with a strong 'specialist's' education on a specific (broad) discipline and a basic (if any) training to teaching approaches. In this model there is a specialized teacher for every subject and it is encountered in secondary education, in technical-vocational education and in (professional) higher education where the main objective is detailed knowledge. As the teacher's qualifications in teaching are rather weak, this model may have the drawback of low learning levels achieved, especially in general education (middle and high school). In strong technical – vocational and in professional education this drawback is mitigated by the intensive laboratory and workshop practice, which provide a working understanding of the subject and relevant operational skills.

The models above do not answer the problem of transforming the knowledge on the subject and of the teaching approaches into effective teaching activities. Empirical evidence shows that this is not a simple straightforward task but involves special effort. Coupled with the need for continuous updates to the subject knowledge required by syllabus' changes, especially in the S&T area, the need for a continuous training of teachers has emerged and the models in use vary within the following general

approaches:

- C.** Detailed 'model teachings' on the syllabus' issues. Its drawback is that usually it is not possible to cover all the issues while it is also necessary to repeat the training in every syllabus' changes.
- D.** Training with emphasis to learning theories, teaching models and, possibly on specific points about issues of the subject matter (e.g. misconceptions and other difficulties of understanding). In this model it is assumed that the teacher will be able to transform the acquired knowledge into effective teaching activities, an assumption with unsupported evidence [43].

A problem that tampers with the efficiency of the previous training programs is that the training is 'out of the job' in specially prepared training centres, for example in Universities or in schools outside school hours, resulting in: a/a dissonance between the training and the actual school teaching planning depriving the teacher trainees of the practice within an immediate and supervised implementation of what they have learned, b/a disruption to the school program either because permanent teachers are replaced or because permanent teachers have to attend the training on top of their teaching, c/experienced trainers, especially in S&T, occur in low numbers and, also, they may not be aware of special conditions prevailing in the trainees' schools that impose a different to the training course teaching approach. Another effective in-school training model for the S&T teacher has been proposed in [44]. Parameters of this model have been tested with positive indications [45].

Other crucial parameters for the S&T teacher include:

- E.** What constitutes a sound knowledge of the subject matter for the S&T teacher, especially in view of the advances and the subsequent changes in the syllabus? It is evident that the traditional meaning of a detailed and extended to the whole area knowledge of S&T subjects is neither possible (even for professionals) nor necessary. Even if this knowledge is limited to the subjects actually taught in schools the continuous adaptations of the syllabus make

the effort fruitless.

**F.** If we suppose that the S&T teacher has the necessary subject matter knowledge is he – she able to adapt (usually to make it simple) to the level of his – her students? Existing evidence points that the S&T teacher mostly repeats the way he – she was taught meaning usually either narration or ‘complex’ mathematics (...we have verified ... in many cases that a student’s incapacity in a particular subject is owing to a too rapid passage from the qualitative structure of the problems ... to the quantitative or mathematical formulation ... normally employed by the physicist [46]).

**G.** In S&T School teaching, students often seem to have knowledge surpassing that of the teacher, i.e. in the use of specialized computer applications or from news reports etc. and the qualifications of the teacher should include the handling of these situations.

In view of the above I think that the education of the S&T teacher should take care of the following:

**H.** H. Focus on conceptual understanding of the subject matter. It may be achieved using simple understandable models for the natural phenomena studied [47].

**I.** The issues studied should represent natural phenomena closely with only the very necessary abstraction level. Otherwise Science may be distanced from the real world (think for example the simple frictionless kinematic taught in school and its resemblance to the real world). Although it seems a very complex task ‘to solve’ even simple phenomena, remember that a main objective of Science teaching in small ages is not to inform but to develop cognitive skills and this may be achieved within the context described in section 2-How to teach S&T.

**J.** In general, the teaching approaches used for the education and training of the S&T teacher should reflect the appropriate teaching methods in school. This way the teacher may repeat this kind of teaching as is suggested by the empirical evidence or if confronted with difficulties to make necessary adaptations in the classroom [43]. Within this context, the use of project based

teaching for the collection of evidence (observations, experimentation...) seems advantageous.

**K.** Depending on the level of education and on the objectives of the specific S&T teaching, appropriate adaptations should be made to the different steps of the ‘Scientific method’. For example, general education (especially if addressed to small ages) the collection of evidence should exploit the environmental context of the students associating everyday activities and phenomena to Science concepts [17] while in the technical-vocational and in professional education the literature review (e.g. from handbooks of technical data) may suffice.

**L.** A fundamental constituent of any Teaching in S&T is the laboratory and the workshop practice, which must be adapted to the objectives and the level of the specific curriculum through relevant activities organized with active participation of the students. For example, in general education the use of self-made equipment [18] seems advantageous e.g. when there is lack of equipment or of technical support, a situation observed in many schools especially in rural areas and in primary education. In professional education specialized equipment may be necessary. In awareness courses addressed to the general public demonstrations, computer simulations and video may suffice.

**M.** The teachers’ difficulty to transform knowledge into school activities may be moderated, at least in compulsory education which focus mainly to the students’ cognitive development and socialization, by organizing teaching activities for the education of teachers in two levels a/an advanced level for the teachers themselves, and b/a level more appropriate for school teaching. This organization covers subject matter and its didactics, i.e.:

➤ The collection of evidence through observations and experimentation may be delivered through ‘polymorphic’ teaching activities [49]. These activities include a common psycho-motive activity to collect evidence (e.g. make observations, take measurements, do experiments...) that consequently is processed through a morphing

appropriate for the different education levels and the objectives pursued.

- Using guidance in the form of mentoring is more advantageous to traditional tutoring [50] and, in case the teacher has difficulties to organize the instruction, it may balance teaching deficiencies if the teacher repeats it into classroom. This way, any insufficient knowledge of subject matter may also be managed. Mentor type guidance may seem as time consuming but I think that its advantages are far more. Besides, S&T Teaching aims to learning and to the development of cognitive skills and not just to transfer information.

It is evident that, within the context of S&T teachers' education and training, special attention should be observed towards the previous arguments a task not so trivial. Such an implementation is presented in [8].

## 8. Closing Comments

The effective Education in Science and Technology is a complex process depending on many equally important parameters. Due to the rapid advances in this area, which have not been assimilated by the society, an effective S&T education and training becomes crucial in order to sustain the welfare of our technology dependent and knowledge based societies. To this aim specific focused actions have been launched in all countries. Even, in actions focused to the technical, vocational and professional development of the work force, modules for a deeper understanding of the basic principles of S&T advances and their impact to the society are envisaged on top of the training. In my opinion, although these actions are necessary to keep the competences of the work force, a long term strategy must include specific additional measures focused to:

- The education of pre-service (would be) S&T teachers and the training of in service S&T teachers as discussed in section 7-Who to Teach S&T.
- The education in small ages including preschool (as discussed in section 4-Whom to Teach S&T).
- The general population with a two-fold aim:

a/to include them as beneficiaries of the S&T advances, and, b/to accelerate the evolvment towards an S&T conscious society – parents and the adults of the surrounding society pass their beliefs and attitudes to the new generation even before schooling.

- S&T teaching in schools, especially in compulsory education, should change towards methods promoting the active participation and exploring the imagination and creativity of the students as discussed in section 3-Ways to teach S&T.
- Subject matter in the syllabus should reflect the state of the art and be presented in a consistent way with the historical path of S&T evolution to exist only for 'good reasons' compatible with the course objectives as discussed in section 6-What to teach in S&T.
- Special attention should be given to Compulsory education (especially to Primary education) in order to balance the 'one-eyed' bias towards humanities that nurtures erroneous conceptions on S&T issues and enlarges the 'two cultures' gap. It will also have long term advantages because: a/it is the longest component of compulsory education, b/students in this age form their character and most of their cognition skills, c/the efforts for an efficient S&T teaching in Compulsory education will 'pay off' later making teaching easier (fewer erroneous conceptions to 'combat') and in society with more of the population being included to the benefits of the S&T advances. The ideas expressed in the previous sections (especially sections 3-and 7) may be useful towards this aim.
- In specialists' education (especially in higher education) the teaching is focused mainly (and correctly?) on Verbal Information and Intellectual Skills (Gagné's taxonomy) with the otherwise professionally competent teachers having, usually, little understanding of pedagogy (learning theories, teaching approaches...). Only recently high top higher Institutions have introduced pre-service training in these matters, mainly to raise awareness to the different cultural backgrounds of their students. More is required in order for the students, who will start their professional

career years later, to acquire long-term understanding in order to be able to cope themselves with the evolution changes they will encounter during their professional career.

- ‘The Scientific method’ is an indispensable tool towards a teaching in S&T when its steps are applied broadly as ‘general directives’, (especially in view of the last remark of section 3-) but without denying its purpose. To quote from [51] (the emphasizing is mine): ... *cultural understanding ... is not sufficient to ensure students' full participation in science ... teachers also require knowledge of the nature of science as defined by Western tradition. Such knowledge may be incompatible with the cultural values and interactional styles of some teachers and students ... the rules of science inquiry, including the use of empirical evidence, logical arguments, scepticism, questioning, and criticism, may be incongruent with the values and norms of cultures favouring social consensus, shared responsibility, emotional support, and respect for authority. In contrast, teachers who are knowledgeable about science, but not about the cultures of their students, may emphasize inquiry without making science relevant to students.* Note that cultural understanding and social consensus means the coexistence of different cultures and not domination by brute force of one on the others. If this is not a contemporary utopia, it may, possibly, be achieved through an effective education in S&T (see [52] for a Science teaching to students from different cultures).

Education in S&T has emerged as a key factor in our day with a plethora of research and on the field works appearing in scientific, educational and other journals, conferences, workshops... [53].

## 9. Acknowledgements

I thank Chairman of the Conference Prof. Manuel Filipe Costa who gave me this opportunity to present my views on Science and Technology Teaching. I also thank the organizers of this Conference for their patience in waiting my “manuscript”. I express also my thanks to my numerous students, who, tolerating me as their teacher, presented me

with a very interesting, joyful and motivating time.

## 10. References and Notes

All url addresses quoted here were visited on May 15, 2015

- [1] For a non exhaustive list of sources for the teaching in Science and Technology see references in: Michaelides PG. State of the Art of Science Teaching, Invited paper presented at the HSci2004 - 1<sup>st</sup> International Conference on Hands on Science: Teaching and Learning Science in the XXI Century; 2004 Jul 5-9; Ljubljana, Slovenia. Ljubljana: University of Ljubljana; 2004. Proceedings, pp.11-17 <http://www.hsci.info/hsci2004/>
- [2] Snow CP. The Two Cultures: A Second Look. Cambridge University Press; 1963. Its thesis is that British influence at WWII and afterwards deteriorated compared to Americans and Germany because their education system put emphasis almost exclusively on humanities ignoring S&T education on which the American and German education systems had put an emphasis; the result was that the British elite (politicians, government administrators, industrialists, etc.) were not adequately prepared for the challenges ahead.
- [3] In a Piagetian context, children in primary education are in the stage from concrete operational to formal. Natural phenomena (at least the ones in primary Science) are directly observable by the senses (or with the help of simple, easily understood, equipment) thus more easily perceptible than the phenomena (objects of study) in other disciplines where an abstract notion is necessary for their perception (for example migration apart from the observation of one or more persons relocating themselves, the subjective notion of permanently moving – making a new home- is also required). Because physical phenomena are usually perceptible by all normal persons they may provide a common reference system of notions, a truth, as Einstein in his “Lectures at Princeton” called it. Note that Piaget, founder of Cognitive psychology, was a prominent biologist and his works on

cognition originated from his observations on how his children perceived the Physical world. Also, many of the modern teaching tools and means are based on S&T advances, especially on Informatics with Internet providing a context for the teaching of many different subjects.

- [4] As we know it, Democracy is based on active participation of the citizens to the decisions taken and this participation should be through their own capacities and not as followers of a “gifted leader” (as ‘sheep under the herdsman’). An increasing number of decisions are dependent upon S&T developments (e.g. electronic transactions, electronic communication and socialization, electronic crime prevention, etc.). In order for the citizen to be able to participate on his (her) own he (she) not only should be S&T literate but also he (she) must have cognitive skills permitting decisions on incomplete knowledge, i.e. also in areas he (she) is not an expert. Otherwise science will be mixed with religion as in the Dark Middle Ages or in some places (for example in extreme theocratic regimes or in contemporary USA – see <http://www.ncseweb.org/> - where Science education, especially the theory of evolution, became a legal matter competing with religious doctrine). Within this context Science and Technology Education should be considered as a major component of the civil right in Education (a right to democracy).
- [5] Education for All, Global Monitoring Reports <https://en.unesco.org/gem-report/reports>.
- [6] Tate W. Science Education as a Civil Right: Urban Schools and Opportunity-to-Learn Considerations. *Journal of Research in Science Teaching* Vol. 38, No. 9, pp. 1015-1028; 2001.
- [7] Anagnostakis S, Michaelides PG. Teaching Educational Robotics for Schools: Some Retrospective Comments. Proceedings of the 9<sup>th</sup> International Conference on Hands on Science; 2012 Oct 17-21; Antalya, Turkey, 2012. p. 13-138. [http://www.hsci.info/ProceedingsHSCI2012\\_smallsize.pdf](http://www.hsci.info/ProceedingsHSCI2012_smallsize.pdf).
- [8] Michaelides PG. Problem Based Learning in Science and Technology teaching in the Department of Primary Teachers Education of the University of Crete. Proceedings of the 9<sup>th</sup> International Conference on Hands on Science; 2012 Oct 17-21; Antalya, Turkey; 2012. p. 112-119. ([http://www.hsci.info/ProceedingsHSCI2012\\_smallsize.pdf](http://www.hsci.info/ProceedingsHSCI2012_smallsize.pdf)).
- [9] Honig S. What Do Children Write in Science? A Study of the Genre Set in a Primary Science Classroom. *SAGE Publ., Written Communication* 27(1) 87–119, 2010. (<http://wcx.sagepub.com/content/27/1/87.full.pdf+html>).
- [10] Christophorou LG. *Kluwer Place of Science in a World of Values and Facts*. 2001.
- [11] Kumar DD, Chubin DE, editors. *Science, Technology, and Society: A Sourcebook on Research and Practice*. Kluwer Academic Publishers; 2000.
- [12] Russell B. On Education, Especially in Early Childhood, 1926 (*The education we desire for our children must depend upon our ideals of human character, and our hopes as to the part they are to play in the community... there can be no agreement between those who regard education as a means of instilling certain definite beliefs, and those who think that it should produce the power of independent judgement ... This is especially true of the first five years of life; these have been found to have an importance far greater than that formerly attributed to them, which involves a corresponding increase in the educational importance of parents*). See more in: <http://www.humanities.mcmaster.ca/~russell/>.
- [13] Aerts D, Gutwirth S, Smets S, Van Langehove L, editors. *Science, Technology, and Social Change*. Kluwer Academic Publishers; 1999.
- [14] See for example a/ Popper K. *The Logic of Scientific Discovery*. New York: Basic Books; 1961, b /Popper K. "The Aim of Science." *Ratio* 1. 1957; 24-35, c/ Popper K. *Conjectures and Refutations*. New York: Basic Books; 1962.

- [15] See **a/** Gagné RM. The Conditions of Learning and Theory of Instruction. New York: CBS College Publishing; 1985, **b/** Gagné RM, Driscoll MP. Essentials of Learning for Instruction. New Jersey: Prentice-Hall Inc.; 1988.
- [16] One of the critics of 'The Scientific method' is that knowledge is advanced through the 'errors' ('false results') rather than through the normal pattern supposed in its 'normal' 'Hypotheto-deductive' mode.
- [17] Michaelides PG. "Everyday observations in relation with Natural Sciences". Learning in Mathematics and Science and Educational Technology; University of Cyprus July 2001; Volume II, p. 281–300. <http://www.clab.edc.uoc.gr/pgm/71.pdf>
- [18] Michaelides PG, Miltiadis T. Science Teaching with Self-made Apparatus. 1<sup>st</sup> International Conference on Hands on Science: Teaching and Learning Science in the XXI Century; 2004 Jul 5-9; Ljubljana, Slovenia. Ljubljana: University of Ljubljana; 2004. <http://www.hsci.info/hsci2004/index.html>
- [19] See **a/** Papert S. Mindstorms, Children, Computers and Powerful Ideas. Basic books. New York; 1980 and **b/** Papert S, Harel I. Constructionism. Ablex Publishing Corp.; 1991.
- [20] Anagnostakis S, Michaelides PG. Results from an undergraduate test teaching course on Robotics to Primary Education Teacher – Students. Proceedings of the International Conference on Hands on Science; 2007 July 23-27; Universidade dos Azores; p. 3-9.
- [21] Physlets are applets (computer applications) specific to present S&T issues, usually emulations of natural phenomena, see more in the web or in Belloni C, Belloni M. Physlet Physics. Pearson Education Inc.; 2004.
- [22] See for example Kuhn T. 'The Structure of Scientific Revolutions. Chicago: University of Chicago Press; 1970. In his works, Kuhn claims that scientific progress is not only linear by the accumulation of new knowledge ('normal science' equivalent more or less with the early 'scientific method') but also through periodic revolutionary gaps invalidating previous explanations of observations ('Kuhn-loss').
- [23] See **a/** Against Method: Outline of an Anarchistic Theory of Knowledge (1975), ISBN 0-391-00381-X in which he creatively refutes the notion of any single authoritarian scientific method advocating 'theoretical anarchism' or **b/** The Tyranny of Science (2011), ISBN 0-7456-5189-5 in which he constructively criticizes the context of (absolute) positivism in Science and the consequent widespread perceptions of 'the scientific truth'.
- [24] See for example **a/** Lakatos I. Criticism and the Growth of Knowledge. Musgrave ed.: Cambridge University Press; 1970. **b/** Lakatos. Proofs and Refutations. Cambridge University Press; 1976. **c/** Lakatos. The Methodology of Scientific Research Programmes. Philosophical Papers Volume 1, Cambridge University Press.; 1978. Lakatos works manage to reconcile the views of Popper and Kuhn.
- [25] 'Rationalism vs. Humanism' may seem to imitate the fruitful and continuing philosophical bi-polarity of *Nouç* (Mind) vs., *Υλη* (Matter), Determinism vs. Indeterminism, Materialism vs. Humanism. However, in those bi-polarities, starting from different viewpoints a detailed search for the issue under study was made, advancing human cognition. In contrast, 'Rationalism vs. Humanism' seems to invent arguments to not search the issue under study as irrelevant to the argumentation and resides on beliefs. See: <http://www.dharma-haven.org/science/myth-of-scientific-method.htm>.
- [26] Sokal AD. Transgressing the boundaries: toward a transformative hermeneutics of quantum gravity. Soc. Text 14; 1996; p. 217–252. Sokal wrote later "I intentionally wrote the article so that any competent physicist or mathematician (or undergraduate physics or math major) would realize that it is a spoof. Evidently the editors of Social Text felt comfortable publishing an article on quantum physics without bothering to consult anyone knowledgeable in the subject" (Sokal AD. "A Physicist Experiments with Cultural

Studies," *Lingua Franca* May-June; 62-64. 1996)

- [27] The clear demarcation of Science from pseudoscience is vital for the existence of a rationalistic society. An introduction for non-specialists may be found in <http://www.lse.ac.uk/philosophy/department-history/science-and-pseudoscience-overview-and-transcript/>.
- [28] Powell MA. *Academic Tutoring and Mentoring: A Literature Review*. California Research Bureau: California State Library; 1997.  
<http://www.library.ca.gov/crb/97/11/97011.pdf>.
- [29] a/ Tytler R. A comparison of year 1 and year 6 students' conceptions of evaporation and condensation: dimensions of conceptual progression. *International Journal of Science Education*, 22:5, 447-467, DOI: 10.1080/095006900289723. 2000  
b/ Tytler R, Peterson S. Deconstructing learning in science—Young children's responses to a classroom sequence on evaporation, *Research in Science Education*, 30, 339–355; 2000.
- [30] de Bono E. *Lateral Thinking - A Textbook of Creativity*. Penguin Books; 1990.
- [31] Leon M, Lederman DT. *The God Particle: If the Universe Is the Answer, What Is the Question?* (ISBN 0-385-31211-3). The Legend is that Lederman, one of the 1988 Nobel Prize Laureate for Physics, prepared a review book on 'The Goddamn Particle' in order to stress the unsuccessful attempts to spot the Higgs boson but his publisher convinced him to change to 'God particle' as a politically correct and a better selling title. The publicity on the discovery of the 'God particle' busted folkloric superstition about 'CERN scientists proving God's existence'.
- [32] Vlachos GD. Investigate the views of Greek and German Primary and Secondary School students on Heat and the effect of teaching towards their modification, Rethimno 2001, PhD Thesis, Department for Primary Education Teachers, The University of Crete (in Greek). In this work the ideas on heat of primary and secondary school students in Germany and in Greece were studied. It was found that Greek students in Greece, German students in Germany, Greek and other immigrant students in Germany all enter schooling sharing same ideas on Heat within the model of 'caloric fluid' (despite their different socio-economic backgrounds) and that these ideas were persistent and difficult to change.
- [33] Weiss L. EII and Non-EII Students' Misconceptions about Heat and Temperature in Middle School. M Ed. Thesis, Dept. of Teaching and Learning Principals in the College of Education at the University of Central Florida; 2000. [http://etd.fcla.edu/CF/CFE0003238/Weiss\\_Leah\\_C\\_20108\\_MEd.pdf](http://etd.fcla.edu/CF/CFE0003238/Weiss_Leah_C_20108_MEd.pdf)
- [34] Pathare SR, Pradhan HC. Students' misconceptions about heat transfer mechanisms and elementary kinetic theory, *Physics Education* 45(6), p. 629-634.
- [35] Xirouhaki F. Alternate conceptions of students about Science – common characteristics. M. Ed. Thesis. Rethimno: Dept. for Primary Education Teachers. University of Crete (in Greek) 2010.
- [36] Tsigris M, Michaelides PG. On the Feasibility to Include Contemporary Science Concepts in the Primary School Curricula: A Retrospection into Two Case Studies. Proc. of 3<sup>rd</sup> Int. Conference on Hands-on Science: Science Education and Sustainable Development; 2006 Sep 4-9; Braga, Portugal. Braga: Universidade do Minho; 2006. p. 261-266.
- [37] MacDonald T, Bean A. Adventures in the subatomic universe: An exploratory study of a scientist–museum physics education project. *Public Understand, Sci.* 20(6) (2011) 846–862, Sage Publications.
- [38] Moll LC (Ed.). *Vygotsky and Education: Instructional Implications and Applications of Sociohistorical Psychology*. NY: Cambridge University Press; 1990.
- [39] Yin Cheong Cheng et all (editors). *New Teacher Education for the Future – International Perspectives*. Kluwer Academic Publishers.
- [40] Abel SK (Editor). *Science Teacher*



Education – An International Perspective.  
Kluwer Academic Publishers.

- [41] Costa M, Costa I et al (editors). Student Teaching Practice in Europe. Fillibach-Verl, Freiburg im Breisgau. 2001.
- [42] Prensky M. Digital Natives, Digital Immigrants, On the Horizon. MCB University Press; Vol. 9 No. 5 Sep- Oct 2001.
- [43] See for example a/ Halkia K. 'Difficulties in Transforming the Knowledge of Science into School Knowledge', in Valanides, N. (ed.): Science and Technology Education: Preparing Future Citizens. 1<sup>st</sup> IOSTE Symposium in Southern Europe, Paralimni (Cyprus), University of Cyprus, 2001, Vol. 2 p. 76-82 and b/ Halkia Kr. Greek teachers' attitudes towards the teaching of the subject of physics in primary and secondary education. Contemporary Education; Vol. 106, p. 47-56.
- [44] Michaelides PG. An affordable and efficient in-service training scheme for the Science Teacher. Proceedings on Sixth International Conference on Computer Based Learning in Science. 2003 Jul 10. Cyprus, Nicosia. Cyprus: University of Cyprus; 2003. p. 900-910.
- [45] <http://www.clab.edc.uoc.gr/aestit/>.
- [46] Piaget J. To Understand is to Invent: The Future of Education. New York: Grossman Publishers. p. 14. 1974.
- [47] Gilbert JK, Boulter CJ, editors. Developing Models in Science Education. KLUWER Academic Publishers; 2000.
- [48] I use the following working definitions: 'Laboratory' refers to practice work aiming *mainly* to the development of cognitive skills (e.g. knowledge, intellectual skills, etc.) and is mostly encountered in general and in professional education. 'Workshop' *focus* to the development of dexterities (e.g. the use of equipment in an appropriate and efficient way, the preparation of technical reports, etc) and is mostly encountered in technical-vocational and in professional education. These two aims are not mutually exclusive but they overlap to an extent depending on the specific curriculum. Technical – vocational education refers to the development of skills and dexterities applying knowledge and techniques to the construction, maintenance, of goods or to the running of services. 'Professional' education refers to the detailed study of an area of sciences and knowledge, it may also include a minor or stronger technical – vocational component, the higher education is an example.
- [49] Michaelides PG. "Polymorphic Practice in Science", proceedings of the 1<sup>st</sup> Pan-Hellenic Conference on the Didactics of Science and the introduction of New Technologies in Education. 1998 May 29-31. Thessaloniki, Greek. Thessaloniki: University of Thessaloniki; 1998. p. 399-405.
- [50] Traditional tutoring aims to the objectives of the teaching referring to cognition while mentor type teaching, without neglecting these objectives, aims on guiding the student to feel confident and become able to solve his/her problems in general – see [28].
- [51] Fradd SH, Lee O. Teachers' Roles in Promoting Science Inquiry With Students From Diverse Language Backgrounds. Educational Researcher. 1999 Aug-Sep. p. 14-20. <http://edr.sagepub.com>
- [52] Lee O, Fradd SH. 'Science Knowledge and Cognitive Strategy Use among Culturally and Linguistically Diverse Students'. Journal of Research in Science Teaching, Vol. 32, no. 8, p. 797-816. 1995.
- [53] A Google search with keywords 'Science Education' or 'Science Teaching' returned 469 Million and 81 million hits respectively in about 0.3sec. Even for the less spoken Greek language the corresponding hits are 179 and 18 thousands. Although there are large overlaps and repetitions these numbers are indicative of the relevant activities.
- 
-

## Design for a Visit to an Informal Learning Activity at the University

*X Prado<sup>1</sup>, S Lorenzo-Álvarez<sup>1</sup>,  
XR Sánchez<sup>1</sup>, BV Dorrío<sup>2</sup>*  
*<sup>1</sup>IES Pedra da Auga, Ponteareas,  
Pontevedra, Spain*  
*<sup>2</sup>University of Vigo, Spain*  
*yogote@edu.xunta.es,  
xoseramonsanchez@edu.xunta.es,  
sonialorenzoalvarez@edu.xunta.es,  
bvazquez@uvigo.es*

**Abstract.** Given that a small number of pre-university students were to participate in the Science Week at the University of Vigo, a series of activities was designed in order to make the most of the informal learning experience, both in terms of knowledge construction and skills acquisition. Despite there not being a significant number of participants, the methodology and analysis employed could be useful as a reference for similar activities.

**Keywords.** Energy, environment, informal learning, materials, problem based learning, university.

### 1. Introduction

It is the job of all educational agents and researchers to use the necessary tools so that the public can perceive Science and Technology as the source of their wellbeing, wealth, progress, and prestige both at home and abroad. [1]

Visits to interactive museums can partly fulfil that mission and be a complement to science learning undertaken at school. So that the museum can be a genuine learning tool during school visits, strategies and approaches are needed that are based on the students' learning more than on the hands-on modules themselves. In general, teachers set very limited or generic aims for a museum visit, mainly to connect science to society and to have a fun science class [2]; there is often little accompanying or follow-up material in the museum, which works against the positive expectations from successful work done beforehand [3,4]; and a constructivist interaction between the learners and the teacher, who acts as a learning facilitator, is fundamental in this context [5-9].

Since 2007, The Higher School of Mining Engineering (HSME) at the University of Vigo has held a science dissemination activity as part of its Science Week. It is aimed at pre-university students and is based on the provision of practical workshops for them to attend in the form of small, informal, fun learning areas that attempt to clone or replicate the conventional model of an interactive or science museum in the Mining School's research and teaching facilities [10].

This space allows the community around the centre to approach its research and to receive its results and is run by the HSME's teachers, research staff and students in their final two years of study. The atmosphere is one of explanation-attention by peers or equals in a collective and cooperative activity in which the students are co-responsible for its definition, assembly and monitoring.

The monitor-guide students are trained before the event by teaching and research staff, who also carry out coordination and organisation tasks to set the guidelines for the contents, the corporate image for the audio-visual presentations, and the protocols for how the material is to be presented and interpreted (Figure 1).

By allowing the public to have direct contact with research material that has been interpreted and adapted for dissemination, this activity seeks to take university life to the people and foster a vocation for science and technology among the young while at the same time introducing the real world of the laboratory to the public (Figure 2). This includes, for example, those related to (Figure 3): an active demonstration to simulate explosives handling; active demonstrations of field work using 3D laser contour scans; image taking using a thermal camera; hands-on activities to show the possibilities of sustainable energies in general, and biomass in particular; and activities that clearly show the characteristics and properties of new materials such as ceramics, metals or hybrids.

During the 2014-15 academic year, the teachers at the Pedra da Auga Secondary School proposed centring their work on small groups using as a basis the modules provided during Science Week, in an attempt to make the most of their visit to HSME by completing the information on offer there with preparation

work on the five modules included in the visit.



**Figure 1. Guides, interpreters, intermediaries, monitors, presenters and mediators**

Activities were proposed for before, during and after the visit. The core idea was to try to link the contents of the modules with the topics for Physics and Chemistry in the 4th year of compulsory secondary education in such a way that the visit could be used as a teaching element integrated into the classroom curriculum. Learners were also encouraged to use information and communication technologies (ICTs) by setting up and keeping team blogs, gathering information from online and presenting results in an electronic format (PowerPoint and Prezi). All the blogs were made available on a webpage created especially for the occasion under the generic name “megascience” [11]. A lab activity was also included for each group, which meant the experience could be turned into an emulation of real scientific work. The proposal also involved public exhibition of the results and conclusions before a panel made up of teachers from both centres and learners from other years.

This work presents the experience before, during and after participation at the 2014 Science Week and shows the learning outcomes achieved after the prior preparation, the tasks during the activity and the actions taken later back at the school. It presents the results of our own evaluation, by peers and for satisfaction.

## **2. Coordination and collaboration in Science Week participation**

In order to make significant use of an

informal out-of-school visit, not only conceptually but also emotionally and socially in terms of the contents of the formal curriculum, tasks of relating, guiding and contextualising are required [12]. It is necessary, as far as possible, to link the itinerary at the visited centre to the curriculum of the students involved by designing a series of activities that will make the most of the resources available [13] and involve work both before, during and after the visit [14].

The idea is to arouse the students’ interest in Science without forgetting to raise questions that attempt to explain a particular reality, and thus not leaving to one side the open and changing nature of Science as a whole [14-16].



**Figure 2. Public participation at the 2014 event**

Pupils were also asked to take part in role-model activities or to design and construct technological elements or carry out scientific workshops that involved solving or overcoming a problem or challenge. This way of learning, with fully active students, develops important competences: basic features of scientific work (such as team-working skills, organisation and methodology, analytical and communication skills and initiative), the use of ICTs, interpretation and use of data and information, Science-Technology-Society (STS) relationships or the practical and safe use of lab material [17]. This is what really sticks in their minds and they will be able to re-use the learning and, of course, improve upon it with new material from later courses that complements the material used here.



Figure 3. Some examples of workshops from the 2014 event

### 3. Structured activity proposal

Five groups of three pupils were formed and each one selected a module from those on offer at the HSME Science Week as the objective of their scientific research and activity. Each group defined the questions to ask during the visit on the basis of a review of material provided by the teacher or obtained from the Internet. During the visit the groups were structured as small press groups: interviewer, secretary and photographer (Figure 4). Their work was rounded off with experimental tasks and the creation of a blog for each group in a shared space which took advantage of the programme contents and provided extra information for students to use in their work both in the classroom and at home [18-22].

An attempt was made to link the different module contents to the 4th year curriculum studied by the groups. Some were common elements such as the importance of scientific research (recognising that the scientific process is a team effort to create and disseminate knowledge, and carrying out team-based tasks for scientific research) and the importance of Information and Communication Technologies (ICTs) in scientific work (using them to draw up and defend a research project). Others were specific to the different modules.

An initial test of prior knowledge was undertaken, which confirmed that the participating students, except for basic notions

about the contents studied in previous years such as light and atoms, did not have a clear idea of the subjects in the teaching proposal. During the visit, each group took part in the presentation of all the modules, and after each one the members of the specific team assigned that module approached the monitor to ask the questions they had prepared. The aim was to glean information from the monitor's answers.

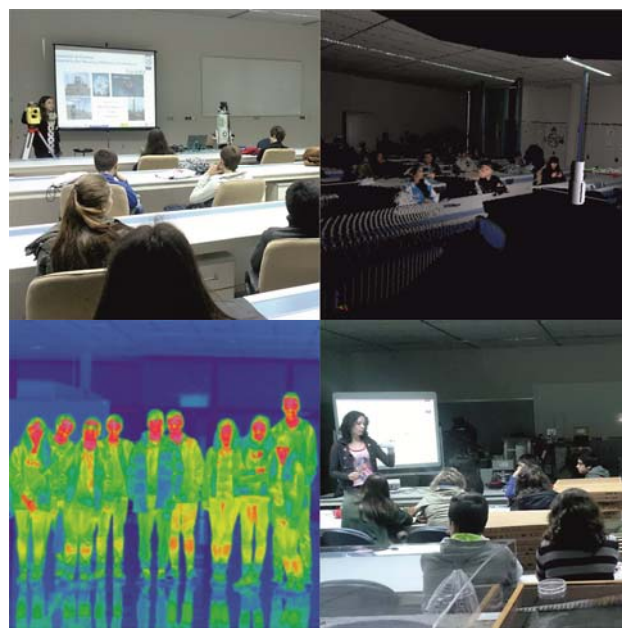

Figure 4. Visit by students from IES Pedra da Aula Secondary School to the 2014 Science Week

An initial test of prior knowledge was undertaken, which confirmed that the participating students, except for basic notions about the contents studied in previous years such as light and atoms, did not have a clear idea of the subjects in the teaching proposal. During the visit, each group took part in the presentation of all the modules, and after each one the members of the specific team assigned that module approached the monitor to ask the questions they had prepared. The aim was to glean information from the monitor's answers.

Subsequent experimental work on the modules in the pre-university centre added value to what had been learnt during the participation in Science Week (Figure 5). Thus, for the renewable energies module [18], dry distillation of wood was undertaken to obtain acetylene gas.

For the explosives technologies module [19] an experiment was carried out to obtain hydrogen and then water through the explosive



reaction with atmospheric oxygen (implosion).

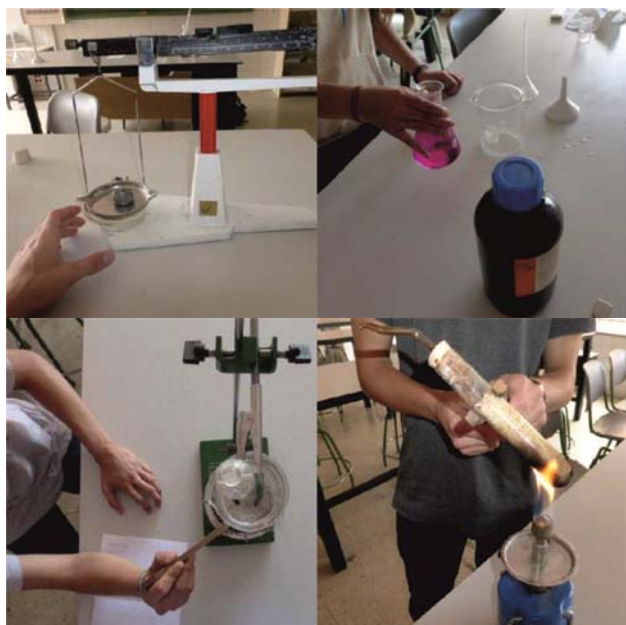

**Figure 5. Complementary experimental activities in the school lab**

For the module dealing with 3D laser and geo-radar surveying [20], a project to construct a pinhole camera obscura (simple and double) was proposed to use the basic knowledge of light phenomena that had been studied in previous years.

For the energy efficiency module [21] a project was designed around water heating to show the difference between the heat used to change the state of the material and the heat used in the heating-cooling.

The group involved in the new materials module [22] carried out studies on the different properties of materials such as their density or hardness.

Each group made a public presentation, which included a brief description of their blog (Figure 6).

#### **4. Results and evaluation**

Since 2007, centres taking part in the HSME Science Week have been given an activity evaluation survey to fill out and send back after the event [23]. The survey results provide interesting information concerning the effect of the visit with regards student attitudes to Science and scientific knowledge. In 2014, 95% of all the surveys handed out were received back. In general, the impact of the activities on visitors was in the main considerable or

outstanding. The perception of the pupils from the Pedra da Auga secondary school with regards the degree of suitability, knowledge, learning and satisfaction did not differ much from the general averages for the activities. This was also true in terms of the attention received, the materials used or the organisation. The general assessment of the activity (7.4) is very close to the overall average obtained for all eight years (7.7).

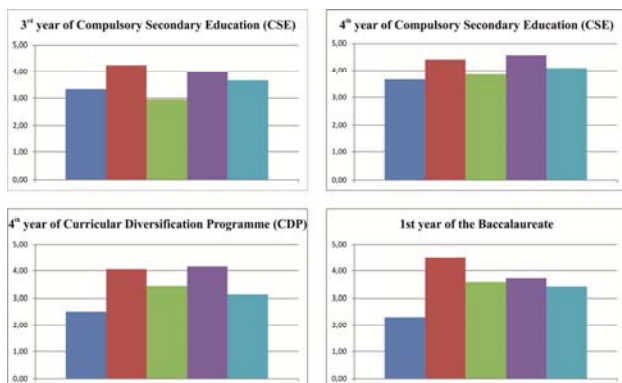

**Figure 6. Presentation session of the assignments**

The result of the process, which was enriching and motivating, was highly positive, showing students' individual mastery of language and new audiovisual IT technologies. This estimation, gathered by teachers from the Pedra da Auga secondary school, also agrees with that given in the surveys, which were carried out using a simple rubric for the 60 or so pupils from the 3rd and 4th years of Compulsory Secondary Education (CSE), 4th year of the Curricular Diversification Programme (CDP) and 1st year of the Baccalaureate who had attended the presentations (Figure 7).

During the third evaluation a test of final knowledge was set. This was to check the educational effect of the activities with regards the subject matters for Physics and Chemistry. The results obtained contrasted with those from the knowledge test taken prior to the activities. They are given in Table 1. In order to quantify the persistence of prior knowledge, the learning gains coefficient  $g$  was used [24]:

$$g = \frac{\%post\ test - \%pre\ test}{100\% - \%pre\ test}$$

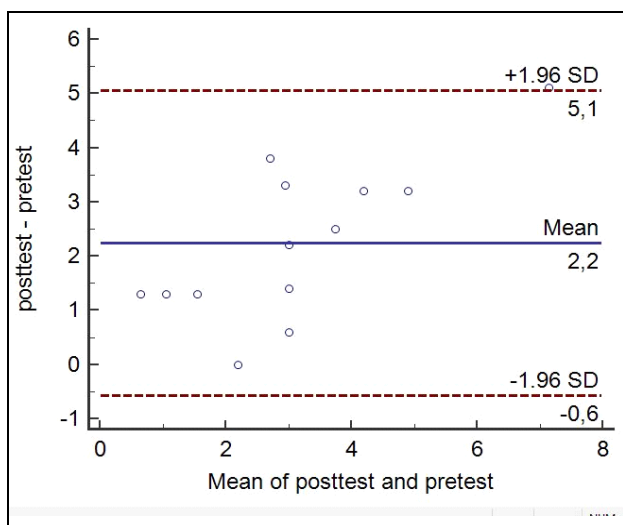

**Figure 7.** From left to right: biodiesel (WEB 4), explosives (WEB 5), 3D camera (WEB 6), thermal imaging (WEB 7) and new materials (WEB 8). Assessment criteria: 1 incomplete contents; 2 improvable contents; 3 correct contents; 4 relevant contents; 5 very relevant contents

This relates the percentage of correct answers before and after and assumes a high gain for values over 0.7, an average gain if the value is between 0.3 and 0.7, and a low gain for values under 0.3.

Pupils	B1	B2	B3	E1	E2	E3	C1	C2	T1	T2	T3	N1	N2	N3
Pre-test	0	0.8	2.7	2.6	1.3	0.4	2.2	4.6	3.3	2.5	0.9	1.9	2	2.3
Post-test	1.3	4.6	3.3	5.8	4.6	1.7	2.2	9.7	6.5	5	2.2	4.1	-	3.7

**Table 1.** Results for pupils in pre-and post-tests for knowledge by group for the activities: Biodiesel, Explosives, 3D Camera, Thermal imaging, New materials



**Figure 8.** Bland-Altman analysis of Table 1

The overall gain coefficient has a value of  $g=0.3$ , on the threshold between low and average scores. Agreement between the tests

was carried out by using the graphical analysis given in the study by Bland-Altman, using the MedCalc program in this case [25]. This test compares two tests carried out and visibly plots the dispersion and relation of the data and the differences between both of them compared to the mean.

The graph (Figure 8) indicates acceptable improvement between both tests inasmuch as the difference between them was 2.2. The limits for agreement, with confidence level 95%, are defined by this mean value plus/minus 1.96 times the standard deviation of the differences, 1.47, which means that most of the pupils are close to the mean.

## 5. Conclusions

In order to create the conditions for efficient knowledge construction during participation in an informal learning activity, the activity should to be integrated within the syllabus for that year's study and the pupils should develop their autonomy within their own possibilities, being encouraged to carry out their own research from the information they have about the questions asked in the classroom before visiting the activity, and based on the hypotheses that were formulated [26]. That is, later participation begins with preparation beforehand in the classroom. Afterwards, the teachers take the discussions arising before and during the visit and raise questions in order to redistribute the work done by the groups, guiding the sharing, reformulating the various contributions and indicating the result obtained by the scientific community. If it is not done in this way, and there are no clearly programmed objectives, or no strategies that allow the pupils to gather information on the basis of a previously discussed challenge, then the objectives being sought may not be achieved.

This work presents an intervention proposal based on the participation of a small group of pupils from the Pedra da Auga secondary school in the Science Week organised by the HSME of the University of Vigo related to energy, new materials and the environment. A series of activities (for data gathering, handling experiments, presentation, etc.) were designed with collaboration among the teaching staff of both centres in order to develop competences beyond knowledge acquisition, such as interaction with the physical world, learning to learn, personal autonomy and initiative, and

handling new information and communication technologies (ICTs). In terms of knowledge construction from these informal activities, it can be seen from the pre- and post-tests that learning was better when the pupils showed a high level of participation. For example, the groups for Explosives and Thermal Imaging, who scored highest for the presentation of their work, also showed a greater degree of gain between the two tests.

In this sense, the overall results show a positive impact on participants, not only in the degree of self-esteem perceived during the process but also in the satisfaction derived from presenting all their work to the rest of the educational community. Blog creation, in addition to developing ICT skills, allowed the other pupils, teachers and families to see the results of the activity (scientific experimentation, design and construction of technological devices, the motivation shown in the project, etc.) which added value to the work done and avoided the possibility of there being a passive attitude.

Despite the sample size of participating pupils not being significant, it can be understood that the protocol followed could be used in other informal learning situations at pre-university level, where success of the proposal depends on the work done before, during and after the activity.

## 6. Acknowledgements

The authors are grateful to all the participating teachers, students and support staff at HSME and the Pedra da Auga secondary school for their help.

## 7. References

- [1] FECYT. *Cómo estimular mentes científicas*. Barcelona: Obra Social A Caixa; 2015.
- [2] Griffin J, Symington D. Moving from task-oriented to learning-oriented strategies on school excursions to museums. *Science Education* 1997; 81(6) 763-79.
- [3] Gennaro ED. The effectiveness of using previsit instructional materials on learning for a museum field trip experience. *Journal of Research in Science Teaching* 1981; 18(3), 275-79.
- [4] Falk JH, Dierking LD. *The museum experience*. Washington, DC: Whalesback; 1992.
- [5] Resnick LB. Mathematics and Science Learning: a new conception. *Science* 1983; 220, 477-87.
- [6] Guisasola J, De la Iglesia R. 'Erein projektua': proyecto de ciencias para la ESO basado en la resolución de situaciones problemáticas. *Alambique* 1987; 13, 83-93.
- [7] Driver R. Students' conceptions and the learning of Science. *International Journal of Science Education* 1989; 11, 481-90.
- [8] Hofstein A., Rosenfeld S. Bridging the gap between formal and informal science learning. *Studies in Science Education* 1996; 28, 87-112.
- [9] Gil D, Vilches A, González E. Otro mundo es posible: de la emergencia planetaria a la sociedad sostenible. Una propuesta de museo de ciencias que ayude a la reflexión sobre la situación del mundo. *Didáctica de las Ciencias Experimentales y Sociales* 2002; 16, 57-81.
- [10] <http://etseminas.webs.uvigo.es/> [visited 20-Jun-2015]
- [11] <https://sites.google.com/site/quimicaiespda/> [visited 20-Jun-2015]
- [12] Guisasola J, Azcona R, Etxaniz M, Mujika E, Morentin M. Diseño de estrategias centradas en el aprendizaje para las visitas escolares a los museos de ciencias. *Revista Eureka sobre enseñanza y divulgación de las Ciencias* 2005; 2 (1). 19-32.
- [13] Campillo Y, Chamizo JA. Los museos: un instrumento para el aprendizaje basado en problemas (ABP). *Revista Eureka sobre enseñanza y divulgación de las ciencias* 2011; 8 (3), 312-22.
- [14] Aguirre C, Vázquez AM. Consideraciones generales sobre la alfabetización científica en los museos de la ciencia como espacios educativos no formales. *Revista electrónica de Enseñanza de las ciencias* 2004; 3 (3), 339-62.

- [15] Dorrío BV. Museos interactivos na escola. Revista Galega de Educación 2006; 35, 20-22.
- [16] Guisasola J, Morentin M. Concepciones del profesorado sobre visitas escolares a museos de ciencias. Enseñanza de las ciencias 2010; 28 (1). 127-140.
- [17] Pedrinaci E. El desarrollo de la competencia científica. Barcelona: Graó; 2010.
- [18] <http://bioideasaqui.blogspot.com/> [visited 20-Jun-2015]
- [19] <http://hugopatriciaadrian.blogspot.com.es/> [visited 20-Jun-2015]
- [20] <http://iriayalex.blogspot.com.es/> [visited 20-Jun-2015]
- [21] <http://camaratermica.blogspot.com/> [visited 20-Jun-2015]
- [22] <http://losjosplasticos.blogspot.com/> [visited 20-Jun-2015]
- [23] Dorrío BV. Actividades manipulativas colectivizadas: investigación interpretada na E.T.S.E. de Minas. Prácticas educativas innovadoras na universidade. Vigo: Tórculo Artes Gráficas 2008; 51-65.
- [24] Hake RR. Interactive-engagement versus traditional methods: A six-thousand-student survey of mechanics test data for introductory physics courses. American Journal of Physics 1988; 66(1), 64-74.
- [25] <https://www.medcalc.org/> [visited 20-Jun-2015]
- [26] Azcona R, Etxaniz M, Guisasola J, Mujika E. Chispas de Energía, manual del profesor. San Sebastián: Miramón Kutxaespacio de la Ciencia; 2002.
- 
-



## Hands-on Experiments in the Formation of Science Concepts in Pre-school

J Trna

Masaryk University, Czech Republic  
trna@ped.muni.cz

**Abstract.** The study presents the design-based research results of the development of educational methods and tools containing hands-on experiments in playing and games appropriate for the formation of science concepts in pre-school. Specific examples of these hands-on experiments are presented. The formation of science concepts begins from birth. Children have cognitive needs which motivate them to actively get to know the world. Some basic science concepts (shape, size, volume, time, colour etc.) are formed at pre-school age in non-formal education as preconceptions, which strongly affect continuous science education. Therefore the formation of science concepts is an important educational objective for pre-school education in families and kindergartens. Hands-on experiments implemented into playing and games have an important role in the formation of science concepts.

**Keywords.** Concept, formation, hands-on experiments, pre-school, science education.

### 1. Introduction

Cognitive needs motivate child to get to know themselves and the world around them actively from birth [2]. The core approach of forming the first science concepts is inquiry through all a child's senses. Children perform simple observations and experimentation with objects in their surroundings and with their own bodies. In this exploration children discover the characteristics of objects such as shape, size, colour, temperature etc. This is the origin of children's first notions of the world, known as preconceptions. These preconceptions and in particular misconceptions significantly affect the formation of scientific concepts in future science education. When forming scientific concepts, observation and experimentation play an essential role. A specific role is played by hands-on experiments [3]. Hands-on experiments should be set in children's playing and games, especially for motivation. The study focuses on the role of hands-on experiments in

the form of toys in the formation of scientific concepts in pre-school formal and informal science education.

### 2. Rationale

Playing and games are natural children's activities that are necessary for complex personality development. Playing and games can be defined as free activities which bring the satisfaction of needs, enjoyment, entertainment and also some knowledge and experience for players. These activities are enjoyed by children very much and create the basis of life [5]. Hands-on experiments are a natural basis for playing and games. *The characteristics of objects*, such as shape and size, are the concepts which result from children's initial observing and experimenting. After that the notions of space begin to form, thanks to the mutual position of objects. Using the research methods of observation of children's activities and structured interviews with children's parents and teachers at kindergartens (in 2011-2014), children's formation of other characteristics of objects (colour, temperature, elasticity, hardness, etc.) were discovered. The child also acquires the basic knowledge of the *characteristics of substances*. The formation of a child's awareness of substances is also based on hands-on experiments into playing and games. Preschool-aged children continue to form science concepts with regard to *natural phenomena*.

### 3. Research question and methods

The role of hands-on experiments in the formation of concepts in pre-school science education was the objective of our research with the research question:

*Which hands-on experiments can support the formation of concepts in pre-school science education?*

Design-based research [4] as a development research method was used. This research can be described as a cycle: analysis of a practical problem, development of solutions, evaluation and testing of solutions in practice, and reflection and production of new design principles. As part of this research, research methods such as comparative analysis of toys, observation of children's activities, interviews and action research etc. were used.

## 4. Research results

A set of educational methods using hands-on experiments in playing and games were discovered and developed. The children observe objects and perform hands-on experiments into playing and games. These appropriate hands-on experiments in playing and games can support the formation of science concepts [1]. Design-based research has resulted in a series of interesting findings. These outcomes are divided into several parts.

### 4.1. Flat shape of objects

The children form their preconceptions by hands-on experimenting with objects of different shapes and sizes. A comparative analysis of about 200 toys offered in toy e-shops was applied. Two basic types of toys forming the children's ideas of the shape and size of objects were identified.



Figure 1. Inserting objects into the matrix

The first kind of these toys usually have the form of a flat matrix with various shapes cut in it. The child tries to insert a shaped object into the appropriate matrix hole. To motivate the child more the inserted objects can represent animals, houses, trains, cars etc. (Fig. 1).

The second kind of these toys are objects of different basic planar shapes falling into appropriate holes in the container (Fig. 2).

### 4.2. Size of objects

These toys are made as a set of identically shaped objects differing in size. The children insert the smaller objects into the larger ones step by step (Fig. 3). The motivational effect is

increased by objects shaped as figures, etc. Russian "matryoshka" dolls are a known variant of this toy.



Figure 2. Inserting objects into the container

### 4.3. Colour of objects

The child learns to identify and distinguish the colour of the objects. There is a wide range of toys supporting the formation of the concept of colour. These toys are based on colour differences or uniformity.

The first type of these toys is a set of objects of the same shape and size (blocks etc.), which differ in colour (Fig. 4). The child's task is to identify the individual colours.

The second type of these toys leads to objects of the same colour being grouped (Fig. 5).

### 4.4. Combination of object shape, size and colour

The formation of concepts such as shape, size and colour should be developed through a combination of these. There are a lot of appropriate toys (Fig. 6 and 7).

### 4.5. The characteristics of substances examined by touch and other senses

The child also learns the characteristics of substances such as paper, glass, wood, plastic, metal, ceramic, rubber, etc. These substances have specific characteristics such as plasticity, elasticity, hardness, etc. The concept of substance characteristics can be also formed by hands-on experiments in the form of playing

games. Through observation and hands-on experimentation children classify substance characteristics using a combination of their sensory perceptions. A set of experiments for the concept formation of substance characteristics was developed:



**Figure 3. Set of objects of different sizes**

Firstly, the child touches objects (for example balls – Fig. 8) made of different substances and so becomes familiar with various substances. The child touches the balls, looks at them and performs hands-on experiments (a rubber ball is elastic etc.). Then we put the balls into a bag. The game is based on the task to identify the ball made of a specified substance only by touch by inserting their hands into the bag with the balls. After identifying the substance of the ball, the child takes it out of the bag and verifies the correctness of the choice.



**Figure 4. Objects of different colours**

#### **4.6. Study of natural phenomena**

A higher stage of forming concepts is the

study of natural phenomena through hands-on experiments in playing and games [7]. Some examples of these experiments with balls are presented.

Sinking and floating: We drop a few balls made of different substances into a glass with water (Fig. 9). Some of them sink and some of them float according to their characteristics. This hands-on experiment creates a child's preconception of density.

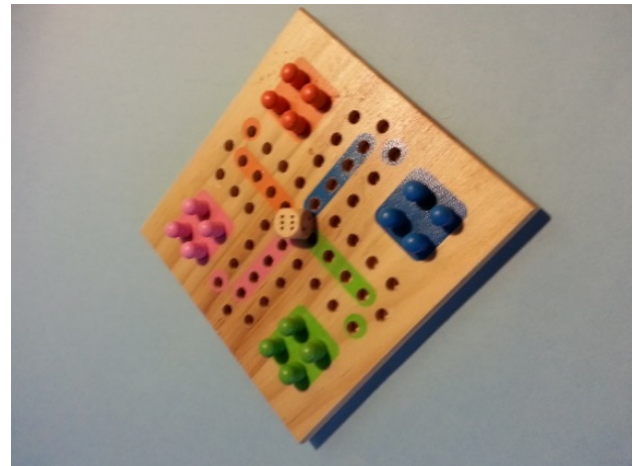

**Figure 5. Grouping of objects with the same colour**



**Figure 6. Colourful objects of different shapes**

Magnetic characteristics of substances: We place a permanent magnet near some balls made of different substances. The magnet only draws the balls made of ferromagnetic substances (Fig. 10). This hands-on experiment creates a child's preconception of



the magnetic characteristics of substances.



**Figure 7. Inserting colourful objects of different shapes into the matrix**



**Figure 8. A set of balls made of different substances**



**Figure 9. Sinking and floating**

## 5. Discussion

The final step in design-based research is reflection and generalization of the results of

this research. It is problematic to test how effective the fostering of the formation of science concepts is. Based on our research results combined with interviews with teachers and parents, as well as the observation of children when playing and during games, we can come to the following conclusion (hypothesis for future research): Hands-on experiments implemented in playing and games in pre-school education can support the creation of correct preconceptions of science concepts in formal (in kindergarten) and also informal education (in the family). The conclusion of our research should be verified in further research and implemented in science teacher education. We plan to carry out a long-term study and case studies that may reveal the effectiveness of support for the formation of basic science concepts with hands-on experiments implemented into playing and games.

## 6. Conclusions and recommendations

A set of types of hands-on experiments with toys that are implemented in playing and games appropriate for the formation of science concepts were identified. These hands-on experiments in playing and games can support the formation of science concepts in pre-school formal (in kindergarten) and informal science education (in the family). It is necessary to implement these hands-on experiment tools into pre-school science education. Our findings are implemented in the preparation of kindergarten teachers in our university [6]. We also try to pass them on to parents through the Internet. Cooperation in designing appropriate toys with toy manufacturers might be important as well.

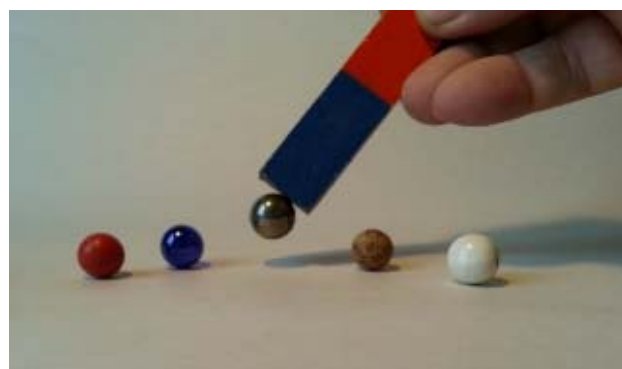

**Figure 10. Magnetic characteristics of substances**

## **7. References**

- [1] Abrahams I, Millar R. Does Practical Work Really Work? A study of the effectiveness of practical work as a teaching and learning method in school science. *International Journal of Science Education* 2008; 30(14): 1945-1969.
  - [2] Garson Y. *Science in Primary School*. London: Routledge; 2002.
  - [3] Haury DL, Rillero P. *Perspectives of Hands-On Science Teaching*. Columbus: ERIC-CSMEE; 1994.
  - [4] Reeves TC. Design research from the technology perspective. In: JV Akker, K Gravemeijer, S McKenney, N Nieveen, editors. *Educational design research*. London: Routledge; 2006. p. 86-109.
  - [5] Singhal A, Cody MJ, Rogers EM, Sabino M. *Entertainment-Education and Social Change: History, Research, and Practice*. Lawrence Erlbaum Associates; 2003.
  - [6] Trnova E. IBSE and Creativity Development. *Science Education International* 2014; 25(1): 8-18.
  - [7] Trnova E, Krejci J. Hands-on Experiments in the Formation of Science Concepts in Primary Education. In: M Costa, P Pombo, BV Dorrio (Eds) 11th International Conference on Hands-on Science. *Science Communication with and for Society*. Braga: The Hands-on Science Network; 2014. p.109-11.
- 
-

## Child's Play or a Child's Crucial Work? The Importance of Play in the Learning of Science

*S Dale-Tunncliffe*  
*Reader in Science Education*  
*UCL Institute of Education*

**Abstract.** Is playing a waste of time? Or is it an essential apprenticeship in developing scientific literacy? Children are often observed during play, which is divisible into experimental investigative play when they explore phenomena and narratives, when they are working through a past experience imaginatively or interpreting a story they have heard. (Play is the work of children and essential for intellectual achievement and emotional wellbeing (Whitbread et al., 2012).

Children are spontaneous investigators, curiosity is innate. They explore using themselves. Hence hands on activities are the feature of children's play and such are essential in the learning of science in the early years. They observe, learn what actions produce what effect or what action or object or organisms they have observed does what, the essence of science. The science explanation is not needed in this key initial learning phase where they observe, question, design an investigation, observe what happens and note the outcome. These experiential learners do not need an explanation, they need to add the experience to their learning repertoire, to be retrieved at a later date Such practical experience of the phenomenon inessential to further learning. At this age the foundations for observational and planning skills are laid as well as the process skills of manipulating items, collecting and evaluating such. Later in a child's formal science education such fundamental experiences provide them with an experiential foundation on which to construct the curriculum science required for examinations.

### 1. Introduction

"Science, during early childhood, Is more than play? It is serious business.

If we fail our children and students in science, the reasons may include lack of appropriate experiences during early childhood"

(Roth et al., 2013.p.14)

Do young children learn science? They play a lot. What is play within terms of developing science literacy in young learners? The role of play which, to me, seems to be a child's 'work' in experiential science in many cases of role play and other imaginative play. I consider science experiences, which are very much part of many play episodes with toys, everyday items and the outdoors explorations are fundamental in developing scientific understanding. Are such activities 'Educational play' or freely chosen play as some researchers consider to be the two aspects of play (Wood, 2015 in Robson, 2015)? Piaget suggested that children are naturally curious and learn from exploring their own environment (Robins, 2012). Children play. In terms of science learning is playing a waste of time? Should adults noticing play intervene when the child's solution to a problem is, on the experience of the adult, not going to 'work', to produce the accepted science observations and outcome? If the child's idea (Hypothesis) is not going to produce the desired outcome? Should the adult point this out or let then child discover that the action he has initiated fails to solve a problem is unlikely to do so? Children develop critical thinking skills Robson, 2014).



Whilst it is sometimes frustrating to watch such happen, it is imperative to building the child's experience (or science repertoire) to let the event proceed.

Daniel when two years old sat on a swing in the children's play are in the par., He thought it would then start swinging and could not



understand why it did not do so. He squirmed around on the seat and then noticed that there was a little movement of the swing, slightly forwards and then back. Eventually he worked out by trial and error he had to input the energy to get the swing to move, and that putting his legs and torso forwards gave results! Which he did to his great pleasure and satisfaction?

His adult could easily have just told him what to do or just pushed him!

## 2. Partnerships

A child's early and so important learning experiences in science are either solitary or in a partnership. Sometime it is a vicarious or modeling partnership in the sense that the child notices, observes, another child or other doing something, like working up the motion of swing, and copies them, as visitors often do in museums for example. Most often a partnership activity is between adult and an early learner, but with a difference. The objective is to use a particular approach advocated of posing a challenge via a cue question to the child. This is not only to provide a stimulus for them to explore a own designed science experience but scaffold the thinking of a participating child through further questions and often with the outcome in the initial question. Such a question as, "Is the moon always visible at night?", whereby the child has to plan a strategy to answer the question. Children have to learn certain skills first of all and then hone them with practice and learn where it is appropriate to apply these skills, thoughts and actions, to a new situation. The partner can assist them in this learning with the appropriate cue as they master the skill to work out their thought. This is difficult to do but try. Bear in mind the words of the Russian psychologist Vygotsky, "What a child can do with assistance today she will be able to do by herself tomorrow"(1987, p.87)

The activities of early years are a starting point but also often a finishing outcome and the child has to work out how to proceed from the start to the outcome. Taking to the learner as s/he progresses in planning an action the actions to meet the challenge can reveal much about the previous knowledge and experience of the learner and their ability to verbalise their thoughts and skill at problem solving. Using open questions and 'push back' questions (Chin, 2008) as such can prompt the

child further in developing their thinking and reasoning.

The partner adult often needs to set up the items to show the starting point and the end point when they want to create a learning opportunity. The one item, e.g. a small magnet, could be labeled 'magnet' and the child be told it is a magnet and explore what effect it has on things. In the case of some studies, e.g. on weather, photographs of a starting and end point might be used, or of a starting point to stimulate Looking- Talking- Thinking and Doing. Thus the learners are encouraged to work out how they can use the starting point and reach the given outcome. In order to conduct this partnership activity, which is not a full structured because you are encouraging their thinking with asking cue questions as appropriate and introducing appropriate cue questions, which do not tell them what to do. The relevant vocabulary is provided, as well as the skills and experiences they need before they can tackle the given activity.

## 3. Observations- actions in play



The above photograph is of children in Bangladesh investigating but playing with everyday items they have found.

Learning science begins with babies looking around, gradually acquiring manipulative skills they can use for a definite action and then play. Learning is gradual and begins with intuitive ideas but is consolidated by noticing a phenomenon, talking about it, and thinking about them again and investigating where appropriate and sharing with someone else.

Learning does not occur in a linear manner but in a constructive, sometimes referred to as a spiral curriculum context, being developed

increasingly in more depth (Bruner, 1977). The starting point for science is observation, (Sylva et al. 1980). We strive as educators to encourage young children and their associated adults, parents, relatives other carers and teachers, to share the observations and talk about such and increase their own self-esteem and literacy. Moreover, children are intuitive scientists (Gopnik, 2009).

The key to starting science is for the adults to observe the child and provide suitable cues for them to develop their ideas and questions. It is essential to understand their use of words, as their meaning may not be the same as that of their adult. As children acquire early language they begin to label phenomena. This naming is an inherent human need (Bruner, Goodnow and Austin, 1956; Markman, 1989). Additionally, young children ask questions incessantly when given an opportunity.

#### 4. Dialogue

It is important not to tell the children what to do, but scaffold the activity with appropriate questions and actions. Such recognition of the different types of questions that may be used is invaluable and recognizing the very basic idea that the learner is exploring and the further scientific knowledge and understanding such investigation can lead to, but not tell the child. Children's attitudes towards science are extremely important as these can influence their early attainment in the subject and their outlook in adulthood to scientific issues, young learners in the early years of schooling young children are particularly enthusiastic, and enjoy practical experiments and independent investigation but this enthusiasm diminishes (Pell & Jarvis, 2010).

#### 5. Skills acquisition

Before some investigation can really be carried out there are certain skills that a learner needs, such as being able to pick up items, pour water, and such foundation experiences are given so you can ensure that the learner has such skills. In a planned learning situation it is useful to have things to use in investigations available so a list of possibly useful items is included. However, through their own play and facilitated opportunities, young children can explore various skills such as water pouring, measuring which provide skills and processes needed in more complex play and science

investigations.

#### 6. Talking and dialogue

We don't tell them or show them, many of use do find this difficult. We try and suggest through dialogue further action.

*"Children, we now know, need to talk, and to experience a rich diet of spoken language in order to think and learn. Reading, writing and number may be acknowledged as curriculum 'basics' but talk is the true foundation for teaching"*

(Alexander, page 9)

However, when engrossed in activity children do not necessarily talk. Very young children who play do not talk, but they do play and investigate. When being involved in imaginative activities, such as telling the story out loud of what, for instance, their Lego figures or toy cars or dolls are doing, and provide an oral narrative. On other occasions when they are involved in observations and investigations they often do not talk, (Tizard, and Hughes, 1984); sometimes they make an out- loud statement which is really a hidden question. Furthermore, it is now accepted that there is an intimate link between language and thought and thus the cognitive development of a child is affected to a considerable extent by the nature, context and forms of language, which s/he hears and uses (Halliday,1993). Unless instructing in some action that could be dangerous, specific instructions to achieve a plan for an investigation and outcome are not given, rather the emergent scientist will need to think and do the investigation as they see fit.

#### 7. Play is crucial stage in learning science

We now recognise that play is crucial to the development of a child (Moyle,1989) and that society should promote awareness of and work to change the attitudes towards play (Whitbread at al., 2012) who point out that play is the work of children and essential for intellectual achievement and emotional wellbeing. Learning through experience is developed in both spontaneous and directed play and introducing inquiry based science fits well into extended play activities progressing to challenges to solve. Play after all is often very much problem solving (Moyle's, 1989). 'Just



playing', has been used in a derogatory sense by educators, and some parents and other adults, unfamiliar with early years learners. Parents, who recollect education and assume this is how it should be manifest for all as their own, usually secondary stage experience, fail to understand the essential and critical value links a child's learning of play. They are learning skills, processes, problem solving. These are crucial skills for science and everyday. Facts are merely a part of learning, problem solving and other skills are vital.

## **8. Children's understanding- children's science**

It is important for adults to find out children's real ideas about the topic. The recognition of the emergence of inquiry science from a child's earliest years stresses the importance of observing the play of early years children. Observing early years children at play provides insight into their basic early science learning. The stages of inquiry science develop from being directed through guided science to open or authentic science with the learner determining the plan, the action and the interpretation of outcomes, is discussed together with exemplars from observed real situations, suggestions for recording and assessment. I stress the partnership between adults, parents, carers or teachers, and child in the learning process.

It is useful for us to bear in mind and that for the child their ideas are the conceptions those of formal science education 'misconceptions, hence gather idea of a child and their personal interpretation should be regarded as alternative conceptions to the accepted wisdom. However, as educators we are required to assist the learner in their journey to the established science.

## **9. Conclusion**

The starting point for the learning of science and engineering, is at this early age, play. In such activities these early learners are making observations, asking questions and problem solving, asking questions, albeit to themselves, their own strategies for eliciting an answer. Such working out by the child are them using 'hidden questions' to themselves even though in the earliest of years, thoughts are not verbalised. Thus, the only evidence, we, as, observers, have is we can see the actions of

children which are thus an expressed model of their science play/investigation. Moreover, such learning occurs in the immediate environment of the child, in its community, with the people with whom s/he spends their time and begins long before any formal educational interaction.

Starting children on their path in learning science as in other subjects is a community endeavor. These places of potential learning are where they live and the immediate environment outside. In these locations children witness everyday activities such as cooking, cleaning, washing, various activities with materials such as textiles, wood, clay, as well as identifying and being involved with basic life processes such as moving, breathing, eating, excreting and the human activities associated with the life processes and beyond. Children are immersed in their environment, to include natural structures, built, human construct such as their village or adjacent areas, which all contain various amounts of technology, maths and science. Thus can range from a simple cooking vessel being used on an open fire to mobile phones; from natural vegetation to a manicured garden and the everyday non-built areas. Moreover, the natural environment is comprised from physical, geological and biological matter and features of this, such as rocks, plants and watercourses may be observed. Additionally, the culture and particular uses of science and technology by the community with whom the children live are evident and noticed, pointed out by members of the community, buildings, transport, water sources for instance. If children can not play can they develop as scientifically literate beings, problem solvers, communicators?.

## **10. References**

- [1] Alexander R. Towards Dialogic Teaching: rethinking classroom talk. Cambridge. Dialogos; York; 2008.
- [2] Bruner JS, Goodnow JJ, Austin GA. A Study of thinking. New York: John Wiley, Science Editions, Inc;.1956.
- [3] Bruner J. The process of Education. Harvard. Cambridge; 1977. Revised edition Bruner, Goodnow, Markman; 1977.
- [4] Chin C. Teacher questioning in Science Classrooms: Approaches that stimulate Productive Thinking. Journal of Research

- in Science Teaching. 44(6) 815-843; 2007.
- [5] Halliday MAK. Towards a Language-based theory of Education. Linguistics in Education 5; 1993.
- [6] Gopnik A. The Philosophical Baby: What Children's Minds Tell Us About Truth, Love, and the Meaning of Life. New York, USA: Farrar, Straus and Giroux; 2009.
- [7] Markman E. Categorization and naming in children: Problems of induction. The MIT Press, Cambridge Mass; 1989.
- [8] Moyle's J. Just Playing? The Role and Status of Play in Early Childhood Education. Maidenhead. Open University Press. 1989.
- [9] Pell T, Jarvis T. Developing attitude to science scales for use with children of ages from five to eleven years. International Journal of Science Education 23(8),847-862; 2010.
- [10] Robson S. The Analysing Children's Creative Thinking Framework: development of an observational led approach to identifying and analysing young children's creative thinking. British Educational Research Journal. 40 (1) 121-14.;2014.
- [11] Robins G. Praise Motivation and the Child. Abingdon, Routledge;2012.
- [12] Roth Wolff, Michael Goulart, Maria Ines Mafra, Plakitsi, K. Science Education during Early Childhood. A cultural – historical Perspective. Dordrecht. Springer; 2013. p.14.
- [13] Sylva K, Roy C, Painter M. Child watching at Playgroup and nursery school. London: Grant McIntyre; 1980.
- [14] Tizard R, Hughes M. Young Children Learning: Talking and Thinking at Home and at School. London: Fontana; 1984.
- [15] Wood E. Wonder why our dog has been so naughty? Chapter 2 in Robson S and Flannery Quinn (Eds). The Routledge International Handbook of Young Children's Thinking and Understanding. UK: Routledge, Abingdon;2015.
- [16] Whitebread D, Basilio M, Kuvalja M, Verma M. The importance of play: a report on the value of children's play with a series of policy recommendations. Brussels: Belgium: Toys Industries for Europe; 2012.
- [17] Vygotsky L. Mind in Society. Cambridge. MA: Harvard University Press; 1987. p.87.
- 
-

## Efficiency of Inquiry-Based Education: Guided Research vs. 'Blind' Brainstorming

A Kazachkov<sup>1</sup>, M Grynova<sup>2</sup>,  
JC Moor<sup>3</sup>, R Vovk<sup>1</sup>

<sup>1</sup>V. Karazin Kharkiv National University,  
Kharkiv, Ukraine

<sup>2</sup>Poltava V.G. Korolenko National  
Pedagogical University, Poltava, Ukraine

<sup>3</sup>Colorado State University, Fort Collins,  
CO, USA

akazachkov@yahoo.com

**Abstract.** A discussion is suggested on the important problem of balancing students' guided and independent research in the frames of the Inquiry-Based Science Education model. Experience of the class practice and summer academic programs (USA, Ukraine, Slovakia, Czech Republic, and Mexico) is analysed. Important examples are referenced including some creative hands-on activities for the school and college students.

**Keywords.** IBSE, efficiency of education, hands-on science projects, equilibrium.

### 1. Open-ended educational research as an appropriate solution

Successful application of Inquiry-Based approach to Science Education is barely possible without finding the due balance between students' independent observations & research and instructors' guidance of their creative activities [1]. Every teacher practicing IBSE should keep that in mind when planning lessons and educational research projects. A natural solution is to try and have the problems open-ended, which is usually the case when they are taken from the best IBSE books, ones like [2]-[4]. Then after the success of the guided stage of the class activity or a project students get inspired and skilled enough for the step next of the problem, an independent research or design.

### 2. Pitfalls of the students' brainstorming of the research problem

It is often pretty tempting for the teacher to let the students brainstorm the educational research problems, especially the ones resulted from the own observations of the

learners. The numerous pitfalls should be accounted for, though. Among the most dangerous for young learners may be frustration of not coming up with the ideas that help solve the problem. Time factor is equally important: to make educational inquiry efficient, duration of the brainstorming phase should be carefully controlled. Nonetheless, instructors practicing guided students' research, especially in the form of the out of the class projects, should try and provide for the stage of the totally independent students' reasoning or/and hands-on work. In our experience, it is quite possible to organize projects so that while some young researchers may themselves find original solutions or ingenious designs, others will learn a real lot even from their conventional suggestions, especially after comparison with the non-standard ideas and more efficient solutions. To appreciate counter-intuitive, ingenious breakthrough ideas, to gain from experiencing them, one must be enough aware of the traditional, 'obvious' ways to solve the problem.

If the brainstorming phase of the project is ignored, students may very likely only memorize the solution of the problem given by the instructor, however original that may be.

### 3. Guided research first?

It is the core of the IBSE method that in the process of learning students develop research skills which are to be applied and practiced before long. Teachers' guidance should be strongly focused on that as well as on the development of the students' creativity. It is no secret at all that both fundamental and applied research techniques are too often overly routinized. Educational inquiry should as much as possible provide for the creative steps taken by the young researchers, rather than for their direct copying of the earlier tested and proved techniques of the 'adult' science.

Special attention during the guided research is on the students' questions, comments and suggestions, even on the *seemingly* erroneous and minor ones. Examples from the authors' earlier educational practice of some best students' feedback to guided research could be found in [5].

Should be noticed separately that many the traditional bright and counter-intuitive solutions shared by the instructors with their students

bear neither explanation nor step-by-step consideration to let the learners conceive the rationale behind the scenario. It is desirable that the less 'perfect' though more justifiable solutions are suggested instead.

Examples from our teaching practice cover a variety of educational hands-on activities developed for the summer academic programs (USA, Ukraine, Slovakia, Czech Republic, and Mexico). They were intended to help develop construction and engineering skills of the students, their understanding of the basic principles of Physics and general research experiences. Dozens of students' conference reports and publications originating from those projects, include the paper in the high rating *The Physics Teacher* journal [6] co-authored by the then college sophomore student Dmitry Kryuchkov, a key person of the project to measure atmospheric pressure with the apparatus built from the most conventional materials.

#### 4. References

- [1] Inquiry and the National Science Education Standards: a guide for teaching and learning. Washington D.C.: National Academy Press; 2000.
- [2] Walker J. The Flying Circus of Physics. New York: Wiley; 1977.
- [3] Gardner M. Entertaining Science Experiments with Everyday Objects. New York: Dover; 1981.
- [4] Ehrlich R. Turning the World Inside Out and 174 Other Simple Physics Demonstrations. Princeton: Princeton University Press: 1990.
- [5] Kazachkov A. Creative Hands-On Activities with Water, Paper and Wire. Proceedings of the 10th International Conference on Hands-on Science. Costa MFM, Dorrío BV, Kireš M (Eds.); 2013, 1-5 July; Košice, Slovakia. Pavol Jozef Šafárik University; 2013. p. 281-284.
- [6] Kazachkov A, Kryuchkov D, Willis C, Moore JC. An Atmospheric Pressure Ping-Pong "Ballometer". *The Physics Teacher* 2006; 44(8): 492-95.

## Potential of Science Club Networks for Science & Technology Popularization and Communication

*B Kumar-Tyagi, V Prasar  
Apeejay Stya University, Sohna, India  
bktyagi@vigyanprasar.gov.in,  
tyagi.bk@gmail.com*

**Abstract.** The paper defines the dynamics of science clubs as robust platforms to communicate science and technology as decentralised approach to enhance public understanding of science and technology. Across the world, a variety of science clubs and networks of science clubs are active. The potential of science clubs as decentralised centres of science communication for social transformation is however yet to be explored. The paper highlights the basic philosophy, current status, and developments pertaining to science clubs based on literature survey, consultation meets and focus group interactions within the framework of several current models of science communication.

**Keywords:** Science Clubs, Science Popularisation Science Communication, VIPNET, Eco Clubs, Classical Club, Radical Club, Hybrid Club.

### 1. Introduction

The dynamics of science clubs presents them as robust platforms for communicating science and technology aligned with several local level considerations. This is in the context of the fact that people need to understand the pervasive nature of science and technology today more than ever before, as these two aspects influence all aspects of life. In all democratic forms of government an increasing number of people are involved in decision making at the local and the national level. Such scientific and technological issues as nuclear energy, global warming and climate change, preservation and conservation of biodiversity, genetically modified crops, etc., dominate the development mosaic. These are important themes of engagement and need to be debated before national policies are formulated. To generate meaningful and effective debate, the public needs to be well informed and updated on information so that informed decisions can

be made. A robust decentralised approach to enhance public understanding of science and technology is therefore essential.

The present paper is in response to felt need to consolidate our understanding of science clubs as enablers of knowledge centred engagement for the benefit of students and communities associated with them. Science clubs appear to grow in variety and number across various geographical and cultural and geographical landscapes that determine specific areas of knowledge inputs. National missions create the opportunity to converge on objectives. They are quite clearly unique non – formal learning platforms and will have to be interpreted for factors that determine their output and impacts. While a large scale synthesis has to be done on the basis of much needed empirical evidences about expected and actually delivered impacts, the present effort to consolidate some insights in this regard, creates a positive setting for science clubs. They serve formal and non – formal curricular needs and are nimble to serve highly divergent knowledge areas. It is essential to create location and knowledge specific synergies in this context.

Currently, several approaches and media are used depending on the local need and institutional mechanisms that enable such interactions. Every form has its own significance, utility and limitations as well. Such institution as science museums, science cities, satellite and cable TV and radio, specialised agencies for S&T communication, and government and non-governmental organisation play their role quite effectively in taking science to people. These approaches are however capital intensive and are based on the deficit model of S&T communication. For example, India's manifold diversity including cultural, social, religious, linguistic and regional is unique and staggering. Importantly nearly 65 % of her population are in rural settings and a significant part of them is not literate. The reach of mass media among citizens except radio, is still limited. These ground realities present a formidable challenge to science communicators. In such a scenario, centrally planned strategies, albeit through modern means of communications do not stand much chances of success. Any strategy to be effective should be "participatory and in the local language through channels of

communication, people are familiar with". Across the world, a variety of science clubs and networks that optimize on their output are active. These clubs are supported by national governments and even such international bodies as the UNESCO. Some networks of science clubs have significantly long histories dating to the beginning of the nineteenth century. Some such networks of science clubs worth mentioning are in the United States of America, Canada, and the STEM clubs of UK, Federation of Young Farmers Clubs, VIPNET, DNA and Eco-clubs in India.

VIPNET Clubs have been involved in some of the major campaigns built around solar eclipses, biodiversity, water, etc. The clubs have established their use value in taking science to the people. These involve debates, surveys and demonstrations, performing experiments, and answering the queries of citizens at the local level. Over the years clubs activities have been transformed essentially into people-oriented activities. They are not confined to formal classroom or laboratory experiments, nor do they provide any bookish or theoretical knowledge. They invite and involve people to see, do and learn things by themselves and find out the truth. This has helped promote scientific literacy among common people. Several studies indicate that the activities of clubs, museums as out of school time science, non-formal, informal science learning, have established a positive correlation between the attitude towards science and their engagement with science. The potential of science clubs as decentralised centres of public engagement for science literacy through S & T communication and intended social transformation, is however yet to be explored. Most of the research undertaken specially in USA and UK is related to science museums only.

A snapshot of the history of science clubs reveals interesting engagement outcomes. Science became part of the school curriculum in Europe and the USA in the 19<sup>th</sup> century that witnessed growing visibility of science in all public spheres. The term "scientist" indicated generator of knowledge through systematic pursuit based on method of science or inductive logic in contrast to deductive logic, a dominating thought process at that time. The era saw significant interest in science. The focus therefore, was satisfying curiosity and

promoting independent attitude, provide a broad understanding of the natural world and the way it affected people's personal and social lives.

The dilution happened during the world wars and post war periods. This was arguably due to growing cynicism based on the perceived negative impact or misuse of science and Technology (S&T). It cannot however be denied that S&T development delivered multiple and large scale benefits despite the war. But after the launching of Sputnik by Soviet Union in 1957, the emphasis shifted to the strategic value of S&T rather than its relation with day-to-day life. This was particularly in the western world. The emphasis of disciplinary knowledge removed from everyday life application was a marked shift in science education. This period witnessed the emergence to STEM Clubs, promoting disciplinary approach of science learning and doing with an objective to enhance the number of scientists and engineers. Interestingly, the couple of last decades also saw equally large number of uncertainties that emerged along with tangible benefits of technological development. Bio-technology and nanotechnology are a few such typical cases. This called for a deeper understanding of the basis of origin of scientific investigation, the limit & limitations of tools and technology and most importantly their implications for public policy.

This framework of analysis with specific reference to the role played by science clubs in school and in community has been used in the literature review.

Interestingly, post 1990 saw several science clubs in schools especially in India, reach-out to communities for two very important purposes. They were to

- Help communities comprehend benefits of formal science learning to enrich the latter's perspective on science &.
- Gather insights from the community to re-enforce application of science in daily life through formal and informal learning.

This was, particularly for the benefit of the children in schools, who could, therefore look at science in the real life connect.

It is pertinent to mentioned that theoretical

and empirical research in science communication or Public Understanding of Science (PUS), has relatively a short history compared to long standing practice of PUS (Massimiano Bucchi 2008) [1]. However, since 19th century science clubs have served as robust mechanism to promote science in general and science literacy in particular among students and lately, in the community as well through outreach programmes. Some earliest reference of nature clubs, mainly for bird watching has been found in some Scandinavian countries like Denmark. It was in 1992, a dedicated scholarly journal, "Public Understanding of Science" emerged. Previously the scholars relied on journals of sociology, education and more recently on media studies. Though the form and structure of the science clubs has changed over the years, they have served as robust platforms for PCST with special reference to informal science learning, free-time science, non-formal science, museums etc; now an established field of inquiry.

## 2. Review of Literature

Through the literature survey, the evolution of science club movement has been traced along with the spread of priorities, focus and the structure of science clubs, their changing priorities of science education (science literacy to process of Science) and approaches/model of science communication/ popularization. The latter has shifted from scientific literacy to public understanding of science and finally to people engagement in science and technology. Nearly 147 research papers, articles, reviews, concept papers, opinions, editorials and reports were analysed using some important hall marks. Through this review, an attempt has also been made to understand the:

- Evolution of science club movement since 18 century, when science became the enterprise of enlightenment.
- Assess optimism about science and its influence on activities to popularize science, methods, approaches and formation of association for the advancement of science and similar bodies in Europe, North America, Latin America and Asia.
- Vector dynamics of science clubs to popularize science and creating scientific attitude, a term synonymous with scientific temper as used in Indian discourses.

The review below reveals interesting transitions over specific periods of time.

### 2.1. Science Clubs (1906-2014)

Articles relating to science clubs were published between 1906-1950, in journals like "School Science and Mathematics", "International Journal of Science Education" describing nature, structure functions and their potential for science learning. An analytical study of 35 separate articles relating to science club was undertaken by Ethel L Roberts [2] in 1932. In 1941, the journal Nature [3], reported about the Science clubs of America. A series of UNESCO documents published from 1949 to 1956 gave a descriptive account of Science clubs movement in different parts of the world and its role.

The Davis Layton [4] paper, "UNESCO and Teaching of Science and Technology" provide insights about development across the world in education that influenced the structure, functions and the programme and activities of the clubs. "Popularization of Science and Technology: What informal and Informal Education Can Do?" an online compendium by UNESCO (1989) [5] again examined "how non-formal and informal education can contribute to helping people in achieving the scientific literacy to function effectively in a society. Nina S. Robert (2009) [6] evaluated the effectiveness of eco-clubs of India and assesses the organizational framework. Three studies by *Alpaslan Sahin* [7], *Michael A Gottfried* [8] and *Allan Feldman* [9] provide an insight about the impact of STEM clubs on student attitude toward science and its relationship with students opting the STEM subjects for higher studies.

The genesis and the growth of science clubs movement in India was examined by Sabyasachi Chatterjee (2013) [10]. Kinkini (2013) [11] described the significant role played by clubs in inculcating an interest and build understanding about world of science among students. Tyagi B.K (2014) [12] highlighted the possibility that children could undertake projects through a suitable platform like science clubs at school with some minimal facilities".

### 2.2. Informal Science interface with science clubs

In 1999, Lynn Dierking and John Falk [13]

(USA) focused on the organization's positioning in regard to out-of-school science education. The statement defines learning in out-of-school contexts at places such as museums, the media, and community-based programs. Laura M. W. (2004) [14] recognized the fact that science centres, museums and other informal educational institutions can play a role in the reform of science, technology, engineering, and mathematics (STEM) education and defined the "emerging research framework for studying informal learning and schools Science Education".

Falkenberg et al (2006) [15] established the fact that students who participate in afterschool programs achieve higher grades and higher standardized test scores than students who did not participate in afterschool programs by citing a number of research studies. Justin Dillon et al (2006) [16] examined 150 pieces of research on outdoor learning published between 1993 and 2003. David A. Ucko (2010) [17] conducted a study to establish a base for future research, to provide evidence-based guidance for those developing and delivering informal learning experiences. The Wellcome Trust (2011) [18] report attempted to define the attributes of informal learning. "Nature (2010) [19] editorial on the value of informal science learning also made a very passionate call to policy makers for paying more attention, and more money on informal science education. Molly Phipps (2010) [20] in his analysis concluded that the decade from 1997–2007 was transformative for research in the context of learning in out-of-school from individual programmatic needs to a field with a coherent conceptual framework to guide research. Lewenstein et al [21] discussed and organized hundreds of documents on pedagogical premises, places, practices and pursuits concerning scientific informal education.

### **3. Science Popularisation / Communication: A science club correlate**

The term "science communication" operationally, encompasses a range of related fields of professional practice and to a field of study which is predominantly interdisciplinary in nature. There is a plethora of literature that defines the field of science communication and it is becoming institutionalized in several countries around the world. Being a complex network of social channels "SciCom, serves as a mechanism for bridging the gap between

scientific community and the public (Monjib Mochahari 2013) [22]. It is also an effective tool for extending scientific boundaries and gaining wide public support for important research and development, which are indispensable for society's development" (*Patariya 2002*) [23]. In practice, the terms science communication or science popularization are used interchangeably in India. In western literature, many terms, specially for research, have been used i.e. "public awareness of science" "public understanding of science (PUS)", "public understanding of science and technology (PCST)", "public engagement with science and technology (PEST) or " public appreciation of science".

However, over the decade, the complexities of science communication have been magnified as a result of many social and technological changes. Science itself no more remained as compartmentalized discipline. It is interdisciplinary, global in approach and scale, more focus on applications than fundamentals, with changed funding patterns, (funding of research by corporate and other big private players) and most importantly, the transformation of media due to IT revolution by creating new opportunities to communicate. It therefore hinges on the need to build trust specifically in science, with new two-way communication models, approaches and strategies involving elements of engagement, understanding and participation through a variety of mechanisms. It has changed from monologue to dialogue, linear to two-ways, all directed towards informed decisions making as a part of social and democratic process. Today, science communication has its theoretical framework with science communication models, networks of communities with international reach with dedicated research journals and science communication courses are being offered in the universities across the world.

### **4. Science Popularization in India (2002-2013)**

A chronological account of development of science communication movement in India was given by Patrariya (2002) [24] along with institutional mechanism and nationwide programmes of science communication like Jathas, National Children Science Congress etc. The India Science Report 2005 (ISR) [25],



presented quantitatively the state of science and technology in India along with an insight into the public understanding of science. The National Curriculum Framework (2005) recognized the importance of informal science learning for the first time in India and suggested the mechanism of science club for informal science. Nautiyal (2008) [26] analyzed the current science popularization scenario in India and brings out the fact that rural people also carve for S&T information and need it as much as the rest of the people. Bhaskar Mukherjee (2009) [27] emphasized that “it is not enough to focus on the generation of knowledge but it is equally essential to spread and share it”. Gauhar Raza et al (2009) [28] presented Public Understanding of Science (PUS) as an area of academic discipline evolved in India. Abdul Gafoor et al (2010) [29] conducted an empirical study to analyze and explore out-of-school science experiences and interest in science of upper primary school pupils of Kerala. Dr. A.P.J Abdul Kalam (2011) [30] highlighted the role of science communication as how “it is an asset to the transformation of society” and laid an agenda before science communicators.

On the basis of literature survey, it can be concluded that science communication is well established as a practice in India, but a significant gap is observed in term of science communication as an area of research or inquiry. The number of researchers and scholars and journals are quite few in comparison to the western world. However, the Indian experience as practice in this field may have much to offer to researchers for theorization.

These aspects set the context for a reality check on the form and function of science clubs in India.

### **5. Preliminary Findings of literature survey, focus group discussion and interviews of Stakeholders**

i. There are various types of science clubs network which are either affiliated with a International, National/State/Regional Level Network. Majority of these networks are either initiatives of International bodies or National or State level government in India. There are some networks which have been initiated by some state level organizations or some enthusiastic individual science

communicator. There are some independent science clubs as well, not affiliated with any network.

ii. The clubs can be classified as classical, radical and hybrid on the basis of objectives, philosophy, form and structure as follows:

a. **Classical clubs** are mainly those that promote interest in basic science or STEM mainly through hands-on activities by the process of exploration and self discovery. Clubs on Chemistry, physics, bio, electronic and robotic clubs mainly fall under this category. The genesis of such clubs may be seen in the beginning of 19<sup>th</sup> century with the growing visibility of modern science in all public spheres especially in USA and Europe. In India the growth of science club movement had its roots in the national movement to fight colonial exploitation and inculcate rational thinking as the society was seen by elites educated in modern science, as steeped in obscurantism, superstitions lacking rational thoughts. (TV Venkateswaran) [31].

b. **The radical clubs** promote interest in science mainly through awareness and outreach activities not confined to STEM. They focus on science and society related issues as “Science for All” involving conservation of local natural resources and energy, environment, etc as well. The structure and functions of radical clubs in India has been influenced, to a great extent, by the People’s Science Movement (PSM) of India; rooted deeply in social reformists thinking of late 1950s. The science clubs of West Bengal, Karnataka, Kerala, Bal Sabhas of Haryana and theme specific clubs like eco-clubs of India, Nature club of WWF are some examples of radical clubs.

c. **The hybrid clubs**, like VIPNET, are a mix of both in structure, functions and origin.

iii. The classical clubs has emerged in new form in western world with new structure, function, approach and operational mechanism in the form of informal science education or after school science with new stakeholders and players with or without government support.

- iv. Not much has been reported on the dynamics (structural and functional) of science club, notwithstanding some location specific reports and publications, mainly descriptive in nature. The larger potential of science club reaching out to community is yet to be documented, interpreted and reported.
- vi. The shifting paradigms of Public Understanding of Science and Technology Communication along with its problems and solutions has influenced the Structure and Functioning of Science Clubs as well.

## 6. Classical Clubs: Promoting Interest in Basic Science like STEM Clubs

A number of studies have supported STEM initiatives of governments in influencing the attitude of children towards science. Bennett reported (1956) [32], on science clubs of Britain, and related attitudes in learners towards science. Mannion and Coldwell (2008) [33] investigated 250 schools in England, and found that learners' involvement in their club became more positive the longer they had been a member along with improvements in practical skills, self-confidence and thinking skills of staff and leaders. Additionally their understanding of science, mathematics and engineering improved albeit to varying degrees. Some other studies in other country have empirically proved the role of clubs in promoting the interest and engagement in science. In Portugal, Viegas, (2004) [34] suggested that a science club was an important vehicle for developing scientific interest in schools. Twillman (2006) [35], reported a change in attitude of learners. This improved attitude towards science was also reported by Moore-Hart, Liggitt and Daisy (2004) [36] Youth organizations such as 4 H, Big Brothers Big Sisters, Boys & Girls Clubs of America, Girls Inc., and the YMCA of the USA have recently joined hands to make STEM a priority (cited by Hartley 2014) [37] As per Anita Krishnamurthi 2014) [38] this initiative has the potential to infuse better quality into curricula, activate interest and mentor millions of children and youth. Twillman (2006) also found that the science club gave members the opportunity and space to express curiosity, and members often gained a sense of belonging to a community they valued.

A study by Feldman and Pirog (2011) [39] reported that within an academic year, teachers

were able to gain the knowledge and skills to facilitate children's participation in authentic scientific research and developed methodological and intellectual proficiency needed to contribute useful data and findings to research programme carried out by scientists. The results of this study are also supported by the findings of Hartley (2010) [40], who used a similar approach of training and mentoring teachers to pass on their knowledge and skills to learners in science clubs at their schools.

Afterschool Alliance (2011) [41] summarized STEM-specific benefits into three broad areas as 1). Improved attitudes towards STEM fields and careers, 2). Improved STEM knowledge and skills, and 3) a greater likelihood of graduation on and further pursuing a STEM career. As reported by Hurtley 2014, the results from the 2009 National Assessment of Educational Progress (NAEP) in science also showed that 4th graders who participate in "hands on science activities" and 8th and 12th graders who did "science related activities outside of school" showed a significant increase in test scores compared to those who did not. The outcomes of the clubs are not necessarily about increased academic achievement but striving to increase involvement and exploration with STEM. This could also decrease anxiety around STEM, and enhance motivation in equal measure for young men and women.( Dabney et al. 2011). Tan et al. (2013) examined middle school girls' experiences in school day science classes and outside school time (OST) science clubs. They suggest that the positive science identity development that takes place within OST environments may impact girls' science trajectories and career goals. The Center for Research on the Education of Students Placed At Risk (CRESPAR) reviewed research on 34 extended-day and afterschool programs (Fashola, 1998). The study concluded that these types of programs appear to have positive impacts on children. (*Studies mentioned above has been reported in Afterschool Alliance 2011- "Examining the Impact of afterschool STEM Programme"*) All these studies clearly established the influence of classical clubs in creating a positive attitude towards science along with engagement for better understanding of STEM subject.

## **7. Evaluation of Radical and Hybrid Clubs**

However the literature on the evaluation and impact assessment is scanty. The activities of such clubs are difficult to assess because most of the activities of these clubs are in the form of outreach and organised in informal settings. In India there are two major network of Science clubs i.e. VIPNET Clubs of Vigyan Prasar [42], Department of S&T, Gov. of India, and Eco Clubs of Ministry of Environment and Forest [43] along with comparatively small network of DNA Clubs [44] of Department of Biotechnology, Govt of India. Initially VIPNET network members were motivated to take up scientific activities and contribute towards its cherished goals of achieving a scientific culture in the society. The present strength of the clubs is about twelve thousand, in all the States of the country and many of them are outside the school setup unlike eco or DNA clubs. The network member has been involved in some major campaigns built around the theme solar eclipses, Biodiversity, Water, etc [45]. Over the years VIPNET clubs activities has been transformed essentially into people-oriented activities. They invite and involve people to see, do and learn things by themselves and find out the truth. These science club activities have become a strong link between the science and community. (VIPNET Brochure 2009) [46]. A self study was undertaken by Vigyan Prasar suggested "that science clubs have played a significant role in inculcating an interest and build understanding about world of science among students". Around 80 % students opined that Science Clubs are giving information beyond syllabus" (Kinkini et al 2013).

Eco-Clubs of National Green Corps, is a programme of the Ministry of Environment and Forests, Government of India covering around 1,20,000 schools in India. "The aim of Eco Clubs is to introduce environmental concerns and good practices to school children to make them actively involved and to be aware of the need to protect". In a study Nina S. Robert (2009) documented and evaluated the effectiveness of eco clubs and assesses the organizational framework of 97000 clubs after an extensive review of secondary data and two focus group interviews at two locations. The findings shows that the "partnership programme developed with school and NGOs

to propel eco-clubs concept forward and contributed greatly to their ability to provide ongoing quality programme for the students". However suggested" different agencies should work cohesively". A similar study was conducted in Ibadan (Nigeria) to assess the contribution of Youth Environmental Scout (YES) clubs towards sustainable environmental programme in selected schools.( G. R. E. E. Anaa 2009) [47].

In all the studies the evaluation has been done from the perspective of students and their attitude towards science. However, their impact on society in term of understanding and engagement is yet to be analyzed. Though, some broad observations can be made in terms of participation and engagement of people in various campaigns organized in last five years. In these campaigns various model, which are currently debated in the academic circles, have been used to devise communication strategies using multimedia approach for ensuring large-scale engagement and participation.

## **8. Communication Models and Club Network Approach for Sci. Com**

The purpose of science communication always remained so diverse, guided, influenced and shaped by so many external and internal factors at a particular time. But behavioural change, impacts of S&T on society and its future, especially the technology options, the growing acceptance of S&T and improving scientific literacy always remain the core concerns of science communication. For this purpose a wide variety of approaches, media and strategies are being used. Today Science communication is constantly growing and evolving in two ways: - on academic front and as an area of practice. It will continue to be so with increasing scientific knowledge and the growth of new media riding on internet revolution. Science communication appears to have grown from the deficit model of communication to dialogic and finally participatory. Newer approaches are being experimented by the practitioner to reach to a variety of publics mainly through diffusion of information.

The theory of two-cultures as propounded by the C.P. Snow still remains valid in practice as there is always an information deficit among various publics that needs to be filled. In practice the deficit model of communication

remained a dominant model. As Trench [48] concluded “The model survives as an effective underpinning of much science communication and “a legitimate case can be made for retention of a dissemination model in certain circumstances. In fact, there may be several factors that determine the choice of communication approaches. For example if communication is for science literacy, the obvious choice will be the deficit model. But if it is for policy formulation or technology options involving ethical or other social issues, the choice would definitely be dialogic or participatory. Since, Science communication as a process is becoming increasingly complex and adopting only a particular model for all situations will not be appropriate, in fact, prove counterproductive. Even some time for developing meaningful dialogue or ensuring effective participation, some information gap need to be filled. Further there is a diversity of publics for science and same is the diversity of possible approaches to communication. All the three models have their utility in a particular situation. In fact all the three models can also co-exist together, depending upon a situation, provided they may be not seen as oppose to each other, but mutually inclusive and complementary. The situation can be well explained with Indian example of VIPNET clubs.

## **9. Learning’s from campaigns**

In 2009-2010, two major campaigns were organized involving these clubs around the celestial phenomena, i.e. Solar eclipse of July 22, 2009 & Annual Solar Eclipse of January 15, 2010 [49]. In India a number of myths, superstitions and unscientific beliefs are associated with eclipses. The campaign was an attempt to fill the information gap about the phenomena of eclipses by developing a meaningful dialogue about fears and misconceptions associated with eclipse for ensuring the participation for group viewing during the day of eclipse. For this:

- i. A wide variety of resource material was developed in consultation with a number of stakeholders like scientists; S&T based NGOs, Media organisations, science writers, communicators etc. (Participatory model). As result basic core content in the form of print material, films, CD ROMs, VCD, DVDs poster, activity kits etc were developed. A

dedicated websites were also developed (for dialogues) and a series of trainings were also organised. (Deficit Model).

- ii. The material was translated, adapted and modified as per the local needs for further dissemination by the clubs with the help of other stakeholders. The dialogues were created by the clubs with community through demonstrations, lectures, debates and surveys to dispel the myth and superstitions. A series of hands on activities in the form of small projects were also undertaken. On the day of main event, around 4 experiments were conducted by the children. As per the analysis, the accuracy of the result of these experiments were between the ranges of +-30%. More than 200 hundred places, group viewing of eclipse were organised. (Participatory).
- iii. This campaign clearly demonstrated that all the three model of communication could be used simultaneously in a well designed communication strategy in a more contextualized manner by using familiar channel of communication among various publics.

## **10. Science Clubs Networks: Areas to be explored**

An exercise of review and brainstorming to decide road map of science club was undertaken by VP in August 2012 [50]. The lack of periodic training to the leaders/coordinators, shortage of new ideas for activities and inadequate finance are some of the major issue which need to be address on priority basis to make the club network approach of science communication more effective. Further, it was found that majority of these clubs do not have any mechanism to evaluate their own activities in terms of impact. The tool kit for clubs associated with outreach and engagement activities needs to be developed besides documentation of good practices of science communication especially in relation to science and society.

There are more such areas where science club mechanism can be used for expansion and deeper penetration into the society for science communication objectives. A few such areas need further exploration, research and synthesis are as follows:- Science clubs.

- i. Can be identified initially at district level to act as information clearing house for other

- clubs and the community as well.
- ii. Could be the precursor for developing science centres at district or further downward levels.
  - iii. Could serve as science shop or service providers on the line of scientific consulting research model, developed in the Netherlands in 1970, and used throughout Europe, a knowledge producing institution (i.g university) function as consultant to community group to answer questions raised by the community group (Leydesdorff & Ward 2005) [51]. In the process, the community group is empowered to use scientific information to solve a problem.
  - iv. Can help network for participatory Action Research: - Which begins with the interest of participants, who work collaboratively with professional research & through all steps of scientific process to find solution to problems of community relevance.
  - v. Develop, adapt and translate resource material to be used by suitable channels for local communication.
  - vi. Engage in citizen science.
  - vii. Enable effective dialogue with society across to take into account the value and attitudes of the public especially on issues have ethical, social and environmental dimensions.
  - viii. Motivate coordinate public engagement in some action oriented activities like wildlife conservation, environmental protection, Natural Resource management & conservation at local level &
  - ix. Build capacities to coordinate action in response to natural/man- made disaster, epidemic etc.

## 10. Conclusion

The paper has presented a gross synthesis of perceptions about science clubs and set the context for further investigations on the dynamics of their output. Some patchy inferences appear to support the case for science clubs in schools as platforms for community engagement. While their positive potential is obvious, they have to be supported with a deeper understanding of the dynamics of transforming learning to action in real life by beneficiaries of clubs' activities. We can speculate that these will be positive on a cumulative framework. That science clubs are also decentralized entities is quite clear, yet aligned with larger institutions. The singular

take away is the need to theorize on the above so that suitable policy related measures can be devised to strengthen them further. The snapshot presented in this paper is a unique effort at consolidating our understanding of related dynamics.

The annual reports of the institutions that run the clubs referred in this analysis present information about the output achieved in terms of the number of beneficiaries and knowledge products delivered, they do not provide deeper insights about the logical framework of the choice and tools of delivery and impacts on learning or action enabled as a consequence. It will be useful to carry out a detailed analysis of the constraints that impose themselves on the intended purpose and optimal delivery to devise appropriate structures of governance. Synergies and locally adapted knowledge products that build on the strengths of the people using them at the local level will enhance the qualitative and quantitative profiles of the benefits through science clubs. A compendium on the successes and related knowledge systems will be a useful starting point to consolidate efforts in this context.

## References

- [1] Massarani L, de Castro Moreira L. Popularisation of Science: Historical perspectives and permanent Dilemmas. *Quark*; No 23, 2004 April-June.
- [2] Roberts El. A study of Science Clubs as portrayed by current science Magazines article (Ethel L Roberts) *School Science and Mathematics*, Volume 32, Issue 9, p 948–953, December 1993
- [3] Science Clubs of America. Editorial, *Nature*, 148, 590-590 (1941 November 15)
- [4] Layton D. UNESCO and Teaching of Science and Technology (<http://www.unesco.org/education/nfsunesco/pdf/LAYTON.PDF>) [visited 21-May-2014]
- [5] Popularization of Science and Technology: What informal and Informal Education Can Do?" UN Sponsored conference in September 4-9, 1989, at Hong Kong ([unesdoc.unesco.org/images/0012/001263/126341e.pdf](http://unesdoc.unesco.org/images/0012/001263/126341e.pdf)) [visited 5-May-2014]
- [6] Robert NS. Impacts of the National Green

- Corps Program (Eco-Clubs) on students in India and their participation in environmental education activities. *Environmental Education Research: Volume 15, Issue 4*; 2009. p 443-464.
- [7] Sahin A. STEM Clubs and Science Fair Competitions: Effects on Post-Secondary Matriculation; *Journal of STEM Education*, vol14(1). 2013. p 9.
- [8] Gottfried MA, Williams D. STEM club participation and stem schooling outcomes, *Education policy analysis archives*; vol 21; 2013.
- [9] Feldman A, Pirog K. Authentic Science Research in Elementary School After-School Science Clubs; *Journal of Science Education and Technology*. 01/2011; 20(5):494-507.
- [10] Chatterjee S. Changing Role of Science Clubs in Communicating Science; *Global Media Journal – Indian Edition*; Summer Issue; Vol.4, No.1; Jun 2013.
- [11] Kinkini Dasgupta Misra, Bhushan KB, Upadhyaya RK. Science Club: An effective tool for promoting awareness temper for Social Science & Interdisciplinary Research; *IJSSIR*, Vol. 2 (3); Mar 2013. Online available at [indianresearchjournals.com](http://indianresearchjournals.com)
- [12] Tyagi BK. *Science Education*; Vipnet News (12); 4-Apr-2014, p1-3.
- [13] Dierking L, Falk J, Rennie L, Anderson D, Lynn D. Policy Statement of the “Informal Science Education”. Ad Hoc Committee (Policy Statement), *Journal of Research in Science Teaching*, vol. 40, no.2, p 108-111; 2003.
- [14] Martin LMW. An emerging research framework for studying informal learning and schools *Science Education*; Volume 88, Issue Supplement 1, p S71–S82, Jul-2004; (Supplement: In Principle, In Practice: Perspectives on a Decade of Museum Learning Research (1994–2004).
- [15] Falkenberg K, McClure P, Mc Comb EM. Science in Afterschool literature Review; Developed by the SERVE Center (<http://www.sedl.org/after-school/toolkits/science/pdf/SERVE%20Science%20in%20Afterschool%20Review.pdf>) [visited 14-Jan-2015]
- [16] Dillon J, Rickinson M, Teamey K, Morris M, Young Choi M, Sanders D, Benefield P. The value of outdoor learning: evidence from research in the UK and elsewhere. *School Science Review*; Mar 2006, 87(320).
- [17] David A. Ucko, *The Learning Science in Informal Environments study in Context*; Report published in *Curator*, 53(2):129; 2010.
- [18] Matterson C, Holman J. Reflections from the Wellcome Trust. Report; Reference [http://www.wellcome.ac.uk/stellent/groups/corporatesite/@msh\\_peda/documents/web\\_document/wtp040859.pdf](http://www.wellcome.ac.uk/stellent/groups/corporatesite/@msh_peda/documents/web_document/wtp040859.pdf). [visited 15-Jan-2015]
- [19] Learning in the wild: Much of what people know about science is learned informally. Education policy-makers should take note. *Editorial Nature* 464, 813-814; 8-Apr-2010.
- [20] Phipps M. Research Trends and Findings From a Decade (1997–2007) of Research on Informal Science Education and Free-Choice Science Learning Visitor Studies; Volume 13, Issue 1; 2010.
- [21] Bell P, Lewenstein B, Shouse AW, Feder MA (eds.). *Learning science in informal environments: people, places and pursuits*; by the US National Science Council by *Learning Science in Informal*; 2009.
- [22] Mochahari M. Revisiting India’s Science Communication and Journalism: Issues and, *Global Media Journal Summer Issue*; Jun 2013; Vol.4, No.1.
- [23] Pattairiya M. Science communication in India: perspectives and challenges. <http://www.scidev.net/global/communication/opinion/science-communication-in-india-perspectives-and-c.html>. [visited 25-May-2014]
- [24] Patairiya M. Emerging Scenario of Science and Technology Communication. *Indian Journal of Science Communication*. Vol. 1, No. 1. January-June; 2002.
- [25] Rajesh S. Science Education, Human Resources and Public Attitude towards

- Science and Technology. India Science Report 20005 Council of Applied Economic Research ([http://www.insaindia.org/pdf/India\\_Science\\_report-Main.pdf](http://www.insaindia.org/pdf/India_Science_report-Main.pdf)) [visited 25-May-2014]
- [26] Chandra Mohan Nautiyal. A look at S&T Awareness - Enhancements in India'. *jcom*, volume 07, (2); Jun 2008.
- [27] Bhaskar Mukherjee "Scholarly Communication: A Journey from Print to Web". *Library Philosophy and Practice* 2009. <http://digitalcommons.unl.edu/cgi/viewcontent.cgi?article=1298&context=libphilprac>
- [28] Raza G, Singh S, Shukla R. 'Relative Cultural Distance and Public Understanding of Science'. *Science Technology Society*: July- December 2009; vol. 14 no. 2269-287.
- [29] Gafoor KA, Narayan S. Out-of-school Science Experiences and Interest in Science of Upper Primary School Pupils of Kerala; *Journal of Indian Education* 2010; p29-36.
- [30] Abdul kalam A.P.J. Sharing Science 2011, Chapter1, p 1-5 (ed. Patariya M.K., Noguera M. I)
- [31] Venkateswaran TV. Narrative of Superstition and Scientific temper in India- A historical perspective. [www.jhc2012.eu/images/partenaires/tvv.pdf](http://www.jhc2012.eu/images/partenaires/tvv.pdf). [Visited 18-Apr-2014]
- [32] Bennett MG. United Nations Educational Scientific and Cultural Organization (UNESCO): Science clubs activities in the United Kingdom. Paris: UNESCO; 1956.
- [33] Mannion K, Coldwell M. After-school science and engineering clubs evaluation; 2008. (Research Report No DCSF-RW071). Department for Children, Schools and Families. Retrieved from [http://www.shu.ac.uk/\\_assets/pdf/ceir-ASSEC-DCSF-FinalReport.pdf](http://www.shu.ac.uk/_assets/pdf/ceir-ASSEC-DCSF-FinalReport.pdf) [visited 3-Jan-2015]
- [34] Viegas A. The importance of science clubs: Methods used in a school case. *Teaching Science*, 50(4), 22–25; 2004.
- [35] Twillman J. Science for fun? Try a high school science club; *The Science Teacher*, 73(1), 49–52; 2006.
- [36] Moore-Hart MA, Liggitt P, Daisey P. Making the science literacy connection: After school science clubs; *Childhood Education*, 80(4), 180–186;2004.
- [37] Hartley S. Science Clubs: An Underutilised Tool for Promoting Science Communication Activities in School; In book: *Communicating Science to the Public*; Edition: 1st, Publisher: Springer, Editors: Leo Tan Wee Hin & R Subramaniam, pp.21-32 ;2014.
- [38] Krishnamurthi A et al. Examining the impact of afterschool STEM commissioned by the Noyce Foundation 2014 ([www.afterschoolalliance.org/ExaminingtheImpactofAfterschoolSTEMPr](http://www.afterschoolalliance.org/ExaminingtheImpactofAfterschoolSTEMPr)) [visited 10-Feb-2015]
- [39] Feldman A, Pirog K. Authentic science research in elementary school after-school science clubs. *Journal of Science Education and Technology*, 20, 494–507; 2011.
- [40] Hartley MS. Investigating the science-related attitudes of learners at 5 secondary schools where science clubs have been established. A paper published in the proceedings of the 41st annual conference of the Australasian Science Education Research Association (ASERA); Jul 2010.
- [41] [Afterschoolalliance.org. Examining the impact of afterschool STEM programs](http://www.afterschoolalliance.org/ExaminingtheImpactofAfterschoolSTEMPrograms.pdf) <http://www.afterschoolalliance.org/ExaminingtheImpactofAfterschoolSTEMPrograms.pdf>
- [42] [www.vigyanprasar.gov.in](http://www.vigyanprasar.gov.in) [visited 14-Feb-2015]
- [43] MoEF, Govt. of India, Annual Report (2012-13) [visited 14-Feb-2015]
- [44] Department of Biotechnology, Govt. of India Annual Report (2012-13) [visited on 14-Feb-2015]
- [45] VIPNET News, July 2013, vol 11(12); p 5-9.
- [46] VIPNET Brochure 2009.
-

- [47] G. R. E. E. Anaa 2009, Contributions of Environmental Clubs Toward Improved Environmental Programs in Selected Secondary Schools in Ibadan, Applied Environmental Education & Communication, vol. 8, no. 2, p. 94-104; 2009.
- [48] Trench B. Model of science communication: How Many There Be? ([http://isotope.open.ac.uk/files/Text\\_extract-Trench.pdf](http://isotope.open.ac.uk/files/Text_extract-Trench.pdf))  
[Visited 17-Jun-2015]
- [49] Prasar V. Annual Report 2009-2010 p 47-50
- [50] Proceeding of Brainstorming Session on Science Club Movement in India, (Restricted Circulation) Published jointly by Vigyan Prasar and Gujarat Council on Science & technology; Gandhinagar 2013.
- [51] Leydesdorff L, Ward J. Public Understanding of Science, 14, p 353-372; 2005.
- 
-



## New Light to Relativity with Levers and Sticks

X Prado

IES Pedra da Auga, Ponteareas,  
Pontevedra, Spain  
xabier.prado@yahoo.com

**Abstract.** We propose the use of simple physical devices like balances, levers and sticks to understand modern concepts of relativistic physics like mass/energy equivalence or the generation of electricity by induction. The approach is based on the geometric formulation of relativity in spacetime by Minkowski.

To explain mass/energy equivalence we propose the use of ancient scales together with spacetime diagrams to gradually recognise the effect of the lever inclination on the equilibrium point and therefore on the relationship between mass and energy. For the explanation of electromagnetic induction we will show how the movement of a conductor stick, together with the relativistic effect of length contraction are responsible for the creation of the induction current.

**Keywords.** mass/energy equivalence, relativity, spacetime, electromagnetic induction.

### 1. Introduction

Hermann Minkowski, after Albert Einstein published his papers about Special Relativity (SR), stated that this theory has an essential geometric nature, with space and time joined together into a new physical entity which he called „spacetime“. Spacetime is endowed with a new kind of geometry, in which the speed of light plays the role of an „universal absolute“.

We propose to use this striking geometrical feature to develop teaching strategies to present relativity and its effects in a mainly visual way, thus allowing students to concentrate in the understanding of the reasons and consequences of this new kind of physical geometry.

The author has presented this idea as an interdisciplinary teaching unit for sophomore students [1]. It has been also the subject of a PhD these, whose content was presented at the ESERA Conference in Istanbul on 2009

[2], or, more recently, as a series of videos with animations which were presented at the 11th Conference on Hands-on-Science that took place on 2014 in Aveiro [3].

The aim of this paper is to enlarge the scope of physical effects that can be explained with this visual methodology, as well as the type of materials that can be used for this purpose.

We will focus on two physical effects: Mass/energy equivalence, with levers as the main didactic material for it, and electromagnetic effects, where we will use rods and sticks to explain how they can be derived directly from the relativistic length contraction.

### 2. Mass/energy equivalence with levers

The equivalence of mass and energy, represented by the famous formula  $E = mc^2$ , which is considered one of the most famous formulas of all times and an icon of relativity, can be easily interpreted and understood with the help of levers and balances.

The balance was one of the first technological advances of humankind, and its development and diffusion is being currently object of intensive study as an early example of innovation processes [4], [5].

#### 2.1. Balances with fixed fulcrum

The equal-armed balance (Fig.1) was already known by the ancient Egyptians.

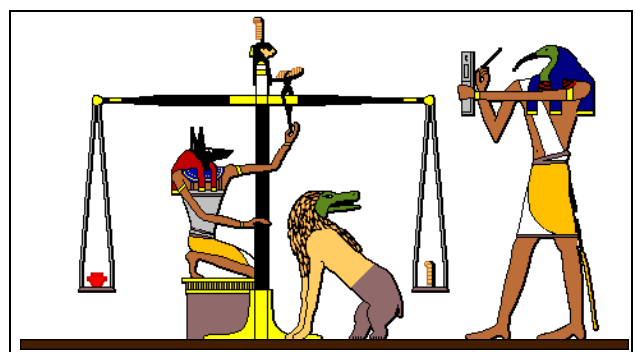

Figure 1. Egyptian equal-armed balance

This type of balance needs a precise set of increasing weights, which diffculted their transportation and their use was restricted mainly to closed places.

The development of an unequal armed balance seems to presuppose knowledge of the lever rule. The familiar steelyard or Roman

balance (Fig. 2) has a fixed fulcrum and a counterpoise weight moving along its arm. This balance needs only one counterpoise instead of a uniform set of weights. For this reason it could be easily carried.

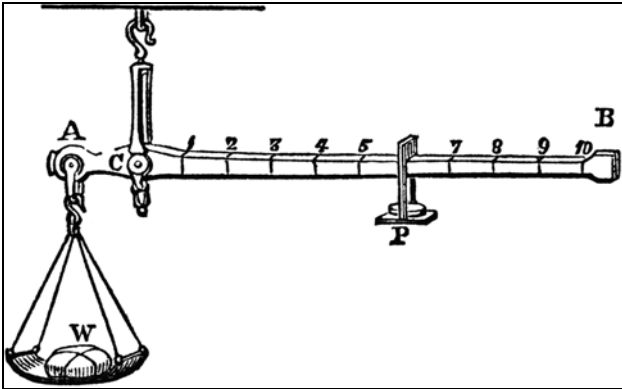

Figure 2. Roman unequal-armed balance

It was presumably the most widespread and frequently used mechanical precision instrument in antiquity and late antiquity [4], and it has also been the most common type of scales in China since the Han dynasty of the 2nd century BC [6].

## 2.2. Balances with mobile fulcrum

In this type of balance, known as the *bismar* in Medieval Europe (Fig. 3), the counterpoise weight is fixed, and balance was achieved by moving the fulcrum, which was normally a simple loop of chord [7].

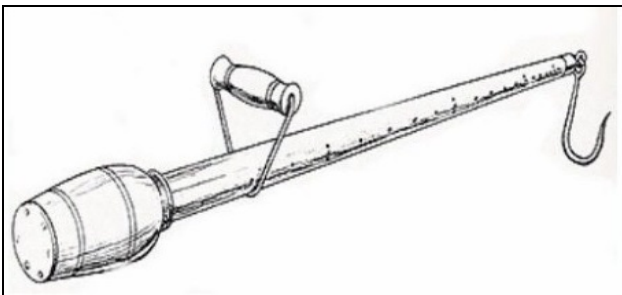

Figure 3. Bismar balance

The first mention in the Western world to this balance is in the Aristotelian *Mechanical Problems* (problem 20), which were probably written by Archytas of Tarentum [8]. The operation of this balance can be understood by the laws of the levers as stated by Archimedes. This is a static type of justification, where the fulcrum is placed at the equilibrium point between both masses [7].

Bismar balances had the advantage of their

simplicity of construction and use. In fact, any stick with a fixed weight on one end (such as tools like hoes or hammers, cookware like dippers or pans, or even weapons like spears or clubs) can be converted to a bismar balance by simply placing a hook at the other end [9].

We will use a qualitative rule which applies to these balances. It states that greater masses drag the fulcrum to them. In fact, an infinite mass would place the fulcrum directly at the hook.

## 2.3. Inclination balances

The idea of measuring weights by the inclination of the balance arm has been used to develop several types of inclination scales or pendulum scales, such as letter scales (Fig. 4), which can have a basis (to be placed on a table) or a ring (to be suspended from it).



Figure 4. Letter scales

Their operation is based on the concept of stable equilibrium, which can be achieved when the center of masses of a rigid system lies under its hanging point (this is how a pendulum operates).

We will resort, for didactic purposes, to devices that are not associated with the concept of a balance, such as for example a clothes hanger (Fig. 5) or any similar object.

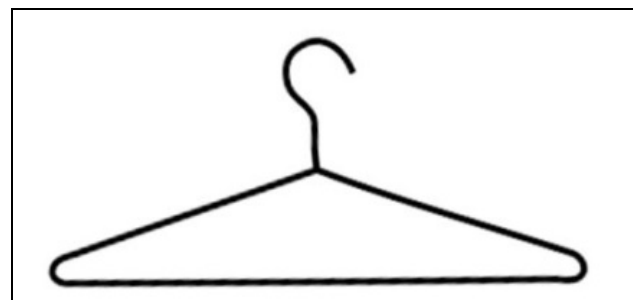

Figure 5. Clothes hanger

The hanger has a fixed point which is placed appreciably over the base line (the „stick“ of the imaginary balance). The fulcrum is not a

physical object, but the vertical projection of this hanging point to the stick. If the right mass is greater than the left one (Fig. 6), the hanger will be inclined to the right, thus displacing the fulcrum also to the right (where the greater mass is placed), which is what the qualitative rule stated at 2.3 predicts.

For small inclinations (or, equivalently, low mass inequalities) it is possible to establish a simple direct relation between mass and inclination.

The baseline (Fig. 7) has a length  $L$  and the height of the hanging point over the baseline is  $H$ . If we place two masses  $m$  and  $M$ , we can say that  $M = m(1+d)$ . The displacement of the fulcrum will have a value of  $x$ , and the length of the arms will be now equal to  $L/2+x$  and  $L/2-x$  respectively (Fig. 8).

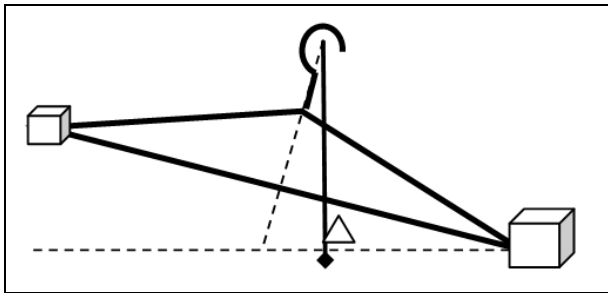

Figure 6. Hanger as a lever (unequal masses)

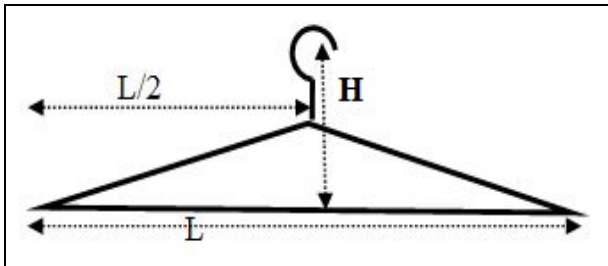

Figure 7. Hanger with special measures

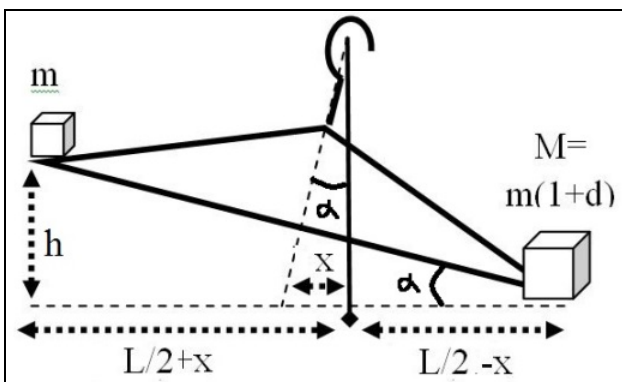

Figure 8. Law of the lever

The law of the lever states that  $m(L/2+x) = m(1+d)(L/2-x)$  (1)

$$L/2+x=L/2-x+dL/2-dx$$

$$(2+d)x=dL/2 \text{ and } x=(0.5*dL)/(2+d) \text{ (2)}$$

In the special case where the difference between  $M$  and  $m$  is low,  $d$  will be small compared to 2, and we get the approximate result

$$x= dL/4 \text{ (3)}$$

Comparing triangles we see that the vertical distance  $h$  between  $m$  and  $M$  due to the balance inclination can be expressed as

$$h=xLH^{-1}=0.25*dL^2H^{-1} \text{ or } d=4*HL^{-2}h \text{ (4)}$$

This would allow us to use the factor  $4*HL^{-2}$  to create a vertical scale and place it at the left side of the balance, where we could read directly the relative difference between both masses ( $d$ ).

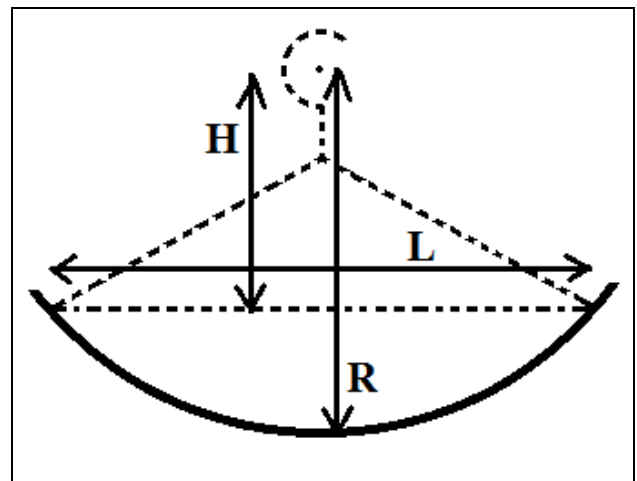

Figure 9. Arc of circumference in hanger

We can even replace the imaginary fulcrum by a real object. This object has to go by itself exactly to the equilibrium point, and this can be achieved by substituting the straight baseline of the hanger by an arc of a circumference, with radius  $R$  and chord  $L$  (Fig. 9).

A small ball rolling over this curved line (Fig. 10) would show the position of the fulcrum.

The curved base can even be used to hold up the system over a horizontal surface, in which case the hanger would not be necessary (Fig. 11).

If we want this baseline to stand by itself on a table, we should use a surface created by revolution of the curve around a central point (Fig. 12).

With a small ball moving freely on it, two masses can be compared if we place them on opposite borders of the dish. The system will be inclined in the direction of the greater mass (Fig. 14), and the displacement of the ball from the central point will be a measure of the ratio between both masses (neglecting the disk's mass).

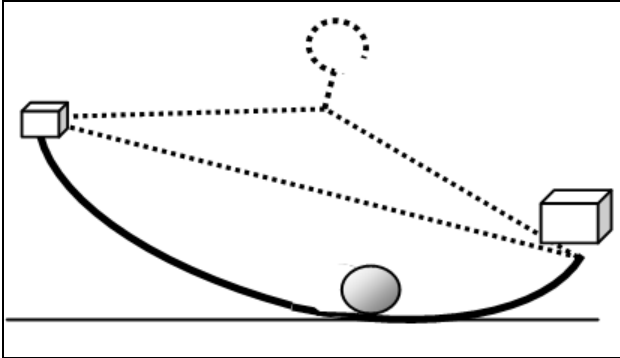

Figure 10. Ball showing the fulcrum

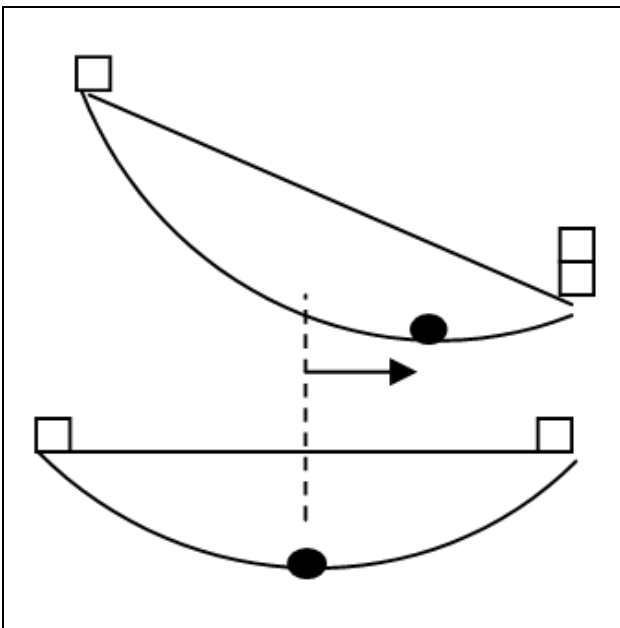

Figure 11. Curved lever without hanger

## 2.4. Spacetime balance: inelastic collision

It is possible to compare the masses of two colliding particles at the spacetime graph of an inelastic collision [3]. Placing space as the horizontal dimension and time as the vertical one, the collision of two masses with opposite velocities will be seen as a symmetric (isosceles) triangle (Fig. 15).

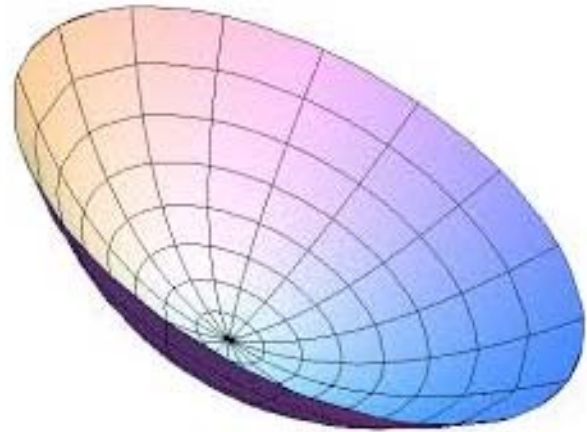

Figure 12. Surface of revolution

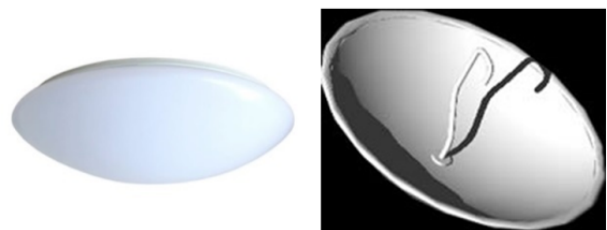

Figure 13. Wall light, satellite dish



Figure 14. Curved surface with rolling fulcrum

After the collision, both masses will follow the same path together (Fig. 16, wide black line). We can draw this line back in time (dashed line), and it will represent the center of masses at any given time (small triangle).

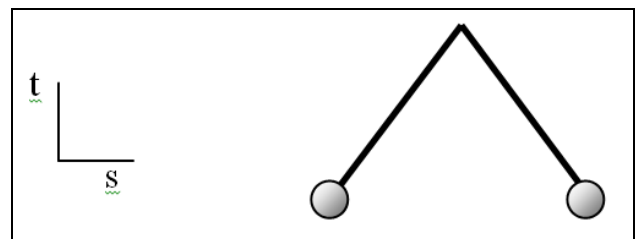

Figure 15. Symmetric collision in spacetime

We can add an imaginary rod, which is represented in the figures by a solid horizontal line joining both masses (Fig. 17). A horizontal line in spacetime can be interpreted as a „slice of reality“, where the measurement takes place.

The center of masses follows the law of the lever, and we can see that its position allows us



to compare the values of the masses (they are equal at the left figure, whilst at the right figure the mass at the right is greater than the mass at the left). If one of the masses is known, this comparison allows us to measure the mass of the other particle using the law of the lever, and we have a spacetime balance.

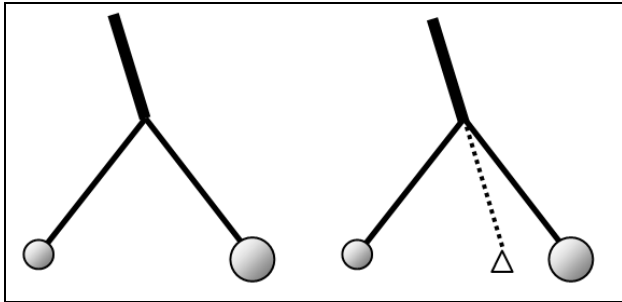

Figure 16. Center of masses and fulcrum

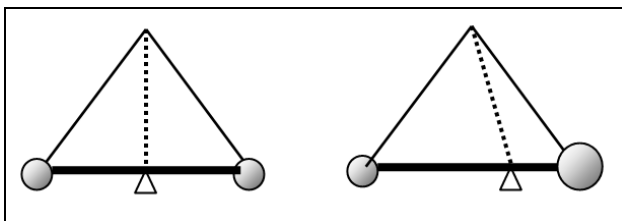

Figure 17

## 2.5. Energy: pendulum

In order to place mass and energy into the same diagram, we will resort to the pendulum, which had been studied already by Galileo, Huyguens and Newton as a tool to develop their mechanical ideas [10].

The ballistic pendulum is a device where a mass  $m$  collides at a speed  $v$  with a pendulum at rest, and the vertical deviation of both masses after the inelastic collision is used to establish the velocity  $v$  (Fig. 18).

In the previous figure we have made the assumption that the mass of the pendulum is negligible compared to  $m$ , and we have chosen units where  $m$ ,  $L$  and  $g$  are all equal to 1. This establishes automatically the unit of time as  $u_t = (L/g)^{1/2}$ . For example, if we have a pendulum with  $L = 1\text{m}$ , taking  $g=9.8\text{ m/s}^2$  as the unit of acceleration would render  $u_t = 0.32\text{ s}$ .

Under these circumstances, the energy conservation  $E_c = E_p$  and the laws for both energies ( $E_p = mgh$ ,  $E_c = 1/2mv^2$ ), as well as the geometric property  $h = 1/2x^2$ , (which is valid for small deviations  $x$  compared with  $L$ ) return the interesting result  $v = x$ . We have thus a way to

establish and measure the velocity  $v$  of the incoming bullet directly from the distance  $x$  travelled by the pendulum after the collision.

With the chosen units for  $m$  and  $g$ , we have also that  $E = h$ . This special pendulum, therefore, measures both energy and velocity (or equivalently, momentum, since  $p = mv = 1$ , because  $m = 1$ ).

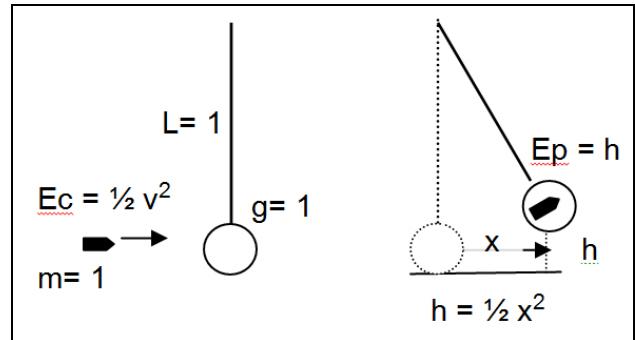

Figure 18

But  $L$  is also equal to 1, and thus the inclination of the pendulum from the vertical line will coincide with the velocity of the particle when represented in a spacetime diagram. This is an interesting way to connect spacetime with momentum/energy diagrams, as can be seen in Fig. 19.

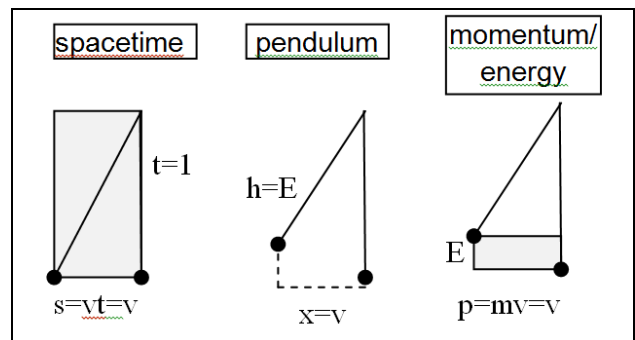

Figure 19. From spacetime to energy

These figures, although apparently very similar, are drawn in different spaces: the left figure is drawn in spacetime (and its lines represent the movement of the bullet and the pendulum at rest), the central figure is in „normal“ (two-dimensional) space (the lines represent the rods of two pendulums, the vertical being at rest and the inclined coming to collide with the same speed as the bullet), and the figure to the right is drawn in the new momentum/energy space (in this case, the lines are there only to compare with the other figures).

## 2.6. Mass, energy and relativity

After having established our spacetime balance, together with the geometric equivalence between spacetime and energy/momentum spaces, we can proceed to the following theoretical question, which Einstein already established as the title for one of its famous articles in 1905: »Ist die Trägheit eines Körpers von seinem Energieinhalt abhängig?« (Does the inertia of a body depend upon its energy-content?). This article [11] was the origin of the mass/energy equivalence relations, with the worldwide famous formula  $E=mc^2$ .

We will introduce mass and energy into our spacetime balance and look after their behaviour under a spacetime transformation. Uniform movements are represented as straight lines in spacetime, and any transformation between inertial reference systems must keep them straight. As a consequence, the transformations will have the property of being linear. The determinant of a linear transformation measures the rate of change in the surface area, and the determinant of two successive transformations is the product of their determinants (in particular, the determinant of the inverse transformation is the inverse of its determinant). The principle of space isotropy states that all spatial directions have the same properties. To obtain the inverse transformation of a given one, we must simply go in the opposite direction. As a consequence, the spacetime area must be conserved in inertial transformations (because otherwise it would change differently in one direction and in the opposite one, contradicting the isotropy principle). The conservation of spacetime area is a fundamental property of every relativistic transformation between reference systems, and we will use it as a geometric property of the spacetime transformations.

We will begin with a very symmetrical kind of inelastic collision, where two identical particles collide with opposite velocities. In this special situation, it is straightforward to verify that the center of mass, due to the symmetry of the figure, must stand at its center (Fig. 20, left side). This corresponds to the condition of both particles having the same mass.

If we view the same collision from the reference system of the mass coming from the

left (Fig. 20, right side), this means that its spacetime line will be vertical (any particle is at rest in its own reference system), whilst the other mass comes from the right with greater speed. Regarding energy, the left mass will have no kinetic energy, and the same is not true for the right mass. The symmetry of the situation is therefore broken, and we can now try to find an answer to Einstein's question in the following visual way: The right mass has energy, but the left one has no energy. Any change in the inertia of the right mass due to its energy content should be observed as a displacement of the centre of mass.

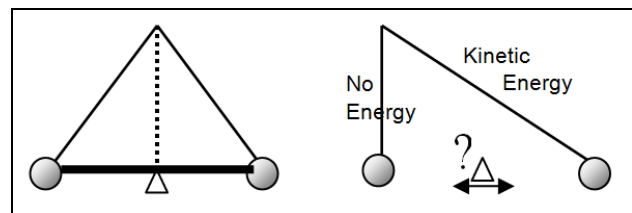

Figure 20. Einstein's question in spacetime

Classical relativity is based on the galilean transformation, which depends on the concept of a universal time. This means that the (horizontal) baseline of the figure remains unchanged (Fig. 21).

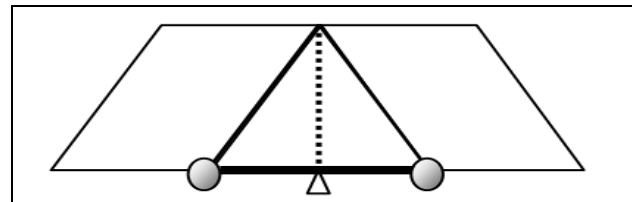

Figure 21. Classical symmetric collision

The centre of mass lies therefore always in the middle of both masses (Fig. 22), and the answer to Einstein's question from classical physics is clearly a negative one: The energy does not displace the centre of mass, because mass and energy are clearly different magnitudes and they cannot be added in classical physics.

We have drawn spacetime cells as lateral parallelograms for every particle to see more clearly the effect of the spacetime transformation. It is possible, for example, to recognize that the spacetime area of these cells remains constant during the transformations, since the area of a parallelogram is given by the product of its base by its height, and both remain unchanged.

## 2.7. Mass and energy in special relativity: equivalent magnitudes

Special relativity is based on the Lorentz transformation, where the horizontal baseline, due to the relative movement, gets an inclination which in natural units (where  $c = 1$ ) is equal to the inclination of the line of the particle with respect to the vertical.

It is possible to compare the effect of inclination on a square and a rhombus which derive from a given square of size 1, if both figures share a common side, which derives from an inclination of the square's side by a factor  $v$  (Fig. 23).

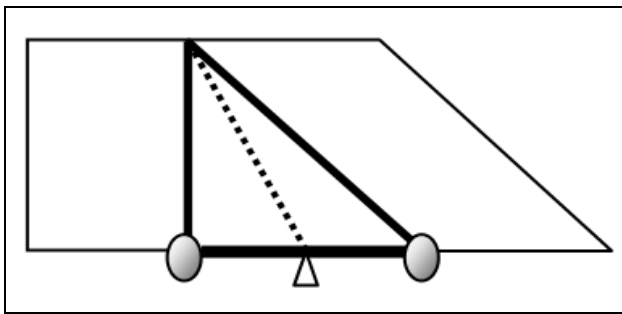

Figure 22. Galilean transformation

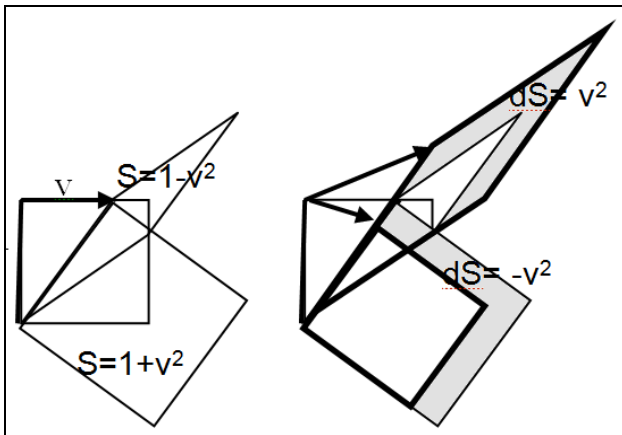

Figure 23. Inclined square and rhombus

The inclined square will have now a size greater than 1 ( $S=1+v^2$ ), and the rhombus' size will be smaller ( $S=1-v^2$ ).

If the size of these figures must keep its initial value of 1, we must compress the square and expand the rhombus. In both cases, the change in size is the same:  $v^2$ . For small values of  $v$ , this change in size can be viewed as the subtraction (for the inclined square) or addition (for the rhombus) of two strips with approximate length of 1 and width of  $v^2/2$  (grey shadows on the right side of Fig. 23).

In the general case, the square will describe a circumference, and the vertical contraction (Fig. 24) will be given by the cosine of the inclination angle. For the rhombus (Lorentz transformation), the line described is a equilateral hyperbola, and the vertical dilation is given by a hyperbolic cosine. The function  $\cosh v$ , for small values of  $v$ , can be approximated by  $1 + v^2/2$ , as we have seen.

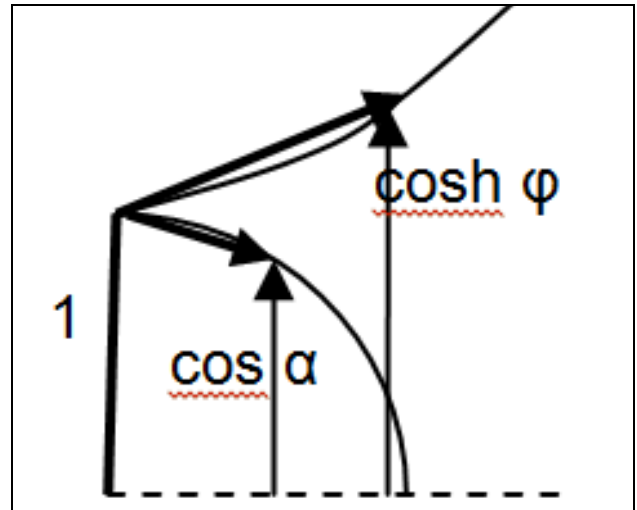

Figure 24. Circular and hyperbolic functions

As a consequence of this, the Lorentz transformation will show an enlargement on the vertical component of the timelike lines, which is called „time dilation“. The combined effects of time dilation and base inclination will create a new geometrical meaning for energy, as we will see. We will begin with the spacetime diagram of the symmetric collision with the spacetime cells (Fig. 25).

The change to the reference system of one of the masses is called a „boost“, and its geometric representation is a Lorentz transformation (Fig. 26).

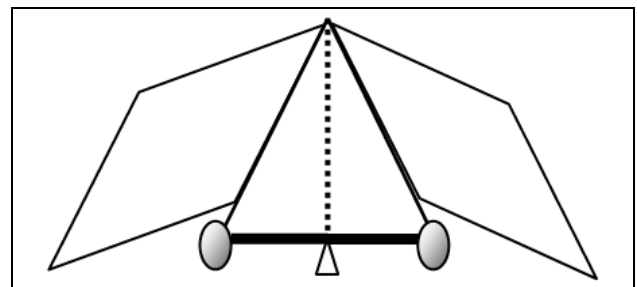

Figure 25. Relativistic symmetric collision

We can notice several differences between the classical case (Fig. 22) and the relativistic case (Fig. 26). The latter shows again the center of masses at the middle of the inclined

baseline (dashed line). But the spacetime balance must be constructed, as we have seen, with an (imaginary) horizontal rod, because reality is horizontal in spacetime. The position of the center of masses in this rod is no more in the middle of both masses, but it is displaced to the right. The situation is no more symmetric, and the mass coming from the right has a kinetic energy which the other mass lacks (it is at rest in its own reference frame). This dragging action of the energy on the center of masses is equivalent to an additional mass. In this case, the answer to Einstein's question is: „YES, the inertial properties of the mass have changed due to its energy“ [12].

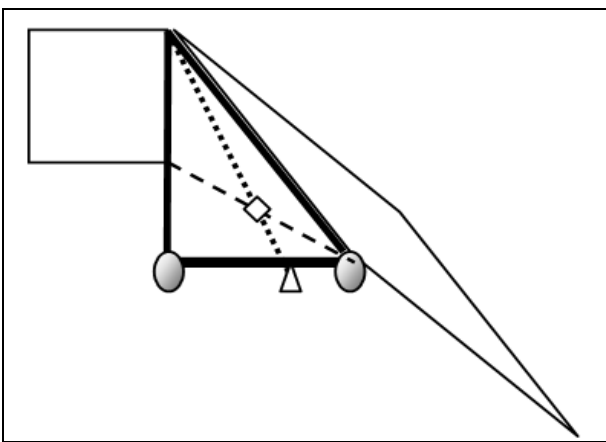

Figure 26. Symmetric collision after the boost

We can even try to quantify the magnitude of this effect (at least in the low-velocity case) using the relations we have seen earlier for the inclined levers. In section 2.4 equation 4 tells us that the vertical displacement  $h$  is proportional to the (relative) additional mass  $d$ , the proportionality factor depending on the measures of the balance. The spacetime diagram in Fig. 27 shows also that the energy is proportional to the vertical displacement  $h$ , which is in visual accordance with Fig 19 for the pendulum.

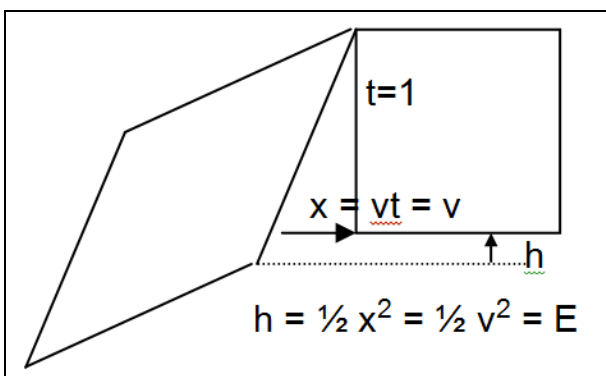

Figure 27. Spacetime collision with energies

All these relations give us a strong visual and intuitive support for the claim that energy displaces the center of mass in the same way as an additional mass would do. We are using natural units with  $c = 1$ , and Einstein's formula in these units looks much more unsurprising:

$$E = m$$

We have now the possibility to explain the most famous formula of modern physics in a visual way using levers and diagrams.

### 3. Electromagnetic effects with rods

The mutual force between parallel currents (known as Ampère's Law) can be explained as a consequence of the relativistic effect of length contraction when applied to the moving charges, and some textbooks already use this approach [13]. In the same way, we will show how the movement of a conductor stick, together with the relativistic effect of length contraction, are responsible for the creation of an induction current (Faraday-Lenz Law).

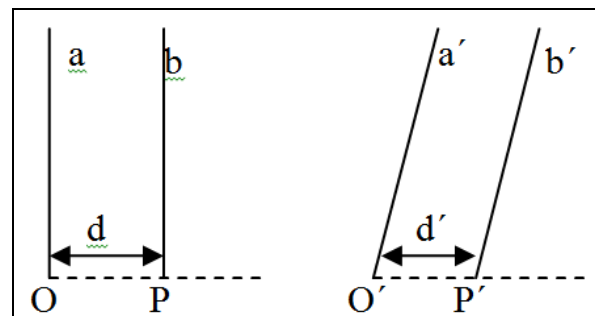

Figure 28. Length contraction

#### 3.1. Length contraction

The Lorentz transformation, when applied to a certain length which is parallel to the relative velocity, creates a relativistic effect which is known as the length contraction. We can view it as the (horizontal in spacetime) distance  $d$  between two parallel lines ( $a, b$ ) corresponding to two charged particles in relative rest. This is the distance  $d$  in Fig. 28 (left) between points  $O$  and  $P$  in their own reference system.

If the charges are moving all with the same speed  $v$  (Fig. 28, right side) then the new horizontal distance will be  $d' = d/\gamma$ . The factor  $1/\gamma$  is called the „length contraction factor“. It is always lower than 1, and in the low-speed limit (as shown in section 2.7) it can be approximated by



$$\gamma^{-1} = 1 - 0.5v^2 \quad (5)$$

### 3.2. Line current I

We will use a very simple model for a line current. It consists of two sets of particles with identical positive and negative charges, which are uniformly spaced over a very long straight line where they move with constant opposite velocities. A charge density  $\lambda_0$  is defined dividing the individual charges by their separation. The positive charges will have a density  $\lambda_+ = \lambda_0$  whilst the negative charges show a density  $\lambda_- = -\lambda_0$ .

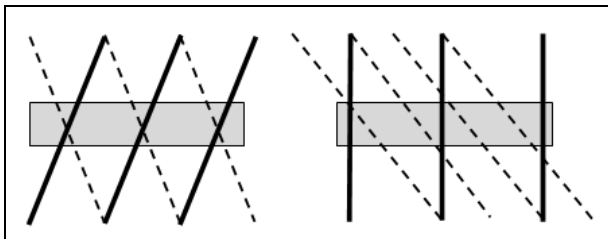

Figure 29. Current and boost

The total (net) charge density is obtained as  $\lambda = \lambda_+ + \lambda_- = \lambda_0 - \lambda_0 = 0$ . This means that for an outside observer the line current appears to have no net charge at all.

The positive and negative charges move with opposite velocities  $v_+ = v$  and  $v_- = -v$ . These movements produce two currents:

$I_+ = v_+ \lambda_+ = v\lambda_0$  for the positive charges, and  $I_- = v_- \lambda_- = (-v)(-\lambda) = v\lambda_0$  for the negative charges. There will be a net current as a result of both opposite movements:

$$I = I_+ + I_- = 2v\lambda_0 \quad (6)$$

### 3.3. Ampère Law

If we place two line currents  $I_1$  and  $I_2$  parallel to each other at a distance  $r$ , the experimental evidence obtained by Ampère states that they feel a mutual force which is attractive if both currents flow in the same direction, and repulsive if their directions are opposite. The force by unit of length  $F/L$  is given by

$$F/L = \mu_0 I_1 I_2 / 2\pi r \quad (7)$$

It is possible to explain this force as a result of the relativistic effect of length contraction.

In natural units, where the speed of light is equal to 1 ( $c=1$ ), the relation between the magnetic and electric constants  $\mu_0$  and  $\epsilon_0$ ,

$\mu_0 \cdot \epsilon_0 = 1/c^2 = 1$  implies that  $\mu_0 = 1/\epsilon_0$ . We define the intensities  $I_1 = 2v\lambda_1$  and  $I_2 = 2v\lambda_2$ . With these units and definitions, the force obtained experimentally by Ampère can be expressed as

$$F/L = 4v^2 \lambda_1 \lambda_2 / 2\pi \epsilon_0 r \quad (8)$$

In Fig. 29 (left) we can see the model of line current in a spacetime diagram. The positive charges (solid lines) go to the right and the negative charges (dashed lines) flow to the left. They are equally spaced, so that the net charge is zero (we can count 3 positive and 3 negative charges in the horizontal slice of spacetime).

At the right, we see the same current as observed from the reference system of the positive charges in the second conductor. This corresponds to a boost that places the positive charges at rest, while the negative charges have greater speed to the left. The length contraction applies in this case to the negative charges, and they are more tightly spaced (we can count 4 negative charges but only 3 positive charges in the spacetime slice). There is now an excess of negative charge in conductor 1, and since the reference system corresponds to the positive charges of the second conductor, they will feel an attraction, as was observed by Ampère.

To quantify this effect, we should notice that the negative charges (in the low speed approximation) will have a velocity  $2v$ , and the length contraction (Eq. 5) will have a value of

$$\gamma^{-1} = 1 - 2v^2 \quad (9)$$

The charge density is inverse to the distance between charges, and the inverse of  $1 - 2v^2$ , in this approximation, can be taken as being  $1 + 2v^2$ . Therefore, if the density of the positive charges in the first conductor is  $\lambda_+ = \lambda_1$ , the negative charges will have a greater density:  $\lambda_- = -\lambda_1 (1 + 2v^2)$ . The total charge density has now a nonzero value:

$$\lambda = \lambda_+ + \lambda_- = \lambda_1 - \lambda_1 (1 + 2v^2) = -2\lambda_1 v^2 \quad (10)$$

The first conductor is felt therefore (by the positive charges of the second one) as a charged rod with a negative density  $-2\lambda_1 v^2$ . This produces an electric field with a value of

$$E=2v^2\lambda_1/2\pi\epsilon_0r \quad (11)$$

A segment of length L from the second conductor, whose charge density is  $\lambda_2$ , will have a total positive charge  $q=L\lambda_2$ , and it will be attracted by the first conductor with a force

$$F_+=qE=2v^2\lambda_1\lambda_2/2\pi\epsilon_0r \quad (12)$$

The negative charges from the second conductor, in their own reference system, will see the negative charges in conductor 1 at rest, and the positive charges in movement, so that they will be contracted. There will be an excess of positive charges, which will exert an attractive force F. with the same value as  $F_+$ . The segment of length L from the second conductor will thus feel a total attraction with a value of

$$F=2F_+=4Lv^2\lambda_1\lambda_2/2\pi\epsilon_0r \quad (13)$$

Which corresponds exactly with Ampère's Law as written in Eq. (9).

### 3.4. Electromagnets

The possibility of explaining Ampère's Law as a direct consequence from the relativistic effect of length contraction opens the gate for the introduction of magnetic effects as a sensible evidence in favor of relativity in earlier courses.

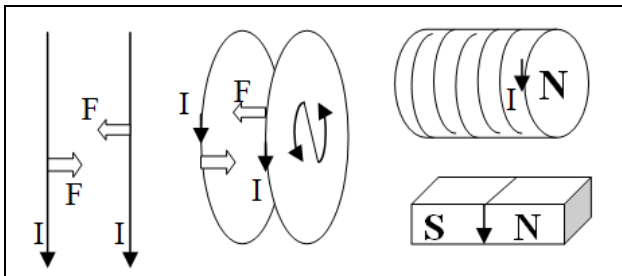

Figure 30. From currents to magnets

To understand the operation of magnets and magnetic motors, we can simply resort to the pair of attracting parallel currents, and turn them around to form circles, which will also attract one another. A collection of such circular currents is a solenoid, and a magnet can be substituted by a solenoid with the appropriate orientation (Fig.30).

Magnetic effects can be very impressive and diverse, and they can be presented in any laboratory from the most simple case of a self-made electromagnet to more complex ones, such as electric motors (Fig. 31).

As we have seen, all these phenomena can be explained very intuitively using only the attractive or repulsive forces between parallel currents, which ultimately derive (even quantitatively) from the relativistic effect of length contraction.

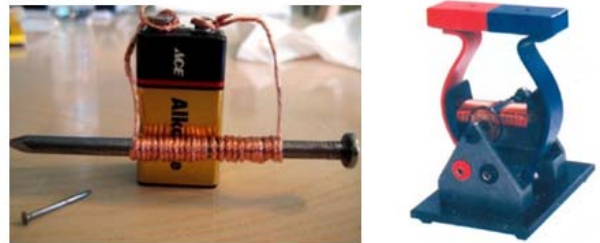

Figure 31. Electromagnet and electric motor

### 3.5. Plane current K

It is also possible to explain the generation of electric currents by induction resorting only to relativistic effects. We will focus here on the special case of an uniform and static magnetic field. This can be ideally achieved by an unlimited planar sheet of current, which can be also viewed as an infinite set of parallel line currents lying on a plane. If the intensity of every line current has a value of I and there are N lines per unit of width, the plane current is defined as  $K = NI$ .

The magnetic field created by this plane current has a value

$$B = \mu_0IN/2 = \mu_0K/2, \quad (14)$$

which is uniform and does not depend on the distance from the sheet of current.

We can model a plane current in the same way as we did in section 3.2 for linear currents. We consider now that the plane current is made up of two uniform plane sheets of opposite charges moving with opposite velocities. Defining the surface density of charges as  $\sigma_0$ , we will have two charge densities  $\sigma_+ = \sigma_0$  and  $\sigma_- = -\sigma_0$  which cancel mutually to produce a total charge density  $\sigma=0$ .

Positive and negative charges move again with opposite velocities  $v_+ = v$  and  $v_- = -v$ , producing two plane currents  $K_+ = v_+ \sigma_+ = v\sigma_0$  and  $K_- = v_- \sigma_- = v\sigma_0$ . As a result of both opposite movements there will be a net current:

$$K = K_+ + K_- = 2v\sigma_0 \quad (15)$$

### 3.6. Induction (Faraday Law)

If a conductor of length  $L$  lies perpendicular to a uniform magnetic field  $B$  and is forced to move with a velocity  $v_2$  which is perpendicular both to the field and the conductor, an electromotive force (emf)  $\mathcal{E}$  is generated with a value of  $\mathcal{E} = BvL$  (Fig. 32).

This is a consequence of Faraday's Law, and it is also in accordance with Lenz's Law  $\mathcal{E} = -d\Phi/dt$ , where  $\Phi$  is the magnetic flux over a closed surface  $\mathbf{S}$  ( $\Phi = \mathbf{B} \cdot \mathbf{S}$ ) and the minus sign indicates that the induced current is opposed to the change in magnetic flux.

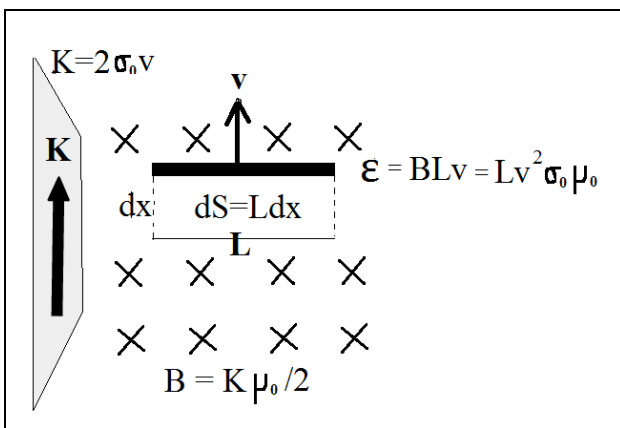

Figure 32. Sheet of current and emf

To show the identity of both expressions, we recall that the magnetic field  $B$  is perpendicular to the surface  $S$ . As a result, the magnetic flux will be given by  $\Phi = BS$ , and its time derivative  $d\Phi/dt = SdB/dt + BdS/dt$ . We consider the case where  $B$  is constant, so  $d\Phi/dt = BdS/dt$ . The conductor sweeps a surface  $dS = Ldx$  with a velocity  $v_2 = dx/dt$ , and thus  $dS/dt = Lv$ , which immediately renders the desired result:

$$d\Phi/dt = BdS/dt = BLv. \quad (16)$$

An electromotive force  $\mathcal{E}$  on a conductor of length  $L$  can be seen also as the result of a uniform electric field  $E$  pointing alongside  $L$ . The relation is  $\mathcal{E} = LE$ , or  $E = \mathcal{E}/L$ . (17)

Equations (14) to (17), together with  $\mu_0 = 1/\epsilon_0$ , give the following expression for the field  $E$ :

$$E = \mathcal{E}/L = Bv = \mu_0 K v / 2 = v^2 \sigma_0 / \epsilon_0 \quad (18)$$

We will try to justify equation (18) as a result of the relativistic length contraction when applied to the negative charges (Fig. 33).

We make the assumption that the rod

moves with the same speed  $v$  as the current charges (we could always assure this by adjusting the surface density accordingly). Then, from the rod's reference system, the positive charges would be at rest and the negative charges would move with a speed  $2v$ . The same as in (10), if the density of the positive charges in the current sheet is  $\sigma_+ = \sigma_0$ , the negative charges will have a greater density:  $\sigma_- = -\sigma_0(1+2v^2)$ . The total surface charge density has now a nonzero value:

$$\sigma = \sigma_+ + \sigma_- = \sigma_0 - \sigma_0(1+2v^2) = -2\sigma_0 v^2 \quad (19)$$

The electric field due to a plane charged with a surface density  $\sigma$  is  $E = \sigma / 2\epsilon_0$ , which using (19) gives  $E = \sigma_0 v^2 / \epsilon_0$  which is identical to the desired expression (18).

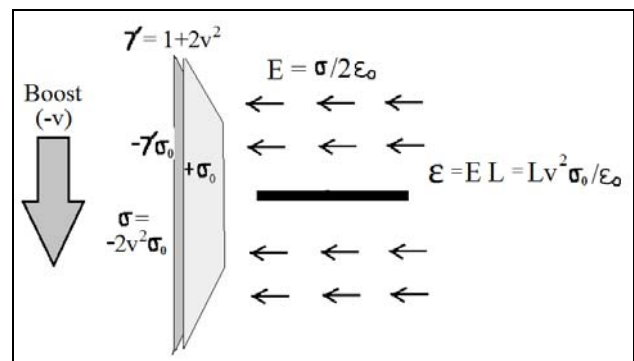

Figure 33. Boost and resulting electric field

### 3.7. Electricity production

Electromotive forces (or induction currents) are responsible for the production of electricity in almost every generator. In this way, it is possible to state that relativity is the ultimate cause that allows artificial electricity to exist. This can be very easily illustrated at any elemental laboratory using a didactic dynamo or alternator, as well as with a bicycle lamp (Fig. 34).

The relativistic explanation for the induction of electromotive forces, as well as for magnets and motors, has two great advantages from a didactic point of view: It is conceptually simple, and at the same time it makes relativity a plausible and real phenomenon, not of an esoteric nature, but related instead to the very foundations of our highly techified societies. The fact that the same effect of length contraction can be used to explain a broad scope of electromagnetic effects as well as the equivalence between mass and energy, is an additional advantage of this innovative didactic

approach. Its visual essence, derived from the fact that relativity is embedded in the geometry of spacetime, adds even more interest to it from a constructivist viewpoint.

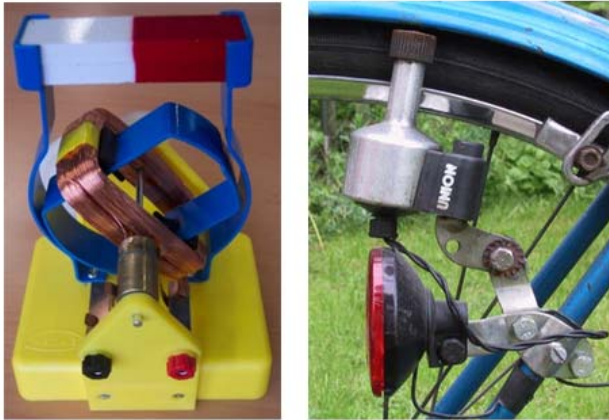

Figure 34. Didactic and bicycle dynamos

## References

- [1] Prado X. Visual Relativity (Interdisciplinary Didactic Unit); 2000. [https://sites.google.com/site/hansonrelativity/home/physics\\_on\\_stage\\_cern2000](https://sites.google.com/site/hansonrelativity/home/physics_on_stage_cern2000) [visited 16-May-2015].
  - [2] Prado X, Dominguez JM. A didactic proposal for the visual teaching of the theory of relativity in high school first course. In Tasar MF, Çakmakci G, editors. Contemporary Science Education Research: Teaching 2010 (proceedings of ESERA 2009 Conference) p. 297-305.
  - [3] Prado X, Domínguez JM. Audiovisual Animations for Teaching the Theory of Special Relativity Based on the Geometric Formulation of Minkowski. In: Hands-on Science. Science Education with and for Society. Costa MFM, Pombo P, Dorrió BV (Eds.), Hands-on Science Network; 2014, p 259-266.
  - [4] Büttner J. Between Knowledge and Innovation: The Unequal-Armed Balance. <http://www.mpiwg-berlin.mpg.de/en/research/projects/RGBuetner> [visited 16-May-2015].
  - [5] Renn J, Damerwo P. and McLaughlin P. Aristotle, Archimedes, Euclid, and the Origin of Mechanics: The Perspective of Historical Epistemology. Max-Planck Institute for the History of Science, available at [http://www.philosophie.uni-hd.de/imperia/md/content/fakultaeten/phil/p\\_hilosophischesseminar2/mclaughlin/mcl6.pdf](http://www.philosophie.uni-hd.de/imperia/md/content/fakultaeten/phil/p_hilosophischesseminar2/mclaughlin/mcl6.pdf) [visited 16-May-2015].
  - [6] Cotterell B, Kamminga J. Mechanics of Pre-Industrial Technology. Cambridge: Press Syndicate of the University of Cambridge; 1992, p. 85-86.
  - [7] Kisch B. (1965). Scales and weights: a historical outline. New Haven and London: Yale University Press. pp. 56-66.
  - [8] Winter TN. The Mechanical Problems in the Corpus of Aristotle, (2007). Faculty Publications, Classics and Religious Studies Department. Paper 68. University of Nebraska-Lincoln. Downloadable at: <http://digitalcommons.unl.edu/classicsfacpub/68> [visited 16-May-2015].
  - [9] Damerow P, Renn J, Rieger S, Weinig P. Mechanical Knowledge and Pompeian Balance. Preprinted 200 at the Pax-Planck Institute for the History of Science, Berlin. Available at <https://www.mpiwg-berlin.mpg.de/Preprints/P145.PDF> [visited 16-May-2015]
  - [10] Solaz J, Sanjosé V. El Papel del Péndulo en la Construcción del Paradigma Newtoniano. Enseñanza de las Ciencias 1992, 10(1): 95-100.
  - [11] Einstein A. Ist die Trägheit eines Körpers von seinem Energieinhalt abhängig? Annalen der Physik 1905, 17: 891-893.
  - [12] Prado X et al (in preparation).
  - [13] Purcell EM, Morin DJ. Electricity and Magnetism. Cambridge: Cambridge University Press; 2013.
- 
-

## Students Become Mathematics Teachers

*L Sousa*  
*MADEIRA Multilingual School,*  
*Escola da APEL, Portugal*  
*liliana.math@gmail.com*

**Abstract.** The key purpose of this paper is to make a didactic proposal that tries to overcome the prejudices among students against Mathematics by providing them with the opportunity to connect the subject not only with their school work but also with their personal interests from a hands-on perspective. All the projects based in an entrepreneurship education that portrays motivation as key.

**Keywords.** Entrepreneurship, Mathematics, Motivation.

### 1. Introduction

This good practices paper is based upon my personal experiences from three different points of view. Firstly, as a student that always looked forward to participate in entrepreneurship programs. Secondly, as a trainee teacher at Escola da APEL where I had the privilege of working and learning with all the members of the school community that demonstrated the utmost commitment to an effective education. Last but not least, as a MYP Mathematics teacher at MADEIRA Multilingual School, which was an opportunity to my professional development, as a result of exploring The International Baccalaureate philosophy and also implementing my prior learning on the Portuguese curriculum.

Trying to understand how to best prepare the students for a future that will definitely look radically different not only from the school environment but also from present, reveals the significance of developing transversal skills. The mission of the teacher is to instigate the natural curiosity and logical questioning to students, as well as encourage their search for knowledge. Equally important is to make them realize that error is a step of the process and, thus encourage them to take risks. In order to do so, students will have to be open-minded thinkers that embrace whatever comes from the outside and make creative changes to find a reasonable goal.

Taking into account that Mathematics is considered to be the key tool for logical thinking, a holistic Mathematic education that fosters the development of critical thinkers and proactive citizens cannot leave aside other areas of knowledge. Therefore, it directly implies its connection with entrepreneurship as it provides the students with the essential attributes to become true entrepreneurs.

Motivation is the input for achievement, it is the first step to be well succeeded in a subject, in school, and consequently in life. Embracing the true spirit of mathematics and creating the right environment will determine the way students work before, throughout, and after discovering this universal language. In this matter, it is important to understand the students' perceptions of the use of Mathematics, and consider what role creativity plays in forming these perceptions.

To improve this ability, the teacher has the duty to emphasize the relationship between affective and cognitive experience. This means that the students not only should be introduced to an interesting activity but also be given the freedom of choice regarding the matter. For instance, in my experience with the MYP3 students, I had to deal with one particular student whose dismay for Mathematics prevented her from learning. Hence by combining a real life scenario, in this case her passion for horsemanship, with Mathematics helped her understand the usefulness of this subject in life.

All things considered, it relies on the teacher the commitment of becoming a learner, focused on the strengths of the students as individuals and their personal interests, rather than applying conventional methods that, not only do not benefit the group work, but also do not have the suitable prior learning.

In short, students are responsible for choosing the movie and are invited to look for the Mathematics behind the scenes. This subject should be a journey of enlightenment where both students and teachers are long life learners.

### 2. Education System, teachers and students.

We live in a demanding world that expects us to be prepared not only to respond to

multiple situations as well as to analyse them from different perspectives. The complexity of living in the 21st-century lies in the fact that we are into an hyper-connected culture, with more people and fewer resources which evokes to a hectic and competitive world full of uncertainties. A society which features a workforce that is further mobile and better qualified than ever before, which is also ready to embrace careers that engage multiple jobs, positions and skills sets.

To be able to succeed in that matter and overcome the impacts of globalization, we as individuals must develop the skills and consequently the needed attributes throughout our lives. Considering that, at an early stage we are shipped into an educational system in which we become the produced images of those who have the mission of developing the inherent philosophy and the underlying program.

Undoubtedly, families and caregivers do not have the resources or(and) training to support their children' academic success and in some situations their social development is left mostly in the hands of the education experts. Therefore, it is the educational system that has the responsibility to guarantee that students are not only equally prepared to engage a professional life, but also to make a positive enrichment to their community.

In our society, we can observe that students are maturing in different ways, instead of achieving the same qualities to survive in the world that seeks out innovation.

Despite all the reformers advocating change, this line of reasoning highlights the brittleness of the standardized educational system and its professionals.

Thus, this brings us to two questions. First, what is happening to our educational system, and what are the aims towards the attributes that our students are achieving? Further, are we just performing, or are we doing an effective teaching?

One cause for the inefficiency of our educational system remains to the governing culture that, instead of focusing their aims on the teaching and learning are centering intentions on the testing. Assessment is necessary, and standardized tests and exams

are one of the ways to observe and quantify the students' contents achievement and present statistical answers to society. The problem is that the dominant culture of education rather than using the results as a diagnostic to support learning, it is generalizing our students' abilities on those results, and it is restraining their development.

As a human system, education should be not compared to an industrial process, built on automatic conjectures that can be enhanced just by providing better data. It is a utopian assumption to think that we will accomplish the flawless guideline and that it will have an endless use. It should be taken into account that our students are not standardized people. It is precisely due to the essence of the human being that each student has a particular way to interpret and to react, especially when they have to face a standardized educational program.

Nonetheless, our education system is engulfed in the thought of academic ability, due to the industrialism. However, having a degree does not assure that you will be able to have a job. Therefore, another cause of the inadequacy of our system concerns the core of subjects that are considered essential for the students' success.

As we can see, not all of our students know precisely, what their visions for the future are. Unfortunately, our students are obligated to choose a particular area of knowledge which presents a restricted group of subjects instead of having a broad and balanced core. Moreover, they are discouraged to do subjects they like based on the idea that they would never get a job in such area.

The Portuguese Ministry of Education states in the Portuguese Curriculum what are the expected attributes for a student to achieve throughout their process of education. However, the decisions and the adopted action plans lead the community to interpret different aims. Likewise, until I was a trainee teacher when I had the opportunity to analyze the Portuguese Curriculum document, I envisioned that the purposes of the educational system were based on contents and not on transversal abilities.

Finding in the Portuguese Curriculum document, that education government state



their goals on skills, combining both global and explicit skills [1] made us wonder why patterned assessments will report the achievement of the students.

The striking fact on this issue is that the Portuguese system portrays a fever for the national exams and its final results. Indeed, focusing on the university entrance, which is a protracted process, has come to a point, where it is bringing consequences into our students' development. The main problem is that the students after succeeding (or not) in standardized subjects, think they are not high talented, brilliant, and creative. Also, due to the belief that errors are fatal, they become frightened people, incapable of taking risks and consequently lead them to failure.

Carried to its logical conclusion, this line of reasoning means that the Portuguese educational system is, in fact, a contradictory system. On the one hand, the Portuguese Ministry of Education states in the Portuguese Curriculum what are the expected attributes for a student to achieve throughout their process of education. On the other hand, the adopted decisions and action plans lead the community to interpret different aims.

The effectiveness of an educational program is the strength of those who implement the actions and guide the students throughout their development. Included in this process, are all the professionals that set education as a goal. Notwithstanding, we teachers are held as the primarily responsible for the students' success.

Due to the technological progression our students are linked with people that are thousands of miles away as if there were in the in the same environment. They are consuming, reducing and communicating information through unimagined channels, which means that teachers are no longer the unique source of information. Howbeit, there can be no doubt that we are vital when validating, synthesizing relating and transforming the amount of available information into a problem-solving action.

One of the outcomes of this current culture has been the understatement of the importance of teachers. We have been persuaded to direct our teaching in order to prepare our students to standardized exams, each one related to a certain area of knowledge. Owing to that fact,

we have been encouraged to carry out routine algorithms rather than following our beliefs that would contribute decreasingly to the lack of connection between the educational environment and the real-life context.

As might be expected, this erroneous idea about the role of the teacher, evoked the discrediting of its figure by all the community. Wherefore, it has resulted in the discouragement of our category because we are forced to work against the system that does not support us when teachers are the carriers of the success of schools.

All this leads us to the need for change. We need an entrepreneurial education that flourishes all the capacities of the students and allows us and supports us, teachers, to go beyond the imaginable and provide our students an enhanced learning process.

Nowadays the word entrepreneurship has entered into our lives. The world seeks for entrepreneurs, people who are creative, innovative, natural or nurtured leaders. Those that are thinkers and inquirers, who explore opportunities and with a sharp focus on control and unlimited force take the risk and turn problems into successful ventures. A unique human being that is a passionate, unstoppable learner that assumes failure as a step in the process. An individual independent and self-sufficient that is able to work in a team and puts his best effort to transform and to create a thriving culture. Unquestionably, a real person that combines all these layers and sets apart from their peers.

There are people who infer that entrepreneurs are born and not made, and there are people who share the opposite idea. A real entrepreneur is one who understands that achieving such abilities is a perpetual process, and that is inwardly related with the education process of learning.[2] All the experience is taken into consideration. The gains through education are vital to a future success.

Before wondering about if the students are becoming entrepreneurs, the teachers should ask themselves if they truly believe and live throughout their believing in that matter.

Taking into consideration that the "experience is what gives meaning to

language" [3] an effective teaching is a road, to an education of revolution. By that, to nurture the entrepreneurial spirit into our students, we have to be entrepreneurs.

Day after day, we face people who do want to learn or do not wish to hear, even students who want to or drops out the school. In my point of view, there is a reasonable explanation for it, which quintessence is in our personal biography. Besides the external influence of their peers, our students might find that what they are learning is wearisome; they might see it as unnecessary, they might not find any connection with their life outside school.

When I had the chance to learn with Professora Doutora Elsa Fernandes, I was able to look to the teaching profession from a different perspective. As a trainee teacher at my secondary school Escola da Apel and with the help of my guiding teacher Professor Cátia Belim, I was able to test and then analyse pedagogic ideas and strategies. Those two stages in the process of becoming a Mathematics teacher made me envision the extended work of a teacher.

When the students are not learning the teacher is engaging the task of teaching but not fulfilling it. Understanding how the students learn may be the first step in rectifying the learning process. But understanding what kind of teachers we have become and what make us be as we are, will make us improve ourselves and consequently the teaching methods we use in an open-minded perspective.

Based on my personal experiences throughout this learning process, I have found in Mathematics the perfect solution to develop a citizen that would succeed in supporting the concepts of entrepreneurship.

Mathematics is a universal language and it is a powerful tool to any area of knowledge because it provides a concise and unambiguous means of communication, and it gives means to explain and predict. Moreover, it develops logical thinking; it inspires curiosity and creativity due to its aesthetic appeal. It is also an art because it speaks to parts of students being that are untouched.

There is a negative image upon Mathematics, and some of our students do not

find its beauty and its use. The way we choose to develop the concepts inside (outside) the classroom has a remarkable input on the process of learning of our students. We can light the spark of curiosity in a student, and they will start learning because children are natural learners, and curiosity is the engine of achievement.

Teaching Mathematics is a challenging and creative profession. Definitely, besides passing on received information, the role of the teacher is to mentor, stimulate, provoke and engage.

When we teach only for calculating competence, we get demands for understanding. When we teach only for understanding, we get demands for calculating competence. We have to find the balance for both at once. It is through both competences that our students are "equipped" to solve real problems. However, to solve real problems, they need to understand Mathematics and paradoxically to understand Mathematics they need to explore real problems. Furthermore, when our students are learning Mathematics, they need to play with real objects and explore real problems that interest them.

In order to select and establish a connection with the real world we all seek for strategies, but we should be looking, or we should be listening. This question popped into my mind the first day I was invited to work at MADEIRA Multilingual School, a candidate school to the International Baccalaureate program. It was my first year teaching and I was in a brand new world, a new experience, an unknown educational system, with a broad approach:

*"The aim of all IB programmes is to develop internationally minded people who, recognizing their common humanity and shared guardianship of the planet, help to create a better and more peaceful world."* [4]

After reading the first sentence of the IB learner profile, I thought about how, through my classes, was going to develop my students to become people with that specific characteristics.

I went to the classroom with an open-minded spirit, and I listened. Once listening for about one hour, I had multiples ideas about how I was going to make them flourish.



Listening to our students likes and dislikes, their doubts throughout their learning process, and their perception about their future makes us get to know what we will find during our journey. If the students are in trouble, then we have the chance to help them, starting by understanding the problem and then finding and supporting in whatever area they need.

Students try to find solutions to their real-life problems, through a feverish process of imagining multiple alternatives and possibilities. Is it not Mathematics a strength that could help those students in such a matter? Is it not an approximation to reality what we teachers should be looking for, to bring motivation into our classes?

Understanding that teaching Mathematics means using a broad approach, and taking into account the disturbed conception about Mathematics, I set aims on creativity and motivation. To achieve those purposes, would mean that each of my students would be able to see and affirm that Maths is everywhere.

I truly believe that learning can happen anywhere and everywhere. Taking the students outside their classroom is one of the best things that we can do to enlighten them about Mathematics. This results in a holistic experience, where students introduce Mathematics concepts from a hands-on perspective.

Piaget says that thinking and learning involve taking the environment apart, physically and mentally, and reconstructing it.[5] Mathematics, more than most of other subjects, comprehend an extensive hierarchy of concepts. By living Mathematics, students are deconstructing abstract concepts into a language that both teacher and students learn, which will allow them learn all the subsidiaries concepts until they form a particular one.

In my opinion, programs that involve students outside as well as inside the school always benefit the entire school environment. A classroom should be an open space, for students and teachers work together. However, learning should not be blocked by walls, it should happen when and where we want to learn. It should happen in classrooms, in schools, in our surroundings. Students should be the ones saying what, when and how they want to learn. The teacher should not be afraid to support

their ideas when they are reasonable and guide the students throughout their journey of enlightenment.

### **3. What happens? Maths happens!**

Through the year, I had the opportunity to work with four different classes and in all of them I have found different levels of knowledge and motivation. One that has taken my attention was MYP 3. The reason why I will stand out the work of this class is because there are students with amazing abilities, who are inquirers, caring and risk-takers. However, they had a dreadful idea about Mathematics.

All kids have tremendous talents, and words have the power to change the meaning, the mood, and the motivation. So, as soon as I got to know them, and they got to know me, they have shown that they wanted to learn no matter what. Also, they were ready to engage any task with an open-minded spirit.

We have worked in different activities inside and outside our school doors. All of them were named by the students, regarding their creative side.

Based on the concept Maths is Everywhere, we started with "*Maths under the Christmas Tree*", an inside classroom and then outside project where they worked with MYP 4 students. The objective was to decorate, with platonic solids, our Christmas tree for the Carol Concert at Vida Mar Auditorium, as you can see in Fig.1.



**Figure 1. MADEIRA Multilingual School Christmas Carol Concert Tree**

The students had to investigate the properties of those solids to construct them, and finally decorate their final work with the colours of the school. With this project, they were able to explore many concepts within multiple topics of geometry and also develop their research, thinking and social skills.

This idea was set in one project that I had developed the previous year as a trainee teacher, where the students had to build and decorate platonic solids for a Christmas geometry exhibition and contest.

As a second project, we had *"Maths in a cereal box"*. That was an outside activity in which students had to go to Supermercado Regional, which is next to our school. The objective was to go shopping for snacks and to find the best shape and size product to save money at the supermarket.



Figure 2. Different size cans

The students had to identify similar products in different packages, calculate the volume and then they had to relate the results with the concept of capacity. We can see in Fig. 2 one of the products that they have compared. After that they discussed prices by verifying how much it cost the same percentage of product and to be able to buy more for less. To conclude this task we talked about the illusion created by the marketing teams to sell products beyond their value.

With this experience, the students had the opportunity to link the previous knowledge in geometry with algebra, and statistics. Besides, they have enhanced their inquirer and principled skills.

Such idea was nurtured by their desire of going out of the school and have some snacks, combined with curiosity about the reason why there are products that have some strange shapes.

The third activity was *"Maths flavoured popcorn"*. The students were tired; they had a long day of lessons, and when I arrived at the classroom they asked: "Miss Sousa can we watch a movie, please?". I thought why not, so we decided that we were going to watch *Step Up 5*. While the students were preparing the movie, there was a comment that made me structure this activity. I heard: "Do not worry Miss Sousa, I am sure there is Maths in the movie". The moment the student uttered that sentence, I asked them to stand out the moment where they found Maths as they were watching the movie, and where they could apply the previous concepts.

We had a fifty minutes period lesson, and we had watched nearly thirty minutes of the movie. So the question was what can we do with that movie and still keep up with our Mathematics lesson? After a quick thinking and conversation, we came to the idea that we could create a line graph to represent the increase of fondness for the dance moments that occurred during the time of the movie.

Relationships are the connections between quantities, properties or concepts that can be expressed as models, rules or statements. So, in the next lesson, the students restarted watching the movie. They had to select all the intervals of time where there were dancing beside their favorite Maths moments.

Until the end of the movie, the students had to identify and justify the variables and units and to achieve that they had to convert all the times into minutes and then plot on the axes. To conclude, they had to draw the graph, as you can see in Fig.3, while they were stating and explaining the aspect of the graph in the context of the movie.

With that project, the students were able to work with geometry, algebra, and numbers



while they were enjoying a movie and socializing.

The final and most pleasant project was "I bet on the Maths rider". This activity emphasised the idea of Mathematics as a result of the personal interests of the students and their abilities in embracing their uniqueness and profile.

One particular student in MYP 3 class, had been struggling to understand Maths concepts, however, due to all those different Mathematics experiences the student became more motivated and interested.



**Figure 3. Step Up 5 fondness line graph**

During a Mathematics lesson, while we were finishing the movie project, the student asked me if there was any connection between Maths and horses. She said that probably there was a connection, but if so, she was not able to identify it and that she was interested in exploring that relationship. Grabbing that idea, I asked her to prepare an activity for all the class.

Since that moment she became a teacher. To create an activity, she had to do research on the topic she would introduce her colleagues through horses. She had to set a statement of inquiry, questions that would give direction to teaching and learning, that would help her to organize and sequence the learning experiences.

Turning that activity into something useful to her own life, helped her come out with questions, such as: "How can I improve my horse paces? How can I measure the speed I go on the horse?". Looking at a topic as a logical process instead of a series of relationships or as a structure changes has enhanced her learning process.

The relationship between time and distance enables the students to graph data and model it with a linear function. In a real-life context, such relationship expresses the speed. Based on this concept, we have prepared and planned all the activity.

We went outside the school, to Palheiro Gardens - Horse field, where we had the first contact with the horses and we spent some time walking around the place.

During that time, the student wanted to make us understand her motivation to plan this activity. She taught us about horsemanship. We learned that horses are complex, sensitive animals, with an amazing ability to build relationships with people. Also, when trained, they willingly allow people to ride them, but they also need a lot of care.

After that moment, we started to perform the activity that we had divided into five main tasks.

In the first part of the activity, the students had to build a specific horse track for the experience. They had to consider the field, the size, and the stride of the horse and also, estimate the length of track needed for the experience. They used flowers to split the track in intervals of three meters long as you can see in Fig. 4.



**Figure 4. MYP3 Students building the horse track**

In the second part of the task, the students would be analyzing three of the four horse paces - walk, trot, and canter and fulfill a table

of values. Taking into account that the horse is not a machine, first they had to understand how the horse moves at each one of the horse paces.

They learned that walk was the slowest pace, and it has a four-time beat; the trot or jog was the rhythmic, swinging pace that has a two-time beat. Also, that the canter or lop was the lively, bounding pace that has a three-time beat, followed by a slight pause or "moment of suspension" when all four legs are in the air.

Afterward, they started stating the values of time and the distance while the most experienced horse rider, which was the driving student, was riding her horse.

In the third task, the students had to discuss, as a group, the results that they had observed. After that they used the cartesian plane to plot the relationship between the variables for each of the horse paces. The result was a linear graph that expressed the linear relationship between both variables. In the real-life context, the students interpreted as the rider was riding at all of the horses paces in a constant speed.

Succeeding a quick reflection the students thought about how they could calculate the speed and they came to the formula 1.

$$\text{Speed(m/s)} = \text{distance (m)} * \text{time (s)}^{-1} \quad (1)$$

They applied that formula, and they found the speed of each horse pace. Then they compared the results of the speed calculations with their plotting in the context of the experience. They observed what happens with graph when the horse goes faster or slower.

In the next assignment, the students had to repeat part of the second task, considering a few changes: they reanalyzed the horse pace - trot experience. The challenge was to observe what was going to happen to the graph and the speed if the horse started trotting after three seconds and also if it started three meters ahead.

At the end of that assignment, we discussed the results, and then we related it with the contents on the worksheet, Fig.5. The students were able to understand the concepts gradient and equation of a line easily.

As a final task, the students had to imagine and then prove what would be the expected

results if they increased or decreased the variables, but preserving the same speed of the horse pace.

They had to find, how far the horse would go if it were trotting for one minute, and also for how long it would take to ride for another one hundred metres.

As a group, the students were looking for a strategy to solve the problems in question. One of the possibilities was to repeat the experience with the horse and check the results again. However, they quickly understood that was going to take extra time to repeat over and over again the same procedure. Instead, to prove the predicted results, the students decided to describe the problem into an equation and substitute the data to reach the solution. They understood the benefits of applying mathematical strategies and the generalized forms.



Figure 5. MYP3 Students and teacher analysing the work sheet

By the end of the day, the driving student of this project was able to answer to the inquiry questions, and also to be able to understand how useful and exciting Mathematics can be. She said: "Now I know how to improve my horse riding. Maths is everywhere! Maths happens!"

If the conditions are right, Maths is inevitable, it happens all the time. Teachers are leaders, howbeit we should not just command and control. If we give our students a different sense of possibility, a different set of expectations, a broad range opportunities they will flourish.





**Figure 6. My teachers, MYP3 Students**

Instead of memorizing "tricks" as substitutes for conceptual understanding, they will develop the ability to analyse problems and engage strategies without the fear of failure.

Teachers face the dilemma of "getting children through the syllabus". However, I have been learning through my experiences, that if we do not treat our teaching like an unbreakable time schedule, our students will understand the concepts and generate the contents.

Furthermore, they have to feel that we are not rushing them through fulfilling the demands of a system. They have to feel that we will not let them apart if they do not reach the concepts, and that we will exhaust all possibilities to make them achieve the knowledge if they want to.

The relation that we create with our students must be real because they will understand if we are teaching or if we are performing. We cannot forget that we were students that have become the teachers, and we do not know if they will choose teaching as a profession. We do know they will be part of a globalized community, and they teach directly and indirectly with their voices and through their actions the next generation.

I believe that is why I am presenting this paper, because I had the opportunity to work with a class, Fig.6, that taught me not only Mathematics, but especially how to be their teacher. They made me believe even more that the students become the teachers of the present, and also of the future.

## 4. Acknowledgements

First, I wish to express my sincere thanks to Professora Doutora Elsa Fernandes for providing the opportunity to write this paper. Also, the support and knowledge throughout my learning to become a Mathematics teacher.

Secondly, I thank MADEIRA Multilingual School, for investing in professional development, and to my students, especially MYP3 for the shared learning.

Thirdly, I thank teacher Tânia Martins for reviewing my paper and to Escola da APEL for believing in my work since I was their student.

I also thank teacher Cátia Belim for the learning and the friendship. And, all my teachers, colleagues, and students for the teachings and for sharing their life experiences.

Finally, I also am grateful to my parents and goddaughter Andreia for the unceasing encouragement, support, and attention.

## 5. References

- [1] Breda A, Guimarães F, Guimarães H, Martins M, Oliveira P, Ponte J, Serrazina L, Sousa H. Programa de Matemática do Ensino Básico. Ministério da Educação: Direção-Geral de Inovação e de Desenvolvimento Curricular; 2007; p. 1-2.
- [2] Figueiredo O, Ferreira J, Pereira M. Guião: "Promoção do Empreendedorismo na escola". Ministério da Educação: Direção-Geral de Inovação e de Desenvolvimento Curricular; 2007; p.6.
- [3] Davis, Rinvolucri; 1991.
- [4] International Baccalaureate Organization; United Kingdom; 2014.
- [5] Liebeck P. How Children Learn Mathematics; Penguin Books; 1999; p. 237.

## Robots to Learn Statistics and Citizenship

PC Lopes<sup>1</sup>; E Fernandes<sup>2</sup>

<sup>1</sup>Middle and Secondary School Ângelo Augusto da Silva, Madeira, Portugal

<sup>2</sup>University of Madeira; Portugal

<sup>1</sup>crislopes@netmadeira.com; <sup>2</sup>elsa@uma.pt

**Abstract.** In this paper we report a small part of a broader study that is being carried out under the first author PhD, whose goal is to understand how the use of technologies, specially robots, helps students to develop statistical literacy, reasoning and thinking and their ability to problem-solving, producing meaning and enhancing learning. We assume as phenomenon under study - learning (of statistics and citizenship). In this paper we will analyse how learning of statistics and citizenship occurred throughout the search of the winner of a robot race.

**Keywords.** Educate for Citizenship, Learning Statistics, Robots, Statistical Literacy, Statistical Reasoning, Statistical Thinking.

### 1. Introduction

We are in the information age and the access by citizens, to social, political and economic issues is done increasingly early.

Daily we are faced with information and statistical analysis in magazines, newspapers and other media. Often this information is presented in a disguised form and the analysis of statistical data is not presented in a transparent and impartial manner.

It is important for all citizens to relate and critically analyse the statistical data they face every day. It is crucial that all citizens be able to react, in a critical, thoughtful and assertive way, to the information with which they have to deal. However, "(...) many research studies indicate that adults in mainstream society cannot think statistically about important issues that affect their lives" ([1], p.3). They are not able to understand and analyse the information in order to make decision in an informed thoughtful and argued manner.

Schools should provide tools that help citizens to react intelligently to information in the world around them.

In this paper we will discuss and analyse how learning occurred, in this mathematical practice, in which students search the winner of the robot race they made.

### 2. Learning Statistics

Statistic is envisaged, both in Portugal and internationally [2], as a tool for the organization, representation and processing of data relating to real situations, which empower students with the ability to appraise in an informed and critical way their uses in various fields, particularly in the media. Thus, its study should provide tools to cultivate informed citizens, able to analyse and react in a critical, thoughtful and assertive way to the quantitative information in the world around them.

Several researches in statistics education field, argue that when planning the teaching of this subject it is necessary to create situations that enable the development of statistical literacy, reasoning and thinking. However, it is apparent that when statistics educators or researchers talk about or assess statistical literacy, reasoning or thinking, they may all be using different definitions and understandings.

In this paper, we conceptualize statistical literacy, reasoning and thinking as the three components of statistics' competence and we discuss those components based in authors of reference such as Ben-Zvi and Garfield [1], Gal [3], Garfield [4], Mallows [5], Watson [6], Wodewotzki and Jacobini [7].

#### 2.1. Statistical Literacy

The expression 'statistical literacy' is usually used to describe the individual's ability to understand statistical data. Therefore, to have statistical literacy is central to a citizen to be able to understand the content published in a newspaper, on television and in the Internet, and to be active and critical in our society.

The term 'statistical literacy' is described by many researchers by different ways.

Garfield [4] describes statistical literacy as the ability to understand statistical information, this is, to correctly use statistical vocabulary, symbols and concepts, being able to interpret graphs and tables and to understand statistical information displayed by the social media.

Similarly, Gal [3] and Watson [6] define statistical literacy as the ability to discuss opinions, to interpret and critically evaluate statistical information and the arguments based on data that appears in multiple contexts, for example, in the social media, in professional or personal life, and to ability to communicate them and make informed decisions. This definition is broader than the one presented by Garfield [4], since that are considered various contexts where information can be displayed and includes, beyond the comprehension of information, its interpretation and critical evaluation, communication of results and decision-making.

To develop students' statistical literacy, we think that they need to learn how to use statistics to evidence, to argue and to justify situations that emerge in their everyday life, as students or as active and participatory citizens in society.

## **2.2. Statistical Thinking**

Such as in statistical literacy, there's not a consensus about the definition of statistical thinking.

Wodewotzki and Jacobini [7] state that statistical thinking may be assumed as a strategy to act. Accordingly, they consider statistical thinking as an analytic thinking.

With a broader definition, Mallows [5] presents statistical thinking as the ability to relate quantitative data with concrete situations and the ability to explain what the data express about the problem in focus.

Statistical thinking occurs when the individual is able to identify the problem under study and make an appropriate choice of statistical tools that are necessary for the description and interpretation of data. Thus, we can understand statistical thinking as the ability that an individual has to make decisions in each one of the stages of an investigative cycle. (Four-step cycle: (1.) Formulation of questions and design of the plan; (2.) Data collection; (3.) Representation and data analysis; (4.) Interpretation of data and formulation of conclusions [8], [9]).

Following these ideas, we consider that, to develop statistical thinking, students have to solve statistical problems that involve the

investigative cycle, instead of only solving statistical exercises. To do this, we must offer them situations that allow them to work their creativity and their critical sense and that promote reflection and debate.

## **2.3. Statistical Reasoning**

Statistical reasoning may be defined as the way people reason with statistical ideas or statistical concepts and give meaning to statistical information [1].

Statistical reasoning allows individuals to combine ideas about statistical data and to make inferences and interpretations about statistical results. Thus, the development of statistical reasoning enables a student to understand, interpret and explain a statistical process based on real data.

According to Silva [10], for a student to develop this kind of reasoning, he should live learning situations where he has to compare concepts and evaluate the most appropriate way to analyse a variable or a set of variables. The author argues that the central tendency and dispersion measures are sufficient to develop students' statistical reasoning.

Garfield [4] states that if students learn the concepts and procedures and if they have the opportunity to work with real data, using statistical software, they will be developing their statistical reasoning.

Surely it will be possible to help students to develop their statistical reasoning if, in their daily school practice, the teacher proposes statistical investigations and encourage students to verbally describe the statistical process that they are examining.

## **3. Learning Citizenship**

Celi Lopes [11] defines citizenship as the ability of an individual, in his social group, to act in a reflective, thoughtful and critical way.

Juliana Schneider and Rosemari Andreis [12] report that to exercise citizenship, especially in a society geared to knowledge and communication it is essential that students know how to communicate ideas, perform procedures, construct and interpret tables and graphs, estimate and make logical inferences and analyse data and information.

D'Ambrósio [13] refers that Education for citizenship, which is one of today's education goals, requires a "consideration" of modern knowledge, steeped in science and technology.

According to the way we conceptualize statistics learning in this paper (based on the development of statistical competence) to talk about statistics learning it is synonymous of talking about learning citizenship. So, the study of statistics will provide tools for the exercise of citizenship.

Environments that allow students the construction of concepts and the development of skills will help them in the exercise of their citizenship and thus broaden their chances of success in professional and personal life.

Teachers and students should be involved in the design and implementation of learning scenarios [14] in which students participate actively in their learning process. In this sense we created and implemented the learning scenario: Robot Race [15].

#### 4. Research Methodology

The nature of this research is qualitative with an interpretative character due the nature of research problem [16].

The participant observation was a central strategy in data collection, enabling a close and personal contact with students.

The learning scenario - Robot Race - was implemented in a 8<sup>th</sup> grade class of a Middle school in Madeira Island, where 14 students (ages between 12 and 15 years old) worked together with robots, following a project methodology [17].

During nine sessions, 90 minutes each, math teacher and the researcher participant in data collection, worked together implementing the learning scenario. It was the researcher that guided the discussions.

We recorded all sessions with two video cameras and the emphasis was in students' interactions.

#### 5. The Learning Scenario: Robot Race

With this learning scenario students had their first experience with LEGO MINDSTORMS NXT's robots and with its

programming environment.

To work with NXT robots, students received assembling kits and had the opportunity to build in group, a car out of Lego bricks, following instructions. The place for the light sensor was specifically indicated but all remaining robot design was done according with students' options.

Students programmed and carried out between robots in three different moments: i) they programmed the robot to run around four tables arranged in pairs (forming a rectangle); ii) they held races in a straight line from side to side of the classroom. Robot should stop when it detect a wall (*ultrasonic sensor*); iii) they had programmed, taking into account that, the robot would have to: start the race upon the starting signal (*sound sensor*), to follow a black line (*light sensor*) and to stop 15cm before the end of the line (*ultrasonic sensor*).

Each working group has created a prototype of a race route, with provided parts, so that two robots can race simultaneously. Each two robots need to have the same chance to win.

In the large group, students chose the race route to be used and then they have built it with real dimensions. They decided that, for all robots run under the same conditions, each one would have to run twice, against each opponent, once in each line of the race route.

The races were held, and from this moment onwards students could improve their programming to have a better chance to win.

Each working group collected data and worked it in order to choose the winner robot.

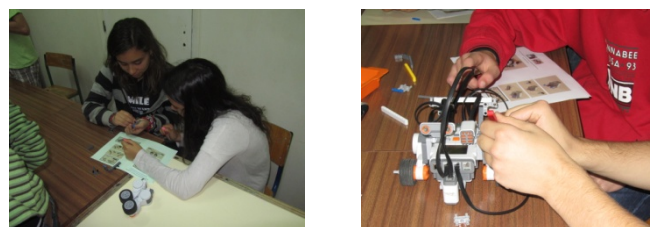

Figure 1. Robots' construction using Lego bricks

With the collected data from the races, each group made a statistical study where conclusions were provided and generalizations were established. Statistical contents emerged from the participation of students in that practice.



## 6. Learning with the Robot Race

### 6.1. Robots Construction and Programming

Students built their own robots and they were free to put on them all the accessories they wanted. This was very important because has contributed for students to learn the parts that make up LEGO kits and the morphology of the robot. Moreover, it allowed students to work independently, to discuss among themselves what they were doing and help each other.

Considering that each robot had a specific morphology, the programming was not the same for all working groups. It was necessary to adjust the programming to the morphological characteristics of each robot.

Students felt the need to make measurements when it was suggested them to "program the robot to stop when the robot is about a 15cm distance from the wall".

The place where students put the ultrasonic sensor on the robot, affected its programming. In order to achieve an effective programming to the requested task, the students measured the distance between the end of the ultrasonic sensor and the front of their robot.

The programming and its testing was a dynamic process and it was part of students' practice. In this process of modifying their programming, students developed the communication and the ability to build strategies, since they had to justify and negotiate with the peers in the group, the programming they were doing.



Figure 2. The built robots (cars)

When students created, negotiated and justified their procedures, they developed their ability to argue and to reason. By programming, and trying to explain their own program, students have established and justified logical connections between the programming they have done and the robot performance. This process was important and fundamental for the

development of an increasingly efficient and effective programming.



Figure 3. Two robots with the ultrasonic sensor on different locations

The challenges posed to the students awakened competition (students from each group competed to program their robots more quickly and effectively than others) and interest on programming. Besides, it was important to the process of involving students in the practice.

The different working groups defined their goals and negotiated meanings in order to successfully address the posed challenges. In the process, they discussed, experimented, negotiated and changed their programming.

In each formulated and negotiated attempt to solve a problem, students have become agents of their own knowledge and built their own learning process.

### 6.2. Construction, Presentation and Choice of a Race Route

To the construction of the prototype of a race route it was provided to each working group 24 small parts: 12 straight parts and 12 curved parts. Students were informed that they had to construct a race route that it was fair for two robots race simultaneously. The following conditions were placed: (i) the race route had to fit in the classroom; (ii) each part of the prototype was 15 times smaller than the real one; and (iii) it was not necessary to use all the small parts given in the prototype's construction.

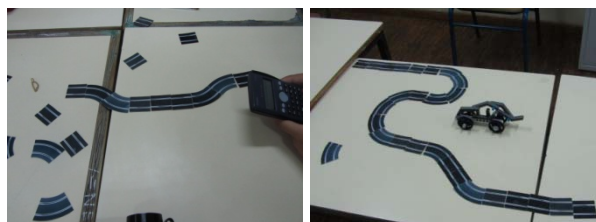
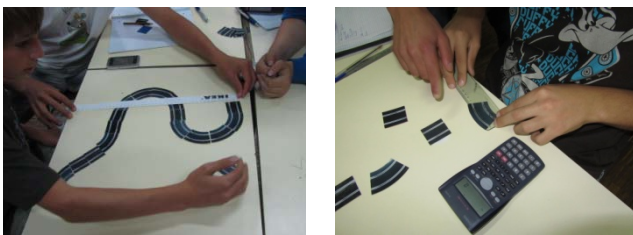

Figure 4. Prototype's construction of a race route

It was clear to us that it was part of the shared knowledge of this class that "to be a fair race route the length of the two lanes had to be equal", but not all students knew the conditions for that happen. Together students built the concept of 'fair race route' and also the prototypes in the established conditions. To do that, students appealed, such as in other moments, to examples of non-school practices.

The fact that students shared their individual perspectives on the issue, contributed to the knowledge of all students about what is a 'fair race route'. This aspect has become part of a shared knowledge of these students and enabled the creation of a race route with the established conditions.

All working groups explained why their prototype was a fair race route, but none has mentioned if the constructed race route fit in the classroom. Only when students were asked if the race route fit in the classroom, they felt the need to make measurements.



**Figure 5. Changing the prototypes of a race route to "fit" in the classroom**

After a few advances and retreats, all working groups created a fair prototype, possible to be built in the classroom. To do that, they had to be able to look critically at their objects (prototype and classroom) and interpret them appropriately.

Each working group presented its prototype to the class. The class decided voting as a way to choose the race route to be used - here students made their first statistical study and explored some statistical concepts.

When it was over the counting vote (5 votes to prototype 1, 8 votes to prototype 2 and 1 vote to prototype 3) a student said "We already have our problem solved. The mode is the prototype 2, because of that, this prototype won".

After that another student added: "Yes, the prototype 2 is the one that has more votes, we

say that it is the mode. There are no draws. It has mode, that it is the prototype 2".

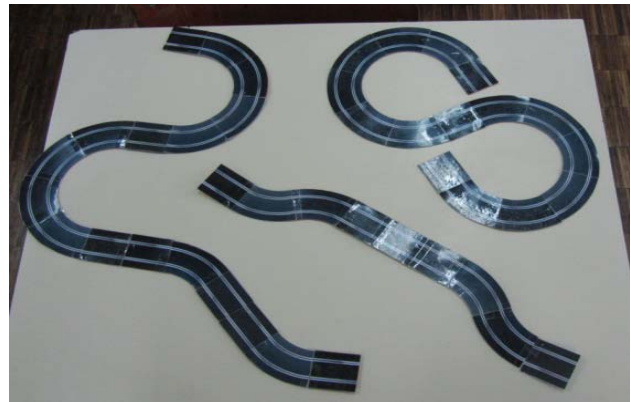

**Figure 6. The prototypes of a race route built by students**

The teacher asked what was the variable under study. The students answered that were the prototypes and added that the variable was qualitative.

These statements showed that students had statistical literacy, once they were able to interpret and critically evaluate the situation and make a decision about the information gathered in the voting process. Besides, they were capable of reason about data [18] because they recognized the statistic variable, its nature and categories, and used a suitable measure, in this case the mode.

The dialogue between teacher, researcher and students followed in order to discuss and differentiate concepts such as: population and sample, census and survey and to clarify that, in that study, data collection was done by vote. This dialogue has emerged because both teacher and researcher had the intention on address those concepts, in order to expand students' statistical literacy. It was also discussed the importance of choosing a representative sample of the population and about necessary cautions to have on sampling.

### 6.3. The Races

After some attempts, students programmed their robots in order to correctly make the races. Students followed the proposed conditions, namely, the robot would have to: start the race upon the starting signal (*sound sensor*), follow a black line (*light sensor*) and to stop 15cm before the end of the line (*ultrasonic sensor*).

The assembly of the racing route and the time that students made the races, can be characterized as moments of mutual help among students from different working groups. Those moments also provided the union of all class. Students shared tasks and each group collected the data that they considered important to define the winner robot and to robots' classification. The work was distributed among students on a very natural, orderly and effectively manner.



**Figure 7. Programming for the races**

In the course of learning scenario's implementation there was a greater autonomy and better management on task sharing by students. They started, progressively and naturally, making decisions without first questioning teacher or researcher.

The realization of racings with robots gave students the opportunity to produce their own data and find the desired results and helped them to take charge of their own learning.

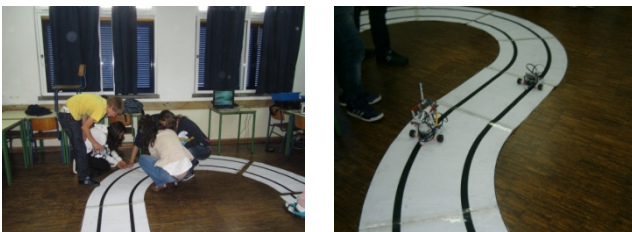

**Figure 8. The assembly of the racing route and the robot races**

After twelve racings, the data collection phase was terminated.

#### **6.4. The Winner Definition**

In this phase, students had to analyse the data collected during races and convert them into relevant information to answer the questions asked. Students had to establish criteria to select a winner robot for the races.

Each working group chose a representation and (or) a statistical measure that they

considered suitable to analyse data. In this process they took into account the nature of the variable under study and the previously purposed.

Students used the Excel spreadsheet to organize the collected data. They analysed those data and found arguments to choose a winner robot for the races. In addition, students have set criteria for the classification for all robots.

Most of the students had never used the Excel spreadsheet and did not know its potential. By experimenting and sharing information, students were able to use Excel formulas to perform calculations (sums, means). They also built graphs to organize information. This tool proved to be important both to analyse the data and for the data representation through graphs and tables.

By establishing the criteria for a robot to be a winner, students presented and discussed their perspectives on the situation. This led the emergence of varied and original strategies. They were able to interpret and critically evaluate the collected information during the races, use and establish statistical relationships in order to define the winner, using analytical methods, exploring the data in order to extrapolate issues beyond teacher and researcher's expectations.

The arguments and strategies explained by students were based on mean, minimum and maximum of data set. In all cases, students had to explain the meaning of the statistical contents they were using on this situation.

Students showed evidence that they developed their statistical thinking [19], because they were able to identify the statistical concepts and they proved to have ability in dealing with them in the context of the situation under analysis.

Some concepts used by the students were availed by the teacher and the researcher to bring out other statistical concepts (such as extremes and amplitude of the sample) and, therefore, continue to promote the development of statistical literacy.

All students were capable of interpret and critically evaluate the collected information, to use and establish statistical relations to define

the winner robot, using methods of analysis, exploring the data in order to formulate conclusions. They were also able to explain the process created by their group to set the winner robot, showing that they have extended their reasoning and statistical literacy.

Students developed their statistical reasoning [20], because they were capable of understand, interpret and explain the statistical methods based on data collected during the races.

Despite the apparent justice of all criteria established by the working groups, we cannot overlook the fact that, in most cases, students defined a valid argument to make their robot be the winner. This reveals that students reflected about the data and they were capable of choose which was the best central measure, to define the winner robot. Thus, we consider that students developed their reasoning about statistical measures [18].

During the discussion about the criteria to establish the winner robot, students presented and argued their perspective on the situation and defended their opinions, revealing that they have acquired and developed statistical literacy [3], [6].

In all class, students had to relate the data with the situation under study and explain what those data expressed about the problem in focus. Therefore, they used and developed their statistical thinking [5].

## **7. Conclusions**

Paulo Freire [21] argues that “ (...) when a men understand its reality, can arise hypotheses about the challenge of this reality and find solutions” (p. 30).

To provide a relevant context – Robot Race – combined with the sense of challenge and competition that emerged, has contributed to develop a seeking of solutions by the students.

Robots assembling, their programming and making the robot races, were important moments in this classroom practice, in which students worked cooperatively. In those moments, students proved to be motivated to learn and happy with the work they were carrying out. They never gave up.

To work with robots allowed the emergence

of students' statistical literacy [3], [4], [6] once they had opportunity to: i) organize data that were part of their reality; ii) interpret and critically evaluate statistical information; iii) argue relatively to data collected; iv) elaborate strategies and justify procedures; v) discuss or communicate their conclusions; vi) take informed decisions. By doing this, students developed their ability to act in a more responsible, reflective, thoughtful and critical manner, that is, to learn citizenship [11], [12].

Statistical thinking is related to the ability to identify the statistical concepts involved in the investigations and problems and the ability to deal with them, considering the nature of data variability. A way that we found to encourage students' statistical thinking, was not accepting any numerical result without being explained and related to the context, that is, with the situation being studied. Students have collected the data and, thus, they have recognized the context in which they were collected and the purpose of its use. They were able to reason with ideas and statistical concepts, giving meaning to statistical information.

The students were able to relate the data and explain what they expressed, using statistical tools. They used methods of analysis and assessment, exploring the data, thereby demonstrating they have developed statistical thinking [5].

With the data collected, in the races, students used statistical relationships to define the winner robot, using methods of analysis and estimation, exploring the data in order to extrapolate questions beyond teacher expectations. By doing this students have developed statistical reasoning [1] because they were able to understand, interpret, and explain statistical methods based on real data (races data).

We believe that, with this work with robots, students have become more able to solve problems, to understand, to interpret, to analyse, to relate, to compare and synthesize data, therefore, they developed statistical competence and citizenship.

## **8. References**

- [1] Ben-Zvi D, Garfield J. Statistical literacy, reasoning, and thinking: goals, definitions, and challenges. In: Ben-Zvi D, Garfield J



- editors. *The Challenge of Developing Statistical Literacy, Reasoning and Thinking* (p. 3-15). Dordrecht, The Netherlands: Kluwer Academic Publishers; 2004.
- [2] NCTM. *Principles and Standards for School Mathematics*. 2000.
- [3] Gal I. editor. *Adult Numeracy Development: Theory, Research, Practice*. Cresskill, NJ: Hampton Press; 2000.
- [4] Garfield J. The statistical reasoning assessment: Development and validation of a research tool. In: Pereira-Mendoza L, Seu Kea L, Wee Kee T, Wong W, editors. *Proceedings of the Fifth International Conference on Teaching Statistics*; 1998 Jun 21 – 26; Voorburg, The Netherlands: International Statistical Institute; 1998, vol. 2, p. 781-786.
- [5] Mallows C. The Zeroth Problem. *The American Statistician*. 1993; 52: 1-9.
- [6] Watson J. Assessing statistical thinking using the media. In: Gal I, Garfield J editors. *The Assessment Challenge in Statistics Education*. (p. 107-121). Amsterdam: IOS Press and International Statistical Institute; 1997.
- [7] Wodewotzki MLL, Jacobini ORJ. O Ensino de Estatística no contexto da Educação Matemática. In: Bicudo MAV, Borba MC, editors. *Educação Matemática: pesquisa em movimento*. (p. 232-249). São Paulo: Cortez; 2004.
- [8] Martins ME, Ponte JP. *Organização e tratamento de dados*. Lisboa: ME-DGIDC; 2010.
- [9] Selmer S, Bolyard J, Rye J. Statistical reasoning over lunch. *Mathematics Teaching in the Middle School*; 2011; 17(5): 274–281.
- [10] Silva CB. *Pensamento estatístico e raciocínio sobre variações: um estudo com professores de matemática*. Tese de doutoramento em Educação Matemática. Pontifícia Universidade de São Paulo. São Paulo. 2007. <http://iase-web.org/documents/dissertations/07.Silva.Dissertation.pdf> [visited 1-jun-2015]
- [11] Lopes C. O Ensino da Estatística e da Probabilidade na Educação Básica e a Formação dos Professores. *Caderno Cedes*. Campinas 2008; 28(74): 57-73. <http://www.cedes.unicamp.br> [visited 2-Jun-2015]
- [12] Schneider J, Andreis R. Contribuições do Ensino de Estatística na Formação Cidadã do Aluno da Educação Básica. [http://www.uniedu.sed.sc.gov.br/wp-content/uploads/2014/04/juliana\\_schneider.pdf](http://www.uniedu.sed.sc.gov.br/wp-content/uploads/2014/04/juliana_schneider.pdf) [visited 1-Jun-2015]
- [13] D’Ambrósio U. *Educação Matemática: da teoria à prática*. 4. Campinas, SP: Papyrus; 1996.
- [14] Wollenberg E, Edmunds D, Buck L. *Anticipating Change: Scenarios as a Tool For Adaptive Forestmanagement. A Guide*. Indonesia: SMT Grafika Desa Putera; 2000.
- [15] Lopes C. In: Fernandes E, editor. *Aprender Matemática e Informática com Robots*. (p. 86-95). Funchal: Universidade da Madeira; 2013. [www.cee.uma.pt/droide2/ebook/index.html](http://www.cee.uma.pt/droide2/ebook/index.html) [visited 11-Jun-2015].
- [16] Bogdan R, Biklen S. *Investigação Qualitativa em Educação: Uma Introdução à Teoria e aos Métodos*. Porto: Porto Editora; 1994.
- [17] Greeno JG, MMAP. The situativity of knowing, learning and research. *American Psychologist* 1998; 53(1): 5-26.
- [18] Garfield J, Gal I. Teaching and Assessing Statistical Reasoning. In: Stiff L editor. *Developing Mathematical Reasoning in Grades K-12: National Council Teachers of Mathematics* (p. 207-219). Yearbook, Reston, VA: Ed. L. Staff; 1999.
- [19] Chance BL. Components of Statistical Thinking and Implications for Instruction and Assessment. In *Journal of Statistics Education* [Online], 2000; 10(3). [www.amstat.org/publications/jse/v10n3/chance.html](http://www.amstat.org/publications/jse/v10n3/chance.html) [visited 21-Jun-2015]
- [20] Garfield J. The Challenge of Developing Statistical Reasoning. In *Journal of Statistics Education* [Online], 10(3). [www.amstat.org/publications/jse/v10n3/garf](http://www.amstat.org/publications/jse/v10n3/garf)

ield.html [visited 10-Jun-2015]

[21] Freire P. Educação e mudança. 27. ed. Rio de Janeiro: Paz e Terra; 2003.

---

---

## Recreational Angler Management in Marine Protect Area: a Case Study of Top-bottom Management

F Encarnação<sup>1</sup>, S Seixas<sup>1,2</sup>

<sup>1</sup>Universidade Aberta, Lisboa, Portugal

<sup>2</sup>Universidade de Coimbra, Portugal

fencarnacao@gmail.com,

sonia.seixas@uab.pt

**Abstract.** This study is done in a natural park (Southwest Alentejo and Vicentina Coast Natural Park - PNSACV) a marine area with an extension of two km offshore all along its coastline (Marine Protected Area - MPA).

The “recreational fishing” it is part of the tradition of the people living in these near municipalities, having inherited a taste for rock fishing and shell fishing of their ancestors.

They are deprived of a moment's notice based on a law without being heard, without anyone to defend the tradition inculcated in each. In this park, since 2006, with the first law (868/2006) several fishing management measures have been implemented like, limitations and prohibitions without studies and licenses based on dissuasive law.

In practice, the process was reversed. What should be awareness and public participation became a force against the will of the people.

The another law (Portaria 143/2009) for de PNSACV area it's even more restrictive, separating the principle of equality between nationals and resident people in PNSACV, compared to the law (Portaria 144/2009) for the entire national territory.

These restrictions were not accepted by the population who express their discontent in Sagres, Odemira, Vila Nova de Milfontes and the Assembly of the Republic in Lisbon. A working group was created and a law was changed revoked.

Currently, the most relevant restrictive measures are the “false” temporal limitation to catch white seabream, because it's only effective for rock angler; established minimum sizes and weight maximums for marine organisms like, crustaceans, bivalves, gastropods, mollusks and fish; angler fishing licenses are required.

Populations and commissions were heard and the scientific community begin working with the anglers in some studies. All should have been started here.

**Keywords.** Marine protect area, recreational fishing, angler, marine organisms, restrictive measures, rock fishing, Southwest Alentejo and Vicentina Coast Natural Park, top-bottom approach.

### 1. Introduction

#### 1.1. Approaches to MPAs

Marine protected area – “any area of land between tides (tidal) or subtidal, in conjunction with the water it overlying and the fauna, the flora, and the characteristics and historical cultural associated with it, which has been reserved by law to protect all or part of the environment included” in IUCN, 17th General Assembly (1988) [1]. Marine Protect Areas (MPAs) are tools for ecosystem based fisheries management [2].

The ways to implement and govern MPAs have different approaches [3]:

- Top-bottom
- Bottom-up
- Marked-based

Top-bottom approach consist in states taken decisions and implement it through laws and regulations. The decisions are taken by expert advice and politics.

Bottom-up approach involve all the different players of community. The decisions are incorporate several opinions and points of views. There were examples of this approach, with success, in Portugal [4] and in Chile [5].

Marked-based approach is though markets using economic and properties rights.

As statement Gaymer *et al.* (2014) between bottom-up and top-down approaches, diverse variations or combinations of participation and governance exist [6].

#### 1.2. Study area

This study is done in a natural park - Southwest Alentejo and Vicentina

Coast Natural Park (PNSACV) located in Southwest of Portugal (Fig. 1). It covers a land area of 60 567 ha and a maritime zone with 28 858 ha.

The PNSACV has a marine area with an extension of two km offshore all along its coastline (Marine Protected Area - MPA).

The coast is composed of oceanic sandy beaches, extensive rocky shores, small estuaries and coastal bays. The PNSACV has an extension of 130 km including in the municipalities of Sines, Odemira, Aljezur and Vila do Bispo.



Figure 1. Southwest Alentejo and Vicentina Coast Natural Park – PNSACV (green area), in Portugal

There are two types of protection schemes: the total protection (areas of total protection Article 63. ° RCM no. ° 11-B/ 2011) and the partial protection I (areas of partial protection I Article 65. ° RCM no. ° 11-B/ 2011).

The areas of total protection correspond to spaces where predominate systems and natural values of recognized value and interest, with a high degree of naturalness, which are, on the whole, a unique and exceptional

character, as well as high ecological sensitivity, corresponding to important areas of marine production, besides being places of refuge and motherhood for many species.

These areas comprise the reefs and rocky outcrops and a surrounding marine area with a width of 100 m, counted from the minimum level of the low tide of equinoctial waters.

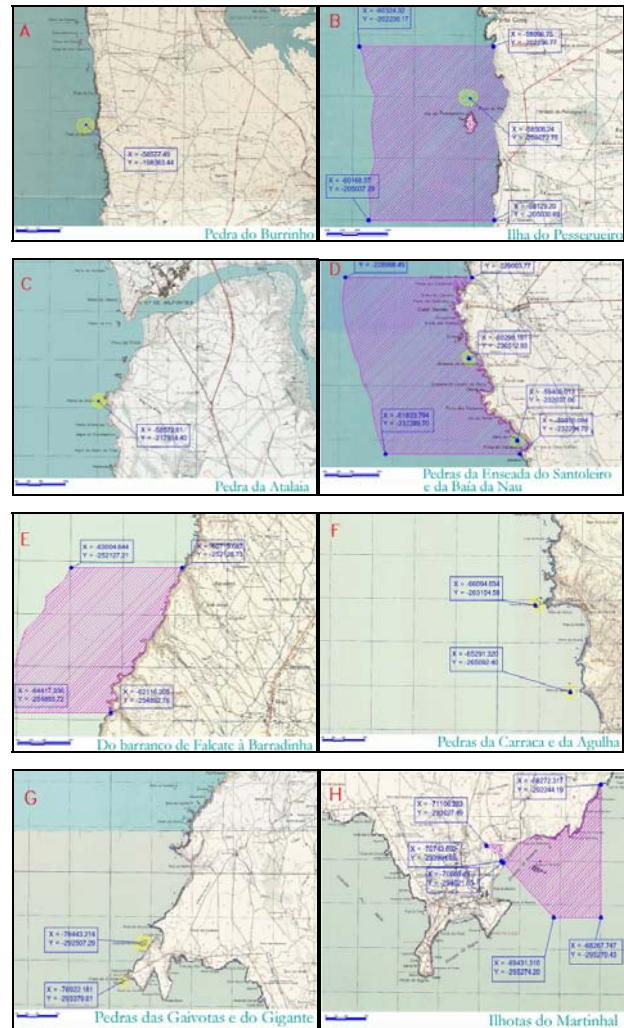

Figure 2. Arrangements for Marine protection (POPMSACV/ICNB). In yellow areas of total protection and in purple areas of partial protection. From:

<http://www.icnf.pt/portal/ap/resource/ap/pnsacv/pnsacv-maritim-interdit-pesca>

The reefs and rocky outcrops are Pedra do Burrinho, Pedra da Atalaia, the adjacent rocks to the Ilha do Pessegueiro, Pedra da Enseada do Santoleiro, Pedra da Baía da Nau, Pedra da Carraca, Pedra da Agulha, Pedra das Gaivotas and Pedra do Gigante (Fig. 2).

The priority goals of these areas is create a reserve of marine biodiversity and refuge for



some species; ensure the maintenance of values and natural processes tend undisturbed state; preserve ecologically representative examples in a dynamic and evolutionary form.



Figure 3. 22 February 2009 manifestation was organized in Sagres

### 1.3. Recreational Angler

The populations of sea areas always had as a tradition the following activities: fishing, sea food picking and bivalve molluscs harvesting. These activities are mainly practiced for subsistence or socialization. In the regions of Alentejo and Vicentina Coast, where the population is older and has a lower salary, the fishing ends up being an indispensable supplement to the family income.

Harvest by recreational fisheries has been estimated at about 12% of take worldwide for all fish (Cooke & Cowx 2004 in [7])

Veiga et al. (2010) in a study done between August 2006 and July 2007 estimated value of 147 t of fishes were harvested with an overall catch per unit effort (CPUE) of 0.21 kg.h<sup>-1</sup> per angler in PNSACV [8].

## 2. Legislation

In *Portaria* 868/2006, of 29 August, was implemented the follow measures:

- It was only allowed capture with hands, feet and with helped of an animal, so is not permitted to collect seafood with any instruments;
- It is not allowed to use bait;
- Maximum weight of 10 kg of fish/day;
- Maximum weight of 0,5 kg of barnacles;
- Night fishing was not allowed.

This also establish the closed period of barnacles (*Pollicipes pollicipes*), in winter which is strange because the barnacle reproduces during spring. Another thing that is amazing is the permission of captures barnacles with the help of an animal, something never done and completely senseless.

In *Portaria* 143/2009 law, is even more restrict in some points:

- The days for recreational fishing were reduced (Thursday - Sunday and Holidays);
- New interdiction zones were created;
- The maximum total weight of fish/day was reduce;
- It was created a closed period for *Diplodus sargus* (white seabream) and *Diplodus vulgaris* (commom two-banded seabream) from 1st January to 31st March and *Labrus bergyllta* (ballan wrasse), 1st March to 31st May;
- The collect of barnacles until 1 kg, was allowed only to recreational angler license holders who are natural or residents of the municipalities PNSACV;
- Night fishing was allowed only with life jacket use in PNSACV.

## 3. Public contestation

With the release of *Portaria* 143/2009 from the 5th of February, that defines the specific constraints in the recreational fishing activity at the SW Alentejo Natural Park and Vicentina

coast (PNSACV), the public contestation started. This discontent was widespread, and in the area of the Algarve emerged a movement of fishermen who joined in the protest and their spokesman Antonio Neves has organised the 1st demonstration of the history of leisure fishing 22 February 2009, in Sagres (Fig. 3).

At that time the new restriction measures for leisure fishing were already in force at the Natural Park from Sudoeste Alentejano and Costa Vicentina (PNSACV).

This event was attended by around 3,000 fishermen, coming from all the points of the Algarve and Alentejo, next to the Sagres Fortress. They demonstrated against the decline in the number of fishing days, new zones of inhibition, reduction of the maximum weight of fish and the creation of a closed season for white seabream, common two-banded seabream and Ballan wrasse.

After an idle car, between Lagos and Sagres, organised by a civic movement that "sea of people" met in the village, to protest against the Portaria 143/2009, published in the daily of the republic on the 5th February.

"I am against all restrictions", stated Joseph Gregory, one of the fishermen that goes up to the Vicentina coast to "entertain a little".

The opinion was general, because nobody understood the reason why they banned "fishing, between Monday and Wednesday, and during the night, and have created many zones of inhibition", added the practitioner, pointing to the various posters that showed the indignation of the demonstrators.

*Private Sea? No, thanks!* This was the slogan created by David Rosa another spokesman of the Commissions of Fishermen and Population of the Alentejo and Vicentina Coast that fought until the date for which the changes were made, in the fight of the fishermen and seafood catchers against Government guidelines which put into question the leisure fishing law. The symbol of this campaign can be seen in Fig. 4.

Another movement was created in the Alentejo coast, consisting of three dozens of committees of leisure fishermen from Sudoeste Alentejano and Vicentina coast to represent the interests of the fishermen of coastal strip from

Sines to Sagres.



Figure 4. Symbol of the campaign *Private Sea? No, thanks!*

Were it not for the social consequences, one could laugh, according to Carlos Carvalho, spokesman of the Commissions of Fishermen and Population of the Alentejo and Vicentina Coast, "nobody moves toward the coast to catch half a kilo of dished, still on top, without tools manufactured for this purpose, but only with the hands or the feet". "The fines imposed on seafood catchers, since almost two years ago, by nabbing seafood with utensils already amounted to 25 thousand euros." In addition, "the areas of harvesting are difficult to access," he stresses.

But the contestation also arrives to shellfish picking, which is an old fight. With the new measures, the people that live outside of the Natural Park cannot catch any kind of specie. It is argued that this restriction violates the principle of equality of the Portuguese Constitution.

What is certain is that the measures would damage the economy of the three municipalities integrated in the Natural Park (Aljezur, Vila do Bispo and Odemira), because it is the leisure fishing that maintains the small trade in months of low season tourism.

On the 27th February 2009, it took place the public deed of the National Association of Recreational and Sport Anglers (ANPLED), which was founded to defend the recreational angler's legitimate rights (Fig. 5).

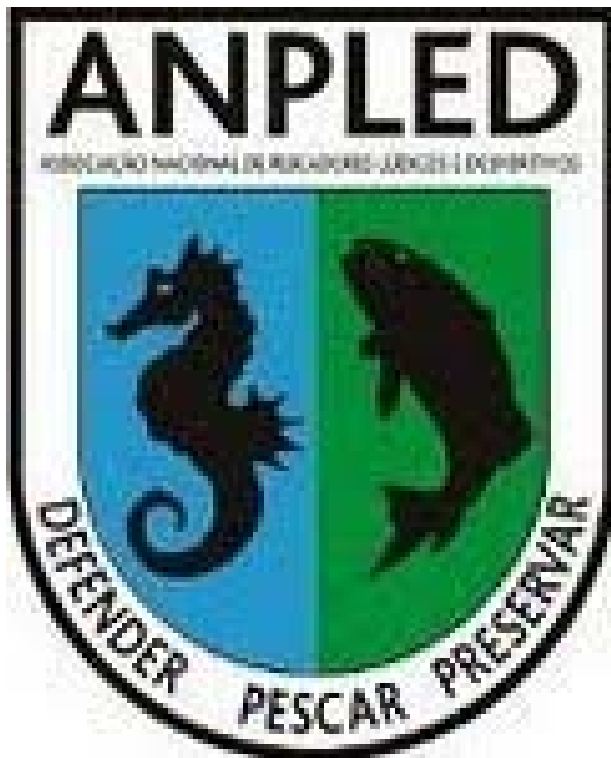

Figure 5. National Association of Recreational and Sport Anglers logo- ANPLED

Contacts and meetings with the Secretary of the Environment Ministry were made, with the objective to review the recreational fishing regulation in the PNSACV area. In its follow-up, ANPLED, wrote and sent a modification proposal of the Portaria 143/2009 from the 5th of February, to the mentioned entity.

On the 16 March 2009 a new manifestation was organized in Odemira to challenge the law, having counted with about three thousand people (Fig. 6).

Posteriorly the Portaria 143/2009 from the 5th of February, was modified by the Portaria 458-A/2009 from the 4th of May, the major changes are:

- In shore/boat fishing, live baits and chumming is allowed;
- Recreational fishing is allowed during all days except on Wednesday and on holidays;
- Between the 15th January and the 15th March fishing for *Diplodus sargus* and *Diplodus vulgaris*, is forbidden.

Were also organized protest actions, with meetings in various locations, which have culminated in a meeting in Vila Nova de Milfontes, on the 30th May 2009.

After these events, the fishermen were received by the secretary of State for the Environment, "there are indications that the law is in a process of change," adding, however, that "the fishermen are not satisfied with some of the proposals for change", in particular the desire to open up an exception for the residents of the Natural Park from Sudoeste Alentejano and Vicentina coast- those who have mobilised -, leaving out large populations of counties outside of PNSACV.



Figure 6. 16 March 2009 manifestation was organized in Odemira

Afterwards in the second modification to the Portaria 143/2009, the Portaria 115-A/2011 from the 24th of March, the major changes are:

- Recreational fishing (all modalities) is totally forbidden, in the total protection areas and in the partial protection areas – type I, (defined in the development plan of PNSACV);
- At PNSACV, Recreational fishing is totally forbidden on Wednesdays, except on national holidays;
- Recreational fishing during the sunset and sunrise only can be practiced if a life and reflective jacket is used, regardless where



- the fishing activity takes place;
- Between the 1st February and the 15th of March, fishing for *Diplodus sargus* and *Diplodus vulgaris* is forbidden
  - Authorization to use traditional adapted tools, namely 'arrilhada', 'puxeiro' ou 'bicheiro'.

#### 4. Actual legislation

The government creates a working group with entities, associations, committees of fishermen, log several working meetings and together draw up a new law.

Government capitulates in leisure fishing by extending the quantity of fish and seafood and authorizes the use of traditional tools, changing the regulation of the sector.

In the new legislation, two stand out: the changes introduced in the Natural Park of Sudoeste Alentejano and Vicentina coast (PNSACV).

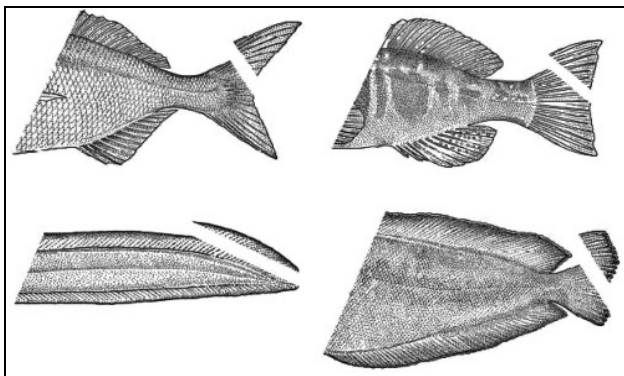

Figure 7. Mandatory marking all the specimens.  
From *Portaria* 14/2014, of 23 January

Currently there is a legislation fairer and less restrictive (*Portaria* 14/2014, of 23 January), with a national character, thus there is no longer the constraint of a proper law for the PNSACV. However there may be some constraints, in particular areas of partial and total protection, imposed by POPNSACV - Development Plan of the Natural Park of Sudoeste Alentejano and Vicentina coast.

- Fishing from shore/boat, the limit goes from 7.5 kg to 10 kg, plus the largest specimen;
- In spearfishing, limit changes from 7.5 kg to 15 kg, plus the largest specimen;

- For marine organisms, excluding fish and cephalopods, limit is 2 kg;
- It is authorized to capture 3 kg of mussels (*Mytilus spp*), 5 kg of oysters (*Crassostrea spp.*) and 5 kg of Japanese clams (*Ruditapes philippinarum*);
- The capture limit per day for annelids is 0.5 liters per person;
- In boat fishing with more than three 3 practitioners, the total limit of the catches cannot exceed 25 kg, plus the largest specimen;
- Every time that these limits are reached it is prohibited continue fishing;
- The fish can only be transported by the leisure fishing practicing who has made the captures;
- Between the 1st February and the 15th of March, fishing for *Diplodus sargus* and *Diplodus vulgaris* is forbidden;
- It is mandatory marking all the specimens, before leaving the fishing spot (cross-sectional cut in the fish's tail) (Fig. 7).

#### 5. Discussion

The *Portaria* 143/2009 intended to regulate the leisure fishing in Natural Park from Sudoeste Alentejano and Vicentina coast, alleging excessive practicing and danger in depletion of marine resources.

The measures outlined, particularly a closed season of 3 months for sea bream fishing and the prohibition of fishing from Monday to Wednesday, are absurd and unfair, because they don't apply to the rest of the national territory, nor the commercial fishing, placing the conservation responsibility of white seabream only in leisure fishing, in the area of PNSACV.

Against all the principles of fairness, these measures that come in the wake of other, worsen the conditions of life of those who live in PNSACV, and harm all the most disadvantaged, who have in the leisure fishing a traditional food supplement of first importance.

The law came thus deepen further the social and economic crisis in PNSACV, and acerbate

the just uprising of its population against the autistic and arrogant tutelage from the ICNF (Institute for Nature Conservation and Forests, the old name was *Nature and Biodiversity Conservation Institute*). Transforming ancestral life styles in illegal practices and turning increasingly unsustainable the existence of people who lives in the Natural Park it isn't an effective method for the natural resources conservation actions.

This approach of bot-down unleashed a serial of public manifestations done by recreational fishers.

This also occur in Florida with fishers felt highly alienated from the process of what they considered to be an attempt to exclude their group from the harvest [9].

The human dimension and socio-economic and sociocultural aspects is very important when is stablishing MPAs (e.g. [9], [10], [11], [12]) and in this case was not considered in the beginning.

Only after several actions showed the discounted the official services start to work with recreational fishers to design new legislation.

Recreational Fishers is an interested part in the process. A study in Cap de Creus (MPA) also statement that recreational fishing has a large economic effect on the local economy [13].

In different parts of world, of engaging recreational fishers in management and conservation concluded that recreational fishers can be instrumental in successful fisheries conservation ([7], [14], [15]).

Measures are needed for the planning and management of fisheries (applicable to leisure and commercial fishing). They should be implemented in an integrated and consistent way, based on scientific and credible studies.

## 6. Acknowledgements

Sérgio Ferreira and José Nazaré for the English proofreading and editing services.

## 7. References

- [1] IUCN, 17th General Assembly (1988) <https://portals.iucn.org/library/efiles/documents/GA-17th-011.pdf>.
- [2] McCay BJ, Jones PJS. Marine protected areas and the governance of marine ecosystems and fisheries. *Conservation Biology*; 2011, 25: 1130–1133.
- [3] Jones PJS, De Santo EM, Qiu W, Vestergaard O. Introduction: An empirical framework for deconstructing the realities of governing marine protected areas. *Marine Policy*; 2013, 41 1 - 4. doi:10.1016/j.marpol.2012.12.025
- [4] Ferreira A, Seixas S, Marques J. Bottom-up management approach to coastal marine protected areas in Portugal, *Ocean & Coastal Management*; 2015 *in press*. <http://dx.doi.org/10.1016/j.ocecoaman.2015.05.008>
- [5] Oyanedel R, Marín A, Castilla JC, Gelcich S. Establishing marine protected areas through bottom-up processes: insights from two contrasting initiatives in Chile, *Aquatic Conservation, Marine and Freshwater Ecosystems*; 2015: *in press*. doi: 10.1002/aqc.2546.
- [6] Gaymer C, Stadel A, Ban N, Cárcamo P, Ierna J, Lieberknecht L. Merging top-down and bottom-up approaches in marine protected areas planning: experiences from around the globe, *Aquatic Conservation: Marine and Freshwater Ecosystems*; 2014, 24: 128–144. S2 DOI:10.1002/aqc.2508.
- [7] Granek EF, Madin EP, Brown MA, Figueira WW, Cameron DS, Hogan ZZ, Arlinghaus RR. Engaging Recreational Fishers in Management and Conservation: Global Case Studies. *Conservation Biology*; 2008: 22(5),1125-1134.
- [8] Veiga P, Ribeiro J, Gonçalves JMS, Erzini K. 2010. Quantifying recreational shore angling catch and harvest in southern Portugal (north-east Atlantic Ocean): implications for conservation and integrated fisheries management. *Journal of fish biology*, 76: 2216–2237.
- [9] Suman D, Shivilani M, Milon J. Perceptions and attitudes regarding marine reserves: a

comparison of stakeholder groups in the Florida Keys National Marine Sanctuary, *Ocean & Coastal Management*; 1999: 42 (12), 1019-1040.  
[http://dx.doi.org/10.1016/S0964-5691\(99\)00062-9](http://dx.doi.org/10.1016/S0964-5691(99)00062-9).

- [10] Shirley J. Fiske, Sociocultural aspects of establishing marine protected areas, *Ocean & Coastal Management*, Volume 17, Issue 1, 1992, Pages 25-46, ISSN 0964-5691, [http://dx.doi.org/10.1016/0964-5691\(92\)90060-X](http://dx.doi.org/10.1016/0964-5691(92)90060-X).
- [11] Charles A, Wilson L. 2009. Human dimensions of Marine Protected Areas. – *ICES Journal of Marine Science*, 66: 6–15.
- [12] Fujitani ML, Fenichel EP, Torre J and Gerber L, 2012, Implementation of a marine reserve has a rapid but short-lived effect on recreational angler use. *Ecological Applications* 22 (2): 597–605.
- [13] Lloret J, Zaragoza N, Caballero D, Riera V. 2008. Biological and socioeconomic implications of recreational boat fishing for the management of fishery resources in the marine reserve of Cap de Creus (NW Mediterranean) *Fisheries Research* 91 (2–3): 252–259.
- [14] Lynch T. 2006. Incorporation of Recreational Fishing Effort into Design of Marine Protected Areas *Conservation Biology* 20(5):1466-1476. DOI: 0.1111/j.1523-1739.2006.00509.x
- [15] Alós J, Arlinghaus R. 2013. Impacts of partial marine protected areas on coastal fish communities exploited by recreational angling *ICES Journal of Marine Science* 137: 88–96.
- 
-



## What Happens When Water Evaporates? An Inquiry Activity with Primary School Children

*P Varela, F Serra, MFM Costa*  
*University of Minho, Portugal*  
*pibvarela@ie.uminho.pt,*  
*filipaserra\_89@hotmail.com,*  
*mfcosta@fisica.uminho.pt*

**Abstract.** This paper is the result of a pedagogical intervention project carried out in a primary school. The intervention took place in a 4th grade class (n=24) and involved an inquiry-based approach to the teaching of the curricular topic “water phase changes”.

The project employed an action research methodology whose main goals were: a) to promote inquiry-based science teaching; b) to describe and analyse the process of the construction of meanings in relation to the phenomena under study, and c) to evaluate the learning acquired by the students. At the end of each lesson, a class diary was prepared - a descriptive and reflective narrative compiled from the field notes and audio recordings made during participant observation in the classroom. It was one of these class diaries that served as basis for this article, which describes and analyses the process of scientific meaning construction occurred in the classroom, around the phenomenon of “water evaporation”.

The results of the assessment on the learning acquired show that the vast majority of students developed an atomistic model to explain the phenomenon of water evaporation, in which liquid water turns into small, invisible particles (water vapour), which become part of the air around us. This model is consistent with the notion of conservation of matter.

**Keywords.** Inquiry-based science teaching, water evaporation, elementary science.

### 1. Introduction

Very early on, children manifest a natural curiosity and interest in knowing and making sense of the world that surrounds them. The teaching of sciences should take advantage and enhance these natural qualities in children, as they constitute the necessary support for active and meaningful learning in the classroom [1, 2, 3]. The goal is to “educate” the children’s

natural curiosity in order to develop more systematic, deeper and more autonomous thinking patterns [4]; stimulate them to pose questions and look for possible answers for what they do and see; enable them to devise ways to test their ideas and thought strategies; to share and discuss their own theories and explanations with others [5, 2]. Unfortunately, the traditional educational system works in a way that generally discourages the natural process of inquiry. Thus, the meaningful exploration of inquiry-based science activities stands as a privileged means to convert classrooms into places of leisure, satisfaction and personal fulfilment, as they allow the creation of a learning environment where children learn and do things they really enjoy [3, 6]. A stimulating and challenging learning environment, which can be provided by exploring inquiry activities, is essential for the children's social and intellectual development [7, 8, 9].

Inquiry-based science education in the early years of schooling is, therefore, vital to help the children: understand the world around them; learn to obtain and organise information; develop ways to discover; test ideas and use evidence; and develop positive attitudes towards science [2, 10]. On the other hand, it can also help children develop very different thinking skills early on [11], e.g., scientific thought, critical thinking, autonomous problem solving and meta-cognitive skills, which are likely to be transferred and applied to other contexts and learning situations [7, 8]. Finally, we could say that inquiry activities in science classes also offer a privileged setting for the use and development of other fields of knowledge, specifically oral and written language and mathematics [2, 3]. Science education is, therefore, of great importance for children, as it promotes the development of processes, concepts and basic attitudes that will be indispensable for subsequent scientific learning [2, 10].

The importance of science for children has been widely recognised in the science curriculum guidelines of many countries, which, like some international organisations, have also recommended inquiry methods for its approach. However, in the majority of European countries, the reality of classroom practice is that these methods are being implemented by relatively few teachers [12, 13].

## 2. The students' intuitive ideas and the understanding of water evaporation

A study conducted by Russell, Harlen and Watt [14], showed that children have intuitive conceptions about the evaporation of water, which can be grouped into three categories: a) there is no conservation of the quantity of water. Evaporated water simply ceases to exist; b) there is a change in location without transformation of the water; c) there is a change in the location of the water with transformation into in a visible or invisible form. It should be noted that atmospheric air is almost never referred to as the place where evaporated water goes.

Bar and Galili [15] state that the conceptual change of views regarding evaporation in children's minds shows a clear correlation with their cognitive development, namely the use of the conservation principle and the adoption of an abstract model for air. Children's conceptions of evaporation could be categorised into one of four age-related views, as follows: (1) the water disappears (age 5-6); (2) the water penetrates solid objects (7-8); (3) the water evaporates into some "container" (9-10); or, (4) the water evaporates, it is scattered in the air (age 10-11).

The understanding of the evaporation phenomenon by students requires the ability of abstraction: liquid water, which they can see and feel, turns into water vapour, a material body made up of tiny particles, which they cannot see or feel. According to Sá [3], there are four aspects to consider in the development of the concept of evaporation in children: a) the concept of conservation of matter, despite the transformation occurred: the water continues to exist despite no longer being visible; b) the change of location of the evaporated water. Where does the water go?; c) the conditions or factors that influence the evaporation rate; d) the nature of the transformation that the water undergoes during the evaporation process.

Often, when children approach the concept of evaporation, through the activity of observing the amount of water in a container decrease when in contact with air, their idea of evaporation is limited to the context in which the liquid has a surface in contact with air. Consequently they will be able to apply that notion to ponds, rivers and oceans, but they will be unable to explain the drying of clothes or the

transformation of mud into hard, parched earth through evaporation. The drying of clothes and the evaporation of water from a cup are seen by children as different phenomena [3]. This means that the development of a concept or idea requires the diversification of activities, i.e. different science education contexts where the same phenomenon occurs [2].

## 3. Objectives

A pedagogical intervention project was developed, with the aim of promoting an inquiry-based science teaching practice in the approach to the curricular topic "water phase changes". For that purpose, several lessons were planned and implemented in the classroom. Thus, the specific objectives of this paper are: a) to describe and analyse the teaching and learning process promoted in the classroom during the exploration of one of these lessons, and b) to assess the learning acquired by the children.

## 4. Methodology

The science teaching project adopted an action research methodology and was carried out with a class of the 4th year in a Portuguese primary school, located in the city of Famalicão.

The class was composed of 24 students, 13 boys and 11 girls, aged between 9 and 10 years. For two months, 5 lessons were taught on the curricular topic "Water phase changes", amounting to a total of 10 hours of intervention in the classroom, as presented in the table 1.

For each topic addressed, a teaching and learning plan was prepared, containing the following elements: i) learning goals; ii) materials needed for the groups to carry out the planned activities; iii) guidelines for the teaching and learning process; and iv) an individual record sheet for each student.

Each lesson, which corresponds to one action research cycle, begins with a teaching and learning plan, which is implemented flexibly, according to the teaching and learning processes generated and promoted within the reality of the classroom. The lessons were taught by the second author of this paper, who, in collaboration with the class teacher, played the role of both researcher and teacher.

Lesson subject	Duration
Solid, liquid and gaseous materials: What are the differences?	2h 00m
Fusion and solidification of water	2h 00m
Water evaporation	2h 30m
Condensation	2h 00m
The water cycle	1h 30m
Total	10h 00m

**Table 1. Lesson subject and duration**

The data generated in this intervention was collected using two complementary methods: the field notes made by the researchers and the audio recordings of the lessons. This raw data was subsequently compiled in the form of detailed narratives that include the most relevant events that took place in the classroom – the class diaries. These constituted the main method of recording data and, simultaneously, a strategy for reflection and for the modelling of the teaching and learning process [16]. This paper aims at describing and analysing the teaching and learning process promoted in the classroom, based on the class diary about water evaporation.

With the purpose of assessing the learning acquired by the children, a questionnaire was prepared and administered three weeks after the pedagogical intervention.

## 5. Results

### 5.1. Class diary content analysis

In small collaborative groups, the students investigate water evaporation, in terms of the variation in the amount of water occurred after a few days in an uncovered cup, in a cup with wet earth and in a wet cloth. The lesson begins with the following question:

#### **A. What will happen to the water in this cup if we leave it uncovered for a few days?**

- A<sub>1</sub>. The students make predictions.

Their answers suggest that the water will evaporate: "the water will evaporate" (Rodrigo); "it will evaporate" (Ana); "it will evaporate because it will be in the cup for

many days" (Catarina). However, when asked if the amount of water in the uncovered cup will be the same after a few days, opinions are divided: some argue that yes, while others believe that the amount will be different.

- A<sub>2</sub>. The students discuss the different predictions. Excerpt from the class diary:

"I think it will evaporate and no water will be left" (Ana). "The cup will have less water, because of the sun, which will turn the water into the gaseous state" (Rodrigo). "The water will evaporate because of the heat in the room" (António). "It will disappear, but very slowly, because of the sun and the temperature of the room" (Afonso).

After the collective reflection and discussion, it appears that: a) there are more and better arguments in favour of a reduction in the amount of water in the uncovered cup, due to the fact that it is subject to the phenomenon of evaporation; b) there are those who justify their opinion based on the water passing from the liquid to the gaseous state. The sun and the heat of the room are seen as the agents of this phase change; c) there are those who use the term "disappear", which could mean that the evaporated water ceases to exist - absence of the notion of conservation.

- A<sub>3</sub>. The students record their predictions.

Most children (22; 91.6%) predict that the amount of water in the uncovered cup will be smaller after a few days. Only two children (2; 8.4%) wrote on their record sheet that the amount of water will remain the same.

#### **B. How can we find out who is right? Planning a strategy to test the predictions.**

- B<sub>1</sub>. The students reflect and negotiate the best way to test their predictions.

"We can take the cup with water and draw a small line on it. Then, on Monday, we'll see if the water is still at that line" (João A.). Rodrigo suggests a different idea: "weighing the water; then, we would weigh it again and see if the weight was the same". When asked to give their opinion on these ideas, the class is unanimous in considering Rodrigo's idea the best. In an effort to preview the results,

students state that the amount of water will decrease in terms of weight variation: "the water will lose weight because, as it evaporates, it will lose the weight of the water lost in those days" (João L.). Children who previously said the weight would remain the same are now unable to find a plausible explanation.

- B<sub>2</sub>. The children build a rudimentary scale. Excerpt from the class diary:

"How can we measure the amount of water evaporated if we do not have a scale?" – I asked. In the absence of answers, I give them some tips to build a scale with two empty yoghurt cups, a small plastic rod and a piece of string. With my help, the groups build their scales and make a few comments: "The cup that goes up is the lighter one" (Rúben). "The heavier cup goes down" (Inês).

- B<sub>3</sub>. The students plan out procedures to balance the scales:
  - After the construction.

"Now, how will we balance the scales?" – I ask. "The cups have to be in the same position" (Fábio). "The stick has to be straight" (Sérgio). Given their difficulties, I help the groups to balance their scales.

It is difficult to balance the scale when the two cups are suspended, because of the length differences that may exist in the strings that support them. The scales are balanced by positioning the plastic rod horizontally, through the following procedures: a) the students move the string tied at the middle of the plastic rod to the left or to the right; b) or they move the strings tied to each end of the plastic rod to the left or to the right, depending on the imbalance.

- After water is put into one of the cups.

"What should we do now to find out the amount of water that evaporated?" "We have to put water" (Luísa). "We put water in one of the cups and something else in the other cup, until the scale is straight". "What "other thing" will we put in the other cup?" – I ask. In the absence of any answers, I pick up a handful of beans and, immediately, Sérgio says: "We put in an amount of water and then we put beans in the other cup until the scale is straight (balanced)".

### **C. Now, what will happen to a wet cloth and a bit of moist earth?**

- They apply the previous knowledge to the new contexts.

"It will dry out" (Ana). "The weight will decrease because the cloth will dry out and then it will no longer have as much water" (Mariana). "The water evaporates and then the cloth gets lighter" (Inês). "And what will happen after a few days, if we put this wet earth into a cup as well?" "The scale will be tilted because water has weight and, as it evaporates, it will get lighter" (João A.). "The water will evaporate and the cup with the earth will be lighter" (Luísa).



**Figure 1. The groups balance their scales**

It is relatively easy for students to mobilise and apply the previous knowledge to new contexts. Throughout this process, it should be noted that: i) the predictions about what will happen to the wet cloth and the wet earth, unlike what was previously found for the cup with water, are now converging towards the fact that the amount of water will decrease after a few days; ii) the variations in the amount of water that will occur in both contexts, due to the process of evaporation, are now referred to in terms of weight variation.

### **D. How can we find out if the amount of water will decrease in all three cases?**

- The students perform the procedures.

With my help, each group performs one of the following balances of the scale: water/beans, wet earth/beans, damp cloth/beans. I interact with the groups and ask if the scale is balanced. "The cup with water still outweighs the other" (Inês), "What do you need to do?" – I ask. "Put in more beans" (Ana). "Put less water" (Maria). They remove some of the water from the cup and some of the elements of the group say: "It's not there yet"; "Now it's equal"

(Rúben); "now it's balanced" (several). With my help, the balanced scales are suspended from a rope in a corner of the classroom.

**E. What differences do you see in the scales since the last lesson?**

- The students interpret their observations.

On Monday morning, after three days, I ask: "What differences do you see in the scales?" "They are tilted" (António). "The water evaporated" (Margarida). "Why did that happen?" "Because the beans in the cups did not evaporate and then, as the water evaporated, they became heavier" (Ana). "The heavier cups are lower" (Rúben). "The water evaporated from all the cups" (Fábio). "In the cups with the cloth and the wet earth, water also evaporated and they got lighter" (Inês).

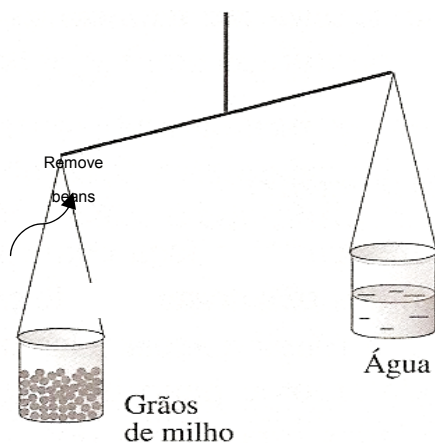

**Figure 2. Procedure 1: water/beans.**

**F. How can we measure the amount of water that evaporated?**

- F<sub>1</sub>. The children suggest a procedure.

Students show that they understand that the amount of evaporated water can be obtained by re-balancing the scales. They suggest removing beans from the heavier cups (which are lower), until they obtain a new balance: "removing beans" (Rodrigo); "the beans that we remove are the weight" (Rúben); "that is the weight of the water that evaporated" (Margarida).

The figure 2 illustrates the procedure suggested by the students:

- F<sub>2</sub>. They reflect on a possible unit of measure.

"Is it possible, then, to use the beans as a unit of measure?" – I ask. "Yes, the beans we remove are how much it weighs" (Rúben). "That is the weight of the water that evaporated" (Inês). One of the groups removes and counts beans from one of the scales, until it is balanced. "So, the water that evaporated corresponds to how many beans?" "Twenty-three" - they answer. "By removing the beans, the scale got straight" (Inês). "The beans are the weight of the water that evaporated" (Fábio). "By removing the beans, we learn the amount of water that evaporated in beans" (Nuno).

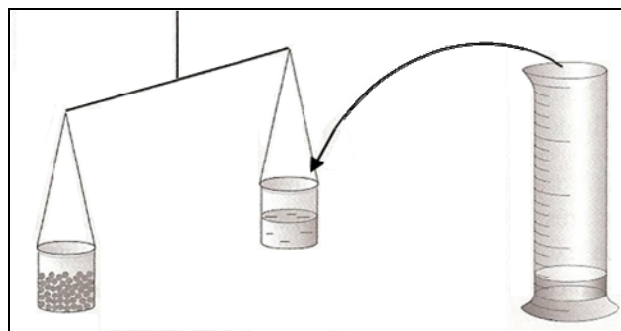

**Figure 3. Procedure 2: water/beans**

- F<sub>3</sub>. They measure the water that evaporated in ml.

I encourage the students to think about another procedure to measure the amount of water that evaporated in the three situations (cup with water, cup with wet earth and cup with wet cloth). "Put in more water and measure" (Mara). "Measure the water that the cups have" (Tiago). "What will we use to measure?" – I ask. "We'll have to use a measuring cup" (Rúben). I give Rúben a beaker. I put 80 ml of water in the beaker. In the scale built by his group, and with the help of his classmates, he pours water until the scale is balanced. I ask to see how much water was left in the beaker. He replies that 68 ml were left. "What is the amount of water that evaporated?" "The amount evaporated was 12 ml. We calculate



the difference" (Jorge). The groups perform the same procedure to measure the amount of water evaporated in the remaining situations and find out it is different: 8 ml in the cup with wet earth and 10 ml in the cup with the wet cloth.

- F<sub>4</sub>. They record the data in a table.

By way of illustration, the following is the type of record made by the students in their record sheet.

Balanças	V. inicial	V. final	Água evaporada (ml)
A. Com água	80 ml	68 ml	12 ml
B. Com terra húmida	80 ml	72 ml	8 ml
C. Com pano molhado	80 ml	70 ml	10 ml

Figure 4. Example of a record sheet (in portuguese).

The results obtained are consistent with the predictions originally made by all the groups - water evaporation in the three contexts.

### G. Where did the water that evaporated go?

- Collective reflection and discussion.

"It went to the sky" (Ana). "To the clouds" (João A.). "It went outside. The water went outside. Clouds can't form in here" (Mafalda). "When water evaporates, it goes up" (Nuno). "Does the water that evaporates go immediately up to form clouds?" - I ask. Tentatively, some say "no" and Nuno intervenes: "When we heat water on the stove, we see the water coming out and the extractor hood gets wet". "So where did the evaporated water go?" "It went into the air" (Jorge). "It spread throughout the air" (António). "Then what exists in the air?" "Water" - Inês promptly answers. "In what state is that water that evaporated?" - I ask. "In the gaseous state" (Rúben). "It must turn into tiny droplets, but we cannot see them" (Nuno). So what happens to water in things when they dry? "It goes into the air, all around us" (several students). "Water turns into "little things" that we cannot see, but that are there" (Rodrigo). "They stay in the air" (Margarida).



Figure 5. Example of a drawing made by one of the students

During the collective reflection and discussion, when students are asked where the evaporated water has gone, explanations of different conceptual levels arise:

- One argues that the evaporated water - water vapour - goes directly to the clouds. This is an intuitive notion that, if accepted, does not even include a phase change, as in the clouds, water is in the liquid state.
- Another expresses the idea that water vapour is now in the air, the students failing, however, to suggest a more explanatory theory.
- Lastly, a third one reveals an atomistic concept of evaporated water, which is consistent with the concept of conservation. In this theory, evaporated water does not cease to exist, but merely undergoes a change in physical state, now taking the form of small, invisible particles: "water turns into "tiny things" that cannot be seen, but that are there". This notion is present in some of the drawings made by the students at the end of the lesson.



## 5.2. Assessment of learning

Three weeks after the lessons, the following question was included in an assessment test:

Mark the correct sentence with a cross (X):

- a) The water in the cups disappeared and ceased to exist.
- b) The water disappeared and went straight to the clouds.
- c) The water is now in the air, in small particles that cannot be seen.

In the graph of figure 6 it is shown the relative and absolute frequency distribution of the student's answers.

It was found that a vast majority (71%) of students developed an atomistic model to explain the phenomenon of water evaporation, in which liquid water turns into small, invisible particles (water vapour), which move around and are carried by the air that exists all around us. This model is consistent with the concept of conservation of matter – only one child marked sentence (a) as correct.

## 6. Final considerations

The data contained in the class diary takes on the nature of a sample of the learning acquired by the children, not allowing for any illations about the degree of individual learning achieved by each one. However, the combination of that learning with the data obtained on the items of the individual assessment question shows that most of the children in the class, in order to explain water evaporation, developed a model in which liquid water turns into small, invisible particles – water vapour –, which move around and are carried by the air around us. This model is consistent with the notion of conservation of matter.

According to Coll and Martín [17], an evaluation that is based on the consideration of an instant situation is unreliable, as it fails to take into account the dynamic nature of the meaning construction process, as well as its temporal dimension. In this regard, the results obtained in the items of the assessment question, three weeks after the lesson, also allow claiming that this learning was significant, as opposed to memorisation, which is quickly forgotten.

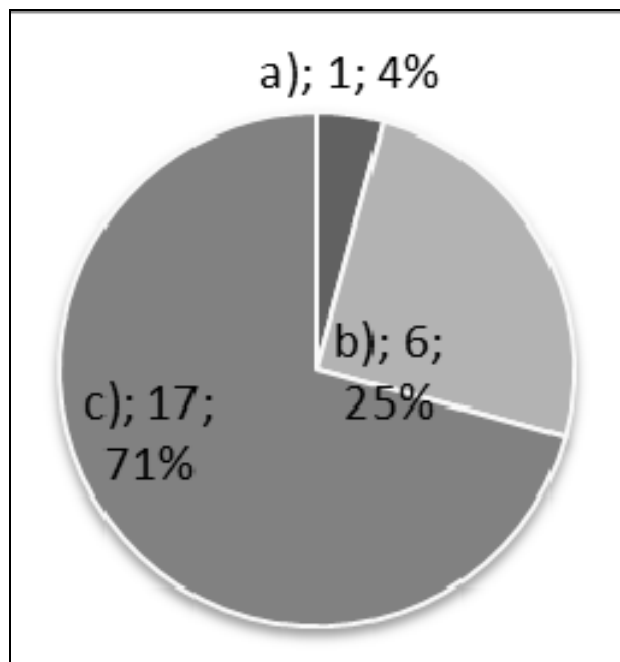

Figure 6. Students' answers

The teaching and learning process analysed above, on water evaporation, entails great personal and intellectual involvement by the children and is closely dependent on an intervention intentionally guided by the teacher, which aims at promoting in them both the construction of meanings that are more consistent with reality and the development of scientific process skills. In this sense, the teacher plays a key role. The teacher, through a process of questioning that stimulates the children's thoughts and actions [3], supports their individual and collective cognitive activity [18,19]. Through this process of questioning [19] guided by the teacher, students are able to reach higher levels of comprehension and, simultaneously, develop better thinking skills, which they would not be able to achieve without support.

Lastly, we would like to point out that the initial and in-service training of primary school teachers should be able to endow them not only with scientific knowledge, but also with specific didactic knowledge on how to explore the different curricular topics with the children. The development of this knowledge should be based on the data and tools that emerge from research undertaken with children in the classroom context. Research in science education should offer fruitful elements to support the educative action of the teachers. In this sense, the analysis presented in this article, about the activity "water evaporation"

may constitute both a didactic resource for teacher training and an element of support for those teachers, so that, in similar contexts, they are able to promote the same teaching and learning process with their students.

## 7. References

- [1] Duschl RA, Schweingruber HA, Shouse AW. Taking science to school: Learning and teaching science in grades K-8. Washington, DC: National Academy Press; 2007.
- [2] Harlen W. Enseñanza y aprendizaje de las ciencias (2ª ed. atualizada). Madrid: Ediciones Morata; 2007.
- [3] Sá JG. Renovar as Práticas no 1º Ciclo Pela Via das Ciências da Natureza. Porto: Porto Editora; 2002.
- [4] Furman M. O Ensino de Ciências no Ensino Fundamental: colocando as pedras fundacionais do pensamento científico. Vila Siqueira: Sangari Brasil; 2009.
- [5] Varela P. Experimental Science Teaching in Primary School: Reflective Construction of Meanings and Promotion of Transversal Skills. Saarbrücken, German: Lap Lambert Academic Publishing; 2012.
- [6] Charpack G. As Ciências na Escola Primária: Uma Proposta de Acção." Mem Martins: Editorial Inquérito; 2005.
- [7] Dyasi HM. What children gain by learning through inquiry. In: Rankin I. Ed., Inquiry: Thoughts, Views and Strategies for the K-5 Classroom. Arlington: National Science Foundation; 1999, p. 9-13.
- [8] Dyasi HM. Visions of Inquiry Science. In: Douglas R. et al., Ed. Linking Science & Literacy in the K-8 Classroom. Arlington: NSTA Press; 2006, p. 3-16.
- [9] Jensen E. O cérebro, a bioquímica e as aprendizagens: Um guia para pais e educadores. Lisboa: Edições ASA; 2002.
- [10] Eshach H, Fried M. Should science be taught in early childhood? Journal of Science Education and Technology 2005, 14(3): 315-336.
- [11] Cuevas P, Lee O, Hart J, Deaktor R. Improving Science Inquiry with Elementary Students of Diverse Backgrounds. Journal of Research in Science Teaching 2005, 42(3): 337-357.
- [12] Abd-El-Khalick F, Baujaoude S, Duschl R, Lederman NG, Mamlok-Naaman R, Hofstein A. Inquiry in science education: International perspectives. Science Education 2004, 88(3), p. 397-419.
- [13] Kask K, Rannikmäe M. Towards a model describing student learning related to inquiry based experimental work linked to everyday situations. Journal of Science Education 2009;10(1):15-19.
- [14] Russell T, Harlen W, Watt D. Children's ideas about evaporation. International Journal of Science Education 1989, 11(5): 566-576.
- [15] Bar V, Galili I. Stages of children's views about evaporation. International Journal of Science Education 1994, 16(2), 157-174.
- [16] Zabalza MA. Diarios de clase: un instrumento de investigación. Madrid: Narcea; 2004.
- [17] Coll C, Martín E. A avaliação da aprendizagem no currículo escolar: uma perspectiva construtivista. In: Coll C. et al.; O construtivismo na sala de aula. Novas perspectivas para a acção pedagógica. Porto, Edições ASA; 2001, p 196-221.
- [18] Chin C. Classroom Interaction in Science: Teacher questioning and feedback to students' responses. International Journal of Science Education 2006, 28(1), 1315-1346.
- [19] Kawalkar A, Vijapurkar J. Scaffolding Science Talk: The role of teachers' questions in the inquiry classroom. International Journal of Science Education 2013, 35(12), 2004-2027.
- 
- 
-

## Exploring Probability Distributions with the Softwares R and Excel

*D Gouveia-Reis, S Mendonça*  
*Universidade da Madeira, Portugal*  
*delia@uma.pt, smfm@uma.pt*

**Abstract.** Statistics has an important role in many areas of knowledge like Psychology and Nursing, among many other areas. One topic of particular interest is the use of probability distribution functions, being the calculation of the corresponding probabilities and quantiles a teaching challenge in areas where students do not have a deep mathematical background. In this situation, visualizing and interpreting the probability distribution functions become a crucial point in the learning process. This work suggests the use of softwares as R and Excel in the visualization of probability distribution functions and in the determination of its corresponding probabilities and quantiles.

**Keywords.** Distribution functions, Excel, quantiles, software R.

### 1. Introduction

The advance of knowledge in Psychology and Nursing, among many other areas, is based on empirical evidence obtained by the scientific method of observation and experimentation. One of the steps of this scientific method is the gathering of relevant information and its analysis. Sometimes the nature of the data suggests the form of a probability model, but at other times the appropriate probability model will not be readily apparent. Either way, the formulation of a probability model to describe the data requires some knowledge about random variables. This work is a contribution to the exploration of the most popular random variables, namely, the normal, the chi-square, the Student's  $t$  and Fisher-Snedecor's  $F$  distributed ones.

### 2. Some special random variables

Random variables are modeling tools. It is very common to quantify what surrounds us by simplifying complex situations to simple counts of individuals who have some particular characteristic, or to the act of measuring certain characteristics. The importance of the Gaussian or normal model and the role of chi-square, Student's  $t$  (in short,  $t$ ) and Fisher-

Snedecor's  $F$  (in short,  $F$ ) distributions on statistical inference gives these models a central place in introductory probability and statistics courses.

A random variable  $X$  is said to be normally distributed with mean  $\mu \in \mathbf{R}$  and standard deviation  $\sigma > 0$  (in short,  $X \sim \text{Normal}(\mu, \sigma)$ ), if its probability density function (pdf) is given by (1):

$$f(x) = \frac{1}{\sqrt{2\pi}\sigma} \exp\left(-\frac{(x-\mu)^2}{2\sigma^2}\right), x \in \mathbf{R}. \quad (1)$$

The chi-square, the  $t$  and the  $F$  distributions result from certain combinations of normal distributed random variables.

If  $Z_1, \dots, Z_n$  are independent standard normal random variables (meaning that for all variables considered,  $\mu = 0$  and  $\sigma = 1$ ), then the random variable  $X$ , defined by (2)

$$X = Z_1^2 + \dots + Z_n^2 \quad (2)$$

is said to have a chi-square distribution with  $n \in \mathbf{N}_1$  degrees of freedom (in short,  $X \sim \chi_n^2$ ). Unlike the normal distributed random variable, the chi-square distributed distribution is not symmetric and its values cannot be negative. Its pdf, for  $x > 0$ , is given by

$$f(x) = \frac{x^{\frac{n}{2}-1} \exp\left(-\frac{x}{2}\right)}{\Gamma\left(\frac{n}{2}\right) 2^{\frac{n}{2}}}, \quad (3)$$

(where  $\Gamma$  stands for the gamma function) and, for  $x \leq 0$ ,  $f(x) = 0$ .

The random variable  $T$  defined by (4)

$$T = \frac{Z}{\sqrt{X/n}}, \quad (4)$$

with  $Z \sim \text{Normal}(0, 1)$  and  $X \sim \chi_n^2$ , independent from  $Z$ , has a  $t$ -distribution with  $n$  degrees of freedom. Its pdf, for  $x \in \mathbf{R}$ , is given by (5)

$$f(x) = \frac{\Gamma\left(\frac{n+1}{2}\right)}{\Gamma\left(\frac{n}{2}\right)\sqrt{n\pi}} \left(1 + \frac{x^2}{n}\right)^{-\frac{n+1}{2}}. \quad (5)$$

If  $X \sim \chi_m^2$  and  $Y \sim \chi_n^2$  are independent chi-square distributed random variables with  $m$  and  $n$  degrees of freedom, respectively, then the random variable  $F$  defined by (6)

$$F = \frac{X}{m} / \frac{Y}{n} \quad (6)$$

is said to have an  $F$ -distribution with  $m$  and  $n$  degrees of freedom (in short,  $F \sim F_{m,n}$ ) and has a pdf given by (7), for  $x > 0$ ,

$$f(x) = C \left(\frac{m}{n}x\right)^{\frac{m}{2}-1} \left(1 + \frac{m}{n}x\right)^{-\frac{m+n}{2}}, \quad (7)$$

where  $C = \frac{\Gamma((m+n)/2)}{\Gamma(m/2)\Gamma(n/2)} \left(\frac{m}{n}\right)$ . For  $x \leq 0$ ,

$f(x) = 0$ .

For more information about these random variables cf., eg., [1], [2] and [3].

### 3. Visualizing distributions

Microsoft Excel software (in short, Excel) is a spreadsheet application widely available. Although not being a statistical package, it contains some basic statistic functions and data analysis tools, that can be used to teach, learn and explore statistical concepts. It is a didactic tool, with an embedded programming language, the Visual Basic for Application (known as VBA) that allows to automate some procedures and to extend its potentialities.

Excel software has a list of several continuous distribution functions ready to be used. Among these are the ones associated with chi-square (CHIDIST; CHIINV),  $F$  (FDIST; FINV), normal (NORMDIST; NORMINV; NORMSDIST; NORMSINV) and  $t$  (TDIST; TINV) distributions. For example, the instruction `NORMDIST(x, μ, σ, FALSE)` gives the probability density function value  $f(x)$  for  $X \sim \text{Normal}(\mu, \sigma)$  and the instruction `NORMDIST(x, μ, σ, TRUE)` gives the

cumulative probability distribution value  $F(x)$  for the same random variable. (The explanation of the other Excel functions can be found in its *Help* facility. The above list of function names was extracted from the *Built-in Statistical Functions* of 2007 version of Excel. New functions were added to later versions of Excel (2010 and 2013), and some new naming conventions have been introduced.) Using these functions in conjunction with the `If` instruction and the graphical representation (*chart type Area*) it is possible to obtain a visual representation of the areas that correspond to the probabilities that are looked for. (Please note that the present work is not affiliated with, nor has it been authorized, sponsored, or otherwise approved by Microsoft Corporation.)

R is a free software environment for statistical computing and graphics which is a product of a collaborative effort with contributions from all over the world [4]. Within the many packages of R, our choice was to apply the package *mosaic*. This package was created by a community of educators interested in introducing mathematics, statistics and computation to students.

The package *mosaic* includes the function `pdist` that computes and illustrates the cumulative probabilities for the most common distributions, which are identified by the first argument of the mentioned function. Among these are the standard normal (*norm*), the chi-square (*chisq*), the  $t$  (*t*) and the  $F$  (*f*) distributions. The vector of values whose images are to be computed and the number of degrees of freedom (for the chi-square and  $t$  distributions: *df*; for the  $F$  distribution: *df1* and *df2*) follow this identification.

The probabilities and graphs related to the general normal distribution are obtained with the function `xpnorm`. This function returns a similar output as the function `pdist`, but presents additionally the conversion to the standard normal distribution scores. The first argument of the function `xpnorm` is a vector of values whose images are to be computed, followed by the values of the mean (*mean*) and standard deviation (*sd*).

Analogously, the package *mosaic* contains two functions `qdist` and `xqnorm` which compute and illustrate quantile values, given a vector of probabilities instead of a vector of score values.

More information about the package and about each function can be found in <http://cran.project.org/web/packages/mosaic/index.html>.

The following section gathers some simple exercises which are solved by the use of the above presented commands.

#### 4. The normal distribution

Consider  $X \sim \text{Normal}(5;0.4)$ , whose pdf and cumulative distribution function are graphed in Fig. 1.

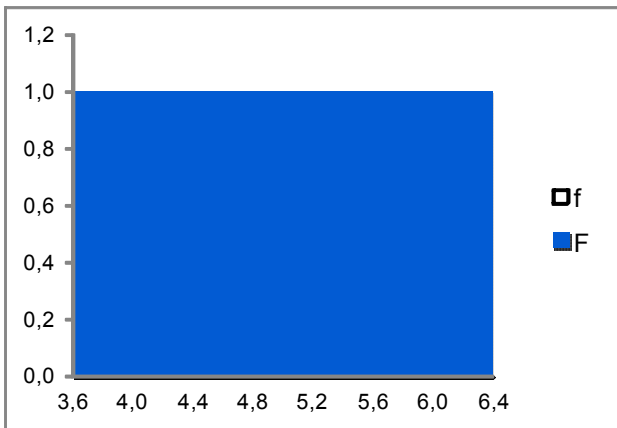

**Figure 1. Probability density (f) and cumulative distribution (F) functions of Normal(5;0.4)**

Exercise 1: Graph the pdf of  $X$  and find the probabilities  $P(X \leq 4.7)$ ,  $P(X > 5.8)$  and  $P(4.7 < X \leq 5.8)$ :

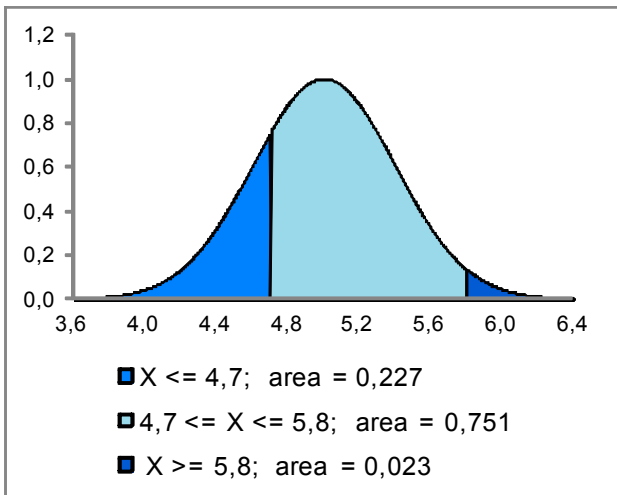

**Figure 2. Pdf of  $X \sim \text{Normal}(5;0.4)$  and probabilities computed with Excel**

```
> xpnorm(c(4.7, 5.8), mean=5, sd=0.4)

If X ~ N(5,0.4), then

P(X <= 4.7) = P(Z <= -0.75) = 0.2266
P(X <= 5.8) = P(Z <= 2) = 0.9772
P(X > 4.7) = P(Z > -0.75) = 0.7734
P(X > 5.8) = P(Z > 2) = 0.0228

[1] 0.2266274 0.9772499

> 0.9772499-0.2266274
[1] 0.7506225
```

**Figure 3. Probabilities computed with the package mosaic**

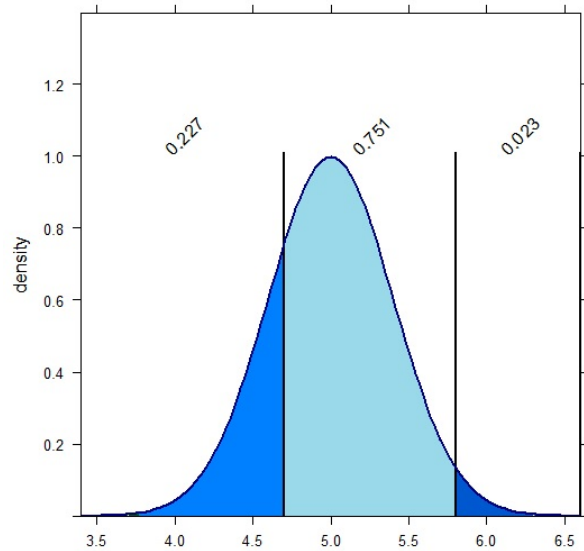

**Figure 4. Pdf of  $X \sim \text{Normal}(5;0.4)$  and probabilities computed with the package mosaic**

Exercise 2: Graph the pdf of  $X$  and find the third quartile, which is the value separating the bottom 75% from the top 25%.

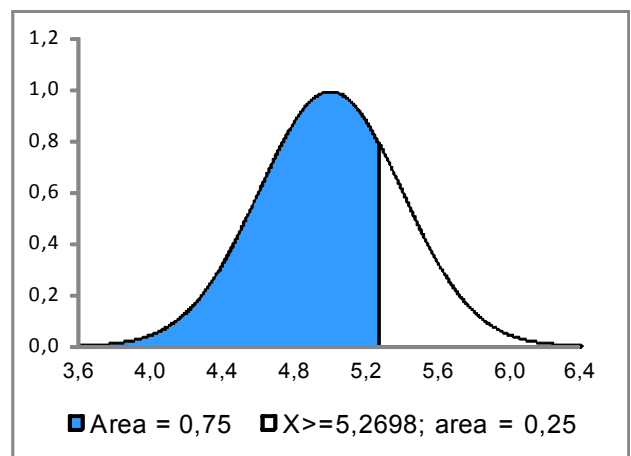

**Figure 5. Pdf of  $X \sim \text{Normal}(5;0.4)$  and quantile 0.75 computed with Excel**

```
> xqnorm(0.75,mean=5,sd=0.4)
P(X <= 5.2697959) = 0.75
P(X > 5.2697959) = 0.25

[1] 5.269796
```

Figure 6. Quantile 0.75 computed with the package *mosaic*

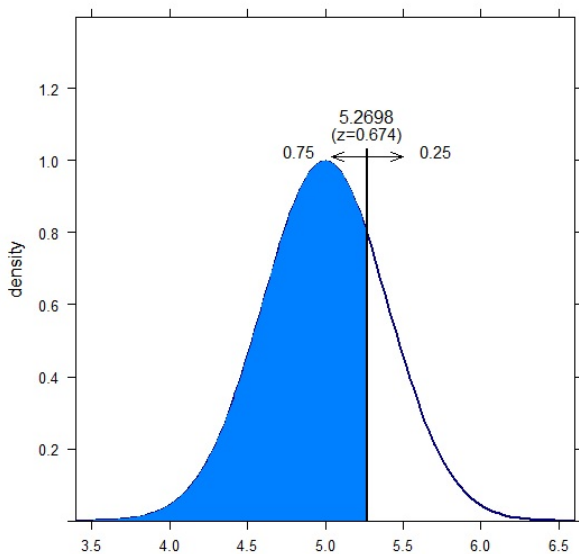

Figure 7. Pdf of  $X \sim \text{Normal}(5;0,4)$  and quantile 0.75 computed with the package *mosaic*

## 5. The chi-square distribution

Consider  $X \sim \chi_5^2$ , whose pdf and cumulative distribution function are graphed in Fig. 8.

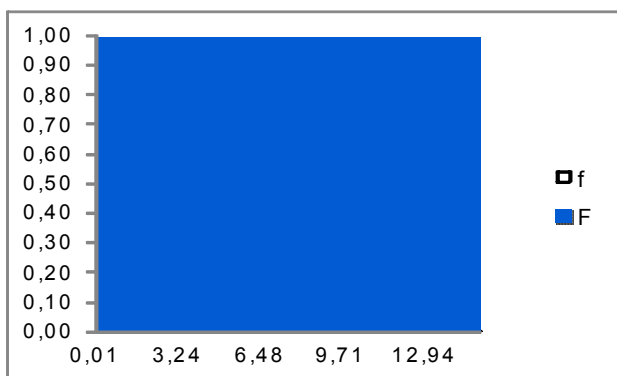

Figure 8. Probability density (f) and cumulative distribution (F) functions of  $\chi_5^2$

Exercise 1: For  $X \sim \chi_5^2$ , graph the pdf of  $X$  and find the probabilities  $P(X \leq 5)$ ,  $P(X > 9)$  and  $P(5 < X \leq 9)$ .

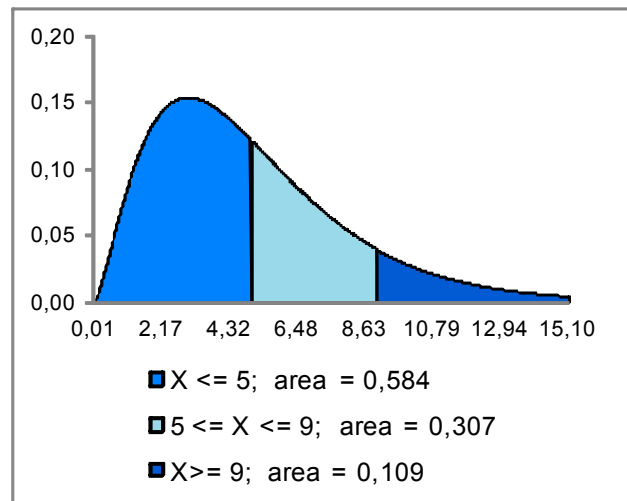

Figure 9. Pdf of  $X \sim \chi_5^2$  and probabilities computed with Excel

```
> pdist("chisq",c(5,9),df=5)
[1] 0.5841198 0.8909358

> 0.8909358-0.5841198
[1] 0.306816
```

Figure 10. Probabilities computed with the package *mosaic*

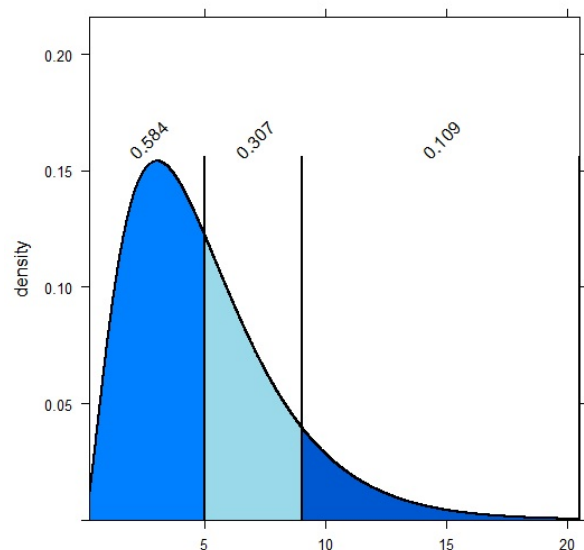

Figure 11. Pdf of  $X \sim \chi_5^2$  and probabilities computed with the package *mosaic*

Exercise 2: For  $X \sim \chi_5^2$ , graph the pdf of  $X$



and find the third decile, which is the value separating the bottom 30% from the top 70%.

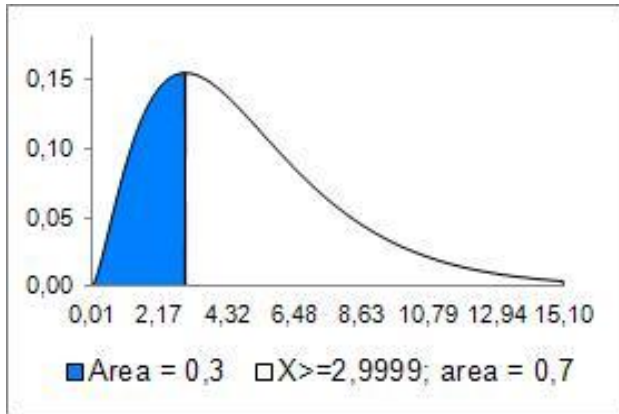

Figure 12. Pdf of  $X \sim \chi_5^2$  and quantile 0.30 computed with Excel

```
> qdlist("chisq",0.30,df=5)
[1] 2.999908
```

Figure 13. Quantile 0.30 of  $X \sim \chi_5^2$  computed with the package *mosaic*

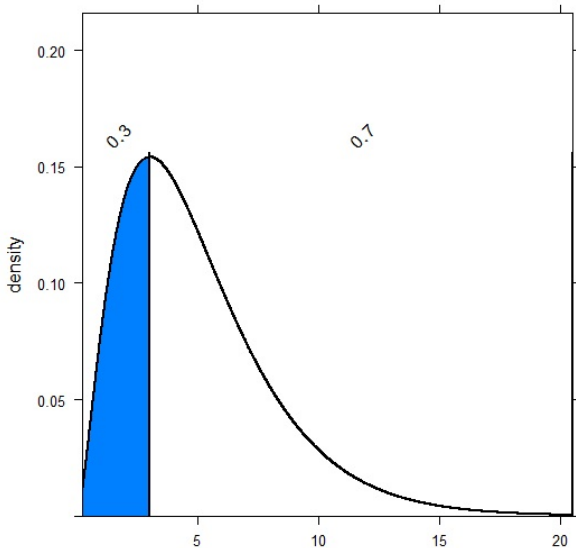

Figure 14. Pdf of  $X \sim \chi_5^2$  and quantile 0.30 computed with the package *mosaic*

## 6. The *t*-distribution

Consider  $X \sim T_{10}$ , a *t* distributed random variable with 10 degrees of freedom, whose pdf and cumulative distribution function are graphed in Fig. 15.

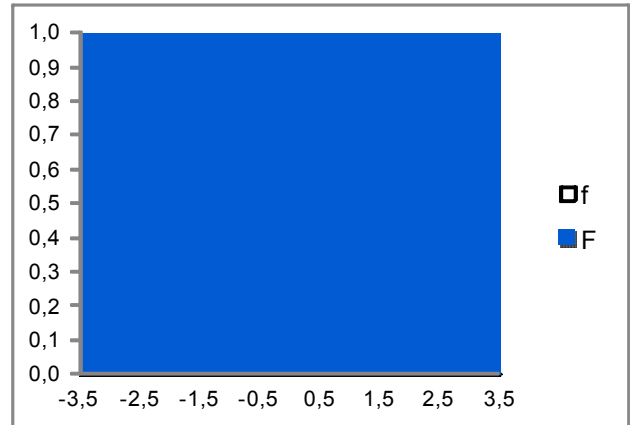

Figure 15. Probability density (*f*) and cumulative distribution (*F*) functions of  $X \sim T_{10}$

Exercise 1: For  $X \sim T_{10}$ , graph the pdf of  $X$  and find the probabilities  $P(X \leq -1)$ ,  $P(X > 2)$  and  $P(-1 < X \leq 2)$ .

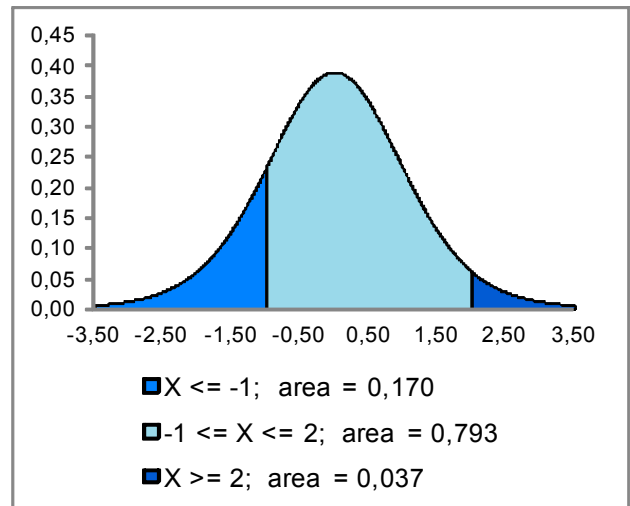

Figure 16. Pdf of  $X \sim T_{10}$  and probabilities computed with Excel

```
> pdist("t",c(-1,2),df=10)
[1] 0.1704466 0.9633060

> 0.9633060-0.1704466
[1] 0.7928594
```

Figure 17. Probabilities computed with the package *mosaic*

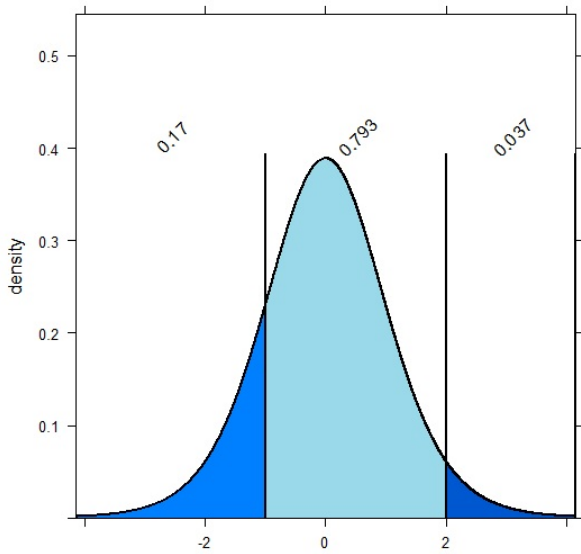

Figure 18. Pdf of  $X \sim T_{10}$  and probabilities computed with the package *mosaic*

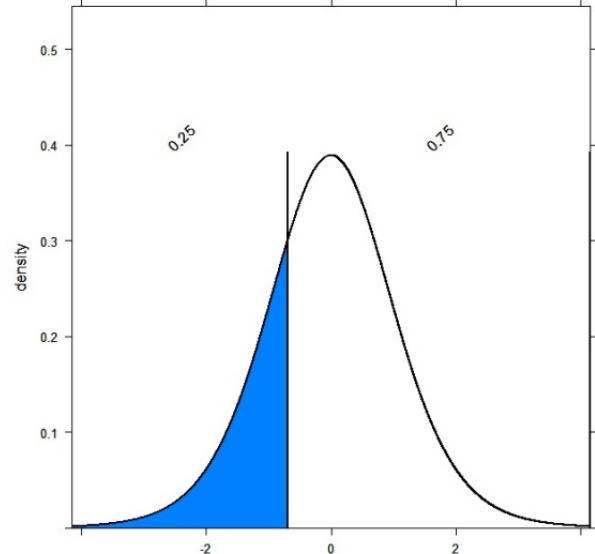

Figure 21. Pdf of  $X \sim T_{10}$  and quantile 0.25 computed with the package *mosaic*

Exercise 2: For  $X \sim T_{10}$ , graph the pdf of  $X$  and find the percentile 25, which is the value separating the bottom 25% from the top 75%.

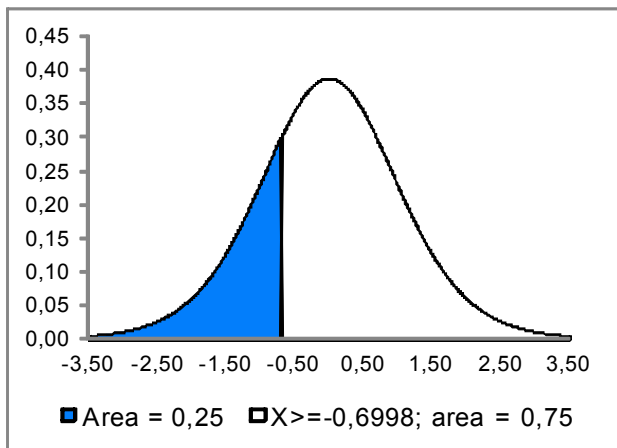

Figure 19. Pdf of  $X \sim T_{10}$  and quantile 0.25 computed with Excel

```
> qdist("t",0.25,df=10)
[1] -0.6998121
```

Figure 20. Quantile 0.25 computed with the package *mosaic*

## 7. The F-distribution

Consider  $X \sim F_{20,8}$ , an  $F$  distributed random variable with 20 and 8 degrees of freedom, whose pdf and cumulative distribution function are graphed in Fig. 22.

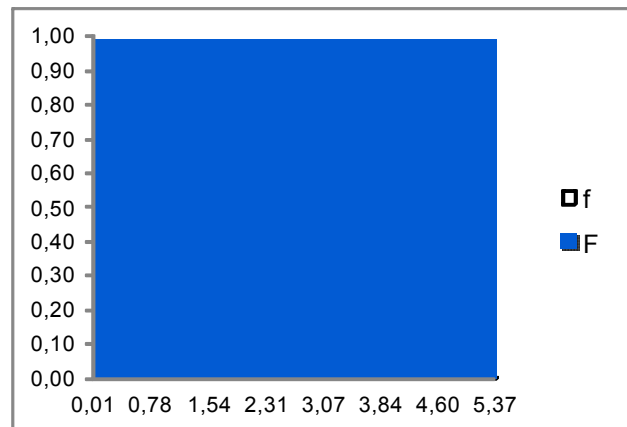

Figure 22. Probability density ( $f$ ) and cumulative distribution ( $F$ ) functions of  $X \sim F_{20,8}$

Exercise 1: Graph the pdf of  $X$  and find the probabilities  $P(X \leq 2)$ ,  $P(X > 3.41)$  and  $P(2 < X \leq 3.41)$ .

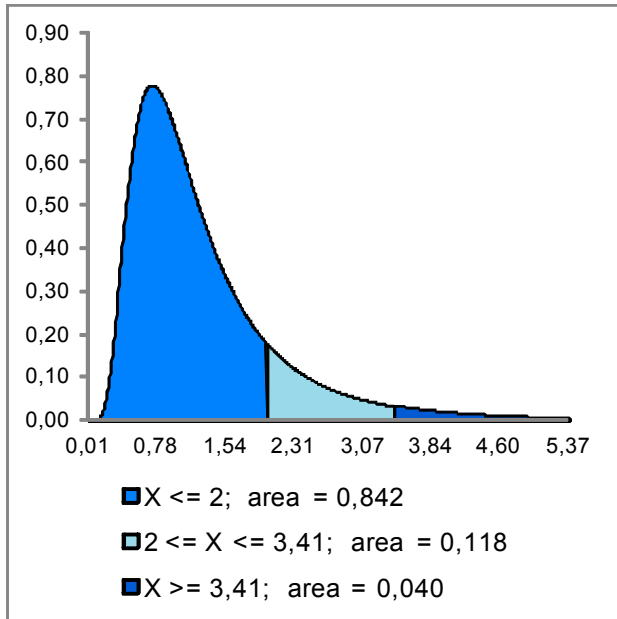

Figure 23. Pdf of  $X \sim F_{20,8}$  and probabilities computed with Excel

```
> pdist("f", c(2, 3.41), df1=20, df2=8)
[1] 0.8419226 0.9600363

> 0.9600363 - 0.8419226
[1] 0.1181137
```

Figure 24. Probabilities computed with the package *mosaic*

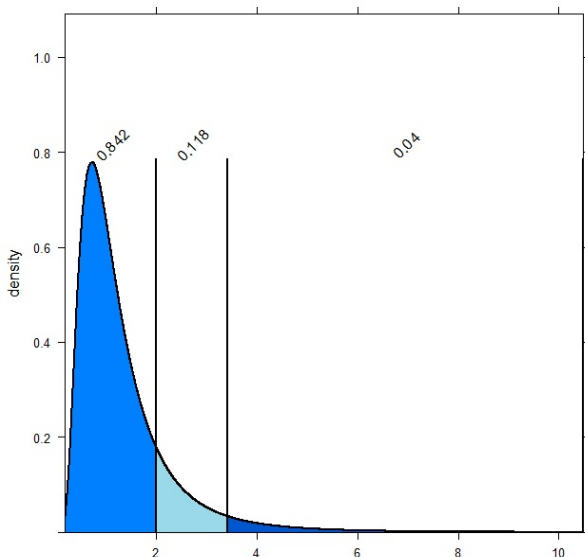

Figure 25. Pdf of  $X \sim F_{20,8}$  and probabilities computed with *mosaic*

Exercise 2: Graph the pdf of  $X$  and find the quantile 0.96, which is the value separating the bottom 96% from the top 4%.

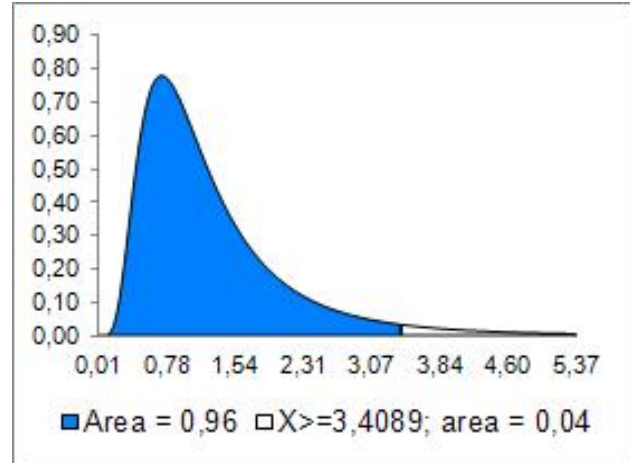

Figure 26. Pdf of  $X \sim F_{20,8}$  and quantile 0.96 computed with Excel

```
> qdist("f", 0.96, df1=20, df2=8)
[1] 3.408922
```

Figure 27. Quantile 0.96 computed with the package *mosaic*

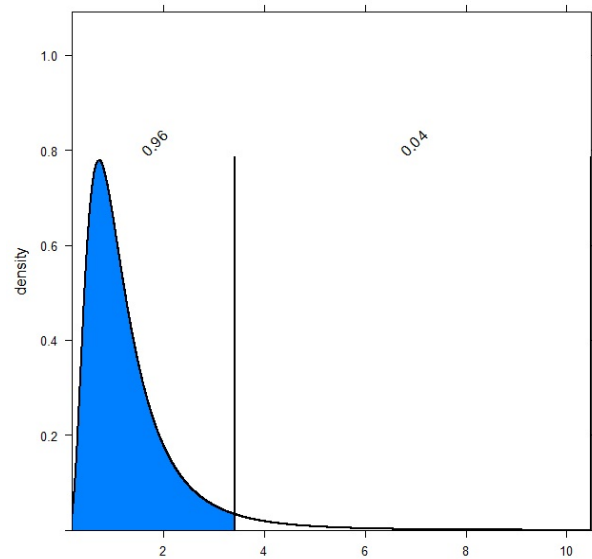

Figure 28. Pdf of  $X \sim F_{20,8}$  and quantile 0.96 computed with *mosaic*

## 8. Final remarks

Computing probabilities and quantiles can be a teaching challenge within the areas where the students have a *soft* mathematical background. The use of the probability tables, presented in any statistical book, is usually done after a quick sketch by hand of the corresponding probability density function. In this work we showed that softwares like R and

Excel can be used to graph probability density functions in a more accurate and appealing way. We hope to have encouraged the use of these softwares (or other similar ones) also in the teaching and learning of probability distributions.

## 9. References

- [1] Pestana D D, Velosa S F. Introdução à Probabilidade e à Estatística. Lisboa: Fundação Calouste Gulbenkian; 2008.
- [2] Ross S M. Introduction to Probability and Statistics for Engineers and Scientists. San Diego, Academic Press; 2000.
- [3] Triola M F. Elementary Statistics. United States of America: Addison Wesley Longman, Inc; 2001.
- [4] R Core Team. R: A language and environment for statistical computing. R Foundation for Statistical Computing, Vienna, Austria, 2015. <http://www.r-project.org/> [visited 19-Jun-2015]



## Hands-on Experiments and Creativity

*E Trnova*

*Masaryk University, Czech Republic  
trnova@ped.muni.cz*

**Abstract.** Creativity of students and teachers plays a very important role in education. According to experts a creative teacher is necessary to develop students' creativity. Based on our design-based research, hands-on experiments can be the appropriate tool for the development of creativity of students and teachers. Hands-on experiments include student activities, meaningful content, critical thinking and strong motivation. These components correspond to the basic components of creativity. Implementation of hands-on experiments into science teaching/learning involves basic processes that give rise to creativity. The study presents the design-based research outcomes of the implementation of creativity development methods in science education and also in science teacher training.

**Keywords.** Creativity, development, hands-on experiments, science education.

### 1. Introduction

Today's students are growing up in a world that is very different from the world of their parents and grandparents. In this world of technological and scientific development, human skills and especially creativity are key resources [28] which are necessary for the survival and prosperity of future generations in the 21st century [22]. Creativity is considered a relevant competency for the 21st century ([27], [29]) and needs to be included in education as a fundamental life skill [5]. To succeed in today's society with a strong emphasis on creativity, students must learn to think creatively, so they must learn to be creative ([5], [28], [25], and [29]).

According to experts it is of upmost importance that creativity is developed ([11], [23], [34], and [36]) and that everyone has the potential to be creative ([7], [9], [10], and [21]). But Robinson [27] is of the opinion that schools suppress ("kill") creativity. According to Sternberg and Williams [32], it is possible to observe creativity in young children, but it is

harder in older children and adults because their creativity potential has been suppressed by a society which supports intellectual conformity. Children's natural creativity is stifled when children start to differ from standard procedures in their activities. It begins in kindergarten when teachers correct children who draw things with unusual colours or fancy shapes.

Though intensely criticized for killing the innate creativity of children, a school seems to remain the only institution capable of promoting creativity on a large scale. Unfortunately, not all teachers are able to deal with the characteristics and behaviours of the creative child who deviates from the norm - the risk taker, the curious, impulsive child. But based on experts we can state that only creative teachers can develop student creativity ([20], [27], [28], [39], and [40]). That is why creation of methods for the development of teacher creativity, as a part of teacher education, is a necessity. Treffinger [37] suggested that creativity is related to the discovery process and considered hands on experiments to be one of the ways to develop the discovery process, and thus to develop creativity as well. In the frame of our research we discovered that an effective method of the development of science teacher creativity is the training of teachers in hands-on experiments [41], which promote creativity in both teachers and students.

### 2. Creativity in education

It is necessary to introduce a theoretical base of creativity. The common definition of the term creativity should be presented. However, it is difficult to define creativity. "The concept of creativity has traditionally proved an elusive one to pin down" ([4], p.13). Based on an analysis of published materials about creativity carried out by Rhodes [26], there were more than 40 different definitions of creativity in the second half of the 20th century. Treffinger, Young, Shelby, and Shepardson [38] state that there are approximately 100 definitions of creativity, depending on the ways in which authors view the creative function. "Some definitions are formulated in terms of a product, such as an invention or discovery; others, in terms of a process, a kind of person, or a set of conditions" ([35], p. 552). All of these things make it difficult to define creativity. Commonly,

creativity involves characteristics such as novelty, originality, usefulness, appropriateness and impact on society, as illustrated by the definition created by Hennessey & Amabile ([15], p. 347): "A product is considered creative to the extent that it is both a novel and an appropriate, useful, correct, or valuable response to an open-ended task".

For the purposes of our paper, insight into creativity in the context of education is very important. Lin [20] states that while respecting theories from the scholarly field of creativity studies, such as the behaviourist, cognitive, social-psychological, or humanistic approach, the approach to creativity in education has unique concerns, including the relationship between creativity and knowledge, curriculum, and appropriate pedagogical strategies to foster creativity in the classroom [6]. The important fact is that creativity can be developed and that everyone has the potential to be creative ([7], [9], [10], and [21]).

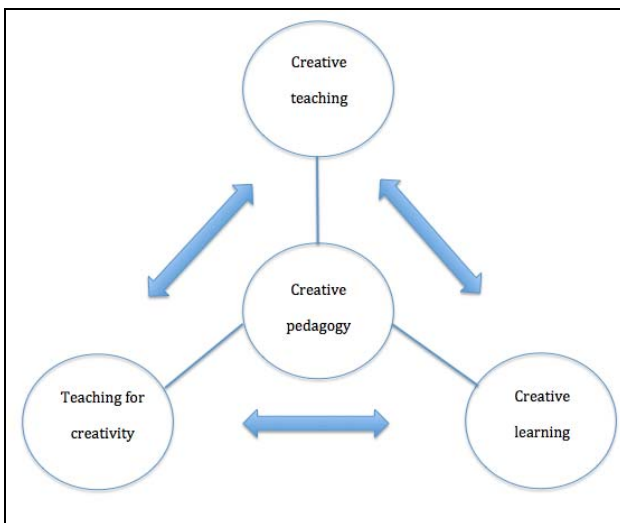

Figure 1. Creative pedagogy ([20], p. 152)

A commonly discussed issue in the expert community is the distinction between teaching creatively and teaching for creativity. According to the report from the National Advisory Committee on Creative and Cultural Education [21] (this distinction is in its characterization of creative teaching. Teaching creatively is defined as "using imaginative approaches to make learning more interesting and effective" ([21], p. 89). Teaching creatively means that teachers use their own creative skills to make ideas and content more interesting and comprehensible. Teaching for creativity is defined as forms of teaching that are aimed to develop students' own creativity. It involves

instructional strategies designed to encourage students to think and act creatively. It is desirable to encourage students to experiment, to innovate, not giving them all the answers but giving them the tools they need to find out what the answers might be or to explore new avenues. The development of creativity in students is dependent, at least in part, on the environment in which they participate [31]. Expectations and thoughts held by teachers about the characteristics of creative children may have a very powerful influence on the children with whom teachers interact [31].

But this distinction has been commented [16] on and criticised [1]. And even in the NACCCE report it is written that "teaching for creativity involves teaching creatively" ([21], p. 90) because "young people's creative abilities are most likely to be developed in an atmosphere in which the teacher's creative abilities are properly engaged" ([21], p. 90). In accordance with these statements a teacher is a very important person in "teaching" and that is why we do not put emphasis on the above mentioned distinction in our paper. Our solution is also based on the scheme (Fig. 1) concerning creative pedagogy which expresses the relationship between creative teaching, teaching for creativity and creative learning ([20], p. 152).

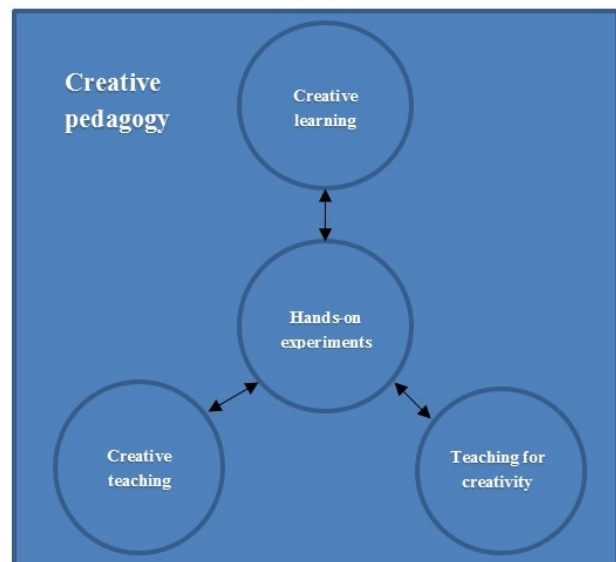

Figure 2. Hands-on experiments in creative pedagogy

Additionally, hands on experiments support all components of creative pedagogy (Fig. 2). Implementation of hands-on experiments into teaching/learning allows us to apply all three



components of creative pedagogy and develop both the creativity of teachers (creative teaching and teaching for creativity) and the creativity of students (creative learning).

Developing creativity through education is confirmed by many studies. Lin [20] presents three components of developing creativity through education: teaching, environment and the teacher. "Teaching" means the processes in providing creative and innovative educational strategies which stimulate the development of multiple intelligences [2], possibility thinking [6], and higher-level thinking [42], or how to involve the opportunity of exploring and solving problems [11]. To be "teaching" successfully it is necessary to create the second component, "environment", supporting learners' motivation/enthusiasm ([3], [13], and [14]) and creative behaviour [6]. The third component, "teacher", connects the two previous components; the teacher creates a suitable environment supporting creativity using creative and innovative educational strategies. So the teacher should be creative - he/she should have an open attitude towards creative ideas or behaviours and valuing independent thinking ([6], [7], [8], and [21]). The creative process helps to increase student learning and involvement, and it gives the teacher the opportunity to present learning material in new and innovative ways. Creativity in the classroom builds the foundation for students' adaptability and skills in problem solving. Based on our research, hands-on experiments seem to be the appropriate way for the development of teacher and student creativity because they involve all the above mentioned components. In science education there is a common consensus about the importance of hands-on experiments for students' development and fostering their interest about science. But it is not the case that every hands-on experiment supports students' development in science and in creativity as well. Hands-on experiments which are performed exactly according to the "manual" are not useful for students: they do not add anything to acquisition or the understanding of science, they do not foster interest and it is clear that they cannot develop creativity. To develop creativity Rogers [30] recommends two basic aspects:

(1) Mental security – no products, ideas, opinions or beliefs of participants were

criticized or even mocked;

(2) Mental freedom - participants had freedom for conceptualization and the expression of ideas which emerged in their minds, their ideas, opinions or beliefs were respected and taken into consideration.



**Figure 3. One loop electric motor**

It is necessary to distinguish the style and level of creativity. Kirton's Adaptation-Innovation Inventory is a measurement tool of the KAI theory ([17], [18], and [19]). The KAI inventory was developed to measure differences in cognitive styles. According to the points individuals get in KAI, it is possible to put each of them into two groups, adaptors and innovators [17]. Everyone can be located on a continuum ranging from highly adaptive to highly innovative. Highly innovative individuals prefer to do things differently, to challenge the paradigm or structure. They are sometimes seen as undisciplined, thinking tangentially, and as approaching tasks from unexpected angles. They bring radical solutions to problems. If the teacher is not aware of the different styles of creativity, student with features of an innovator can be considered naughty or unruly. Highly adaptive individuals prefer to improve things while working within the given paradigm or structure. They are characterized by precision, reliability, efficiency, discipline and conformity. They are sometimes seen as both safe and dependable in their work. Adaptors reduce problems by improvement and greater efficiency ([19], [24]). To put it shortly, innovators "do things differently" and adaptors

“do things better” ([17], [24]). Individuals possess a share of each style; however, each of us prefers one style to the other [12]. Each style has its own strengths and weaknesses. One style is not better than the other; both styles are useful. According to Šorgo et al. [33] adaptors could be better in creative teaching and inventors (innovators) in teaching for creativity.

### 3. Hands-on experiments in creative learning

An important part of science learning creativity is experiments. Simple experiments, particularly hands-on experiments, have an important role. These experiments allow the creation of new and/or alternative experiments. As an example, we present a hands-on experiment created by students:

*The students were given the task to build a functional electric motor. In the lab, students had to find simple tools, materials and other supplies (magnets, batteries, wires, nuts and bolts, soldering iron, etc.). The students were divided according to their style of creativity to work in groups (adaptors) or to work independently (innovators). When solving this project task the students created several different hands-on electric motors. The one loop electric motor is shown as an example.*

*One strong magnet attached to the bottom of the battery. The loop is placed on top of the battery. Make sure the loop touches the magnet gently (at least sometimes). Using strong magnets here is important. Using a strong magnet needs special attention, make sure to have a spare battery, apply current only during short time intervals.*

Students' creativity can be further developed by implementation of minds-on questions as follows:

- *Predict the direction in which the loop will turn.*
- *What would happen if we doubled the current in the loop?*
- *What would happen if we took opposite directions for the magnet?*
- *What would happen if we took opposite directions for the current in the loop?*

- *If the loop was not closed (at the top of the battery), would it turn?*
- *If the loop only had one “arm” would it turn?*

### 4. Hands-on experiments in creative teaching and teaching for creativity

Teachers should be well prepared for teaching science and teaching for creativity. Courses developing knowledge and skills for creative learning and teaching for creativity should be included in teacher education. An integral part of these courses is the implementation of hands-on experiments. Teachers must be prepared for creative teaching and teaching for creativity, but should develop their own creativity. As an example, we present a set of hands-on experiments created by teachers during a training course for creativity:

*The teachers were given the task to create the most hands-on experiments from different areas of physics using boxes of matches as basic objects. In the lab, teachers had to find simple tools, materials and other supplies (string, paper, glue, candle, rubber band, magnets, batteries, wires, etc.). Also, teachers were divided according to their style of creativity to work in groups (adaptors) or to work independently (innovators). The teachers created a series of hands-on experiments:*

- *Box-measuring instrument*
- *Newton's Third Law*
- *Inertia*
- *Equilibrium*
- *Stability*
- *Friction*
- *Climbing box*
- *Box on string*
- *Wave machine*
- *String telephone*
- *Singing box*
- *Resonance*
- *Electric force*
- *Magnetic field*
- *Pinhole camera*
- *Eye illusion*

These hands-on experiments served in the development of teachers' creativity and can be very effectively used in students' creative learning.



**Figure 4. Wave machine made from match boxes**

## 5. Conclusion

Creativity is as important in education as literacy and therefore it should be included in education as a fundamental life skill that will enable future generations to survive and thrive in the 21st century. The design-based research results show that the issue of creativity is among the hot topics of science educational research. Science teachers should obtain professional competence for teaching for creativity and creative teaching. The aim of these teachers' activities should be the effective creative learning of students. The teacher's attitude greatly influences the development of creativity. But the research findings suggest that teachers prefer intelligent students to creative ones because they do not know how to educate creative students. Research confirms that good school assessment of students relates more to intelligence than to creative thinking. Teachers need strategies for fostering students' creativity and the possibility for developing their own creativity. The hands-on experiment is an appropriate and important educational instrument for the development of creativity of students and teachers. Hands-on experiments are given an even more significant role in science education.

## 6. References

- [1] Alexander R, Rose J, Woodhead C. Curriculum organisation and classroom practice in primary schools: a discussion paper. London: HMSO; 1992.
- [2] Armstrong T. Multiple intelligences in the classroom. Alexandria, VA: Association for Supervision and Curriculum Development;

2000.

- [3] Collins MA, Amabile TM. Motivation and creativity. In: Sternberg RJ, editor. Handbook of creativity. Cambridge: Cambridge University Press; 1999.
- [4] Craft A. An analysis of research and literature on creativity in education. Qualifications and Curriculum Authority; 2001a.  
<http://www.ncaction.org.uk/creativity/creativity-report.pdf> [visited 4-May-2015]
- [5] Craft A. Creative development in the early years: some implications of policy for practice. Curriculum journal 1999; 10(1): 135-150.
- [6] Craft A. Creativity in schools: Tensions and dilemmas. London: Routledge; 2005.
- [7] Craft A. Little c creativity. In: Craft A, Jeffrey B, Leibling M, editors. Creativity in education. London: Continuum; 2001b.
- [8] Craft A. Possibility thinking in the early years and primary classroom. In Tan AG (Ed.), Creativity: A handbook for teacher. Singapore: World Scientific; 2007.
- [9] Esquivel B. Teacher behaviors that foster creativity. Educational Psychology Review 1995; 7(2): 185-202.
- [10] Feldman DH, Benjamin AC. Creativity and education: An American retrospective. Cambridge Journal of Education 2006; 36: 319-336.
- [11] Fryer M. Creative teaching and learning. London: Paul Chapman Publishing Ltd.; 1996.
- [12] Gregorc AF. Learning/teaching styles: Potent forces behind them. Educational leadership 1979; 36(4): 234-236.
- [13] Hennessey BA. Creativity and motivation in the classroom: A social psychological and multi-cultural perspective. In: Tan AG, editor. Creativity: A handbook for teachers. Singapore City: World Scientific; 2007.
- [14] Hennessey BA. Social, environmental, and developmental issues and creativity. Educational Psychology Review 1995; 7: 163-183.

- [15] Hennessey BA, Amabile TM. Consensual assessment. *Encyclopaedia of creativity* 1999; 1: 347-359.
- [16] Jeffrey B, Craft A. Teaching Creatively and Teaching for Creativity: distinctions and relationships. *Educational Studies* 2004; 30(1): 77-87.
- [17] Kirton MJ. *Adaptors and innovators: Styles of creativity and problem-solving*. London: Routledge; 1994.
- [18] Kirton MJ. *Manual: Kirton adaptation-innovation inventory (3<sup>rd</sup> Ed.)*. Hatfield, UK: Occupational Centre; 1999.
- [19] Kubes M. Adaptors and innovators in Slovakia: Cognitive style and social culture. *European Journal of Personality* 1998; 12(3): 187-198.
- [20] Lin YS. Fostering creativity through education - a conceptual framework of creative pedagogy. *Creative education* 2011; 2(03): 149-155.
- [21] NACCCE. *All our futures: creativity, culture and education*. London: DfEE; 1999.
- [22] Parkhurst H. Confusion, lack of consensus, and the definition of creativity as a construct. *Journal of Creative Behaviour* 1999; 33: 1-21.
- [23] Parnes SJ. Education and creativity. *The Teachers College Record* 1963; 64(4): 331-331.
- [24] Puccio G. Creative problem solving preferences: Their identification and implications. *Creativity and Innovation management* 1999; 8(3): 171-178.
- [25] Resnick M. Sowing the Seeds for a More Creative Society. *International Society for Technology in Education* 2007; 35(4): 18-22.
- [26] Rhodes M. *An analysis of creativity*. Phi: Delta Kappan; 1961.
- [27] Robinson K. Do schools kill creativity? In: Presentation at TED2006 Conference, Monterey, CA; 2006.
- [28] Robinson K. *Out of our minds: Learning to be creative*. Capstone; 2011.
- [29] Rocard M, Cesrmlay P, Jorde D, Lenzen D, Walberg-Herniksson H, Hemmo V. *Science education NOW: A Renewed Pedagogy for the Future of Europe*. Brussels: Office for Official Publications of the European Communities; 2007. [http://ec.europa.eu/research/science\\_society/document\\_library/pdf\\_06/report-rocard-on-science-education\\_en.pdf](http://ec.europa.eu/research/science_society/document_library/pdf_06/report-rocard-on-science-education_en.pdf). [visited 15-Feb-2015]
- [30] Rogers K. Is creativity quantitatively measurable? A paradigm for creativity research. *Investigating creativity in youth: Research and methods* 1999; 217-237.
- [31] Runco MA. *Creativity: Theories and themes: Research, development, and practice*. Elsevier; 2014.
- [32] Sternberg RJ, Williams WM. *How to develop student creativity*. Alexandria, Virginia; ASCD; 1996.
- [33] Šorgo A, Lamanauskas V, Šašić SŠ, Kubiato M, Prokop P, Fančovičova J, Bilek M, Tomažič I, Erdogan M. A Cross-National Study of Prospective Elementary and Science Teachers' Creativity Styles. *Journal of Baltic Science Education* 2012; 11(3): 285-291.
- [34] Torrance EP. *Education and the creative potential*. Minneapolis, MN: The University of Minnesota Press; 1963.
- [35] Torrance EP. The creative person. *The Encyclopedia of Education*. p. 552-557; 1971.
- [36] Torrance EP, Myers RE. *Creative learning and teaching*. New York: Dodd, Mead & Company; 1970.
- [37] Treffinger DJ. *Encouraging creative learning for the gifted and talented*. Ventura, CA: Ventura County Schools/LTI; 1980.
- [38] Treffinger D, Young G, Shelby E, ôc Shepardson C. *Assessing creativity: A guide for educators*. Storrs, CT: The National Research Center on the Gifted and Talented; 2002.
- [39] Trna J. How to motivate science teachers to use science experiments. *Journal of Systemics, Cybernetics and Informatics*

2012; 10 (5), 33-35.

[40] Trna J. Motivation and Hands-on Experiments. In: Selected Papers on Hands-on Science. Braga, Portugal: Associacio Hands-on Science Network; 2008. p. 221-230.

[41] Trna J. New Roles of Simple Experiments in Science Education. Brno: Paido; 2014.

[42] Yeh YC. Creativity teaching-past, present, and future. Taipei: Psychological publishing; 2006.



## The Perception of the Population that Captures Mussels and Barnacles at Easter on Measures of Ecosystem Conservation

M Jeremias<sup>1</sup>, S Seixas<sup>1,2</sup>

<sup>1</sup>Universidade Aberta, Lisboa, Portugal

<sup>2</sup> Universidade de Coimbra, Portugal  
sonia.seixas@uab.pt

**Abstract.** The perception of the population that captures mussels (*Mytilus galloprovincialis*) and barnacles (*Pollicipes pollicipes*) on Holy Friday on the campaign launched by the Cascais city council (“At Easter the one who pays is the mussel”) to prevent the depletion of the stocks and their opinion on the need of preservation of these two species and biodiversity in intertidal area.

To evaluate it we went to the area where the campaign was launched and made a questionnaire to each family, in a total of 62 surveys.

This activity is mainly carried out by men between the ages of 30 and 60 years old. 62% of the pickers came from different areas of the council, 30% come from neighbouring councils and the other 8 % from distant places.

The results confirm that the capture is mainly done at Easter (82%). 41% of the people inquired collect mussels, 16% collect barnacles and 43% collect both species.

The majority of the pickers knows the maximum weight allowed to capture mussels but doesn't know it about barnacles and less than half of the people answer correctly about the minimum length of the mussel shell. 94% state that the capture is done to private consumption. The perception of the people about the need of conservation of both species and biodiversity in intertidal is above 70%.

As far as the campaign is concerned, people, in general, agree with it but their answers are not consensual: some said it is very good (40%) while others said that it is very bad (47%). About the reinforced surveillance done during this day by the Maritime and the City Council Police almost everybody said that it may end up with this tradition.

**Keywords.** *Mytilus galloprovincialis*, *Pollicipes*

*pollicipes*, mussel, barnacle, Holy Friday capture, conservation, biodiversity.

### 1. Introduction

#### 1.1. Species

This work is about the harvest, on Holy Friday, of two species:

- *Mytilus galloprovincialis* Lamarck, 1819, called the Mediterranean mussel,
- *Pollicipes pollicipes* (Gmelin, 1789) called pedunculated barnacle or stalked barnacle

The Mediterranean mussel *Mytilus galloprovincialis* is a bivalve which lives in Portugal in low mid-shore zone of exposed shores [1]. This specie is commonly captured in intertidal zone and is a popular dish to be cooked to family and / or friends.

In Cascais, a study on mussels found a negative correlation between the accessibility to sites and the abundance of mussels [2] and another study on the grading of human disturbance showed that the effects depend on the distance from the access point [3].

The stalked barnacle *Pollicipes pollicipes* is a crustacean that lives exposed on rocky shores. This specie is a very important economical resource on intertidal rocky shores of continental Portugal. The pressure over this resource is enormous and is aggravated with the actual financial crisis. A study done in Portugal by Sousa *et al.* (2013) [4] concluded that the higher proportion of adult barnacles was found in low shore while juveniles were relatively more abundant at mid shore.

The present maximum weight allowed to capture is (Portaria n. ° 14/2014) [5]:

- Mussels – 3 kg per person
- Barnacles – 0.5 kg per person

In the past, when the campaign was launched, it was: mussels - 2 kg and barnacles - 0,5 kg.

The rise in the quantity of capture allowed does not take into consideration the pressure that non-professional people do in intertidal area.



The minimum length of mussel shell allowed to capture is 5 cm.

There is no minimum length for barnacles. In fact, except for the marine protection areas of the Southwest coast and the Berlenga islands there is no specific legislation on barnacles. This subject has been discussed in the media in the last months.

## 1.2. Study Area

This work was developed on the Atlantic coast in Cascais, Portugal.

This is a carsic area, with very eroded platforms where the beaches are formed by dunes, sand and sedimentary rocks witch allow a special environment with a very rich biodiversity including the one of the intertidal area.

The chosen local is Arriba Beach, a beach without supervision, with two areas of sand separated by a cliff. The rocky part that is exposed at low tide is populated with mussels and barnacles (Fig. 1 and 2).

The hydrodynamism is high and wave direction is mainly along N-W direction.

The surveys are done at Holy Friday 03-April-2015, between 07:30 am till 12:30 am.

The sun rise occurred at 6:46 am [6].

The low tide occurs at 08:55am height 1 m and the high tide have been at 15:15 am height 3.4 m. [6]

## 1.3. Campaign

According Christian Calendar, Easter is celebrated on the first Sunday after de first full moon of the spring's Equinox. Every Holy Friday the lunar cycle synchronism with high and low tide originates a very low tide, ideal for the capture of mussels and barnacles [7]. Happening on the day the Christians do not eat meat soon this capture became a family tradition in Cascais. During the morning many family capture lots of mussels and barnacles in a few hours. The results are a deep derangement in the intertidal ecosystem provoking a serious depletion of those two species. Since 2011 the environmental department of the Cascais city council launched a campaign named "Na Páscoa quem paga é o

Mexilhão" (At Easter the one who pays is the Mussel) [8], trying to touch everyone to the preservation of those resources, which are fundamental in the biodiversity of intertidal area.



**Figure 1. Map of Study Area signaling the local of surveys with arrow yellow. Source: Google maps (38.719367, -9.480802)**

So on the Holy Friday, from 7:00 am and during all morning, some people responsible for this campaign and some police officers go to the capture places to sensitize the pickers and subject their capture to surveillance and control. They explain the situation and given people a flyer (Fig. 3). Technical teams were also equipped with scales to weigh bags collected when in doubt.

This year, 2015, the campaign was done only in the capture places and trough the local media.

With this work, we aim at understanding how

people react to this campaign and what they think about it. We want also to check if the pickers know the legislation that regulates this practice.



Figure 2. Pictures in the Holy Friday: Mussel's and barnacle's capture. Arrow yellow is the first author doing the surveys

## 2. Methodology

### 2.1. Surveys

The survey was designed and pre-tested, in a small group.

The survey targeting people capture mussels and barnacles in intertidal during the low tide (Fig. 2).

The survey had five parts:

- Personal data
- Knowledge of capture habits

C. Knowledge of the activity (legal aspects)

D. Perception about the preservation of resources

E. Evaluation of the campaign "At Easter who pays is the mussel"



Figure 3. Campaign flyer "At Easter who pays is the mussel"

The personal data included gender, age and address.

The knowledge of capture included four different aspects: habits of capture, i.e. which specie or species they capture, if capture was done by hand or with the help of an instrument, the frequency of captures and the final destination of captures.

The knowledge of the activity (legal aspects) included the maximum weight allowed to capture:

- Mussels – 3 kg per person
- Barnacles – 0.5kg per person,

and the minimum length of mussel shell allowed which is 5 cm.

In past when campaign was established the level of mussels were 2 kg and barnacles 0,5 kg.

To know their perception about the preservation of resources we asked them to scale between 1 and 5, according to the Likert scale (psychometric scale) the need of preservation of mussels, barnacles and intertidal area.

To evaluate the campaign “At Easter the one who pays is the mussel” we also used the Likert scale and asked them if the inspection methods were adequate, if they agreed with the campaign and if the information provided by the people responsible for the campaign was good.

The results of the survey were introduced in the LimeSurvey programme to facilitate their understanding.

## 2.2. Statistical treatment

SPSS software (IBM SPSS Statistics V21) was used for the statistics methodology, with a 0.05 value of significance.

## 3. Results

We did 62 surveys on the Holy Friday in the study area during the low tide in the morning. The low tide was at 08:55 a.m.

### 3.1. Personal Data

The treatment of the surveys gives us a universe of 78% males and 22% females.

The age of pickers can be seen in Fig.4.

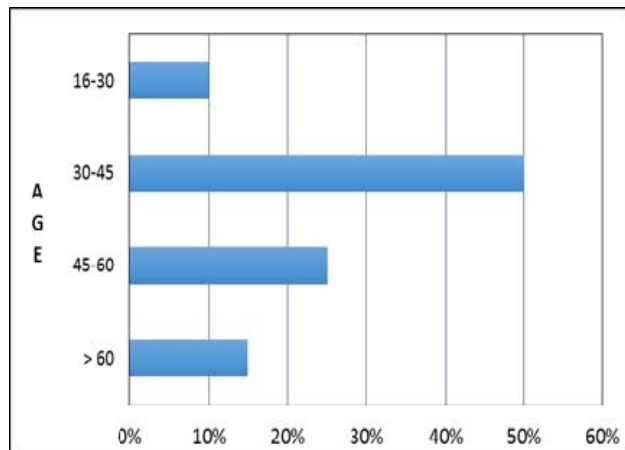

**Figure 4. Age of people inquired**

62% of the pickers come from different areas of the council (Cascais), 30% come from neighbouring councils (Oeiras and Sintra) and the other 8 % from distant places.

### 3.2. Knowledge capture habits

41% of the people inquired collect mussels, 16% collect barnacles and 43% collect both species (Fig. 5).

The answers demonstrated that 57% only use the hands and 43% use some instrument

to collect the bivalves. Most of the instruments used are knives (56%), spatulas (28%) and other different instruments (16%).

Most of the people inquired say that they only pick up mussels and barnacles on the Holy Friday (Fig. 6).

The destination of the capture is said to be mainly eaten at home with family and friends (96.6%), while only 3.45% reveals that sell it.

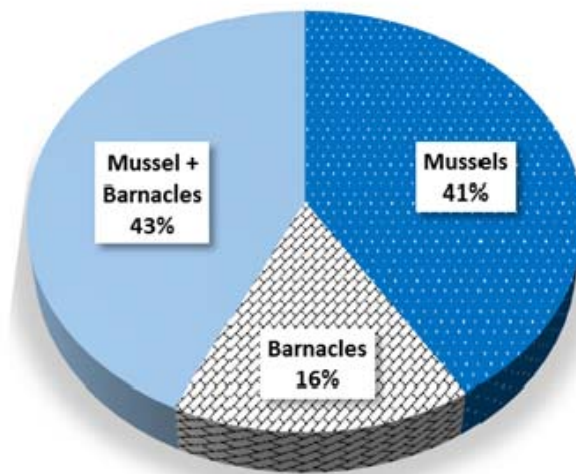

**Figure 5. Captures ‘type**

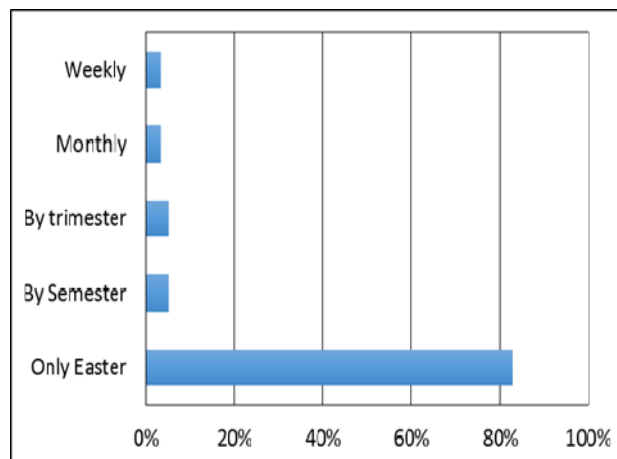

**Figure 6. Captures frequency**

### 3.3. Knowledge of the activity (legal aspects)

To understand the pickers’ knowledge of legal aspects of the activity several questions were asked.

The percentage of people who know the maximum weight allowed to capture was:

- Mussels – 67%



- Barnacles – 48%

As far as the existence of a minimum length of mussel shell is concerned, only 47% know that there is one and of these only 27% know the correct length.

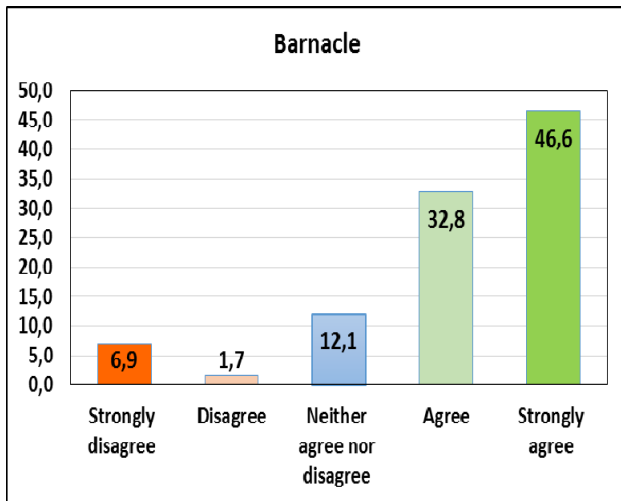
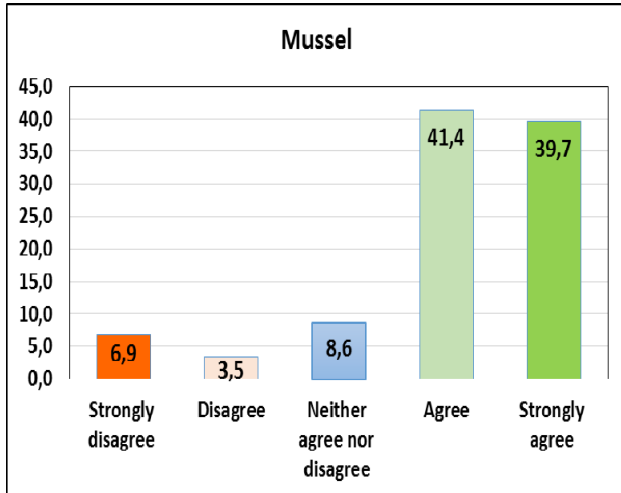

Figure 7. Preservation of species' population

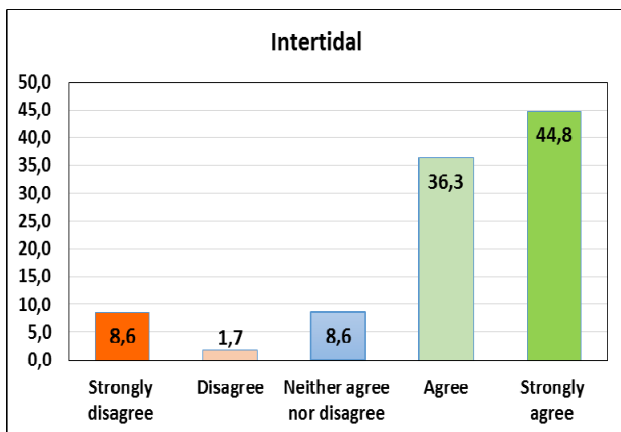

Figure 8. Preservation of intertidal area

### 3.4. Perception about preservation of the resources

The results of inquiry about the need of preservation of mussels and barnacles can be seen in Fig. 7.

Results about the need of preservation of intertidal area can be seen in Fig. 8.

### 3.5. Evaluation of campaign "At Easter the one who pays is the mussel"

It was inquired if they agree with this campaign "At Easter the one who pays is the mussel". The results can be seen in Fig. 9.

Was also asked them how would classify the information provided by the people responsible for the campaign in the captures places. The answer can be seen in Fig 10.

When we asked this question most of the people answered that the information provided by the technicians was very bad but we realized that these people were afraid of legal aspects, namely being fined, and avoided those technicians.

When we asked if they agreed with the surveillance done during this day by the Maritime and the City Council Police the answers were not consensual (Fig.11).

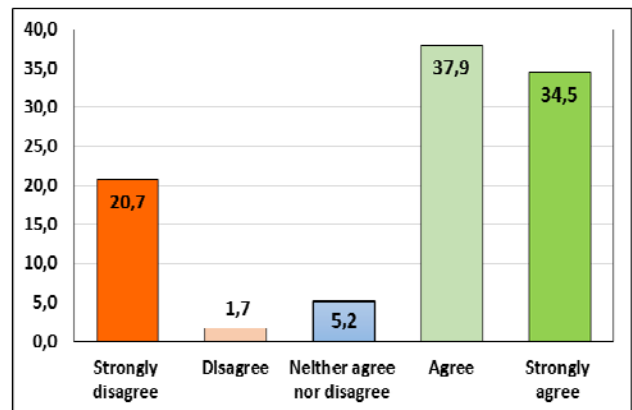

Figure 9. Agreement with campaign

Most of the people inquired strongly disagree with the actions taken by the Maritime police and the agents of campaign in the capture places.

When they were asked to give their personal opinion on the subject, most of them said that they agree with police actions but not on the Holy Friday because it is a tradition and must

be preserved. A lot of them even said that they agree with police actions and they must be increased on the rest of the time to preserve the animals in the area.

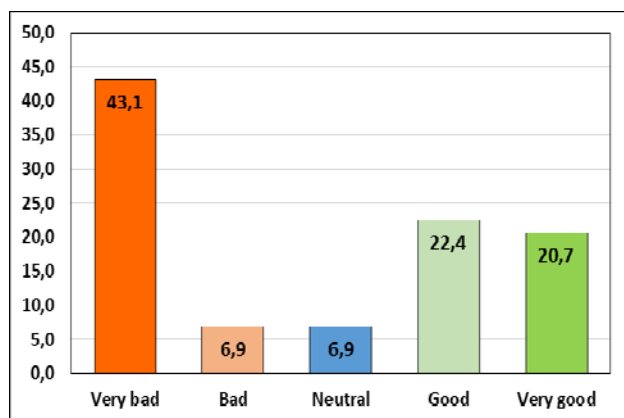

Figure 10. Opinion about personal information

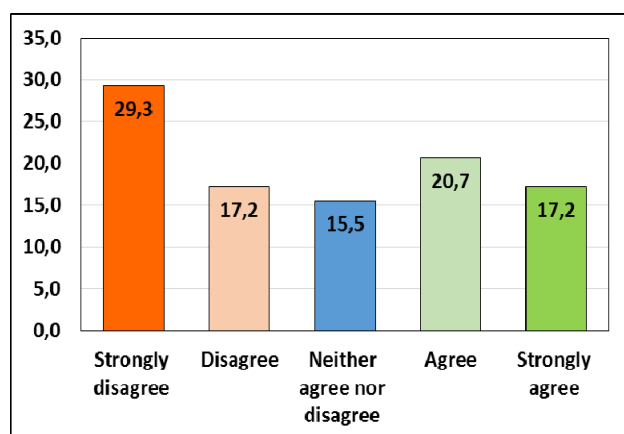

Figure 11. Opinion about control campaign

#### 4. Discussion

According to another study done in the same council, it was verified that the long-term effects of the awareness campaign seem to have a positive trend on the average length of individuals (Ferreira *et al.*, 2013) [7]. This study did not evaluate this aspect but the authors realized that people capture primarily in the areas where mussels are bigger.

We also observed that some people chose areas with bigger mussels but ended up by removing all the mussels in the area, including the smaller ones, which then throw away. The same was observed by Rius and Cabral (2004) [2], in a study in an adjacent area.

We believe that to increase the general public environmental awareness in order to change their behaviour towards this specific tradition on Holy Friday, more campaigns

should be launched and the way the information is provided should be more diversified. One way of doing this could be through the students of the area by doing some activities with them.

The perception of the population that captures mussels (*Mytilus galloprovincialis*) and barnacles (*Pollicipes pollicipes*) on Holy Friday about the damage of this activity is ambiguous. On the one hand, they agree that both species and the intertidal area must be preserved but on the other hand, they think that this tradition must continue and the reinforced surveillance on this day is wrong.

A study done by Lorena *et al.* (2014) [9], in NW Atlantic coast supports the notion that intertidal mussels are important ecosystem engineers that sustain a rich diversity of invertebrates. Mussels provide food, space, and shelter for their associated community and so their loss due to anthropogenic impacts is problematic and may provide insight into cascading effects on associated species (Smith *et al.*, 2008)[10].

Borthagaray and Carranza (2007) [11], have already stated that the richness of all macrofaunal groups was positively correlated with mussel abundance. O'Connor and Crowe (2007) [12], referred that differences in mussel size structure may affect the diversity of assemblages associated with mussel beds. This may happen because their capture occurs mainly in areas with large mussels. So the preservation of mussel beds is very important.

#### 5. Conclusion

We believe that to increase the general public environmental awareness in order to change their behaviour towards this specific tradition on Holy Friday, more campaigns should be launched and the way the information is provided should be more diversified.

It is common knowledge that to modify attitudes a change in mind is required and that it is not easy especially in cases like this one. The ancient tradition somehow justifies the maintenance of the old habit and it becomes more difficult for people in general to assume the necessity of setting a limit to the capture as the legal regulation demands. So we believe that to increase the desirable change, the

involvement of young people such as students as a new target in this matter is required and it may be possible by doing some activities with them on this issue. The maintenance of the campaign and the involvement of students may settle the change on general public.

## 6. Acknowledgements

We would like to express our gratitude to Dr<sup>a</sup> Ana Margarida Ferreira (Cascais Ambiente) for all the collaboration on the Holy Friday during our field trip, and Dr<sup>a</sup> Isabel Cristina Abreu for her linguistic suggestions.

## 7. References

- [1] Boaventura D, Ré P, Cancela da Fonseca L, Hawkins S. Intertidal rocky shore communities of the continental Portuguese coast: analysis of distribution patterns. *Marine Ecology*; 2002: 23 (1), 69-90.
- [2] Rius M, Cabral, H. Human harvesting of *Mytilus galloprovincialis* Lamarck, 1819, on the central coast of Portugal. *Scientia Marina*; 2004: 68(4), 545-551. doi: 10.3989/scimar.2004.68n4545.
- [3] Rius M, Kaehler S, McQuaid C. The relationship between human exploitation pressure and condition of mussel population along the south coast of South Africa. *South African Journal of Science*; 2006: 102, 130-136.
- [4] Sousa A, Jacinto D, Penteadó N, Martins P, Fernandes J, Silva T, Castro JJ, Cruz T. Patterns of distribution and abundance of the stalked barnacle (*Pollicipes pollicipes*) in the central and southwest coast of continental Portugal, *Journal of Sea Research*; 2013: 83, 187-194, doi:10.1016/j.seares.2013.04.005
- [5] Portaria n.º 14/2014
- [6] [www.tabuademark.com/pt/lisboa/cascais](http://www.tabuademark.com/pt/lisboa/cascais) [visited on 21-06.2015]
- [7] Ferreira A, Seixas S, Rijo A, Faria S, Fialho, V. Impact of harvest by humans on mussel populations around Easter. *Journal of Integrated Coastal Zone Management* 2013: 13(2), 145-155. Doi: 10.5894/rgci383
- [8] [www.cm-cascais.pt/projeto/campanha-na-pascoa-quem-paga-e-o-mexilhao](http://www.cm-cascais.pt/projeto/campanha-na-pascoa-quem-paga-e-o-mexilhao) [visited on 20-06-2015]
- [9] Lorena P, Arribas, Donnarumma L, Palomo M, Scrosati R. Intertidal mussels as ecosystem engineers: their associated invertebrate biodiversity under contrasting wave exposures. *Mar Biodiv*, 2014: 203–211. DOI 10.1007/s12526-014-0201-z
- [10] Smith JR, Fong P, Ambrose RF. The impacts of human visitation on mussel bed communities along the California Coast: Are regulatory marine reserves effective in protecting these communities? *Environmental Management*; 2008: 41, 599-612. doi: 10.1007/s00267-007-9066-2.
- [11] Borthagaray AI, Carranza A. Mussels as ecosystem engineers: their contribution to species richness in a rocky littoral community. *Acta Oecol*, 2007: 31, 243–250. doi:10.1016/j.actao.2006.10.008
- [12] O'Connor N, Crowe T. Biodiversity among mussels: separating the influence of sizes of mussels from the ages of patches. *Journal of the Marine Biological Association of the United Kingdom*; 2007: 87, 551-557. doi:10.1017/S0025315407050503
- 
-



## Studying Recombinant Protein Production and Regulation of Gene Expression in Genetic Transformed Bacteria using Fluorescent Reporter Protein mCherry: Molecular Tools and Procedures

B Peixoto, F Sousa, S Pereira  
Universidade do Porto, Portugal

bruno.peixoto@fc.up.pt,  
up200805829@fc.up.pt, mspereir@fc.up.pt

**Abstract.** Genetic transformation is a process by which a gene from one organism is transferred to another which acquires new genetic characteristics becoming capable of producing a new protein encoded by the transformed gene. Bacteria respond to changes in environmental and nutritional conditions efficiently by regulating gene expression. The Lac operon is a classic paradigm for gene regulation in *Escherichia coli*. We are developing easy-to-use molecular tools and procedures, based upon the quick genetic transformation of *E. coli* cells with a recombinant plasmid encoding the red fluorescent protein mCherry under the control of the Lac promoter. The influence of different concentrations of lactose and glucose in the culture medium on mCherry expression can be readily visualized.

**Keywords.** Bacterial Transformation, Fluorescent Proteins, Inducible Promoters, Recombinant Proteins, Regulation of Gene Expression.

### 1. Introduction

Biotechnology has an ever increasing societal impact in our daily lives, requiring citizens to be able to understand its main concepts, its potential and draw-backs, in order to make informed decisions regarding its applications.

Concerns on promoting both a proper understanding of biotechnology notions and procedures has been fostered by the inclusion of modern molecular biology and biotechnology contents in the Portuguese curricula, with an emphasis on the mobilization of such knowledge to concrete daily situations. Teaching programs in biotechnology rely on the

development of innovative teaching strategies such as hands-on laboratory classes that require easy-to-use tools and procedures.

Genetic transformation is commonly used in biotechnology and is a process by which a gene from one organism is transferred to another, that becomes capable of producing a new protein, encoded by said gene. This technical advance revolutionized biology, and allowed for biotechnological applications, such as the production of human insulin in bacteria. However, genes are not the sole determinants of acquired genetic characteristics. The influence of environmental factors in gene expression affects the resulting phenotype of an organism. Bacteria, in particular, respond to changes in environmental and nutritional conditions, by efficiently regulating gene expression. The *Lac* operon is a classic paradigm for the study of gene regulation in *E. coli*, and has already been used in a number of different teaching approaches.

Gene expression regulation is a common regulatory mechanism employed by all cell types, for regulating metabolism, and maximizing efficient use of limited nutritional resources. It is not uncommon for cells cultured in nutrient-poor media to downregulate, or all-together stop the expression of genes that are not required for nutrient metabolism, thus decreasing the rate of RNA and protein synthesis, both being energy-expensive processes. In bacterial cells, the most common regulatory mechanism occurs over messenger RNA transcription (mRNA), and such genes are said to be “transcriptionally regulated” [1].

Bacterial genes are commonly switched off by repressor/inhibitor proteins that bind to an operator DNA sequence, adjacent to the promoter sequence of an operon, effectively blocking access of the RNA polymerase to the DNA sequence, thus resulting in operon gene expression repression [2].

Repressor proteins are generally sensitive to nutrient levels, resulting in a modulatory effect that allows the bacterium to adjust and fine-tune their enzyme levels and structural components, thus optimizing metabolic pathways. Bacteria, such as *Escherichia coli*, have roughly 50% of genes clustered in operons, and each operon encodes enzymes that are involved in a particular metabolic pathway, or interacting proteins that form

functional complexes [3]. These operons are composed by multiple individual structural genes, all under the control of the same promoter and regulatory sequences. These promoter and regulatory sequences regulate the expression of all the genes in an operon, which are generally transcribed as a single mRNA molecule [4].

The most commonly known operon of *E. coli* is the lac operon, a DNA segment that includes a promoter, an operator, and the three structural genes lacZ, lacY and lacA, that code for lactose-metabolizing enzymes. The promoter is the DNA sequence to which the RNA polymerase binds, and the operator, which is located between the promoter and lacZ gene, is the repressor binding site. This repressor protein is encoded by the regulatory gene LacI, which is located upstream of the promoter [1]. The Lac operon is negatively regulated by this repressor protein, but is otherwise inducible by the presence of allolactose, which inactivates the repressor by directly binding to it. Thus lactose, the precursor of allolactose, is an inducer molecule that activates the expression of the Lac operon [2].

A second level of gene regulation is also in place – when in the presence of glucose, which is used preferentially by the bacterium, the catabolism of other sugars is repressed, even if lactose is present. This type of gene downregulation is termed “catabolite repression” [3].

We have developed a hands-on approach for studying the regulation of the Lac operon in *E. coli*, visually assayed by the expression of a reporter protein. The DH5- $\alpha$  *E. coli* strain was transformed with two plasmids – the pBluescript SK II vector and a recombinant plasmid (pSK-mCherry), which contains the gene coding for the reporter protein mCherry, a red fluorescent protein [5]. The pBluescript SK II phagemid (Agilent Technologies) possesses the *Lac* promoter, and an N-terminal fragment of  $\beta$ -galactosidase (lacZ) gene of *E. coli*. In the recombinant plasmid pSK-mCherry, the red fluorescent protein was cloned in the the pBluescript SK II vector, in frame with  $\beta$ -galactosidase, effectively creating a functional fusion protein under the control of the *Lac* promoter.

The LacZ fragment present in the vector, is

capable of complementation with a defective form of  $\beta$ -galactosidase enzyme, encoded by the host chromosome (mutation lacZ $\Delta$ M15 in specific *E. coli* strains). Transformed bacteria synthesize both fragments of the enzyme, presenting  $\beta$ -galactosidase functional activity, which can together hydrolyse X-Gal (5-bromo-4-chloro-3-indolyl-beta-D-galacto-pyranoside) and form blue colonies when grown on media supplemented with X-Gal.

Observing lacZ expression typically requires indirect methods, making use of chromogenic substrates like X-Gal and gratuitous inducers, such as isopropyl-beta-D-thiogalactopyranoside (IPTG). IPTG inactivates the lac repressor and is currently used to induce expression of cloned genes under the control of the *Lac* promoter because it cannot be metabolized, and therefore its concentration does not change as the cells grow. However, this is an expensive reagent and the method here developed uses the natural inducer lactose to control expression of the reporter proteins.

Expression of both reporter proteins was assayed in the presence of a glucose-lactose mix, which allows for the visualization of catabolite repression and gene induction, after bacterial transformation. The main objective is to create a stand-alone laboratory activity that can easily be integrated in the teaching of biology to students of various levels, particularly 12<sup>th</sup> grade and higher education students.

## 2. Materials & Methods

### 2.1 *E. coli* Genetic Background – DH5- $\alpha$

For the incorporation and propagation of the recombinant DNA a single strain of *E. coli* was used – the DH5- $\alpha$  strain. This strain was selected mostly due to its high transformation efficiency (even for large plasmids), the high yield of plasmid DNA produced and the low level of recombination events. The DH5- $\alpha$  strain was also the most easily transformed bacterial strain of several tested strains (data not shown).

For detecting  $\beta$ -galactosidase activity, the plasmids used must contain the lacZ $\alpha$  gene. Such is the case with the pBluescript vector. Some bacterial strains contain the mutant lacZ gene, with a partially deleted sequence (lacZ $\Delta$ M15). The strain employed in this work

contains such a mutation, resulting in the production of an inactive, truncated  $\beta$ -galactosidase enzyme. This enzyme bears an inactive carboxy-terminus, which can be readily repaired upon the expression of the rest of the lacZ gene – this mechanism is called “ $\alpha$ -complementation”, and is very commonly used in molecular biology labs, for easily screening successful ligation of a DNA insert to a vector.

For the detection of  $\beta$ -galactosidase enzymatic activity, a specific substrate is required – X-Gal (5-bromo-4-chloro-3-indolyl-beta-D-galacto-pyranoside) is an inert chromogenic substrate for this enzyme, which hydrolyzes X-Gal, resulting in the appearance of an intensely blue precipitate which colours the entire bacterial colony [6].

Base Medium	[Glucose] (w/v)	[Lactose] (w/v)
LB-Agar	0.05%	0.2%
		0.5%
		1%
	0.01%	0.2%
		0.5%
		1%

**Table 1. Different Glucose-Lactose cocktail mixes were tested in order to optimize the macroscopic observation of the catabolite repression phenomenon and Lac Promoter Induction in a short amount of time (24-48h). The formulation with the most promising results was employed for further optimization of the Quick Transformation Protocol, and the X-Gal complementation assays**

## 2.2 Vector Plasmids

pBluescript II SK is a plasmid possessing the  $\beta$ -lactamase gene, conferring ampicillin resistance, and a partial lacZ gene, encoding for the  $\alpha$ -peptide of the  $\beta$ -galactosidase enzyme. This type of vectors are easily replicated in the DH5- $\alpha$  strain, which contains the chromosomal lacZ $\Delta$ M15 mutation [7, 8]. When added to the medium, X-Gal will be hydrolyzed by transformed bacteria to a blue-coloured compound.

mCherry is a monomeric red fluorescent protein, capable of extremely rapid maturation.

This allows for very fast visualization of the protein, after transcription is activated. Another added advantage, is that due to the spectral properties of this fluorescent protein, it bears a pink-reddish hue in the visible spectrum of light, allowing for its macroscopic observation, without the need for an external UV-light source [5, 9].

The pSK-mCherry recombinant plasmid has been previously built at our Biology Department, by inserting the mCherry gene into the MCS of the pBluescript II SK plasmid, in fusion with the the lacZ $\alpha$  gene and under the control of the lac promoter sequence.

## 2.3. Media Formulation Testing

Different media formulations were tested for this practical activity. The basis for all tested media is the widely used Luria-Bertani (LB) medium, which was further supplemented with different concentrations of glucose and lactose (Table 1), in order to create an observable dynamics between the phenomenon of catabolite repression and lac promoter activation. Ampicillin sodium salt was always present at a concentration of 50  $\mu$ g/mL, to maintain selective pressure over the transformed bacteria harbouring plasmids. All media were prepared and sterilized in a microwave, which is known to be as efficient as a normal autoclave, and is much more readily available in school laboratories [10]. All medium and bacterial manipulations were done according to basic sterile techniques, in the presence of a lit flame, which is used for both flaming the utilized tools, and to create an updraft that pushes airborne contaminants away from bacterial cultures and culture media.

## 2.4. Bacterial “Quick Transformation” Protocol

For easier application in a school setting, a “quick transformation” protocol was established for transfecting *E. coli* with the pSK-mCherry plasmid. A bacterial streak plate was established in standard Luria-Bertani-Agar (LB-A) plates, overnight. A loop of this fully grown cell culture was resuspended in 95  $\mu$ L of 50 mM CaCl<sub>2</sub>. We added 5  $\mu$ L of plasmid to this cell mixture and incubated it on ice for 15 minutes.

The cells were then subjected to a heat-shock, by being incubated at 42 °C for 90

seconds, and then immediately transferred back to ice for 2 minutes. Standard LB medium was added to each tube (100  $\mu$ L), and the cells were recovered at room-temperature (RT) for 10 minutes, without agitation. The entire volume of cells was then plated in LB-Agar supplemented with 0.01% (w/v) glucose, 1% (w/v) lactose, and 50  $\mu$ g/mL ampicillin for transformant selection, and incubated overnight at 37  $^{\circ}$ C.

Alternatively, LB-Agar-glucose-lactose-ampicillin plates were further supplemented with the X-Gal reagent, by plating 30  $\mu$ L of a 25 mg/mL stock solution per plate. Transformed cells were also plated in these X-Gal<sup>+</sup> plates, and incubated ON at 37  $^{\circ}$ C, for the detection of  $\beta$ -galactosidase enzyme activity.

### 3. Results

We began this work by optimizing the LB media for this activity. We were particularly interested in demonstrating in a clear, fast and reproducible way the phenomena of catabolite repression and lac promoter induction. Towards this end, we tested several glucose/lactose cocktails in the culture medium, which resulted in the expected dynamics – by increasing glucose concentration, the expression of the mCherry reporter became slower and less noticeable, as is observable by the appearance of white colonies. This repression was intense, and for the highest concentration tested, mCherry expression was efficiently repressed even when in the presence of high lactose concentrations (1% w/v). For the lowest glucose concentration, however, we could observe a clear effect for lactose concentration, where mCherry expression became more apparent, with higher lactose levels (Fig. 1).

These results led us to adopt the lowest glucose concentration (0.01% w/v) to highest lactose concentration (1% w/v) in the final medium. This medium was then employed in the optimization of the quick transformation protocol. We initially tried omitting both the heat-shock and regeneration steps. This resulted in a drastic reduction in the number of transformants per plate, with no significant gain in time (data not shown). The quick transformation protocol was also successful when using either freshly grown *E. coli* suspensions, or agar plate cultures. Due to the greater stability, of the agar cultures, and the need for a centrifuge, when working with cell

suspensions, we decided to adopt and optimize the protocol around the transformation of freshly picked cells from an LB-Agar plate, instead.

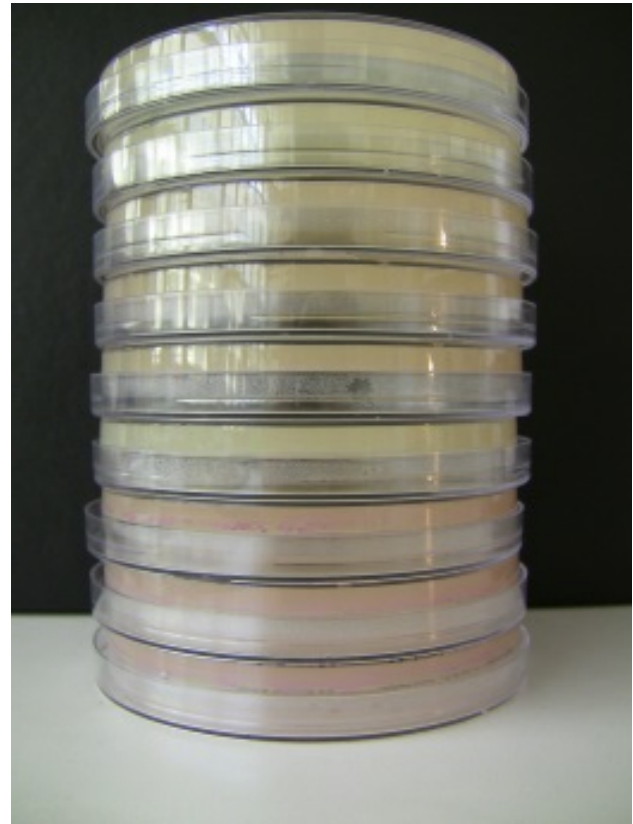

**Figure 1. We supplemented LB-A media with different glucose and lactose concentrations and mixtures. The resulting expression levels were as expected from normal Lac operon dynamics – increasing glucose concentrations resulted in reduced levels of pink coloration, while increasing lactose concentrations, increased the pink coloration of the bacterial colonies. Increasing the concentration of both sugars simultaneously resulted in a longer time for the pink coloration to appear (if at all). In this figure, LB-A plates with transformed bacteria. Plates are organized by glucose concentration, from highest (top plates) to lowest (bottom plates)**

DH5- $\alpha$  cells transformed by this method took longer to develop the pink coloration associated with mCherry expression. This could be due to the uptake of less DNA molecules per cell, as opposed to the utilization of the ultra-competent bacteria generally used in standard research laboratories. However, 48h at 37  $^{\circ}$ C proved to be enough for glucose consumption and mCherry expression in sufficient levels for macroscopic observation (Fig. 2).

Finally, the supplementation of the LB-Agar-



glucose-lactose plates with the X-Gal reagent, resulted in the development of a blue coloration of freshly transformed cells with the empty pSK vector. However, X-Gal supplementation and degradation of *E. coli* transformed with the pSK-mCherry recombinant plasmid resulted in the accumulation of both the pink and blue signals simultaneously (purple colonies) (Fig. 3).

#### 4. Discussion

*Lac* promoter-driven gene expression generally requires both the absence of glucose, and the presence of lactose, to reach high levels. There are two regulatory proteins involved in this process: catabolite activator protein (CAP) and Lac repressor (LacI). In this work, we have come up with a media formulation capable of showing the phenomenon of “catabolite repression”, which results in the inhibition of the *Lac* promoter, in the presence of glucose. Supplementation of the media with the lactose sugar resulted in an observable dynamics of catabolite repression vs promoter induction, which could be visualised by the pink coloration of the bacterial colonies, caused by mCherry expression and accumulation inside the cells.

When lactose is present in the bacterium’s environment, allolactose is produced, which binds to the LacI repressor, inhibiting its association with the promoter region, therefore releasing the physical space required for RNA polymerase to bind to, and transcribe the *Lac* operon. By contrast, when both glucose and lactose are present in the medium, a second type of control mechanism, termed “catabolite repression”, acts to prevent lactose metabolism. The Catabolite Activator Protein (CAP) forms a complex with cyclic AMP (cAMP) that activates transcription by increasing the affinity of the RNA polymerase for the *lac* promoter. The *lac* operon is positively regulated by cAMP and the CAP protein. In the absence of glucose, the cAMP concentration is high and binding of CAP-cAMP to the DNA significantly activates transcription by increasing the affinity of the RNA polymerase for the *lac* promoter. In the presence of glucose, a more preferable energy source, cAMP is low, and thus cAMP-CAP does not bind to the CAP site, resulting in a diminished affinity of the RNA polymerase for the *lac* promoter.

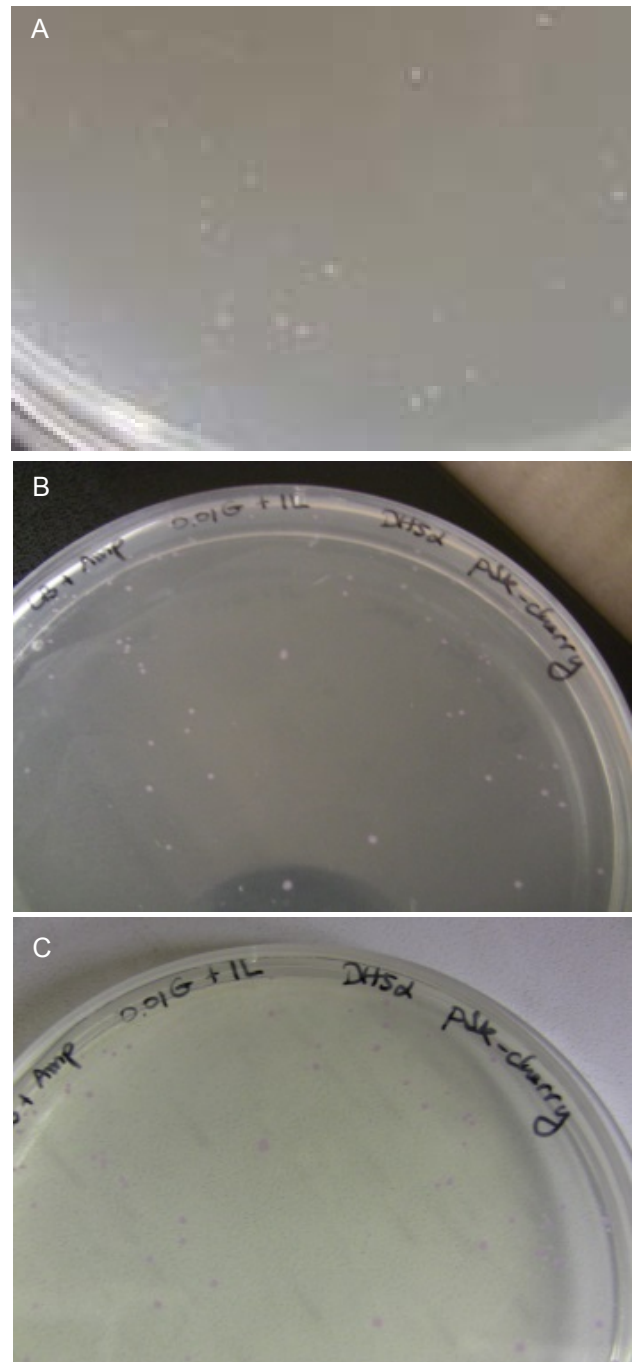

**Figure 2. DH5- $\alpha$  cells transformed with the recombinant pSK-mCherry vector, when plated in selective media supplemented with glucose and lactose, appear initially as white-cream colonies, after ON incubation at 37 °C (A). A pink coloration of the bacterial colonies becomes increasingly apparent with further incubation of the plates at 37 °C, with some colour being observable at 24h (B), and an obvious coloration at 48h (C)**

Through this mechanism, the cell is capable of measuring the presence and concentration of glucose, further inhibiting the transcription of the lactose metabolizing enzymes [1, 3].

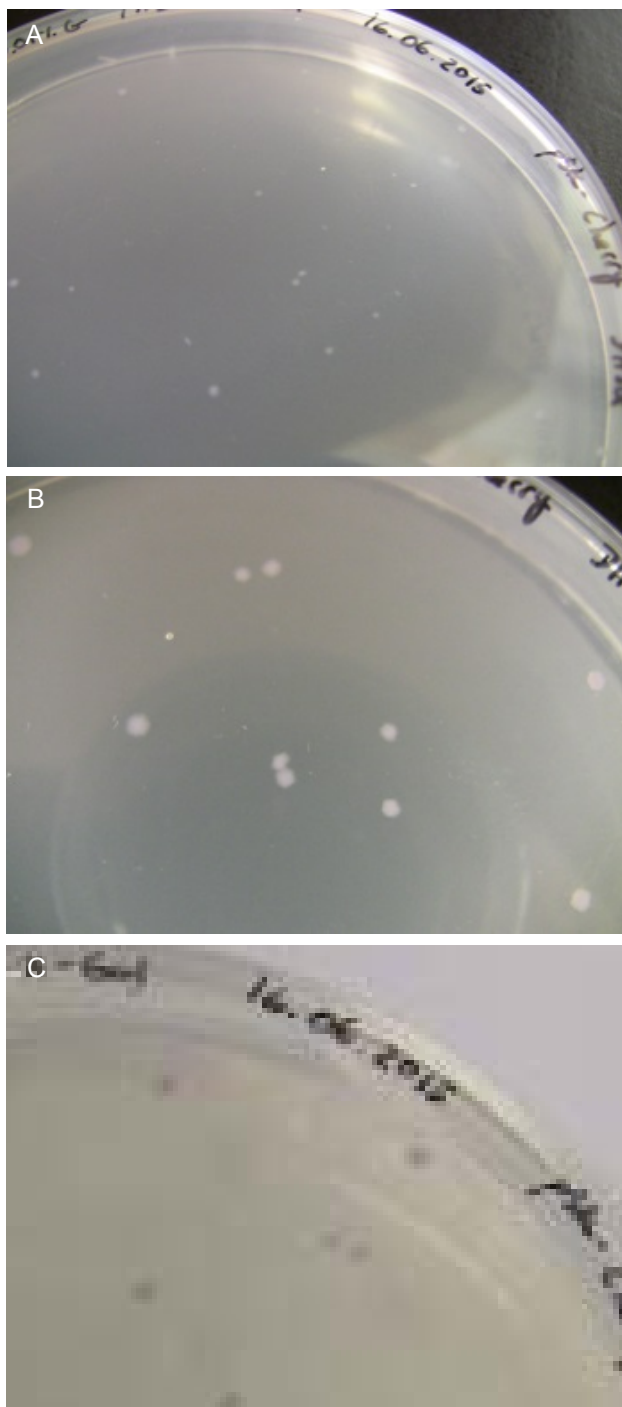

**Figure 3. Supplementation of the culture medium with X-Gal. For cells transformed with the recombinant pSK-mCherry plasmid, this media resulted in the combined expression of both reporter proteins, as a single molecule. Colonies are initially white, after ON incubation (A), the signal becomes faintly detectable after 24h of incubation (B). The simultaneous appearance of a pink and a blue coloration superimposed in the same colony, gives it a purple appearance after 48h at 37 °C (C)**

Isopropyl-beta-D-thiogalactopyranoside is the most commonly utilized Lac promoter inducer, since this synthetic lactose analog is

both a potent inducer and is not metabolized, its concentration remaining constant over time. This reagent is expensive however, and being a synthetic analog, many students find themselves struggling to associate its function with that of the inducer molecule. For these reasons, we have resorted to using lactose as the inducer, and have formulated a glucose-lactose supplemented LB-A medium, capable of both rapid and reproducible repression/induction of the *Lac* promoter.

By further complementing the culture media with the reagent X-Gal (5-bromo-4-chloro-3-indolyl-beta-D-galacto-pyranoside), the enzyme activity of the reconstituted  $\beta$ -galactosidase enzyme also becomes macroscopically observable. This enzyme degrades X-Gal into a blue-coloured precipitate, thus resulting in blue bacterial colonies. This mechanism is commonly utilized in research laboratories for easily detecting bacteria transformed with empty vectors, and is termed “ $\alpha$ -complementation”. In our work, the mCherry cDNA was ligated upstream and in frame with the vector’s LacZ gene. In practical terms, we have created what is called a “chimaera”, or “fusion protein”, in which two different proteins are synthesized as one (in this case an mCherry- $\beta$ -galactosidase fusion protein).

Both the mCherry and  $\beta$ -galactosidase remain functional in this fusion protein, and thus, both the pink and blue coloration develop simultaneously in the most complex media formulation tested (LB-A-glucose-lactose-X-Gal). This resulted in the appearance of lilac colonies, as opposed to the pink (mCherry only) or blue ( $\beta$ -galactosidase only) colonies. This particular characteristic allows for this activity to become very versatile for the teaching of biological concepts that range from basic notions of DNA and bacteria, the uptake of exogenous DNA by bacterial cells (genetic transformation, and transgenics), up to notions of fluorescent protein technology and fusion proteins, which are generally topics explored in a University setting.

## 5. Conclusion

We were successful in designing a simple and reproducible experimental setting for the genetic transformation of *E. coli* with a recombinant vector, containing an mCherry- $\beta$ -galactosidase marker.



Different media formulations, in which the concentrations of glucose, lactose and X-Gal vary, allow for the macroscopic observation of several biological phenomena: 1) catabolite repression, 2) *Lac* promoter activation, 3) enzymatic degradation of a colourless substrate into a blue-coloured precipitate, and 4) a functional fusion protein.

For these reasons, we are confident that this activity will prove to be an invaluable tool for the teaching of biology to students of very various levels, but particularly at a high-school to University setting.

## 6. References

- [1] Weaver RF. Molecular Biology – Fifth Edition. Mc Graw Hill; 2012.
- [2] Shaw K. Negative transcription regulation in prokaryotes. Nature Educ. 2002; 1 (1).
- [3] Lodish H, Berk A, Kaiser CA, Krieger M, Bretscher A, Ploegh H, Amon A, Scott MP. Molecular Cell Biology – Seventh Edition. Freeman WH and Company: New York; 2013.
- [4] Pierce B. Genetics: A conceptual approach. 2<sup>nd</sup> Edition. Freeman WH and Company, 2005.
- [5] Shaner NC, Campbell RE, Steinbach PA, Giepmans BNG, Palmer AE, Tsien RY. Improved monomeric red, orange and yellow fluorescent proteins derived from *Discosoma* sp. Red fluorescent protein. Nature Biotechnology 2004; 22 (12): 1567-72.
- [6] Casali N. editors. *Escherichia coli* Host Strains. Humana Press; 1995.
- [7] Sambrook J, Russel DW. Molecular Cloning: A Laboratory Manual, Third edition (Cold Spring Harbor Laboratory Press, Cold Spring Harbor, New York, 2001).
- [8] Singleton P. editor. Dictionary of DNA and Genome Technology – Second Edition. Great Britain: A John Wiley & Sons, Ltd.; 2010.
- [9] Mosher RH. Using pGLO to Demonstrate the Effects of Catabolite Repression on Gene Expression in *Escherichia coli*. Bioscene 2002; 28 (3).
- [10] Fonseca MJ, Tavares F. Natural Antibiotics: A Hands-On Activity on Garlic's Antibiotic Properties. The American Biology Teacher 2011; 73 (6): 342-6.
- 
- 
-

## Science Teaching in Primary School and the Importance of Interdisciplinarity in Knowledge Construction. Case Study: “Do Snails Prefer Cabbage or Lettuce?”

<sup>1</sup>P Varela, <sup>2</sup>V Martins, <sup>3</sup>A Moreira,  
<sup>1</sup>MFM Costa

<sup>1</sup> University of Minho, Portugal

<sup>2</sup> Carlos Amarante School Cluster, Portugal

<sup>3</sup> Sol Nascente Social Education Centre,  
Ribeirão, Portugal  
pibvarela@ie.uminho.pt,  
chedas74@gmail.com,  
anaisabel1990@hotmail.com,  
mfcosta@fisica.uminho.pt

**Abstract.** The way in which, traditionally, sciences have been taught in primary school has not allowed for the integrated use and development of the knowledge and skills acquired in the different curriculum areas. Therefore, it is necessary to promote a science teaching and learning process that encourages and enables the use of that knowledge in the context of different situations that are meaningful and relevant for children. With this goal in mind, this article seeks to illustrate, through the analysis of the process of exploration of the activity "Do snails prefer cabbage or lettuce?", which was conducted with a class of the 4th year of primary school, that research-based science activities enhance the integrated and meaningful use and development of knowledge and skills from other curricular areas, especially language and mathematics.

**Keywords.** Inquiry activity, Integrated and interdisciplinary approach, Science Education.

### 1. Introduction

The lack of time to complete curricular programmes has occasionally been employed as a justifying argument for the low level of commitment towards science teaching in our primary schools. Behind this argument lies the idea that there are priority skills, such as reading, writing and calculus, which are subject to assessment tests at the end of each primary school year, which are negatively affected when other curricular areas are addressed in

the classroom [1].

From a different perspective, Costa [2] points out that the way practical science activities have been conducted in the classroom indeed constitute a waste of time. He argues that, most of the times, these are used merely as an illustrative resource for what was transmitted by the teacher. In that case, “all of the discipline's potential for the development of transversal and specific skills is lost. This is why teachers say that these activities “waste a lot of time”, which is actually true because of the way they are used” [2, p. 34]. Indeed, when these activities are used in this way, the student takes on a passive role, fundamentally limited to the accumulation of knowledge. Learning loses relevance, and its personal and social use becomes ineffective.

Practical and investigative science activities provide a privileged context for the meaningful use and integrated development of the knowledge acquired in those curricular areas [4, 5]. Several authors argue that basic reading, writing and calculus skills are better developed when contextualised into other curricular areas and used as instruments at the service of those areas [1, 4, 6]. The recommendations that resulted from an expert meeting on science teaching in primary school, promoted with the endorsement of UNESCO in 1983, stated that: “Science can positively assist children in other subject areas, especially language and mathematics” [7, p. 7].

The understanding of numbers, orders of magnitude, mediation processes, etc. is considerably developed and reinforced when children apply those mathematical notions to the resolution of problems that emerge from Science activities. Similarly, these activities, when conducted in an environment of freedom of communication and respect for the opinions of others, give rise to situations that stimulate children to talk, communicate and discuss ideas, to describe, interpret, present and discuss the result of observations; they learn and use new, more suitable words to explain and organise their own ideas; elaborate written records, etc. [1, 4, 8]. Children feel a natural impulse for communication when they are engaged in learning experiences that are truly meaningful for them [1].

Children who are usually shy and/or show little interest become quite active and

communicative during the development of this kind of activities. From an identical perspective, Worth [8] points out that the students' linguistic skills are clearly developed when practiced within an appealing and significant context. Such a context is offered by the practice of inquiry-based science teaching, which promotes vast opportunities for students to become involved in the significant use of language. We agree with Sanmartí when he states that to, in order to learn Science, it is necessary that children: "(...) enjoy learning how to think, create theories, relate facts with those theories... And learn to talk, read, write, build charts and schemes... In other words, when they learn science, they learn to use language and mathematics" [9, p. 14].

Moreover, science learning must emphasise the establishment of links to other curricular knowledge, in contexts that are meaningful for students. This emphasis is consistent with the philosophical enquiry of the curriculum supported by Fisher: "The philosophical approach can enrich science not only through planning and review stages, but also in bridging science activities to other elements of the curriculum and to the world of everyday experience. Without this bridging or linking to meaningful activity in everyday life science will seem to have limited relevance, and instead of being something that helps children to make sense of their world will simply remain an imposed body of knowledge" [10, p. 200].

## **2. Objectives**

The traditional way in which sciences have been explored with primary school children tend to discourage the integrated use and development of the knowledge and skills acquired in the various curricular areas. Therefore, it is necessary to promote a science teaching and learning process that encourages and enables the use of that knowledge in the context of different situations that are meaningful for the children. To this aim, this article seeks to illustrate, through the analysis of the process of exploration of the activity "Do snails prefer cabbage or lettuce?", that inquiry activities entail the use of, and enhance the integrated development of knowledge and skills from other curricular areas, particularly language and mathematics.

## **3. Context of the practice and methodological options**

In a 4th-year class of a Portuguese primary school, comprised by twenty-five students, 13 boys and 12 girls, aged 8 to 9 years, several inquiry activities were explored by the two primary school teachers who co-author this article. In the classroom, the two teachers collaboratively and simultaneously took the roles of teachers and researchers. One of the activities was aimed at investigating the food preferences of snails, i.e., whether they prefer cabbage or lettuce. This activity was designed by Sá [1] and it aims at developing animal study skills, by means of systematic observation in controlled conditions by the students. According to the author, the snail is an excellent subject for study in the classroom: it is a friendly animal that children like; it is harmless; it is small; its mobility is very limited, so it can be observed slowly and carefully.

The data generated during the process of exploration of the activity in the classroom was collected in the form of field notes, audio recordings, pictures and records kept by the students, e.g., drawings and small written texts. This data was subsequently compiled in the form of class diaries - descriptive and reflective narratives on the most important events that took place in the classroom setting. The class diaries constituted both a data recording method and a strategy for reflection and for the modelling of the teaching-learning process [11]. It is based on the analysis of the diary on the activity "Do snails prefer cabbage or lettuce?" that this article presents the process of teaching and learning promoted in the classroom.

## **4. Analysis of the classroom diary**

Divided into small groups, students identify the basic aspects of the external morphology of the snail and investigate its food preferences - whether it prefers cabbage or lettuce.

### ***A. They communicate what they know about the snail.***

The students' initial knowledge focuses mainly on the external characteristics of the snail and on some of its behaviours: "it has a shell"; "it moves very slowly"; "it's sticky"; "it leaves a trail"; "it's got 'tiny horns', which are its eyes"; "its shell is brown and black"; "its shell is

soft for us if we step on it, but for other animals it's hard, and can serve as protection (Fábio); "when they're scared they get inside it; "only when something hurts it" (Joana G.).

### B. The groups observe the snail.

Each group is provided a snail inside a glass jar. Students observe the characteristics pointed out above and discover others, such as the respiratory hole located beneath the shell, and infer on its function: "I saw a hole, it must use it to get into the shell!" (Joana); "the hole is to let air in" (Inês); "it's for breathing"; "it's on the left side (Sofia)."

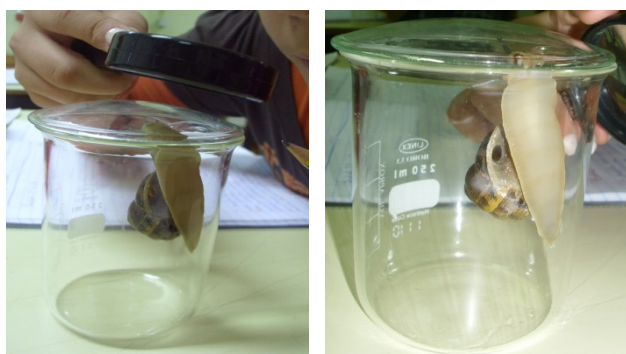

Figure 1. Observing the snail

### C. How does the snail move around?

Students visualise muscle contraction waves occurring on the underside of the snail's foot, as it moves inside a glass jar: "it has no legs" (Patrícia); "it moves in waves" (Gonçalo); "we can see some lines under it" (Sérgio); "the lines are moving". "The lines are on the foot and it looks like they go from one side to the other" (Fábio); "it's sticky and it shrinks and stretches" (Joana); "it leaves a trail when it moves, and when you pick it up, it shrinks into its shell (Inês)".

### D. The students make a drawing with captions.

After some discussion, some scientific information is inevitably provided on the functions of some of the snail's external structures. At the end, the students make a drawing with captions containing this information.

### E. What does the snail feed on?

The first answers include "grass" or "vegetables". However, when asked about what type of vegetables, they mention "cabbage"

(Guilherme) and "lettuce" (Carolina). Among these answers, there were those who raised the fact that the snail it is a "herbivore" (João).



Figure 2. Observing the muscle contraction waves

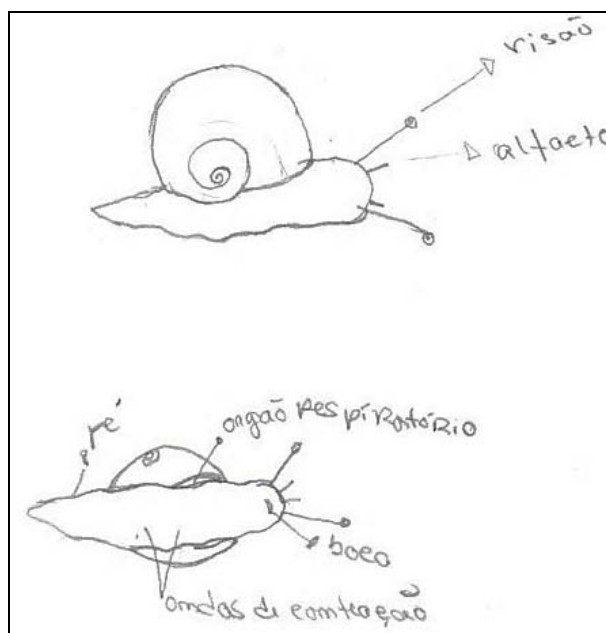

Figure 3. Drawing of the snail with captions

### F. They investigate the snail's food preferences.

The groups are now given the following challenge: "Does the snail prefer cabbage or lettuce?" To solve this problem, they discuss a research strategy, among themselves and with the teacher:

- o Students make predictions.

The class is asked to make predictions about the snail's favourite food. Most students predict that the snail will prefer cabbage (84%), while a minority says it will prefer lettuce (16%). The predictions are recorded in a table.

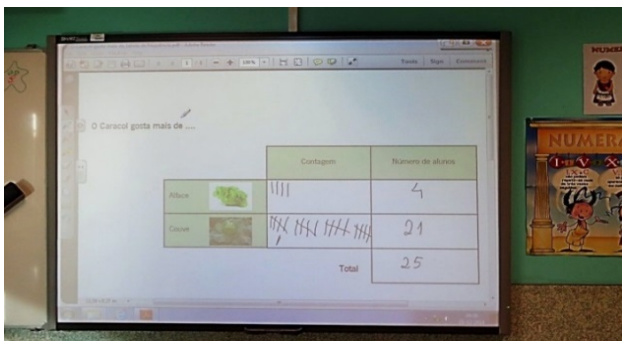

Figure 4. Record of predictions



Figure 5. Graphic representation of the predictions

- o The children prepare a bar graph.

The students prepare a bar graph with the data from the previous predictions. They count and calculate the difference in the predictions between the vegetable with the highest and lowest frequency - "seventeen" (Inês).

- o Each group builds a terrarium.

For the construction of the terrariums, students suggest the following materials: "earth" (João R.), "food" (Bruno) and "a box to put the snails in" (Inês). When asked about the type of "food," students refer "cabbage" and "lettuce", as the goal is to investigate which of these vegetables is preferred by the snail.

- o Students measure the initial amount of food to put in the terrarium.

The children answer the question: how will we measure the amounts of lettuce and cabbage eaten? The answer to this question implies that students know of a method of measuring the amount of food, so that, after a few days, they can find out

whether the snail prefers cabbage or lettuce. In the absence of ideas from the students, the teacher shows a sheet of squared paper as a way to catalyse the students' thought process and mobilise knowledge previously acquired in other curriculum areas - calculating areas through grids. The idea then arises to outline the leaves of cabbage and lettuce on the square paper in pencil: "we can draw and then count the squares, before and after (Guilherme).

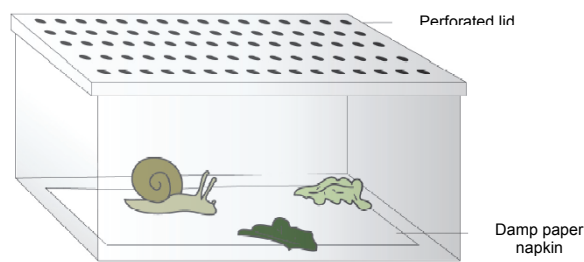

Figure 6. Illustrative example of a terrarium

The amounts of vegetables eaten are given by the difference between the number of initial squares and the number of squares remaining after two days.

- o They count and record the initial number of squares.

After outlining the leaves of cabbage and lettuce, the students count the initial number of complete squares. Incomplete squares are obtained by approximation. At the end, the leaves are placed in the terrariums along with the snails. The terrariums are then covered with perforated lids so that the snails cannot escape.

**G. After two days, they calculate the amount of food eaten by the snail.**

The groups use the same square-based measuring process and record the data in a table. Taking the initial and final number grid cells, each group calculates the amount of lettuce and cabbage eaten by the snail after two days, using the grid as a unit of measure.

Taking the data obtained in all the groups, the students calculate, on the classroom board, the average amount of food ingested by the animal during the two days it spent in the terrarium. They obtained the following average



results: lettuce 15.5 squares; cabbage 6.25 squares.

short, illustrated text on the activity and on their main learnings.

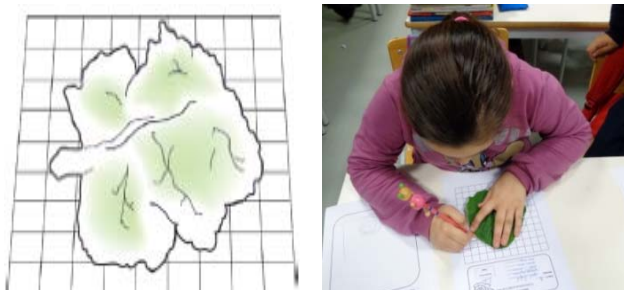

Figure 7. Measurement of the initial leaf area and their placement in the terrarium



Alimentos	Número de quadrículas no início	Número de quadrículas após a experiência	Número de quadrículas comida
	64	42	22
	70	65	5

Figure 8. Records prepared by the groups (in portuguese)

#### H. They interpret the data and draw conclusions.

The results obtained are not identical in all groups. In three of the groups, the snail ate more lettuce, whereas in one group, it ate more cabbage. However, because the investigation was carried out in 4 groups of students and, therefore repeated four times, it was possible to conclude, with reasonable credibility, that snails prefer lettuce, as, in the vast majority of cases, throughout the two days, they ate a greater number of squares of lettuce.

#### I. Illustrated record of the activity

By way of a summary, the students wrote a



Figure 9 Illustrated text on the activity

With contributions from the various individual texts, the following collective text was prepared:

#### Snails

"Snails are animals that have tentacles on their head". "At the tips of the longer tentacles, are their eyes". "The bottom tentacles are smaller and they smell through them". "Their shell is hard ... it serves as protection!" We also found that they have a very tiny mouth". "It also has a hole to breathe through". It produces a goo to slide over and makes little waves on the underside of its foot". "Snails are oviparous animals". "Between cabbage and lettuce, the food they prefer is lettuce." This was what we saw in the experiment we conducted in class". "In that experiment, we built a little house for the snail". "What we observed was that it eats both cabbage and lettuce, but prefers lettuce". "We enjoyed this lesson very much".

#### 5. Final considerations

Sciences are an area of knowledge that is, by nature, interdisciplinary, enabling the establishment of relevant links to other fields of knowledge. When properly explored in the classroom, science activities entail the use of, and at the same time, enhance the development of knowledge from other curricular areas, especially language and mathematics.

Currently, there is wide recognition of the importance of language in science learning as a tool for communication and joint construction of scientific meanings [12,13,14,]. In the teaching and learning process previously described, the children, in a context of social interaction, resort to the use of language to: a)



communicate and discuss their initial knowledge on the snail with their classmates; b) record, in writing, and orally communicate the details of their observations; c) describe, in their own words, some of the structures identified in the animal's body; d) share their inferences on the functions of some of those structures; e) learn and use new words, such as "tentacles", which they previously referred to as "tiny horns"; f) describe the snail's mode of locomotion and its reactions to certain external stimuli; g) communicate their predictions on the snail's favourite food to the class; h) discuss, with each other and with the teacher, a research strategy to obtain an answer on whether the snail prefers cabbage or lettuce; i) record their predictions; j) organise and record written and pictorial information obtained on the problem being investigated; l) prepare and communicate their findings; m) prepare an illustrated written text of the activity performed in the classroom, based on the individual texts produced.

All this discursive activity is generated in the classroom as a result of a learning process in which children are deeply involved and, therefore, their oral and written communication skills are developed in a more natural way. According to Vygotsky [15], written communication, for example, must be felt by the child as an inner necessity, in the context of meaningful and relevant activities. In this regard, Sá [1] points out that, for many children, writing an essay on the Sun, for example, is a painful and most likely unsuccessful task. But writing a story about a snail that they observed, describing the procedures they used in order to find out whether it prefers lettuce or cabbage, is talking and writing about a very intimate experience, in which there is effectively a personal and intellectual involvement by the children.

During the execution of the research strategy, in order to solve the problem with which they were confronted ("does the snail prefer cabbage or lettuce?"), the children, stimulated by the actions of the teacher, in addition to a whole set of mental processes, also activate and mobilise knowledge from the field of mathematics, namely: a) they organise the data on the predictions made in a two-way table; b) with this data, they build a bar graph; c) they interpret the information contained in the graph and calculate the difference between

the vegetables with the highest and lowest prediction frequency; d) they measure the area of pieces of cabbage and lettuce leaves using a square grid; e) they count the total number of squares at the beginning and end of the study; f) they calculate the amounts of food consumed by the snail, taking the difference between the initial and final number of squares; g) they calculate the average amount of food ingested by the animal, using the data obtained by the various groups of students.

Learning sciences in this way promotes the mobilisation and the contextualised development of knowledge acquired in other curricular areas, as, according to Perrenoud [16, p. 32]: 'Classic school exercises allow for the consolidation of the notion and the algorithms of calculus; it does not work on transference. (...) Frequently, the fundamental notions have been studied in school, but removed from any context. They are, therefore, a "dead letter", like fixed assets with which we cannot make informed investments'.

The mobilisation and use of all these knowledge and skills constitute important resources for the process of building scientific meanings, which, in turn, are particularly well developed when contextualised within concrete situations that have a deep meaning for the students, as can be the case with science activities. Therefore, in order to ensure a genuine understanding of the contents of the various fields of knowledge, these must be meaningful for students. It is sometimes argued that, as students advance in school years, they lose the abilities of writing, reading and calculus. In this regard, Gardner [17] points out that students 'do not lose those abilities, but rather the opportunity for productive use in meaningful contexts for them'.

Inquiry activities, such as the one described in this article, can favour the development of an integrated pedagogical practice, where the different areas of curricular knowledge become relevant and meaningful for the children. The goal is, therefore, to promote a practice that encourages and enables the mobilisation of these resources and knowledge within concrete, contextualised situations that have a deep meaning for children. However, the mobilisation of knowledge does not occur automatically, it is acquired by the exercise of a reflective practice in situations that allow for the mobilisation, transposition and combination of

knowledge [16]. It is that contextualised reflective action in concrete situations that imparts meaning and relevance to curricular knowledge.

## 6. References

- [1] Sá J. Renovar as Práticas no 1º Ciclo Pela Via das Ciências da Natureza. Porto: Porto Editora; 2002.
- [2] Costa F. As actividades práticas na educação em ciência: uma oportunidade perdida? In: Hamido, et al., (Orgs.), Transversalidade em educação e em saúde. Porto: Porto Editora; 2006, p. 31-38.
- [3] Sá J, Varela P. Das Ciências Experimentais à Literacia: Uma proposta didáctica para o 1º ciclo. Porto: Porto Editora; 2007.
- [4] Harlen W. Enseñanza y aprendizaje de las ciencias. Madrid: Ediciones Morata; 2007.
- [5] Hammerman E, Musial D. Integrating Science With Mathematics & Literacy. New Visions for Learning and Assessment. Thousand Oaks, California: Corwin Press; 2008.
- [6] Dyasi HM. Visions of Inquiry Science. In: R. Douglas R, et al., (Eds.), Linking Science & Literacy in the K-8 Classroom. Arlington: NSTA Press; 2006, p. 3-16.
- [7] Harlen W. Science as a key component of the primary curriculum: a rationale with policy implications. Perspectives on education Primary Science, 1, 4-18. London: Wellcome Trust, 2008.
- [8] Partridge J. Conducting a science investigation in a primary classroom. Teaching Science 2006; 52 (2); 44-45.
- [9] Sanmartí N. Un reto: mejorar la enseñanza de las ciencias. In: Catalá, et al., (Eds.). Las ciencias en la escuela. Teorías y prácticas. Barcelona: Editorial Gráo; 2002.
- [10] Fisher R. Teaching Thinking: Philosophical Enquiry in the Classroom. London: Bloomsbury Publishing Pic; 2013.
- [11] Zabalza MA. Diarios de clase: un instrumento de investigación. Madrid: Narcea; 2004.
- [12] Rivard LP, Straw SB. The Effect of Talk and Writing on Learning Science: An Exploratory Study. Science Education 2000; 84, p. 566-593.
- [13] Català M, Vilà N. Las funciones lingüísticas en el proceso de adquisición de los conocimientos científicos. In M. Catalá, et al., (Eds.). Las ciencias en la escuela. Teorías y prácticas. Barcelona: Editorial Gráo; 2002, p.89-103.
- [14] Aleixandre, JM. Comunicación Y lenguaje. In J. Aleixandre (Ed.), Enseñar ciencias. Barcelona: Editorial Graó; 2003, p.55-71.
- [15] Vygotsky LS. Pensamento e Linguagem. São Paulo: Martins Fontes Editora; 1987.
- [16] Perrenoud P. Porquê construir competências a partir da escola? Desenvolvimento da autonomia e luta contra as desigualdades. Porto: Edições ASA; 2001.
- [17] Gardner H. La mente no escolarizada. Cómo piensan los niños y cómo deberían enseñar las escuelas. Barcelona: Ediciones Paidós, 1993.
- 
-

## Syntax and Biology: a Teaching Experience with the Laboratory Notebook

*H Rebelo, D Aguin-Pombo  
Universidade da Madeira, Portugal  
helenreb@uma.pt, aguin@uma.pt*

**Abstract.** In the 1st Cycle of Primary Education at the University of Madeira, preservice teachers have different courses including Portuguese and Natural Sciences. Education in Portugal from primary school to university level follows a unitary pedagogy circumscribed to every discipline rather than a global approach. We believe this pedagogic approach could benefit from an entirely different organization in which, instead of having a fragmented program, would have, when possible, pedagogical proposals and knowledge together. We demonstrate the usefulness of this interdisciplinary approach, bringing together two areas of knowledge (Syntax and Biology) that generally consider themselves apart, but that have much to give each other for the benefit of students and pupils at primary schools.

**Keywords.** Syntax, Biology, Laboratory Notebook, Pedagogy, Preservice teachers.

### 1. Introduction

In the occidental contemporary education systems like the Portuguese, it is common to separate, from elementary to higher education, Science teaching from Arts and Humanities education. However, in the past, as, for instance, was stated by the philosopher Anselmo Borges [1], these two branches of knowledge were together. This may explain why, presently, most science students never interconnect these two areas of knowledge and believe that what they learn when studying language like Portuguese is not useful and important for learning Sciences. The opposite is also true for students interested in Humanities. For instance, in the elementary school lessons in mother language, students develop writing and reading skills that have to be used in Science lessons but they rarely joined knowledge of both. In a different sense, but perhaps with the same purpose, the authors of "New Directions in Language and Science Education Research" [2] show the relevance of writing in school science lessons. These

authors focused their research on Higher Education students and, showed, indirectly how important is to write well -syntax knowledge- and to write in Science research:

"Writing is an essential feature of all science-related endeavors, such as health care, agriculture, computing, and engineering, as well as the work of professional scientists. Practitioners of science regularly write in a variety of forms including personal notes, memos, diagrams, graphs, grant proposals, and reports. Effective use of different writing forms to address specific purposes with various audiences is part of the fundamental sense of science literacy in which students are expected to «become competent at communicating experimental methods, following instructions, describing observations, summarizing the results of other groups, and telling other students about investigations and explanations» (National Research Council, 1996, p. 148). Writing in science classrooms serves two primary learning purposes: enculturation of learners into the discourse practices (genre perspective) and personal engagement of learners (diversification perspective)"

At the "Concluding remarks" [2], these authors explain:

"A growing number of science educators are now aware of the importance of the research being conducted by colleagues in the language and literacy research community. The Island Conference (funded by the National Science Foundation, Iowa State University, and the University of Victoria and attended by cognitive scientists, literacy researchers, science educators, and graduate students from Australia, Canada, Italy, the United Kingdom, and the United States) focused on linking these researchers, enculturating the next generation of researchers, and generating a number of issues and controversies for future literacy and science education research, teacher education, and classroom practice."

Science students, as well as preservice school teachers, need to be proficient in their mother tongue or another language they want to use, especially when they have to communicate the results of their research. Regarding, the mother language, school teachers need to understand the language *per se* to teach children to write and read.

However, on pursuing this goal, teachers often separated language from science lessons.

The origin of this dual conception of knowledge is probably related to the curricula promoted by the national educational systems that separate lessons of Science from Art and Humanities. In Portugal, after completing the first nine school years of elementary education, students have to choose between Humanities and Sciences. However, at the primary school, during the four first years, children have the same teacher for Portuguese, Natural Sciences, History and Mathematics. Thus, the teacher can construct and promote a unitary vision of knowledge. In contrast, when students have separate lessons for different disciplines and use different textbooks, the knowledge become fragmented. Why this does happen? Perhaps it is because the university curricula for teacher education have separated all these subjects. Once a student becoming a teacher, it is likely he reproduces the same method, switching from one subject to other using different textbooks. This common trend occurs also at the University of Madeira (UMa), in the undergraduate and master of teacher education. Here students have different courses including Portuguese (Basic Syntax: Portuguese III) and Natural Sciences (Environmental Studies IV - Biology). In the course of Portuguese they learn the language using often literary texts but the scientific discourse is not analyzed. Similar guidelines are evident, for instance, in the National Reading Plan ("Plano Nacional de Leitura") that recommended essentially literary books for children to read.

As a result of this, it is common that the language subjects such as Syntax and Natural Sciences as Biology never connect together. Is it possible to teach language using scientific texts? Primary school children can learn and improved knowledge from these two different areas at the same time, but, for this, preservice teachers need to consider this learning conception. For instance, when a child describes a butterfly in his science lessons, he is improving also writing and he also needs to use syntax. What a child learns about sentence structure in his mother tongue will be necessary for his writing practice in natural sciences. Therefore, it will be important to find a way to put together knowledge of Sciences and Humanities that promote meaningful learning. If

the teaching strategy is useful the same text can be used for teaching language and many other scientific matters such as Physics, Chemistry or Geology.

Undergraduate students, future teachers, at the University of Madeira, in the course of Portuguese III, enhanced their knowledge of Syntax, through literary texts. In the Environmental Studies IV (Biology) course, they conceive a laboratory notebook in which students describe observations and report the experimental activities performed in the laboratory lessons. Can students, future teachers, take advantage of notebooks to learn and teach Portuguese, namely syntax? From our point of view, this not only is possible but desirable. We propose to demonstrate that such an interdisciplinary approach, bringing together two areas of knowledge, often considered unrelated, can benefit both, preservice teachers and elementary students. Our purpose was to understand the opinion of future primary school teachers concerning the use of science texts to teach Syntax to children. Specifically we wish to know what students prefer most, scientific or literature texts, and which think to be the best for this purpose.

## **2. Laboratory notebook**

The guidelines for science teaching in elementary school suggest that children should have specific science skills. It has been stressed the need for teachers to be able to guide students in conducting science investigations. However, to implement these new science curricula, school teachers should have competences in experimental science. An essential part of science learning is to communicate the results of observations and findings. Thus, writing a laboratory report is regarded as an important part of teacher education. In the course on Environmental Science IV (UMa), notebooks were used as a pathway for students to learn through an inquiry-based method. In this course students have to write up a laboratory report of each of the 12 lab sessions performed during a semester. At the beginning of the semester, future teachers were given the guidelines to prepare individual lab reports and an evaluation grid with the items that will be assessed: question to be answered, objectives, hypothesis, materials, methods, procedures, results, discussion and conclusion. The

procedures developed during lab activities included mainly descriptions, comparisons, and inquiry-based science investigations. Notebooks were prepared during lab activities and remained in the lab after the lessons.

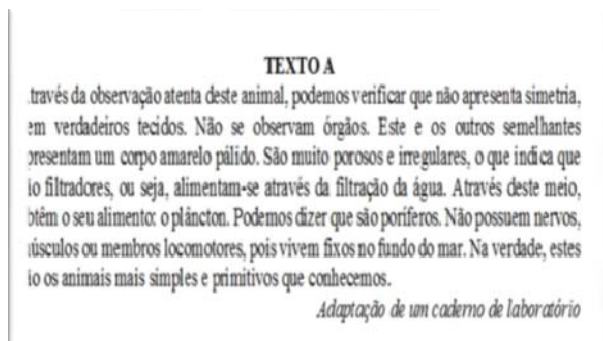

**Figure 1. The text A (laboratory notebook)**

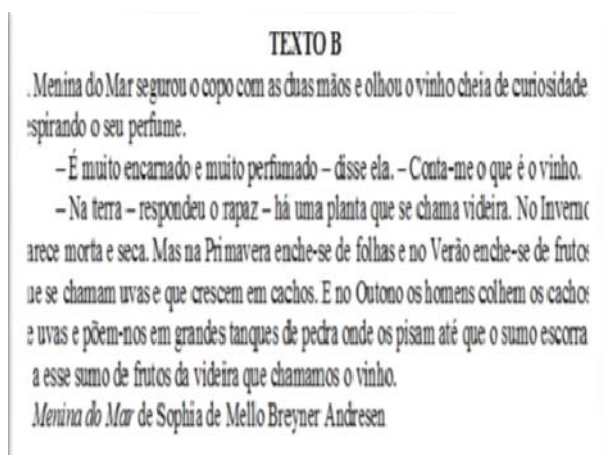

**Figure 2. The text B (children's literature)**

### **3. Methodology: the test and the questionnaire**

In the course of Portuguese III at UMa students learn Syntax. At the end of the Portuguese III course, during the lesson period, students were asked to answer a questionnaire and an elementary syntax test on two different texts: a science (A) and a literary (B) text. The questionnaire aimed to evaluate the students' opinion on the use of the two texts to teach syntax. The test evaluated their knowledge on syntax and verified in which of the two texts (A or B) students had more difficulties in the analysis.

#### **3.1. The test**

The test consisted of four syntax questions on two texts excerpt (A and B). Text A was an extract of a laboratory student's notebook performed in the course of Environmental Sciences IV (Biology) by a student of the

teacher education course. This text described the characteristics of a sea sponge observed during laboratory lessons. The students were informed that the text A was produced by a student of the teacher education course. The text B was an extract of a literary book, *A Menina do Mar* written by Sophia de Mello Breyner Andresen [3], a Portuguese Children's literature writer. This book is used to study language in the Portuguese III classes. In this book, by means of poetry, a little boy explains in his words to a new friend how the wine is made and its flavor is. This book and the text extracts were chosen randomly.

In the test questions, the students have to identify all the sentences, to count them, to classify the structure of the sentences into simple or compound/complex ("complexas"), to identify the sentence clauses and the subject and predicate in all.

#### **3.2. The questionnaire**

The questionnaire consisted of seven questions, four related to the students identification (sex, age, nationality, name and year of the studied course) and three critical thinking questions about the students opinion on which of the two texts was the best to teach syntax to children. The first of these three questions aimed to know which of the two texts was considered easier to analyze by students and why they believed to be less difficult. The second question inquired students what of the two text types would prefer to teach Portuguese Syntax to 8 and 10 years old children. The last question asked students whether they believe that textbooks of Environmental Sciences ("Estudo do Meio") could help elementary school children to study Portuguese language. In the three questions students were asked to justify their answer. The results presented here include the analysis of the responses to all questions except the last question of the test.

### **4. Results and discussion**

#### **4.1. Answers to questionnaire**

As whole 46 students -one male and 45 females- answered the test and questionnaire. The student group inquired was rather homogeneous concerning age and professional experience. About 50% of students were below their twenties, about 43% were between 21 to 29 years old and 7% where in their thirties or

older. Most of them had no professional experience in teaching. Many were full time students from Madeira (85%).

About half of students (57%) considered the literature text (B) the easiest to analyze. They argued that the literature text was easier because the boy and girl in the story used simple vocabulary commonly used by children. In contrast, 39% of the students selected the science text as the easiest (Fig. 3).

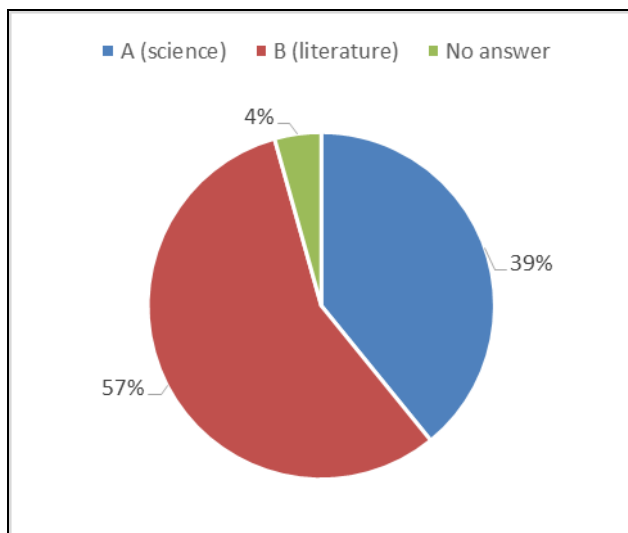

Figure 3. Number of students that answer to the question: which of the two texts (A or B) is easier for syntax analysis?

When students were asked which of the two texts would prefer to teach Portuguese to 8-9 year old children, 67% of the students said that would prefer the text B (literature) (Fig. 4). Of all students, only 22% select text A which reveals a growing interest in using other texts rather than literature ones. The remaining 7% believed that both texts can be used to teach Syntax. However, despite being 29% a small percentage, such positive trend towards science texts, is a surprising result taken into account that Portuguese language is taught almost exclusively based on literature texts from Elementary to Higher Education.

The last question concerning whether students would prefer to use natural science textbooks, particularly excerpts of biology, to teach syntax to children in the future, 77% of the students believed that science texts represent a good resource to teach syntax to children (Fig. 5). Only 4% of the students believed that scientific texts are useful to teach syntax but not all scientific texts. These results are important to understand the student's

perceptions of who are preparing to be teachers at children level education.

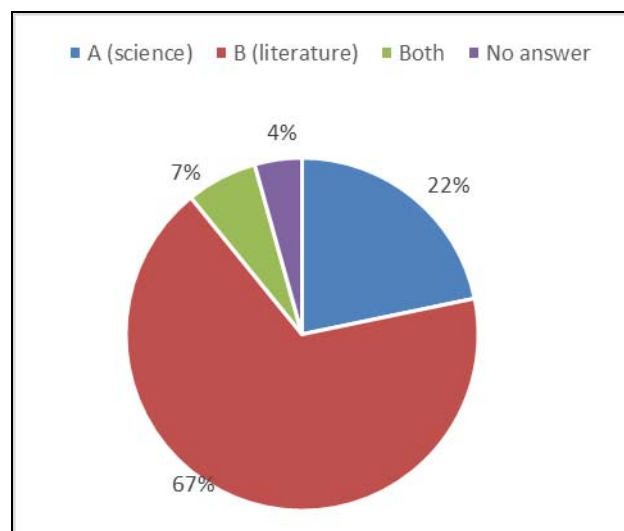

Figure 4. Percentage of answers to the question: which type of text (A or B) would you prefer to teach syntax to children?

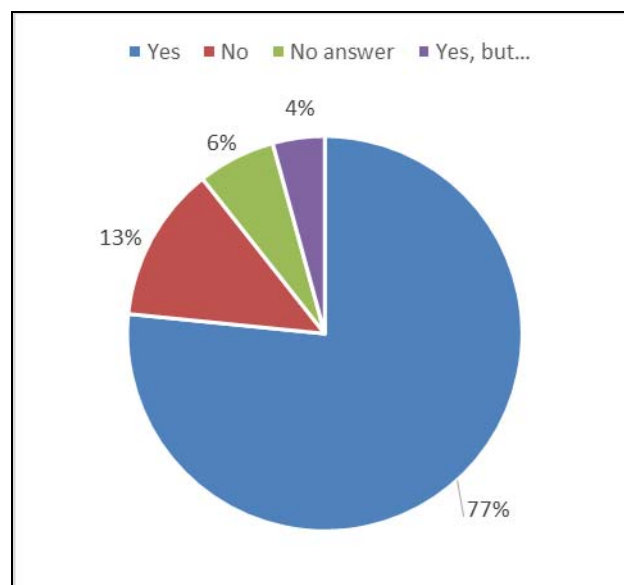

Figure 5. Percentage of answers to the question: Do you believe that environmental science textbooks could help elementary school children to study of syntax of Portuguese language?

#### 4.2. Answers to the tests

From the answers to the first question: How many sentences there are in texts A and B? it was found that all students analyzed correctly the text A but not the text B. The results revealed that students have more difficulties to analyze the syntax of text B than text A. They identified 8 sentences in each text. However, because of direct speech, text B has two additional *embedded sentences* ("frases encaixadas") [6] not recognized as such by



students. Thus, while the text B has 10 sentences, the text A has only 8 (Tab.1). In this case, most students fail to analyse direct speech correctly. Almost all students (45 of 46) failed to identify the number of sentences of text B while 95,6% of the them identified correctly those of text A (Fig. 6).

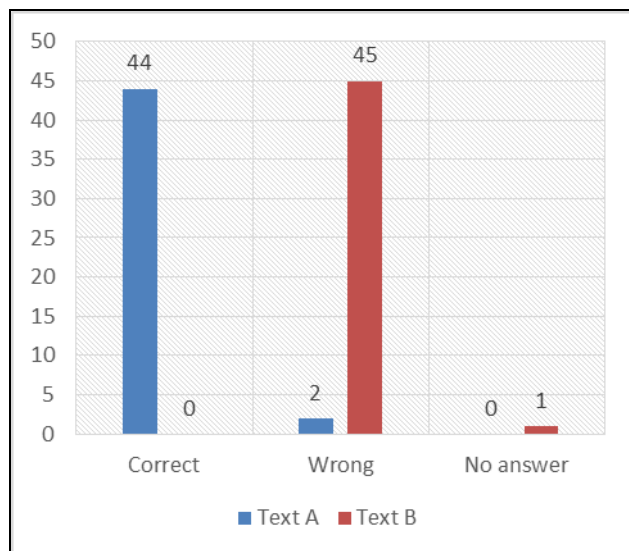

**Figure 6. Number of wrong and correct sentences identified by students in text A and B**

Although most students believed that the literature text was easier to teach syntax to children (Fig.3). Text B was more difficult for them, regarding the identification and the counting of the sentences. Almost all students (45) gave a wrong answer to this question. No student was able to identify the *embedded sentences* or count them correctly. The way in which direct speech is written, makes often difficult for the students to perform syntactic analysis. For instance, in the excerpt “– É muito encarnado e muito perfumado – disse ela.”, if we think about who is speaking, we see that there are two persons involved: one is the narrator, who tells what the little girls says, and the other is the little girl herself. This explain in part why in this case we should considered two sentences instead of one.

Teachers need to know how to analyze direct speech because children have to learn its syntax. The guidelines for the Portuguese language at Primary School level give relevance to listening, speaking, reading, writing and grammar. Elementary Syntax is part of grammar content. For instance, children need to understand what is a “sentence” and for this grammar books are essential tools for teachers. In the Portuguese III course, students

are recommended to read many syntax studies and use, at least, two different grammars [4] and [5]. Children have to know a simple definition of sentence: it is a sequence of words that is complete in itself. But they have to be able to identify them. Thus, they need to know that simple sentence contain one subject and predicate and convey a statement, a question, an exclamation, or a command. Many times, a sentence has two or more clauses or phrases. The sentence is the unit of the text. When it is written, it begins with a capital letter and finish with a full stop, but it can be replaced by a question mark or an exclamation mark. At the same time, the children have to learn what the subject and the predicate are, and also what is a clause or a phrase. For this reason it is important to know the different sentences types. In Portuguese, there are two general structures. The sentence can be classified into:

- *simple* (“simples”), when contains a single, independent clause, with one predicate;
- *compound* (“complexa por coordenação”), when has two independent clauses that are joined by a coordinating conjunction;
- *complex* (“complexa por subordinação”), when it contains an independent clause plus one or more dependent clauses and
- *compound-complex* (“complexa por coordenação e subordinação”), when has three or more clauses, for instance, when two are independent and one is dependent. All these issues were assessed in the test.

If we compare the structure and number of sentences of both texts, we verify its syntax is rather complex (Tab. 1). How many sentences can we find in both texts? Text B has more compound/complex sentences (“frases complexas”) than text A, that is, more compound, complex and compound-complex sentences than simple sentences.

In the text A, the sentence with more clauses and also more difficult to analyze was the forth that has four clauses: “São muito porosos e irregulares, o que indica que são filtradores, ou seja, alimentam-se através da filtração da água”. In contrast, the text B has two sentences with four clauses each. The first, was the eighth sentence (tab. 1 and fig. 7): “Mas na Primavera enche-se de folhas e no Verão enche-se de frutos que se chamam uvas e que

crescem em cachos.”. The second sentence was the ninth (tab. 1 and fig. 9): “E no Outono os homens colhem os cachos de uvas e põem-nos em grandes tanques de pedras onde os pisam até que o sumo escorra”.

Texts	simples sentences	compound and complex sentences
TEXT A	2, 3, 5	1, 4, 6, 7, 8
TEXT B	2, 7	1, 3, 4, 5, 6, 8, 9, 10

**Table 1. Number of simple, compound and complex sentences in both texts**

Although grammar can be teach to children without any text, most teachers use literary texts for this purpose. Sometimes, this is not the most suitable and easy way to explain children these contents. Nevertheless, the teacher is so familiar with literature texts that do often not want to use others. Teachers choose texts from language textbooks and would rather prefer them than would look for another even if it is easier for children. The results of this questionnaire and test showed that a literary text can be more difficult to analyze syntactically than a scientific one (Fig. 8). Almost all students were able to identify the correct sentence with more clauses in the text A but not in the text B. For example for text B, 39% of the student choose sentence 8 and 41% choose sentence 9.

These results clearly suggest that students could benefit if, instead of a having a fragmented disciplinary organization of curricula, had a different system that, whenever possible, pedagogical proposals and knowledge could be merge together. For example they could began analyzing scientific texts produce by children in science lessons, that are simpler than literature ones. After this first experience they could switched to literary or other kind of texts that are more complex, even if they are excerpts of children’s literature books.

The results of this inquire support our hypothesis: Syntax and Biology can be taught and learnt using the same text. So what would happen if Natural Sciences and Humanities are joined together in the education curricula? What kind of benefits would be expected if humanities and natural sciences become

allied? The knowledge acquisition would be probably better. For instance teaching grammar and syntax will be easier. Writing scientific texts and communicating science would also improve. Children and preservice teachers could benefit if Science and Humanities become allied in education system.

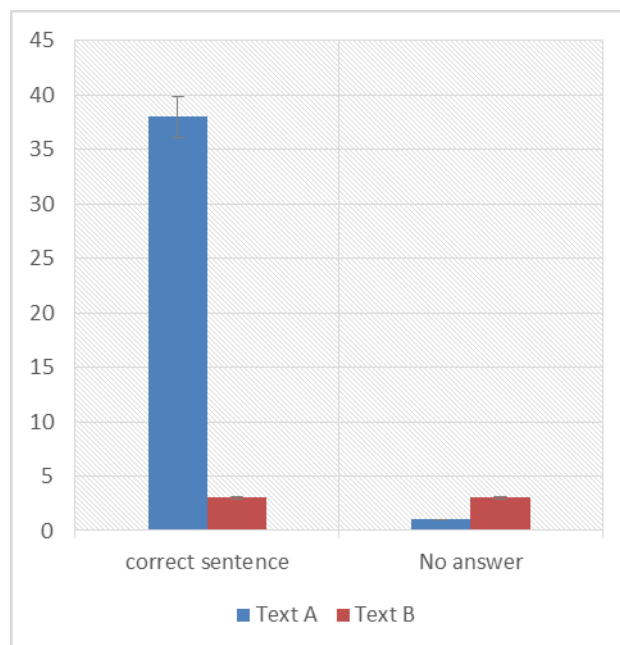

**Figure 7. Number of students that identified the correct sentences with more clauses**

## 5. Acknowledgements

We wish to thank the students that participate in this study.

## 6. References

- [1] Borges A. Português e Matemática. In: Diário de Notícias; 22-09-2009. p. 66.
- [2] Larry DY, Hand B, Goldman SR, Hildebrand GM, Osborne JF, Treagust DF, Wallace CS. New Directions in Language and Science Education Research. Reading Research Quarterly 2004, 39 (3): 347-352.
- [3] Andresen SMBr. A Menina do Mar, Porto, Figueirinhas; 1983.
- [4] Cunha C, Cintra LFL. Nova Gramática do Português Contemporâneo, Lisboa, Sá da Costa; 1995.
- [5] Mateus MHM. *et alii* Gramática da Língua Portuguesa, Lisboa, Editorial Caminho, 6ª ed.; 2003.

- [6] Rebelo H. A sintaxe de António Aragão em *Um Buraco na Boca*. Análise de uma amostra. *Cibertexualidades 7*, convocando "Estudos sobre António Aragão", Torres, Rui (org.), Universidade Fernando Pessoa, 2015, p. 95-108.
- 
-

## Development of Children's Attitudes and Knowledge Towards Insects: the Pedagogical Role of School Visits to Exhibitions

D Aguín-Pombo<sup>1</sup>, A França<sup>1</sup>, AV Bento<sup>1</sup>,  
J Azevedo<sup>2</sup>

<sup>1</sup>Universidade da Madeira, Portugal,

<sup>2</sup>Universidade do Porto, Portugal

aguin@uma.pt, anakot@uma.pt,

bento@uma.pt, azevedo@letras.up.pt

**Abstract.** School visits is a common non-formal science education strategy used regularly by teachers to call students attention and develop positive attitudes towards nature. The purpose of this study was to understand whether 6-14 year old school children gained positive knowledge and attitudes towards insects and science after visiting an exhibition of live insects from different parts of the world. Two questionnaires with nearly identical items were applied before and after the visit, to 182 elementary school students. The results showed that positive attitudes towards insects and animals increase after the school visit but the knowledge gained was below expectations. The importance of pedagogical planning is discussed.

**Keywords.** Attitudes; Biodiversity; Field trips; Insects; Non-formal Education; Science education.

### 1. Introduction

Recent research claims that we are facing the sixth mass species extinctions. A growing body of evidence suggests that present rates of species extinctions are higher than the pre-human rates [1], [2]. Positive attitudes towards biodiversity conservation are essential to prepare future generations to face the challenges of the current global biodiversity crisis. Citizens need to be aware of the importance of living things and become actively involved in preserving nature from the earliest age. As such, biodiversity has become a fundamental issue across Basic and Secondary Education school curricula. Insects due to their overwhelm diversity and abundance have a crucial role in natural ecosystems. Despite this, they rise little interest and attention to most people, in part because they are regarded as harmful to humans and their assets. Besides children are often taught to dislike insects and

to kill them whenever encounter them.

Most invertebrates are often seen by the general public with aversion, anxiety and ignorance [3]. Eagly and Chaiken [4] define human attitude as a "psychological tendency that is expressed by evaluating a particular entity with some degree of favor or disfavor". Thus, what people feel and believe about the environment determines their attitudes toward it [5]. Negative attitudes are difficult to change and represent a challenge to implement conservation programs, particularly in small, vulnerable biodiversity rich areas such as Madeira archipelago. In these oceanic islands the insects constitute about 78% of the known terrestrial biodiversity and nearly 23% of all taxa are endemic (~800 species). Conservation of these unique native island ecosystems is largely depending on the knowledge and positive attitudes of its inhabitants towards nature conservation. It is generally agree that the attitudes and behaviors in relation to nature must be understood and often influenced to avoid a greater harm to biodiversity. In fact, we need more knowledge about the development of the attitudes of children and adolescents in relation to nature. The pedagogical knowledge transmitted in the early years of education can have a very important role in changing attitudes of future citizens in relation to biodiversity. At schools, insects are used as examples to teach key concepts and process such as the circulatory and respiratory systems. However, after learning, students are still unfamiliar with insects, and have many misconceptions [6]. In science, field trips [7], visits to museums and zoos [8] and other types of learning activities (non-formal or informal) are regarded as useful to increase children's knowledge and motivation to learn [9].

Several authors described field trips as student experiences outside of the classroom at interactive locations designed for educational purposes [10], [11]. Through field trips students are taken to unique places that cannot be duplicated in the classroom. Each student can observe local and natural beings and create relevant personal meaning from their experience. Science school field trips include the visit to a variety of cultural institutions, such as natural history, and science museums, as well as zoos, and botanical gardens. In addition to stimulate new knowledge, these study visits can increase positive attitude towards science,

wake interests and provide many benefits for teachers and students [12]. The objective of this work is to understand whether students' knowledge and positive attitudes towards insects increase after visiting a study visit to an insect exhibition.

## **2. Methods**

### **2.1. Exhibition purpose**

The exhibition entitled *Living Insects from around the World* had as main purpose to show insect diversity to the general public and to grow the public interest towards insects. It was held at the University of Madeira (Funchal) between the 29th November 2007 and the 10th January 2008. Insect species were exhibited isolated in terrarium glass cages and the number of species displayed varied from 60 to 70 along the exhibition period. The exhibition included species from all over the world with representatives of various groups of insects like butterflies (Lepidoptera), praying mantis (Mantodea), stick insects (Phasmatodea), beetles (Coleoptera), locusts (Orthoptera), bugs (Hemiptera) and cockroaches (Blattodea). In addition were exhibited some specimens of non-insect arthropod groups like spiders (Araneae) and scorpions (Escorpiones).

### **2.2. Construction of Questionnaire**

Two questionnaires with nearly identical items were applied: one was given to the student visitors before seeing the exhibition (Questionnaire A) and another was answered by the students after visiting the exhibition (Questionnaire B). The students were accompanied during the visit by their teachers and the exhibition was part of the student's lesson period.

Both questionnaires consisted of the same number of questions, a total of 20. The questionnaire A has three blocks of questions. The first block (7 questions) aimed to characterize the students; the second block dealt with students interest and attitudes about insects (3); the third block (4) assessed specific knowledge about insects; the fourth block (6) evaluated the students interest for the natural sciences: stars, planets and universe (1), origin and evolution of life in Earth (1); how insects live (1), animals from different parts of the world (1), how human body is made and works (1), how dinosaurs live and why they disappeared

(1). The second questionnaire (B) has also 4 blocks of questions, those of the first two and last blocks were the same as in questionnaire A. The third block asked the students what they insects liked most and what they have learned from the exhibition.

### **2.3. Participants**

The study was conducted between November 2007 and January 2008. A total of 182 elementary school students (92 boys and 90 girls) aged 6 - 14 years old from first to the ninth grade attending two urban schools (Santa Teresinha and Salesian School of Arts and Crafts) and one rural elementary school (Prof. Francisco Barreto) participated in this study. The school of Santa Teresinha included 75 students of the fifth grade (age 9-11), the Salesian school included 78 students of the second grade (age 6-8) and the Prof. Francisco Barreto comprised 29 students, two of the seventh grade (age 12 and 14), 19 of the eighth grade (age 12-14) and 8 of ninth grade (age 14). No time limit was given for the completion of the two questionnaires.

### **2.4. Analysis**

Comparison of student's mean interest and knowledge before and after visiting the exhibition was compared by Student's t tests at a confidence level of 95%.

## **3. Results**

### **3.1. Before visiting the insect exhibition**

Before the visit to the exhibition the knowledge of boys and girls of each school about insects was similar. Most students of the three schools responded correctly to the questions on whether insects can live in water (64.2% to 85.1%), larvae are insects (44.8% to 74.6%) and insects are important in nature (85.7% to 97.3%). However, the majority of students of the three schools did not know how many legs insects have. They considered that the number of legs varied depending on the type of insect (61.8% to 100%). Only 2.6% of the students from Santa Teresinha and Salesian school responded correctly to this question, while all students of Francisco Barreto gave a wrong answer.

There were also differences between rural and urban school students, being those of

Francisco Barreto less interested. Boys and girls of this school liked insects less (42.8% boys vs 7.6% girls), have less interest in having an insect as a pet (35.7% boys vs 6.6% girls) and when they encounter an insect were less those that said that would observe them (64.2% boys vs 50% girls) comparatively to students of the other two schools. In addition, Francisco Barreto students have less scientific interests (fourth block of questions) than students of the other two schools. Regardless of the school, boys and girls were more interested on how dinosaurs lived and why they have disappeared (83.1% boys vs 70.3% girls) than in the five other scientific topics.

### 3.2. After the visit to the insect exhibition

The student interest and attitudes regarding insects increased after the visit to the exhibition. As a whole more students stated that liked more insects after the exhibition (after 59.89 % vs 53.07% before) than before (Fig. 1).

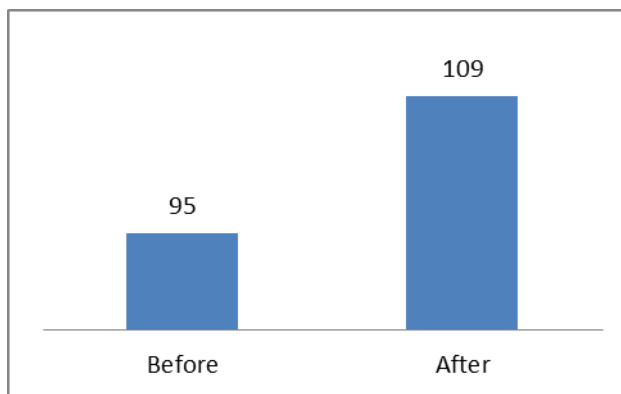
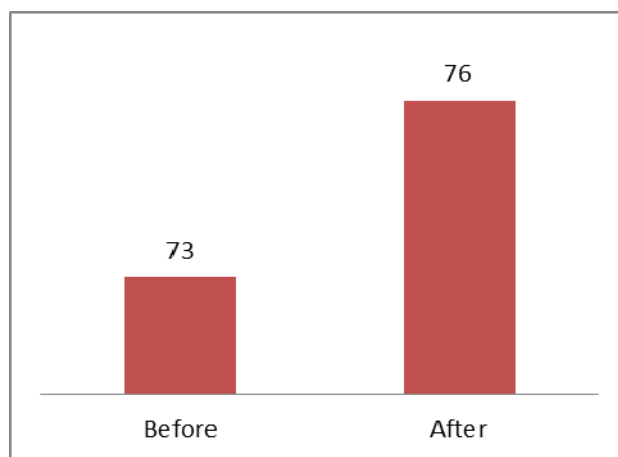

**Figure 1. Number of students that said to like very much insects before and after visiting the exhibition**

After the visit there were also a slightly increase in the percentage of students that said that would like to have an insect as a pet (41.4% before vs 41.9% after) (Fig. 2). The percentage of students that said after and before the exhibition that would not like an insect as a pet was similar.

There was a slight improvement in the reaction of students when they encounter an insect. The percentage of those that said that will observed them increase with the visit (69.2% before vs 72.3% after) while decrease the percentage of those that said that will kill them (7.2% before vs 6.6 % after), will ran away (8.2% before vs 8.9% after) and scare

them (14.5% before to 12.7% after) (Fig. 3).



**Figure 2. Number of students that said would like to have an insect as pet before and after visiting the exhibition**

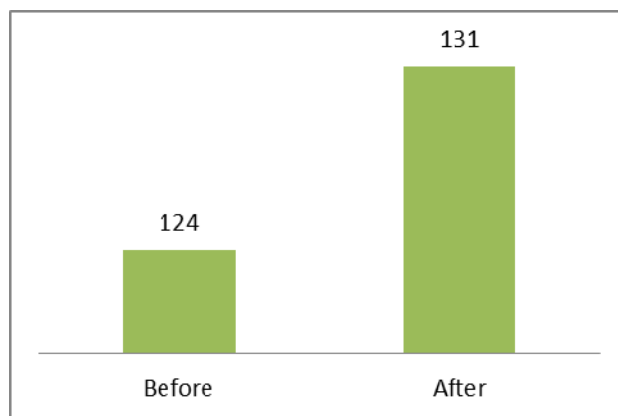

**Figure 3. Number of students that said that if they encounter an insect will observe it before and after visiting the exhibition**

Concerning knowledge, there was an increase in the level of the importance attributed to insects in nature with the visit (90.8% before vs 92% after) and also more students responded that larvae are insects (68.1% before vs 78.3% after). However, the visit did not allow the acquisition of more specific knowledge about insects. For example less students said that insects have six legs (2.2% before vs 1.6 % after) and less number of students said that there are insects that live in the water (73.2% before vs 60.3 % after) which suggest that the pedagogical content had not been worked before or during the visit with the teacher.

The visits to the exhibition awake also the interest of students for other areas of science. After the exhibition students were more attracted to stars, planets and universe (from



61.2% to 69.8%), the origin and evolution of life in Earth (from 56.3 to 64%); how insects live (from 58.8% to 71.1%), the animals from different parts of the world (from 63.5% to 68.5%), how human body is made and works (from 59.6% to 67.5%) and how dinosaurs live and why they disappear (from 76.5% to 81.9%). However, this increase was only significant for the origin and evolution of life in Earth ( $t=2.705$ ,  $df=16$ ,  $p=0.008$ ) and how insects live ( $t=-4.379$ ,  $df=165$ ,  $p=0.0$ ).

#### **4. Discussion**

Most people like small animals particular vertebrates such as birds, squirrels, dogs but dislike invertebrates, bats, rats and mice [13]. The results of this study suggest that most primary school children in Madeira have positive attitudes toward insects. They like insects and most students said that if they encounter an insect they would rather observe instead of kill it, scare it or run away. Contact with insects through the study visit influenced children's behavior towards insects, building positive attitudes towards animals. In this regard it has been suggested that teachers should encourage children to keep a diverse range of animals, particularly invertebrates, and that science activities should be more focused on rearing invertebrates and improving children's attitudes and knowledge [14]; [15].

Evertheless, the percentage of students that said that would like to have an insect as a pet after the visit to the exhibition increase only slightly. Likewise, as occur in other surveys [16], only few more students were those that would prefer to observe insects if they encounter them. It has been shown that when children interact with animals develop positive attitudes [17], [14]. It is unknown whether the students of this survey have such contacts with animals. More chances of contact animals/insects would be expected in children from rural residence areas as those Francisco Barreto School than children from the other two schools that live mainly in urban areas. Instead of this, children from rural areas not only were less interested on insects but also have less interest on other scientific areas. Because students from Francisco Barreto were older, their lack of interest may be related either to the area of residence and/or to age. Major differences in attitudes toward animals can occur among children according to age, sex,

ethnicity, and urban/rural residence [18], therefore the reasons for these differences cannot be ascertain.

The visit to the exhibition promoted not only an increase in positive behavior towards insects but also, an increase of interest for other areas of science as zoology, human biology and astronomy. The positive appreciation and increase interest on insects and science in general, did not correspond to an increase in the specific knowledge gained on insects, this was below expectations. Most children fail to enumerate the number of legs that insects have or that insects live in the water. In fact this knowledge decreased after the visit. This can in part be related to the fact that a few non-insects groups such as spiders and scorpions were exhibited together with insects in the exhibition. This, together with the title of the exhibition *Living Insects from around the World*, could explain in part why students fail to recognized the number of insect legs (6 insects vs 8 spiders/scorpions). It is generally believe that experiential learning activities and school field trips are effective strategies to create authentic learning opportunities for students regardless of the content area. However, experiential activities and field trips do not simply happen. Teachers need to understand that such activities require previous preparation of children and teachers, hands-on activities for children and follow-up actions to maximize the learning experience [10]. Teachers should prepare field trips in order to promote the interest and knowledge of their students. Children should also be allowed to interact with the organisms, observed them and discuss what they see [19] to acquire knowledge and avoid insect misconceptions [20]. Once teachers develop a successful field trip, they will enable students to grow interest in science, which may lead to better-quality learning and improved science literacy.

Science exhibitions increase visitors' knowledge and understanding of science but also can generate memorable learning experiences which can have a lasting impact on attitudes and behavior. Field trips offer a unique opportunity for students to create connections, which will help them to gain understanding and develop an enjoyment of learning. Farmer, Knapp, and Benton [21] suggested that one year after a well-designed field trip experience, many students

remembered what they had seen and heard, and displayed a newly developed prescience attitude. This long lasting effect was observed by the second author of this work, who took her 4 years old niece to the exhibition. At that at that time this little girl showed great interest and curiosity on the observation of the insects. Now that she is 12 years old still remembers many aspects of the visit and talks about it. Furthermore, she demonstrates high interest in science and nature in particular. Although science learning in the informal context may be often seem as haphazard and incoherent, it is believe to be long lasting because is internally rather than externally driven [22]. Thus, visits to exhibitions as well as other non-formal or informal learning activities can have a positive impact on children and adolescents' behavior in relation to nature and nature conservation.

## 5. Acknowledgments

We wish to thank Guida Mendes for her valuable help and to the schools, and students and teacher that participate in this study.

## 6. References

- [1] Leakey R, Lewis R. *The Sixth Extinction: Patterns of Life and the Future of Humankind*. Doubleday; New York; 1995.
- [2] Ceballos G, Ehrlich PR, Barnosky AD, García A, Pringle RM, Palmer TM. Accelerated modern human-induced species losses: Entering the sixth mass extinction. *Sci. Adv.* 2015; 1:e1400253.
- [3] Kellert SR. Attitudes toward animals: Age-related development among children. *Journal of Environmental Education* 1985; 16(3): 29–39.
- [4] Eagly AH, Chaiken S. *The psychology of attitudes* 1993; Orlando: Harcourt Brace Jovanovich.
- [5] Pooley JA. Environmental Education and attitudes: Emotions and Beliefs are what is needed. *Environment and Behavior* 2000; 32(5): 711–723.
- [6] Zhuang SJ. Action research of elementary school students' learning camp insects. A Master's thesis of National Taipei University of Education; 2002.
- [7] Orion N, Hofstein A. Factors that influence learning during a scientific field trip in a natural environment. *Journal of Research in Science Teaching* 1994; 31(10): 1097–1119.
- [8] Tunnicliffe SD, Lucas AM, Osborne J. School visits to zoos and museums: A missed educational opportunity? *International Journal of Science Education* 1997; 19(9): 1039–1056.
- [9] Eshach H. Bringing in-school and out of school learning: Formal, non-formal and informal education. *Journal of Science Education and Technology* 2007; 16(2): 171-190.
- [10] Behrendt M, Franklin T. A review of research on school field trips and their value in education. *International Journal of Environmental and Science Education*; 2014; 9(3): 235.245. doi: 10.12973/ijese.2014.213a.
- [11] Tal T, Morgan O. Reflective practice as a means for preparing to teach outdoors in an ecological garden. *Journal of Science Teacher Education* 2009; 20(3): 245-262.
- [12] Scarce R. Field trips as short term experiential education. *Teaching Sociology* 1997; 25: 219-226.
- [13] Bjerke T, Østdahl T. Animal-related attitudes and activities in an urban population. *Anthrozoös* 2004; 17(2): 109–129.
- [14] Prokop P, Prokop M, Tunnicliffe SD. Effects of keeping animals as pets on children's concepts of vertebrates and invertebrates. *International Journal of Science Education* 2008; 30(4): 431–449.
- [15] Prokop P, Prokop M, Tunnicliffe SD, Diran C. Children's ideas of animals' internal structures. *Journal of Biological Education* 2007; 41(2): 62–67.
- [16] Bjerke T, Østdahl T, Kleiven J. Attitudes and activities related to urban wildlife: Pet owners and non-owners. *Anthrozoös* 2003; 16(3): 252–262.
- [17] Bjerke T, Kaltenborn BP, Odegardstuen TS. Animal-related activities and appreciation of animals among children and adolescents. *Anthrozoös* 2001; 14, (2):

86-94.

- [18] Keller SR. Values and perceptions of invertebrates. *Conservation Biology* 1993; 7(4): 845–855.
- [19] Patrick P, Tunnicliffe SD. ‘What plants and animals do early childhood and primary students’ name? Where do they see them?’ *J. Sci. Educ. Technol.* 2011; 20: 630–642.
- [20] Bell B, Barker M. Towards a scientific concept of ‘animal’. *J. Biol. Education*, 1982; 16: 197-200.
- [21] Farmer J, Knapp D, Benton G. An elementary school environmental education field trip: long-term effect on ecological and environmental knowledge and attitude development. *Journal of Environmental Education* 2007; 38(3): 33-42.
- [22] Stocklmayer SM, Rennie LJ, Gilbert JK. The roles of the formal and informal sectors in the provision of effective science education. *Studies in Science Education* 2010; 46:1-44.
- 
-

## Color, Light and Matter - the Simplicity of Metal Ion Complexes

I Boal-Palheiros  
University of Aveiro, Portugal  
isabel.boal@ua.pt

**Abstract.** Why is blood from humans red and blood from snails and crabs blue? And why are rubis red and emeralds green? Those are questions meant to challenge students to investigate the interaction of light and matter. In fact, the chemistry of color of transition metal ions is responsible for the color of many substances and is amenable to be easily understood by secondary school students. Moreover, transition metal ions are the center of coordination compounds that are relevant in many fields and play a decisive role in the Chemistry of Life - even if present in minute amounts. In this activity, targeted for secondary students as well as freshmen of Biology and Chemistry related degrees, the interaction of light and matter is investigated, and an explanation of color is obtained.

**Keywords.** color, coordination compounds, hands-on learning, high school students, inquiry based research, laboratory work, light, metal ions, radiation

### 1. Introduction

In the University of Aveiro, as in many Portuguese universities, secondary students come to the University to participate in either dedicated activities or included in research projects. A most popular program is „Semana da Ciência & Tecnologia“, where by students come to the University to engage in diverse scientific activities (conferences, lab experiments, field work).

The experimental activity now reported was part of this program of the latest edition, in 2014. This laboratory activity *Color, Light and Matter - the Simplicity of Metal Ion Complexes* [1] relates concepts in chemistry that secondary students are familiar with (atomic orbitals, energy levels, electronic configuration, Periodic Table) with Inorganic Chemistry ones, in the field of coordination chemistry (coordinate bond, donor atom and ligand). They become acquainted with complexes and their major importance for Life and extensive day by day use. In fact, coordination compounds have a

central role from household detergents to oxygen carrier proteins. Moreover, they familiarize also with relationships energy/wavelength of radiation and color and also with UV/Vis spectroscopy. And most importantly, students learn fundamental issues through an inquiry based, hands-on activity in an informal environment.

The model for Chemistry education consists of three components: macro, sub-micro and symbolic representations [2] and has been used by various researchers [3]. The model emphasizes the relation between macroscopic chemical and physical properties of substances, and structures on micro level, that is atoms and molecules. This relation is a central core in Chemistry, and chemists are expected to relate these two worlds and predict chemical activity. In the referred model [3] the macro and sub-micro levels seem to refer to observable vs. unobservable dimensions and this may be a difficult task for students. Instead, the focus should be on the concept pair properties – structures [4]. Furthermore, intermediate stages or levels in the learning process are necessary [4] to guide students from observable phenomena (substance properties) to explanatory models (structures).

The main goal of this activity is precisely to guide students from observable phenomena – the color of different substances to explanatory models – structure of matter. The relation between a macroscopic physical property of substances - color, and structures on micro level is emphasized. The reactivity of substances is only marginally addressed, when ammonia displaces water in the coordination sphere of the central metal ion.

Throughout the experimental activity, learners engage in scientifically oriented questions that are meant to be answered and explained by evidence obtained from experimental data. An inquiry approach using some guidance was used to help students focusing in the novel concepts and gather the explanations of the observed facts. The context of this activity and time limitations in particular, preclude the use of more open inquiry strategies. However, in order to foster cognitive development and scientific reasoning, a few problems and questions are posed for students to think later.

## 2. Color

Color has fascinated human kind ever since it may be ascertained: from Lascaux caves to contemporary art - as the huge amounts of money paid for Picasso, Klimt or Van Gogh paintings evidence. Every child is enchanted with rainbow colors and this passion for color remains throughout life. This enthusiasm and attraction can be evoked and addressed to develop the children's curiosity and will to understand the natural world. In the case of the present work, that means to study the structure and behavior of the physical and natural world through observation and experiment - make science. This laboratorial activity was proposed for secondary students aiming at helping them to learn how to make science using an appealing theme. At the same time, it also helps them to understand the principles of color through a set of experiments. In these experiments they use their previous knowledge (atomistic nature of matter, atomic orbitals, quantification of energy, radiation) and go one step further into relating electronic transitions and light.

Transition metals are in the center of modern Periodic Table, the d-block. Main group elements contain both metals and non-metals; all transition elements are metals. Apart from mercury, they are solid and conduct electricity and heat well. Most main group ionic solids are colorless (or white); in contrast, many transition metal compounds have strikingly beautiful colors! When 1% of  $\text{Al}^{3+}$  is replaced by  $\text{Cr}^{3+}$ , in colorless corundum or beryl, the beautiful red rubi or the green emerald, respectively, are obtained.

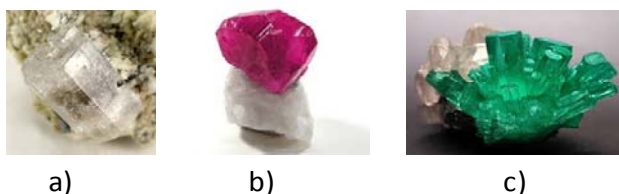

**Figure 1. Colorless minerals gain color when 1  $\text{Al}^{3+}$  in 100 is replaced by  $\text{Cr}^{3+}$ : a) corundum, b) rubi c) emerald**

The properties of elements and their compounds arise from the electrons associated with that element [5, 6]. Main group metal ions have a filled outer level (noble gas configuration). When electrons are promoted into higher energy levels, these are so high that

the ion absorbs light that is not in the visible range. The valence electrons for transition metals are the  $ns^2$  electron and also the  $(n-1)d$  electrons. The transition metal ions bear a positive charge and behave as Lewis acids, accepting negative charge. The negative charge may come from ions such as chloride ( $\text{Cl}^-$ ) or oxalate ( $\text{C}_2\text{O}_4^{2-}$ ), but also from a pair of lone electrons of an atom constituting a neutral molecule such as water ( $\text{H}_2\text{O}$ ), ammonia ( $\text{NH}_3$ ) or ethylenediamine ( $\text{C}_2\text{H}_4(\text{NH}_2)_2$ ). These bonds are named coordinate bonds, since both electrons belong to the same atom, the donor atom, and the respective ion or molecule is named ligand. The new entity formed is a complex ion or a coordination compound and embodies a most distinctive aspect of the transition metal ions chemistry. Many transition metal complexes bind to six donor atoms and have an octahedral geometry [5, 6]. In Fig. 2, the complex formed by a central metal ion and six water molecules is depicted.

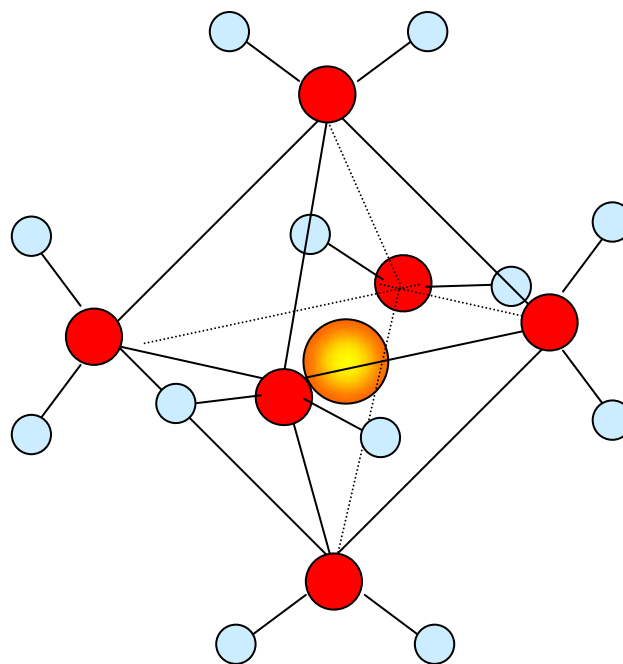

**Figure 2. Octahedral distribution of six water molecules around a central metal ion**

The five  $d$  orbitals of an isolated transition metal ion have the same energy, are degenerate, but in the presence of 6 donor atoms in an octahedral geometry, the energy of  $d$  electrons is split into two levels, since the orbitals are not equally affected: those superimposed along the orthogonal axes ( $d_z^2$  and  $d_{x^2-y^2}$ ) will have higher energy than  $d_{xy}$ ,  $d_{xz}$  and  $d_{yz}$  orbitals, because the latter lie between the axes and are farther from the

ligands and, therefore, experience less repulsion.

The energy gap between those levels depends on the central metal ion valence electrons and on the donor atoms, but corresponds usually to visible light. Electrons in a partially filled *d* orbital can absorb visible light and move to slightly higher *d* orbital energy levels, imparting color to those substances. Fig. 3 illustrates a scheme of *d-d* transition for Cr(III) in an octahedral field.

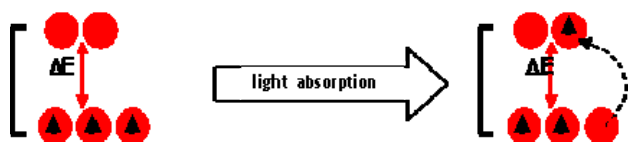

Figure 3. Scheme of a *d-d* transition for Cr(III) in an octahedral field

Another aspect students become also familiar with is that the number of donor atoms per ligand can be diverse. Some are single donor atom ligands ( $\text{H}_2\text{O}$ ,  $\text{NH}_3$ ,  $\text{Cl}^-$ ) but other ligands, such as oxalate or ethylenediamine, have two (bidentate), and some may have more (EDTA has 6 donor atoms), forming a *quelate*.

A very special and important class of ligands are aminoacids. These molecules form proteins and comprise the second-largest component (water is the largest) of human cells and muscles. Outside proteins, they perform crucial roles in processes such as biosynthesis and neurotransmitter transport. They may bind to metal ions and have a role in the transport of oxygen in the blood.

The red color of blood of vertebrates is a consequence of the complex of iron with heme [7], in hemoglobin, as depicted in Fig. 4.

In hemoglobin, and apart from the heme iron is linked to a histidine residue of globuline and water or oxygen, and has an octahedral geometry ( Fig. 5).

However, iron is not the only metal ion with a central role in respiration and red is not the color of all blood. Horseshoe crabs, octopus

and lobsters, for instance, have blue blood [7]. In these animals, the molecule that transports oxygen is hemocyanin, that contains copper ions (Fig. 6.a). When deoxygenated, the blood is colorless, but in the presence of oxygen, the cupric ions impart blood a sapphire blue color. The blue blood of horseshoe crabs can be seen in Fig.6.b when it is harvested from them to be used in tests to ensure medicals are not contaminated [7].

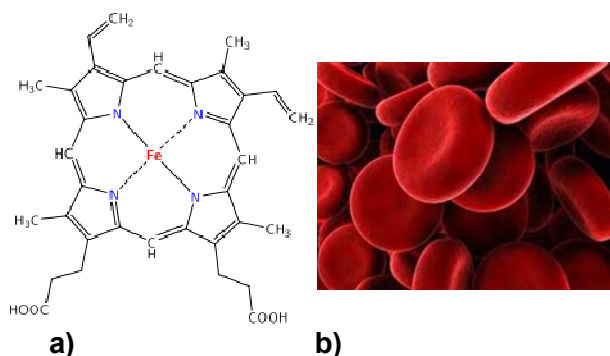

Figure 4. Iron bound to N-donor atoms in heme (a) imparts red color to blood hemoglobin in red cells (b) [7]

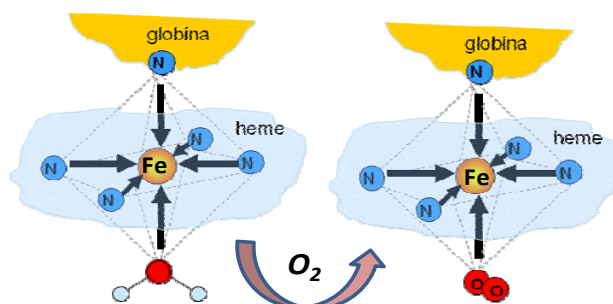

Figure 5. Iron in heme bound to an histidine residue of globuline and a molecule of water/ oxygen, octahedral field

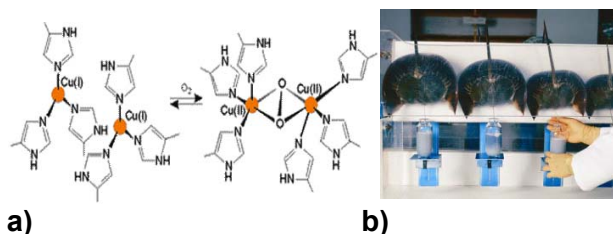

Figure 6. Hemocyanin where copper binds oxygen (a) that imparts to blood of horseshoe crabs a blue sapphire color (b) [7]

### 3. Hands-on

The experimental activity here reported is meant for 10<sup>th</sup> to 12<sup>th</sup> grade students since they are familiar with chemistry fundamentals and in



particular with electronic configuration and energy levels of elements. It was planned to be carried out with little help from the instructor, apart from the spectra acquisition. A period of 3 hours (maximum) should be enough to carry out the experimental work (1-2 hours) and the initial and the final discussions (1 h).

To help them through this activity, the young students are given a booklet, divided in 5 sections: 1) an introductory text about relevant contents (Periodic Table, elements, electronic configuration, radiation wavelength and energy); 2) the experimental protocol detailing what to do and what to write down, and also posing questions to help the students to observe and reflect; 3) deeper insight on coordination chemistry and biological ligands as well as some interesting issues around the theme; 4) a few practical problems closely related with the activity for students to solve and self-evaluate; 5) a glossary with around forty keywords (that are used and highlighted along the text) in alphabetical order, so that the related information may be retrieved easily.

To begin with, a discussion is made about Periodic Table, transition metals and respective electronic configurations. These are concepts secondary students are familiar with and a vivid participation is generally witnessed. Then, a visualization of *d* orbitals representation is shown (pictures, 3-dimension models), so that the students can understand why some *d* orbitals of the central metal ion are more affected than others when ligands bind to it. Once the splitting of the *d* orbitals is acknowledged, the relation between the energy gap and light wavelength of absorption may be easily understood by them.

The participants start the experimental work by observing several compounds (sulphates mostly) of metal ions from *s* and *d* blocks and dividing them into colored/uncolored groups. For this purpose, sodium, potassium, magnesium, calcium and transition metal ions of the 3rd period of the Periodic Table only were used (chromium, iron, cobalt, nickel, copper and zinc). Next, they prepare aqueous solutions of the colored ones; except for zinc, different colors may be seen for the transition metal ions solutions (Fig. 7).

When light is shed upon the solution, it absorbs mainly in a particular region of the visible light spectrum (maxima), and the

remainder radiation is transmitted. The wavelength of absorbed color is related with the color seen - complementary color.

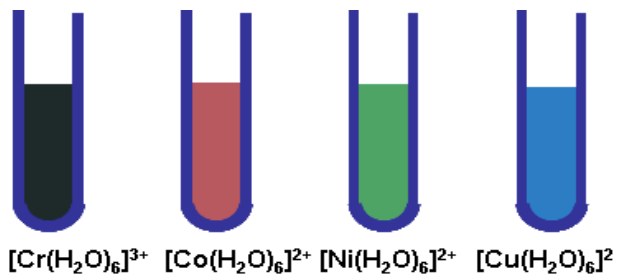

Figure 7. Aqueous solutions of several transition metal ions

The UV/vis spectra of each colored solution is recorded. From the spectra maxima of the aqueous solution of each ion, the respective absorbed energy can be computed. For the sake of simplicity, when several maxima are obtained, the highest wavelength (least energetic) maxima is considered to determine the energy gap. When the same ligand ( $\text{H}_2\text{O}$ ) is combined with different metal ions, a relation between electron configuration, *d*-orbitals energy gap,  $\Delta E_{\text{oc}}$ , absorbed radiation and color can be inferred.

The effect of the ligand is then investigated. Concentrated ammonia is added to aqueous solutions of  $[\text{M}(\text{H}_2\text{O})_6]^{+2}$ . As water is consecutively replaced by ammonia, a different color evolves. The visual effect is complemented by UV/Vis absorption measurement of the solutions. For each metal ion, the energy gap for  $[\text{M}(\text{NH}_3)_6]^{+2}$  is compared with the gap previously obtained for  $[\text{M}(\text{H}_2\text{O})_6]^{+2}$ ; the effect of having oxygen or nitrogen as donor atoms may be evaluated. To further investigate the influence of donor atom in the *d*-orbital energy splitting and in color, a series of complexes of the same central ion ( $\text{Cr}^{3+}$ ) and different ligands (oxalate, ethylenediamine) was studied. Fig. 8 presents the spectra of aqueous solutions of Cr(III) coordinated to ethylenediamine (A) and oxalate (B).

The wavelength maxima clearly shift to higher values – corresponding to lower energy gap, when the nitrogen donor atoms of ethylenediamine are replaced by the oxygen atoms of oxalate. Similar results are obtained for other metal ions. A relation can be ascertained between donor atoms and gap energy and an order can be established for the

studied ligands. The students compare the experimental energy order with the one expected from the *spectrochemical series* [5, 6] that is presented in the booklet.

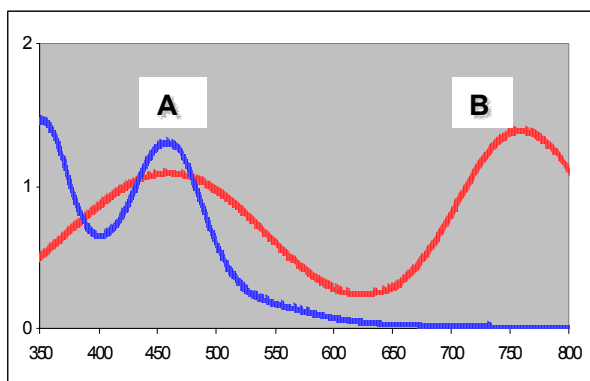

**Figure 8. Spectra of aqueous solutions of Cr(III) coordinated to ethylenediamine (A, blue) and oxalate (B, red)**

Upon completing the experimental activities, the students answer a self-evaluation quiz with a few questions closely related to the experiments made. Other questions are posed along the booklet for the students to ponder, reflect and answer later.

The participants are also invited to answer a couple of questions about the activity.

#### 4. Results and concluding remarks

In this edition of the initiative “Semana da Ciência & Tecnologia”, fourteen 12 th graders enrolled in the activity; 12 originate in the same class and were accompanied by their Chemistry teacher, and two come from different classes. They were all female students.

The participants were briefly informed on the goals and procedures of the activity and were given a booklet each to read the introductory section. Then a discussion about key subjects involved; the students were very keen to demonstrate how well they were prepared and they debated enthusiastically.

Then, and before any experimental activity, they were given lab coats, gloves and safety goggles and were divided in 4 teams. These students were already familiar with good laboratory practices in technical issues and only a few remarks about safety details in the lab were made. The 12 th graders followed very carefully the experimental procedure and wrote down all observations and necessary data. Two

spectrophotometers were used to obtain the spectra of the solutions and two instructors assisted the students in this task. Occasionally, students put some questions to instructors, but they generally worked autonomously.

When they finished the practical work, a discussion within each group took place, and after that they answered (anonymously) the quiz presented in Table 1.

1 The color observed in the coordination compound of transition metal ions originates from electronic transitions from

- a)  $s$  orbitals to  $p$  orbitals
- b)  $p$  orbitals to  $d$  orbitals
- c)  $p$  orbitals to  $d$  orbitals

2 The color observed in the coordination compound of transition metal ions depends on

- a) central metal ion
- b) ligands and donor atoms
- c) both

3 According to their structure it is expected that the following complexes have color or not

- a)  $[\text{Fe}(\text{CN})_6]^{4-}$
- b)  $[\text{Mg}(\text{H}_2\text{O})_6]^{2+}$
- c)  $[\text{Cu}(\text{NH}_3)_4]^{2+}$
- d)  $[\text{Na}(\text{H}_2\text{O})_6]^{2+}$
- e)  $[\text{Mn}(\text{Cl})_6]^{4-}$
- f)  $[\text{Cu}(\text{NH}_3)_4]^{2+}$

4 Comment on the following statement, namely if you consider it true or false and why

*“For a given central metal ion, the energy of the  $d-d$  transition is the same, regardless of the ligand it is bound to”.*

**Table1. Questions of the quiz answered by the students at the end of the lab work**

The correct answers to questions 1, 2 and 3 were 100%, 83 % and 75 %, respectively. The answers to question 4 were 83 % correct and most were very well justified.

The students considered the activity most interesting (83 %) and interesting (17 %) and useful (33 %) or very useful (50 %). They enjoyed it (58 %) or enjoyed a lot (42 %). The number of students was not very large, but their

opinions are still meaningful. Identical results had been achieved in a similar activity where chromium complexes with amino acids were investigated [8]. However, a serious drawback prevented that activity from being broadly implemented - the (non) availability of chromium complexes. These complexes are not for sell and some are not easily synthesized either. The novel activity now proposed has the same goals and methodologies but uses reagents that are common in any chemistry laboratory.

The students' participation in this laboratory work around color demonstrates that they were able to perform an inquiry based activity with a considerable degree of autonomy. They engaged in scientifically oriented questions and were able to answer and explain the evidences obtained from experimental data. With this lab activity the students succeeded in linking observable phenomena – the color of different substances to explanatory models – the structure of matter. The answers provided by students and their discussions along the activity evidence also deep conceptual learning

Last but not least, the students much enjoyed having this colorful hands-on activity.

*Fiat lux!*

## 5. Acknowledgments

The author thanks Dr. Teresa Caldeira for help and support during the laboratorial work.

## 6. References

- [1] Boal-Palheiros I. Cor, luz e matéria - a simplicidade dos complexos. Semana da Ciência & Tecnologia; Universidade de Aveiro; 2014.
  - [2] Johnstone AH. *Macro- and micro-chemistry*, School Science Review; 1982, 64, 377-379.
  - [3] Gilbert JK, Treagust DF. Introduction: Macro, submicro and symbolic representations and the relationship between them: Key models in chemical education In Gilbert JK & Treagust DF (Eds.); Multiple representations in chemical education. Dordrecht: Springer; 2009.
  - [4] Goedhart M, van Duin Y. Teaching Structural Formulas In Chemistry, Proceedings of NARST Conference. Boston; March 29, 1999.
  - [5] Lawrance GA. Introduction to Coordination Chemistry; Wiley Ed.; 2009.
  - [6] Cavaleiro AMV. Química Inorgânica Básica. 3<sup>a</sup> ed.; Universidade de Aveiro; 2004.
  - [7] Lutz D. The many colors of blood. Chem. Matters; 2010, 20 (1), 5-7.
  - [8] Boal-Palheiros I, Santos TM. A cor e os compostos de crómio(III) com aminoácidos-uma janela inorgânica para a Química da Vida. Semana da Ciência & Tecnologia; Universidade de Aveiro; 2010.
- 
-

## Control of Carnivore Overpopulation (Egyptian Mongoose and Red Fox): Study Case in the Council of Azambuja (Portugal)

M Teodósio, S Seixas  
Universidade Aberta, Lisboa, Portugal  
marisaact@gmail.com, sonia.seixas@uab.pt

**Abstract.** The presence of predators in a habitat is considered a stabilizing force in the population of herbivores, contributing to the balance of the ecosystem. However, the predator's overpopulation causes a drastic reduction of primary consumers, exceeding the capacity of the ecosystem and endangering the entire food chain. To solve that situation, density control actions are being implemented by man, for balance maintenance purposes or to prevent damages. Often, in the council of Azambuja, there are carried out these actions, by Hunting Associations to control the carnivore population in forest areas, in particular the egyptian mongoose (*Herpestes ichneumon*) and the red fox (*Vulpes vulpes*), for their allegedly effect on the lagomorphs population decline.

The objective of this study was to describe the capture process end-to-end: how the authorization is required, how is it done in the field, how the fiscalization is made and the results on the biodiversity.

The methodology used was the record of the process, interview of the people responsible in field for these actions, and consultation with the national authorities involved.

It was verified that the national services which controls these actions (National Institute for Nature Conservation and Forestry) and responsible for the evaluation of the licenses requests, issued these ones to a local hunting association, without any previous study of those two species population's densities or maximum carrying capacity of the environment for them. There's no effective supervision of the implementation of this action in the field. It was also clear that hunters use these actions, not to guarantee the ecosystem balance, but to eliminate predators in order to increase the lagomorph's population for the hunting season. So a process that first established the ecosystem's balance can and may do exactly

the opposite.

**Keywords.** *Vulpes vulpes*, *Herpestes ichneumon*, overpopulation control, ecosystem balance

### 1. Introduction

Biodiversity is characterized by the connections between the living beings on a community and for their genetic richness. One factor that promotes biodiversity is the balance between primary and secondary consumers and their population height on the food web. Therefore, the increase or decrease on the species effective, affects all the others which whom they have direct or indirect relations. In Portugal, the wild rabbit (*Oryctolagus cuniculus algirus*) it's an extremely important lagomorph for the habitat maintenance, being the main prey for numerous carnivore species, like the iberian lynx (*Lynx pardinus*) and the spanish imperial eagle (*Aquila adalberti*) [1], and for that, it is considered a key specie.

The egyptian mongoose (*Herpestes ichneumon*) and the red fox (*Vulpes vulpes*) are two of the most common carnivores in Azambuja council and, allegedly, the ones that induce the wild rabbit population decrease, together with viral diseases and intensive agriculture [2, 8]. For this reason and to prevent damages, are carried out actions to control the carnivore population numbers, on hunting, agriculture and forest areas. So, the purpose of this study was to describe the capture process end-to-end: how the authorization is required, how is it done in the field, how the fiscalization is made and the results on the biodiversity. For that, the national's authorities responsible for the analysis, authorisation and surveillance were consulted and a local hunting association, that was carrying population control actions, was interviewed and accompanied in the field.

### 2. The species

The red fox is one of the most common carnivores in Portugal. Belongs to the Canidae family and it's characterised by a reddish or greyish fur on the back, white back and the tail is long and with tufts. Is a night specie and habits mostly forest, scrubland and agriculture areas [3] (Fig. 1).

The egyptian mongoose is also a carnivore and the only mongoose specie in Europe and



exclusive for the Iberian Peninsula. Belongs to the Herpestidae family and it's characterised by a uniform, mingled, dark fur, a pointy and large tail, paws proportionally shorter to the body, nails not retracted and used for digging [4] (Fig. 2).



**Figure 1- Red Fox (Source: Naturdata © Fernando Romão)**

### 3. The study area

The Azambuja council is the most eastern council in the Lisbon district, in Portugal, and it is the most densely populated along the rail/road lines (Fig. 3).



**Figure 2 - Egyptian mongoose (Source: <http://fotos.sapo.pt/greenbit/fotos/?uid=tdZon46vH4SBNkTZjFqC>)**

The landscape is dominated by olive and fruit trees, vineyards, and limited in the north by *Pinus Pinaster*, *Pinus pinea*, *Eucalyptus globules*, *Quercus suber* and *Quercus faginea*, in the south by Ribatejo marshlands and in the west by the Montejunto Mountain range.

The river in area is the biggest river in Portugal, the Tagus River.

In geological terms, prevails the sedimentary rocks, sandstone, conglomerates and clay. These conditions provide a preferential habitat for the species in study: low population density/human pressure, sand terrains that enable them to dig burrows and access to water and food. Supporting this statement, there are twenty three hunting areas in the council.



**Figure 3- Azambuja's council environment map. Above the council is highlighted in red Source LNEG, National Laboratory on Energy and Geology. The below map is a satellite photo (Google Maps)**

### 4. Applicable Legislation

Red fox and egypton mongoose are considered small game hunting and their capture is allowed on the hunting season, from October to February.

If necessary, to prevent or minimize damages on flora, fauna, fishing, forest, agriculture, livestock, health protection and/or public security, their capture is possible (predator population control), provided they are authorized by the Institute for the Conservation of Nature and Forests (ICNF) [5]. The enforcement and surveillance are

responsibilities of the Nature and Environment Protection Service (SEPNA) from the National Republican Guard (GNR).

## 5. Results

The process starts with a request from the hunting association to ICNF in which is requested a predation population control, specified to the red fox and egyptian mongoose, the damage or endangered area and the means that are going to be used during the activity. The most frequent one is by the use of live animal cage trap (figure 4). The bait used in cages is a dead rabbit or a piece of pork rind (figure 5).

After an information request, ICNF informed that the criteria are:

- i. the substantiation of the request according the law;
- ii. adequacy of the request in relation to the area;
- iii. reports with results of prior actions, in which the association has to quantify the captured animals and cages involved.

On the request, the hunt association propose to place a number of cage traps (the limit allowed is ten cage traps). If the request doesn't mention a proposal, ICNF only allows the placement of six cage traps.

This authorization is sent to SEPNA who is responsible for ensure that:

- (i) the numbers of cage traps don't exceed the one given in the authorization,
- (ii) that only the species authorized are the ones captured and killed,
- (iii) That the cages are placed only in authorized area.

There is no reference on the request or in the authorization to a limit number of captured animals. After consulting ICNF, it was referred that due to the fact that there was no studies that evaluate or provide knowledge about these species population density on a specific region or hunting area, the justification is an applicant's responsibility (the hunt association).

We've contacted SEPNA and after received information request, notice that in the past years, the authorizations are standardized and ad-hoc, that doesn't exists a compliance record of the amount of captured animals or an impact

study for this activity. It has also indicated that the elevated number of hunting areas on the Azambuja council and on the surrounding ones, allied to the fact that the hunters are familiarized with the terrain and a small team to check all ones, translates in a deficient surveillance.



Figure 4- Live animal cage trap (photo captured in field)

In fact, for the attended association (hunt association where we've donned the work), was only allowed the placement of 5 cages and during the record in field, the number of cage traps seen exceeded by far this number. In fact we've counted 17 cages.

It is important to note that the main activity of hunting associations is to hunt wild rabbits, in the study area. If rabbits do not exist or the population is reduced, no one hunts and so, the dues aren't going to get paid by the members, putting in jeopardy the association's existence.

## 7. Discussion

In Portugal, the economic interests still remain as one of the greatest obstacles to environment protection and existing biodiversity maintenance. Given that Azambuja council holds intense cinegetic activity, and also the fact that these two species are the most commons targets of overpopulation control, understanding the impact of these actions, along the food chain and on local biodiversity, became the purpose of this work.

The overpopulation control action, itself, is a solution if a species number gets so big, that causes habitat unbalance. And in fact, in a community where predating is intensive, a negative pressure under the food web, is



expected. In this case, the prey is the wild rabbit, which could mean significant changes on the community structure, given the fact that key species have the ability to determine expressive variations on the species abundance on their habitat or even their extinction.



**Figure 5 – Baits used in cages. (photos captured in field)**

Rabbit population have declined due for instance to diseases and land use changes (Viñuela and Villafuerte 2004 in Beja *et al.*, 2009) [8]. In fact several diseases were discover in Portugal such as *Mycobacterium bovis* Infection in Red Foxes (*Vulpes vulpes*) with cerebral involvement (Matos *et al.*, 2014) [9] and *Mycobacterium avium* subsp. *paratuberculosis* in red fox and Egyptian mongoose (Matos *et al.*, 2014) [10]. Cardoso *et al.* (2014) [11] also found *Hepatozoon canis*, a protozoan tick-borne pathogen of dogs and wild canids, in ref fox in Portugal.

The most used method for the overpopulation control is the cage trap. There are other methods but they are most suitable

for areas where there are focused points, like agriculture or domestic animal damage: the area delimitation in not a solution, given their size and cost, and wouldn't give practical results because only prevents the carnivore's approach; the burrows fumigations to kill the cubs implies the knowledge of their location and, again, given the area size it isn't doable and, the use of venom isn't a selective method.

Either way, the assumption for these actions, is that the number of fox's and egyption mongoose is so high, that preventive or correction actions are needed. What has been observed and confirmed in the field and after the interviews, is that there's absolutely no data that testify/proves that situation, and we are watching an indiscriminate slaughter of these species, awarded by the agency that should protect them.

It would be expected that the government agency responsible for forest and nature protections, and plus with conservationists purposes, permitted these actions only as a last measure and only in possession with unquestionable data that proves an existing or soon to be agriculture and/or biodiversity impact, but in fact they direct the responsibility to the hunting associations. If the purpose of these actions is to reduce carnivore density, then the number of animals whose death is authorized should be the primary indicator on it, to establish the limit number on which the balance is restored between predators and system capacity. By not doing this, the authorities are tacitly approving the unlimited slaughter of these species as it is only referred the number of cages to be used and the period in this action can be occurred. As a single point of reference, prairie dogs that where assumed as a plague, are now endangered and systematic population control actions, are pointed as a main cause for that [6].

On the other hand, there is no prove that the rabbits population decrease is a result of an intense predating from the red fox and egyption mongoose, just because they're not the only prey of this animals and the mortality provoke by viral diseases is considerable.

Kirkwood *et al.* (2014) [7] mentioned that "both predator and prey populations should be monitored concurrently because the relationship between predator abundance and impact on prey species is not necessarily

density dependent”.

Lozano *et al.* (2013) [12] concluded that predator control can play a role in altering the carnivore communities; red fox numbers can increase due to control and predator control programs should evaluate the potential of unintended effects on ecosystems.

Given the above, mitigate and preventive measures are needed. Habitat surveys and characterization, regional planning, species limiting factors and annual population species census, are extremely important. The only existing studies about these species considered only geographic distribution and these works are dependent of hunting associations, who supply the data. Carrying descriptive and, most important, exempted works that provide trustful and critical information to the decision makers, and mostly engage awareness within society to these actions, is critical.

Barrull *et al.* (2011) [13] mentioned that traditional way to deal with hunting interests is often focused on predator control. A study done by Beja *et al.* (2009) [8] showed much higher abundances of small game species in game estates than elsewhere.

As a result, overpopulation control actions and, until preventive measures as the suggested above are taken, should only be used as a last resort, constituting the exceptional action in accordance with the law.

## 8. References

- [1] Pires JPL (2001). Ecologia Alimentar da Raposa [*Vulpes vulpes* (Linnaeus 1758)] no Parque Natural da Serra da Estrela. Tese de Mestrado em Ecologia Aplicada. Faculdade de Ciências - Universidade do Porto, Porto. 89 pp.
- [2] Pinheiro P. Desafios à conservação do Coelho-bravo: a Mixomitose e a Doença Hemorrágica Viral. Iberlinx. Available in: [http://www.iberlinx.com/index.php?option=com\\_content&view=article&id=53](http://www.iberlinx.com/index.php?option=com_content&view=article&id=53) [on July, 7<sup>th</sup> of 2014]
- [3] *Vulpes vulpes* – Naturdata Biodiversidade Online. Available in: <http://naturdata.com/Vulpes-vulpes-6692.htm> [on July, 2<sup>th</sup> of 2014]
- [4] Sacarrabos (*Herpestes ichneumon*) - Portal Santo Humberto. Available in: [http://www.santohuberto.com/sh\\_conteudo.asp?id=1184](http://www.santohuberto.com/sh_conteudo.asp?id=1184) [on July, 7<sup>th</sup> of 2014]
- [5] Lei de Bases Gerais da Caça, nº173/99 de 21 de Setembro. Diário da República: 1<sup>a</sup> série, No 221 (1999). Revisto pelo Decreto-Lei nº 159/2008 de 8 de Agosto. Diário da República: 1<sup>a</sup> série No 153 (1998). Revisto pelo Decreto-Lei nº 2/2001 de 6 de Janeiro. Diário da República: 1<sup>a</sup> série No 4 (2011). Available at [www.dre.pt](http://www.dre.pt).
- [6] Lomolino MV & Smith G. (2001), Dynamic biogeography of Prairie Dogs (*Cynomys ludovicianus*) towns near the edge of their range, *Journal of Mammology*, 82 (4): 937-945.
- [7] Kirkwood R, Sutherland D, Murphy S and Dann P. (2014). Lessons from long-term predator control: a case study with the red fox. *Wildlife Research* 41(3) 222-232 <http://dx.doi.org/10.1071/WR13196>.
- [8] Beja P, Gordinho L, Reino L, Loureiro F, Santos-Reis M, Borralho R. (2009) Predator abundance in relation to small game management in southern Portugal: conservation implications. *Eur J Wildl Res* 55:227–238. doi:10.1007/s10344-008-0236-1.
- [9] Matos AC, Figueira L, Martins MH, Matos M, Morais M, Dias AP, Pinto ML, Coelho AC. Disseminated *Mycobacterium bovis* Infection in Red Foxes (*Vulpes vulpes*) with Cerebral Involvement Found in Portugal. *Vector-Borne and Zoonotic Diseases*. July 2014, 14(7):531-533. doi:10.1089/vbz.2013.1500.
- [10] Matos AC, Figueira L, Martins MH, Loureiro F, Pinto MM, Coelho AC. (2014) Survey of *Mycobacterium avium* subsp. *paratuberculosis* in road-killed wild carnivores in Portugal. *Journal of Zoo and Wildlife Medicine* 45 (4): 775-781. doi: <http://dx.doi.org/10.1638/2014-0010.1>
- [11] Cardoso L, Cortes H, Eyal O, Reis A, Lopes A, Vila-Viçosa M, Rodrigues P, Baneth G. (2014). Molecular and histopathological detection of *Hepatozoon canis* in red foxes (*Vulpes vulpes*) from Portugal. *Parasites & Vectors*, 7:113.

- [12] Lozano J, Casanovas JG, Virgós E, Zorrilla JM. (2013). The competitor release effect applied to carnivore species: how red foxes can increase in numbers when persecuted. *Animal Biodiversity and Conservation*, 36.1: 37–46.
- [13] Barrull J, Mate I, Casanovas JG, Salicrú M, Gosàlbez J. (2011) Selectivity of mammalian predator control in managed hunting areas: an example in a Mediterranean environment. *Mammalia* 75(5):363–369. doi:10.1515/MAMM.2011.052
- 
-

## Hands on Action-Research in Construction of the Teaching Profession: A Scientific Contribution in the Initial Teacher Training of the University of Madeira (UMa)

MFB Pestana-Gouveia, P Brazão  
University of Madeira, Portugal  
Fernandapg2@sapo.pt, pbrazao@uma.pt

**Abstract.** Action research is more than just a method of searching scientific knowledge in the field of Educational Sciences. It brings together multiple dimensions of educational practice which involves action, observation and contextualized and systematic reflection leading to curricular and organizational development, along with the construction of the teaching profession. Action research aims to find solutions to emerging problems through the creation of curricular strategies that promote pedagogical innovation and improve learning.

The Master's degree in Preschool Education and Primary Education at the University of Madeira is based on these assumptions and has a curricular unit named Action Research Project which is implemented in real contexts of Pedagogical Practice in schools.

This paper is intended to report the beginning of this reflexive process in an attempt to broaden the discussion of teacher training to new audiences. It is important to examine experiences of the use of action research, starting from the diagnosis of problems, passing through the collection and analysis of data as well as the systematization of processes and knowledge and culminating in the realization of scientific reports.

**Keywords.** action research; education; scientific method; teaching profession.

### 1. Action-Research in education: conceptions, objectives and benefits

There are many definitions about Action-Research (A-R). All share the idea that consists in an investigation that encourages critical reflection on the educational activities in order to improve it and build new ways of educational intervention. This research seeks to address the needs and problems detected in

educational contexts where the teacher acts (Esteves, 1986; Carr & Kemmis, 1988; Elliot, 1996; Stenhouse, 1991; Bogdan and Biklen, 1994; Sandin, 2003; Carr, 2006; Máximo 2008; Nofke & Somekh, 2010).

Sandín (2003) points out seven general lines that synthesize the various conceptions:

- It aims to transform and improve educational practice. This is object of investigation;
- It features by a change of that develops by successive cycles, each cycle consists of four phases: planning, action, observation and reflection;
- Goes from real problems of educational practice, affecting teachers and students;
- It is based on reflection of communities, so it is considered a collaborative research;
- Involves a systematic reflection on the reality to transform it;
- It is developed by the people of practice, enabling a link between theory and practice;
- This research process is also training;

Thus, it can be said that A-R promotes teacher professional development, as it allows to build scientific-pedagogical knowledge and reflect on their role in the educational process (Sousa, Alonso and Roland, 2013). "*O objetivo da investigação científica é não só descobrir e descrever acontecimentos e fenómenos, mas também explicar e compreender por que razões tais fenómenos ocorrem*" (Jesuino, 1988, p. 215).

It is therefore a dynamic and interactive process, admitting adjustments resulting from the analysis of the phenomena being studied in a collaborative work

According Ferrance (2000, p. 6), A-R is:

a collaborative activity among colleagues searching for solutions to everyday, real problems experienced in schools, or looking for ways to improve instruction and increase student achievement. Rather than dealing with the theoretical, action research allows practitioners to address those concerns that are closest to them, ones over which they can exhibit some

influence and make change.

## **2. Action research: from education to science**

It can be argued that A-R is a "critical educational science" (Carr & Kemmis, 1988), as it allows the teacher to research, evaluation and reflection of his/her practice, stimulating innovation of the educational process and his/her own professional development. To Alonso (2007, p.118) "*os professores são desenhadores do seu próprio crescimento profissional e pessoal*".

The action research "is a systematic scientific research and self-reflective carried out for practical, to improve the practice" (McKernan, 1998, quoted by Max-Esteves, 2008, p.20). Different from the positivist and interpretative paradigm, so is not identified with the excessive and neutrality objectivism, as well as the subjectivity (Coutinho, 2005).

According to Máximo-Esteves, 2008, p.20). A-R involves a working methodology consisting of "(...) formular questões relevantes no âmbito da sua prática, para identificar objetivos a prosseguir e escolher as estratégias e metodologias apropriadas, para monitorizar tanto os processos como os resultados" (pp.9-10).

"*A Investigação-Ação é uma metodologia caracterizada por uma permanente dinâmica entre teoria e prática em que o professor interfere no próprio terreno de pesquisa, analisando as consequências da sua ação e produzindo efeitos diretos sobre a prática*" (Alarcão, 1996, p.116). The teacher engages in a cyclical process of think-do-think to investigate and create change, given that "*o conhecimento profissional prático é uma janela para uma melhor compreensão e apropriação da prática profissional*" (Oliveira-Formosinho & Formosinho, 2008, p. 8). To perform an A-R project it is essential to develop various procedures, starting from issues that define the problems to be studied. Then it should be done a literature review to gather the necessary information. Follows the definition of the methodology to be implemented and the data collection. Then the data is organized and interpreted.

According to Fortin (2009) the data collection can consist of observations, non-

structured interviews, registers or published texts, promoting the discovery of new phenomena by the investigator.

The analysis of the data occurs from the initial stage of collecting data and extends throughout the investigation. The investigator examines and organizes trying to understand. These data are validated through triangulation. Sousa (2005) "*(...) refere-se a uma metodologia de investigação em que se observa o mesmo fenómeno de três (ou mais) pontos diferentes, por diferentes observadores e com diferentes instrumentos*" (pp.172-173).

## **3. The reflective teacher in a changing school**

At the beginning of the XXI St. century pedagogical thinking about school and about its social role has emphasized the view of learning organization, able to reflect its mission, its practices with a view to promoting contextualized and meaningful learning for its students. This thought came to oppose the previous view of the school as an institution that promotes learning (Leal and Fonseca, 2013).

From this perspective, teachers and students must report their own training needs and develop self-development processes, rethinking their role as curriculum mediators, reflective agents in a reflective school (Alarcão, 2000) and curricularly intelligent (Leite, 2003). Reflection on the curriculum happens with the onset of collaborative action-research in order to develop the actors in their work and undertake new change of direction (Leal and Fonseca, 2013).

While agents engaged in learning in action, teachers should assume greater responsibilities in the planning and evaluation of their learning experiences, through reflection on practice and about practice, in a permanent alertness, as Perrenoud (1999) states, faced with problematic situations or dilemmas. In this process of reflection teachers can take various phases, according to Smith (1991): describe the action itself, to report on what it means to this action; confront realizing why this action and rebuild the action, trying to act differently. The teachers involved in the affirmation of identity and authorship unleash the school perspective as constant change. Reflective practice can also be understood as a process

of liberation of the profession routines to invite teachers to take an active role in the construction of their professional identity.

Research-action translates then into a strategic potential for the process of learning and development of teachers. It is the commitment to change that results in the quality of teachers, teaching quality and school improvement.

#### **4. Challenges of Action-Research in initial teacher education**

The professional development of teachers is a continuous process of knowledge construction that begins in the initial training. In this sense, Formosinho (2009) advocates greater link between research and teaching by immersing students in scientific research methods, in order to make them more reflective and responsive to the diversity of educational contexts, to make them to connect theory and practice, and to help in the diagnosis and resolution of emerging issues. For Alonso (2013) it is developing practical synchronized with the ecological contexts and community schools, with significance for the formation and the comprehensive development of students as citizens.

The challenge of A-R to be taken either by the student interns or by qualified teachers in practice can take a variety of approaches, Hatton and Smith (1995) such as: projects of A-R; case studies and ethnographic studies on students, on teachers, on the classes or on schools; curricular structuring measures; microteaching and other experiences on supervised practice.

With proper ethical care in the training of young teachers, these strategies can enhance your voice for reflection on the problems they intend to solve or about the evaluation of the triggered actions. The creation of collaborative research and learning cultures constitute a major challenge to student interns for the real complexity and implies a shared vision of the potential and contextual constraints of work.

#### **5. The experience at the University of Madeira**

The Master's degree in Pre-School Education and Training of the 1st cycle of basic education at the University of Madeira

introduced from the academic year 2013-2014 in its training plan a curricular unit under the name of A-R. In this, curricular unity students have the opportunity to consolidate their training, exercising skills in pedagogic practice with strong relationship between theory and practice, between action and reflection on and action. The work culminates in a final report to be presented and defended in public in the third semester of the course.

At the beginning of the semester, the first sessions of the course aim to clarify and discuss the basics of research in education and also the conditions for the development of A-R. Then are promoted individualized tutoring or group processes for the design and monitoring of the project.

In an analysis of the constraints relating to the practices of student interns, expressed by them in the reports we found the following:

- We found up problems associated with the definition of a relevant problem and its own definition.
- We found problems in managing time available for project implementation of A-R. Students revealed that the practice time is short for the full development of the project.
- We found problems in reflection as action assessment process: the construction phases of reflective discourse on the information on the meaning of information on the evaluation and on the reconstruction of action in different way.
- We found difficulties in the involvement of actors in educational practice with implications for the continuity of the project after the departure of training student. The implementation of collaborative research and learning cultures are one of the biggest challenges for student interns. It implies a shared vision of the potential of the constraints of work contexts.

#### **6. Issues for important further for the development of this project**

This project is crucial in initial teacher education at Master's degree in Pre-School Education and Training of the 1st Cycle of Basic Education of the University of Madeira. We assume continuity putting new issues to the development of the project:

On the formulation of the problem:



How to enhance the critical view of the students in the construction and formulation of problem?

On the time for implementation of the project:

How to best suit the action to the project time available to accomplish it?

On the framework of reflection on practice:

What will be the best support to provide students in various stages of construction of reflective discourse on their practice?

On construction of a culture of cooperation in action-research:

How to promote a culture of cooperation to ensure better support to the action-research developed by the students and ensure the continuity of this work?

## 7. Important ethical issues

According to Sousa's, Alonso and Roland (2013) this research process implies an ethic of responsibility. The student as a person is at the centre of education as it is an "*ser intersubjetivo que necessita desenvolver gradualmente a autonomia, a sua responsabilidade e a sua capacidade de intervenção consciente e crítica na realidade para a transformar*" (Sousa, Alonso e Roldão, 2013, p. 82).

It is therefore important that teachers are aware of the "power" that his action means when it comes to meeting the needs of students and meet their weaknesses, because acting in the present this will contribute to a better future.

## 8. References

- [1] Alarcão I. Formação Reflexiva de Professores. Porto : Porto Editora; 1996.
- [2] Alonso L. Desenvolvimento profissional dos professores e mudanças educativas: Uma perspetiva de formação ao longo da vida In Flores MA & Viana I. Orgs. Profissionalismo docente em transição: as identidades dos professores em tempos de mudança. Braga; Centro de Investigação em Educação da Universidade do Minho; 2007. p. 109-129.
- [2] Alarcão I. Escola reflexiva e supervisão. Uma escola em desenvolvimento e aprendizagem. In Alarcão I, org. Escola Reflexiva e Supervisão. Uma Escola em Desenvolvimento e Aprendizagem; Porto: Porto Editora; 2000. p. 11-23.
- [1] Bogdan R, Biklen S. Investigação qualitativa em educação. Porto: Porto Editora. 1994.
- [1] Carr W, Kemmis S. Teoria crítica de la enseñanza: La investigación-acción en la formación del profesorado. Barcelona: Martinez Roca; 1988.
- [3] Carr W. Philosophy, methodology and action research. Journal of Philosophy of Education 2006; 40 (4), pp. 421-435.
- [1] Coutinho C. Percursos de Investigação Educativa em Portugal – uma abordagem temática e metodológica a publicações científicas (1985-2000). Braga: Universidade do Minho; 2005.
- [1] Elliot J. El cambio educativo desde la investigación-acción. Madrid: Morata; 1996.
- [4] Esteves A. A investigação-acção. In Silva AS, Pinto JM. Orgs. Metodologia das Ciências Sociais. Porto: Afrontamento; 1986, p. 270-278.
- [1] Ferrance E. Action research. Providence: Brown University; 2000.
- [4] Formosinho JA. Academização da Formação de Professores. In Formosinho J. Coord. Formação de Professores: Aprendizagem profissional e acção docente. Porto: Porto Editora. 2009.
- [1] Fortin MF. Fundamentos e Etapas do processo de Investigação. Lisboa: Lusodidática; 2009.
- [3] Hatton N, Smith D. Reflection in teacher education: Towards definition and implementation. Teaching and Teacher Education; 1995. 11 (1), 33-49.
- [4] Jesuíno JC. O Método Experimental nas Ciências Sociais. In Silva AS, Pinto JM. Orgs. Metodologia das Ciências Sociais. Porto: Edições Afrontamento.1989. pp. 215-249.

- [1] Jonas H. Le principe responsabilité: Une éthique pour la civilisation technologique. Paris: Éditions du Cerf; 1995.
- [4] Leal S, Fonseca JA. Investigação-Ação como Instrumento de Desenvolvimento Profissional. In Sousa F, Alonso L, Roldão M; 2013. Investigação para um currículo relevante. Coimbra: Almedina. 2013, p. 163-177.
- [1] Leite C. Para uma escola curricularmente inteligente. Porto: ASA; 2003.
- [1] Máximo-Esteves L. Visão Panorâmica da Investigação-Ação. (Col. Infância). Porto: Porto Editora; 2008.
- [1] Nofke S, Somekh B. Handbook of educational action research. London: SAGE; 2010.
- [4] Oliveira-Formosinho J, Formosinho J. Prefácio: A investigação-acção e a construção de conhecimento profissional relevante. In Máximo-Esteves L. A Visão panorâmica da Investigação-Ação. Porto: Porto Editora; 2008. p. 7-14.
- [3] Perrenoud P. (1999). Formar professores em contextos sociais em mudança: Prática reflexiva e participação crítica. Revista Brasileira de Educação (12), 5-21.
- [1] Sandín M. Investigación cualitativa en educación: Fundamentos Y tradiciones. Madrid: McGraw-Hill; 2003.
- [1] Sousa A. Investigação em Educação. Lisboa: Livros Horizonte; 2005.
- [1] Sousa F; Alonso L, Roldão MC. Investigação para um currículo relevante. Coimbra: Almedina; 2013.
- [1] Stenhouse L. Investigación y desarrollo del curriculum (3ª ed.). Madrid: Morata; 1991.
- 
- 
-

## Hands-on Mathematics with Lego Robots

*S Martins<sup>1</sup>, E Fernandes<sup>2</sup>*

*<sup>1</sup>Middle and Secondary School Ângelo Augusto da Silva, Portugal*

*<sup>2</sup>University of Madeira, Portugal,*

*<sup>1</sup>smpcm@netmadeira.com, <sup>2</sup>elsa@uma.pt*

**Abstract.** In the research related in this paper it was designed and implemented a learning scenario, with two primary school classes (40 students), working together with Lego robots (NXT and RCX models). In this paper we intend to discuss and to reflect how the use of robots can contribute to mathematical learning in primary school students and to develop their mathematical competence.

**Keywords.** Mathematics, Robots, Situated Learning.

### 1. Introduction

Due to the on-going technological change we are witnessing, the created learning scenarios are increasingly different, making use of educational technological resources. Taking this into account, there have been a growing number of researchers interested in analysing the learning phenomena when students interact with those tools.

The use of Lego robots as a tool for learning basic science and mathematics concepts and also for developing scientific inquiry skills for students has recently drawn the attention of many researchers. However, few studies are focusing on how robots support primary school students to learn when they participate in project work activities.

Using ideas of situated learning from Lave and Wenger [1], [2], we intend in this paper to discuss and reflect how the use of robots can contribute to increase mathematical learning in primary school students and to develop their mathematical competence. The developed activities followed a project work methodology. The nature of the research is qualitative and it was given particular relevance to the process and not to the product of the developed activities.

### 2. About Learning

One of the most significant developments in educational approaches suggests that learning is taken as a process that emerges from specific situations and contexts.

Lave and Wenger [1], argue that learning is a social and cultural process, where it is relevant to shift "(...) the analytic focus from the individual as learner to learning as participating in the social world" (p. 43).

From this point of view, it is central the idea that learning is closely connected with participation in communities of practice, that are not only groups of persons but, are also communities of knowledge. According to Wenger [2], practice exists because there are people who participate in actions whose significance is mutually negotiated. It does not reside in a structure that precedes it, but "(...) resides in a community of people and the relations of mutual engagement by which they can do whatever they do" (p. 73).

Participation refers to a process of being active participant in the practices of social communities. Because of that, participation shapes not only what we do but also what we are and the way we understand what we do. Participation also shapes the communities in which we participate. In fact, "(...) our ability (or inability) to shape the practice of our communities is an important aspect of our experience of participation" ([2], p. 57).

Thus, a community of practice involves much more than the technical knowledge or skills associated with undertaking some task or activity. Members are involved in a set of relationships over time and communities develop around things that matter to individuals [2]. The fact that they are organized around some particular area of knowledge and activity gives members a sense of joint enterprise [1], [2]. This very specific aspect congeals the essence of the model of situated learning proposed by Lave and Wenger [1]. Learning and knowing involves a process of engagement in a community, thus, learning and knowing are social and comes largely from our experience of participating in daily life.

### 3. The Learning Scenario

The learning scenario was designed involving two primary school classes (2<sup>nd</sup> and 3<sup>rd</sup> grade, 24 and 16 students, respectively) from a school in Funchal – Madeira island – Portugal, working together with robots. This learning scenario was constructed all together by the research team, by teachers from both classes and by their students. The scenario's implementation was developed in two moments: the first between May and June 2011 and the second between April and July 2012.

We started the scenario's implementation with two primary school classes – Year 2 and Year 3. The second phase of scenario's implementation was in the following school year. The students were, at that time, in years three and four, respectively.

At this project students have worked with Lego robots: RCX and NXT. In both RCX and NXT models the programming environment is an icon-based drag-and-drop programming language, designed for an intuitive introduction to programming. By choosing program blocks that work with the motors and make the sensors react to inputs, students simply build up their program block by block, and they created programs that range from simple to complex. Students and teachers had never worked with Lego robots before.



Figure 1. Students building robots

Both classes have worked in heterogeneous working groups. Teachers had to support students in their work and the researchers sought to support students and teachers and to take advantage of situations that could contribute to the emergence of mathematical concepts. With that in mind, researchers assumed a questioning attitude towards students' work in the practice with robots.

In the first moment of scenario's implementation, students had to construct robots and define their physical and emotional features. Their creations will become

characters in a play-story written by them all. After writing the story students had to program their robots in order to perform their roles in the play. The initial goal was to accomplish those tasks in order to make a play with the robots as characters. The play was not done in this first moment of scenario's implementation.

In the second moment of scenario's implementation, students, teachers and researchers decided to make a film, using the produced play and followed the storyline.

Students established new tasks to produce the film and they created teams to accomplish those tasks. Each student has chosen in which team(s) they wanted to work in.



Figure 2. Students programming and testing



Figure 3. Students filming

Two teams were created to program the robots and one team for each one of the robots' models. The voices team was constituted by 10 students who gave voices to the 10 constructed robots. The voice team recorded the voices using the Microsoft Audio Recorder and chose the film's soundtrack. The film was edited, using the Windows Live Movie Maker, by the editing team. Some students were responsible for the filming and others were in charge of the lights. Based on the story written previously, the direction team wrote the script for the film and this team was also responsible for making the communication between all the involved

teams.

According to the created storyboard, students from both classes decided to build, in the art classes, the 'scenarios' needed for filming the movie.

All students decided that Year 3 class would construct the 'floor' in which filming will be made, and Year 4 class would be responsible for the 'vertical' scenarios. In order to accomplish those tasks, students explained to arts teachers from both classes how the robots will perform the scenes in the film, how they will move on the filming scenario and which environments would be necessary to create (a restaurant, a park, a castle, ...). The researcher followed and participated in the arts classes.

#### **4. Hands-on Mathematics with robots**

When teachers and researchers designed with students the learning scenario they didn't specified what mathematical contents would be specifically worked with scenario's implementation.

The idea was to design a project with robots based on a big theme: the construction of robots that were to be characters in a play-story written by them all (students from both classes). Both, teachers and researchers, believed that, this will provide students with opportunities to develop their ability to find as well as solve problems where mathematical contents (and others) will emerge in the ongoing practice.

Although mathematical contents have not been the tone for activities, it was intentionality shared by researchers and teachers to seek and to take advantage of times when the inclusion of the contents were significant and (or) emerged from working with robots.



**Figure 4. Students discussing robots' programming**

When students started the robots project, teachers were aware that Year 2 students haven't yet learned how to make conversions between different measures of time (hours, minutes and seconds). Because robots' programming was made by defining the time (in seconds) in which motors and sensors will produce some outputs, that knowledge emerged from programming robots.

Students needed to make those conversions between minutes and seconds more frequently to better program the robots' actions.

By programming robots, students learnt to predict how a robot will move from one place to another, by establishing time and directions for that action. Robots programming was a very productive field for mathematical concepts' emergence such as positioning, orientation, duration, trajectories, direction and movement. By dealing with robots was a powerful opportunity to make students solving mathematics problems in a very specific context.



**Figure 5. Robots moving in lines and roundabouts**

When students were filming in the second moment of scenario's implementation, they wanted to put roundabouts and streets to define robots' trajectories (Fig. 5). This intention emerged when Year 3 students were working on arts classes, creating the 'floor' for the filming.

The researcher knew that those students had not studied yet the circumference and lines' positions in their regular classes. The construction of roundabouts and streets on the floor seemed to represent a good way of students discuss and expand those mathematical topics.



By assuming that, the researcher talked with Year 3 teacher and with the arts teacher and purposed that the construction of roundabouts and streets could be made both in regular classes and in arts classes. This interdisciplinary was essential to promote the discussion about mathematical issues that emerged from constructing the scenarios required for the filming.

In regular classes Year 3 students analysed how they could construct the roundabouts using circumferences. This situation led to the discussion of certain mathematical topics such as the study of the circumference elements and its definition (radius, diameter, chord, arc,...). At that moment, those students also learnt how to use compass to perfectly draw circumferences. Those mathematical topics had not been studied before in the Year 3 classes. Its study emerged from the work with robots and from students' willingness of programming robots to move in roundabouts.

There was also a connection between the way the lines were placed on the floor (Fig. 5) and how students claimed that robots would be programmed to travel over them. The parallel lines emerged from students not wanting that certain robots met each other's when they were moving across them.

Students noticed that it was possible that two robots moving in two intersecting streets (lines) would not find each other. However, students concluded that if it was a requirement that two robots would not find each other it will be easier to guarantee it if they were moving in two parallel lines, instead on intersecting lines. In terms of programming, by using parallel lines, students would not have to worry about time and distance so that the robots do not meet each other.

Once again, in this moment of scenario's implementation, Year 3 students had not studied yet the mathematical definition of the lines positioning. Those students were talking about those lines (streets) but they didn't used the mathematical terms such as parallel or intersecting lines. That terminology was used by the Year 4 students when they were talking about the positioning of the streets (lines) on the floor.

Researcher and teachers promoted the discussion between students from both classes

about those words and their meaning in mathematics. The meaning of parallel and intersecting lines was negotiated in the practice of constructing the floor (in arts class) in which the robots would be moving in the filming.

It surely has been a great contribution to students' mathematics learning that this learning scenario was designed involving students from two different school levels, working together with robots. The position of Year 4 students represented a significant contribution to the emergence of mathematical contents on the school practice of Year 3 students. The study of the lines was a great example of it.

Students of Year 3 expanded their knowledge about lines and started using a mathematical vocabulary that was from now on shared by all students that were working on the project. On the other hand, students from Year 4 needed to make those contents clear to others, contributing so that these specific topics also become clearer to themselves.

## **5. Conclusions**

Modern technologies are changing the world we live on, as a result also give us a multitude of tools and ways of learning.

In this learning scenario, robots transformed the way students and teachers participate and the forms they were engaged in a school practice [3].

The use of robots in this learning scenario contributed to the emergence of mathematical concepts, and others. Robots were a powerful tool to students perceive, use, expand and talk about mathematical concepts.

Despite the contributions that robots brought to this learning scenario, we cannot disregard the working methodology advocated. Our positioning towards learning – as participation in social practices – led to a working methodology with certain characteristics that potentiate the learning scenario. Cooperation and interdisciplinary activities that characterized the project, formation of heterogeneous working groups, with students from both classes, positioning of teachers and researchers, decision-making and a negotiated sense of responsibility and accountability were certainly aspects that potentiate this learning



scenario [4].

By arguing that learning occurs when people participate in social practices, we may say that there are many aspects that we identify as mathematics learning. Mathematics learning implies the learning of mathematical concepts but also the way students use them to solve problems and the way they negotiate the meaning of those concepts in different school practices (mathematical or not) [5].

There are many other components that we assume as crucial to mathematics learning, beyond the learning of mathematical concepts, as we mentioned above. To communicate mathematical ideas in a coherent manner and with a correct vocabulary, to test hypotheses and formulate conjectures, to evaluate statements and strategies from others, to develop and evaluate inferences, are essential aspects that we identify as mathematics learning. Throughout scenario's implementation, it became clear that many of these aspects have emerged naturally in a natural way, in the way students participated.

## 6. References

- [1] Lave J, Wenger E. *Situated Learning: Legitimate Peripheral Participation*. New York: Cambridge University Press; 1991.
- [2] Wenger E. *Communities of Practice: Learning, Meaning and Identity*. Cambridge, UK: Cambridge University Press; 1998.
- [3] Martins S. 'Regime of competence' in a school practice with robots. In: *Proceedings of the Working Group 10. Cerme 8. The 8th Conference of European Research on Mathematics Education*; 2013 Feb 6 - 10; Antalya, Turkey: Starlight Convention Center, Thalasso & Spa Hotel; 2013. p1774-1783.
- [4] Martins S. Da escrita de uma história à produção de um filme. In E. Fernandes (Ed.), *Aprender Matemática e Informática com Robots*. (pp. 114 – 142). Funchal: Universidade da Madeira; 2013. [www.cee.uma.pt/droide2/ebook/index.html](http://www.cee.uma.pt/droide2/ebook/index.html) [visited 11-Jun-2015].
- [5] Fernandes E. Rethinking success and failure in mathematics learning: the role of participation. In: *Proceedings of the*

International Conference Mathematics Education and Society 5 (MES5); 2008 Feb 16 – 21; Algarve, Portugal: Hotel Baía Grande; 2008. p. 237-247.

---

---

## Mathematics Higher Education with Interactive Computing Resources

*L Camacho<sup>1</sup>, M Garapa<sup>1</sup>, JNM Ferreira<sup>3</sup>*

*<sup>1</sup>Escola B+S Padre Manuel Álvares,  
Madeira, Portugal*

*<sup>2</sup>Escola B+S Dr. Ângelo Augusto da Silva,  
Madeira, Portugal*

*<sup>3</sup>Universidade da Madeira, Portugal  
luiscmch9@gmail.com,  
marcogarapa@gmail.com, nelio@uma.pt*

**Abstract.** We have developed some computational and interactive resources, suitable for teaching mathematics in Higher Education.

In this paper we show some examples of these resources to be used in the context of a Calculus course and discuss the advantages of this approach in teaching. The examples presented in this paper allow students to explore, from a geometrical point of view, the mathematical concepts of limits and of partial derivatives of functions in two variables.

**Keywords.** Computational Interactive Resources, Higher Education, Mathematics.

### 1. Introduction

Over the last years we have seen a great technological evolution. This evolution has influenced the way we live causing profound changes in our society. It changed the way we interact and how we live, having also produced profound changes in the way we teach and learn. The potential use of technology in education is evident and calls for a change in teaching methodologies.

In higher education the need to change teaching practices was also felt in order to explore the potential of technology. For example, David M. Harrison of the Physics Department at the University of Toronto – Canada, created a large number of animations that students use during classes to better understand physical phenomena [2], [3].

Many authors have advocated the importance of using technology in the teaching of mathematics. For example: “Visualization, numerical and graphical experimentation, and other approaches have changed how we teach

conceptual reasoning in fundamental ways” (from [1]). “Technology is an essential tool for learning mathematics in the 21st century, and all schools must ensure that all of their students have access to technology” (from [4]).

Starting from these premises, we developed computational resources to provide support to the study and understanding of Mathematical concepts taught in Higher Education. In this article we will present some examples of these resources, adequate for the teaching of a Calculus course. With these examples it is intended to address mathematical concepts by exploiting the potential of technology in terms of three-dimensional representation and characteristics such as interaction and manipulation. These resources make the learning process more dynamic, allowing the manipulation of objects and performing simulations, which in turn contributes to a better understanding of abstract concepts.

### 2. Developed computational resources

In this section we present some of the computing resources that we have developed and we will explain what is expected to achieve with them and the advantages they bring to the understanding of mathematical concepts. The examples in this section address, from a geometrical point of view, the mathematical concepts of limits and of partial derivatives of functions in two variables. Using these resources, the students are invited to explore and to draw their own conclusions and, thus, obtaining a better understanding of the notions and properties.

#### 2.1. Limit of a scalar function in two variables

In the following example, students can explore what is happening to the values of a function when  $(x,y)$  approaches  $(0,0)$  using different directions. More specifically, they can use a family of lines  $y=mx$ . Using a slider, they can change the value of  $m$ , the slope of the lines. The limit of the function along the path is displayed as dynamic text which automatically changes according to different values of  $m$ . Using this dynamic figure, students can see that the value of the limit depends of the chosen path.

Below we present a sequence of snapshots that illustrates the example.

This example can help students understand that the limit of a function must be independent of the path or direction chosen in the approach. That is, if different trajectories lead to different values then the limit does not exist. At this moment it is important to ask questions such as: what happens if the values of the function always approach the same value when using the family of lines passing through the point? Can we conclude that this value is the limit of the function? The next example will allow students to investigate these questions.

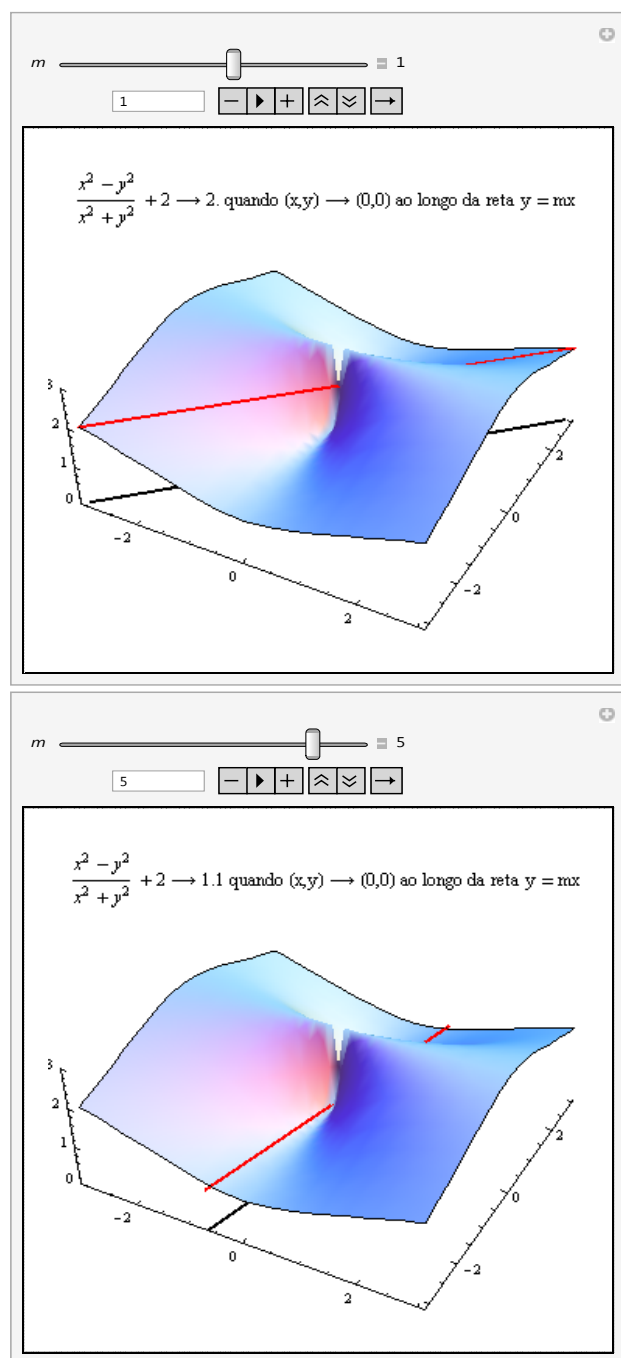

## 2.2. Geometric Interpretation of Partial Derivatives

In this example, students will explore from a geometrical point of view the concept of partial derivative of a function  $f$  at a point  $(x_0, y_0)$ .

The students can show or hide the planes  $x=x_0$  or  $y=y_0$  using checkboxes. They can use sliders to change the values of  $x_0$  and  $y_0$ . It is also possible to rotate the 3D graphic. The presented graph adapts to the selected options showing the surface (the graph of  $f$ ), the selected plane ( $x=x_0$  or  $y=y_0$ ), the curve  $C$  that results from the intersection between the surface and the plane, a movable point  $(x_0, y_0)$  and also the tangent line to the curve  $C$  at  $(x_0, y_0, f(x_0, y_0))$ .

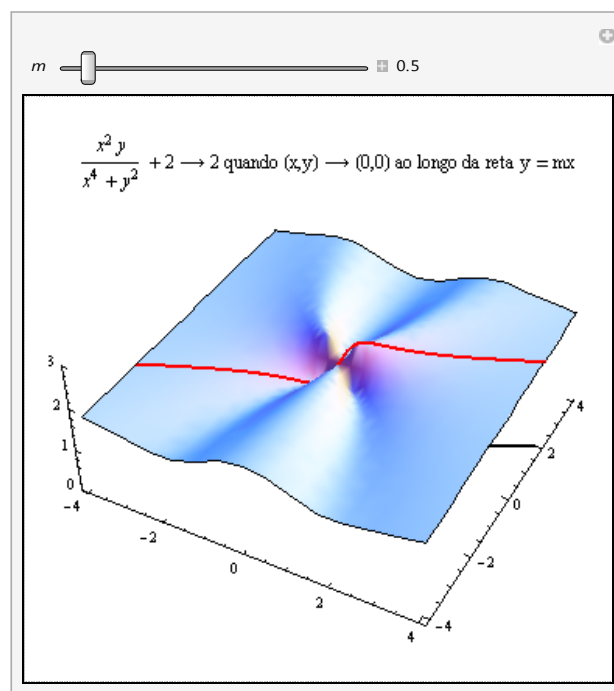

The students can explore this example guided by a list of questions such as: What is the black curve represented in the surface? What seems to be the straight line represented in the graph? What do you think is the relationship between the straight line represented in the graph and the partial derivative of  $f$  with respect to  $y$  at  $(x_0, y_0)$ ? What is the sign of the partial derivative of the function with respect to  $y$  at  $(-1, -1)$ ?

It is expected that the exploration of the example and the answer to the proposed questions will allow a better understanding of the geometric aspect of partial derivatives. Also, it is useful for seeing the connection between this notion and the already known

concept of derivative of a function in one variable.

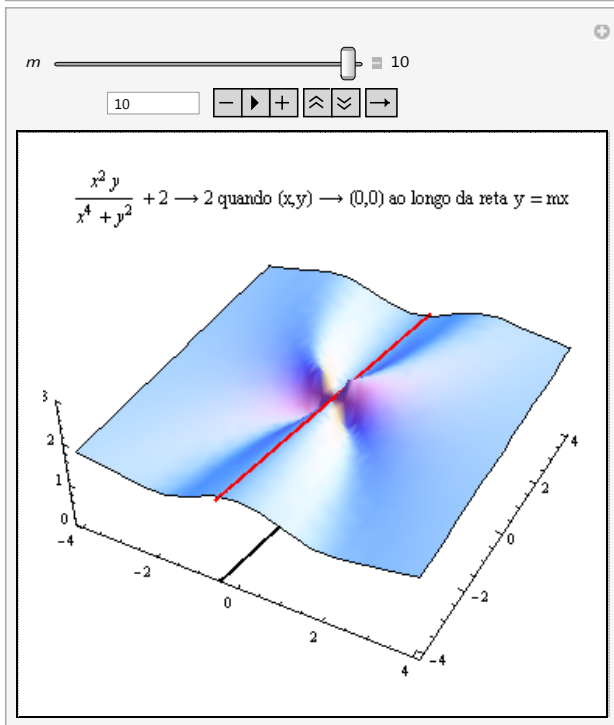
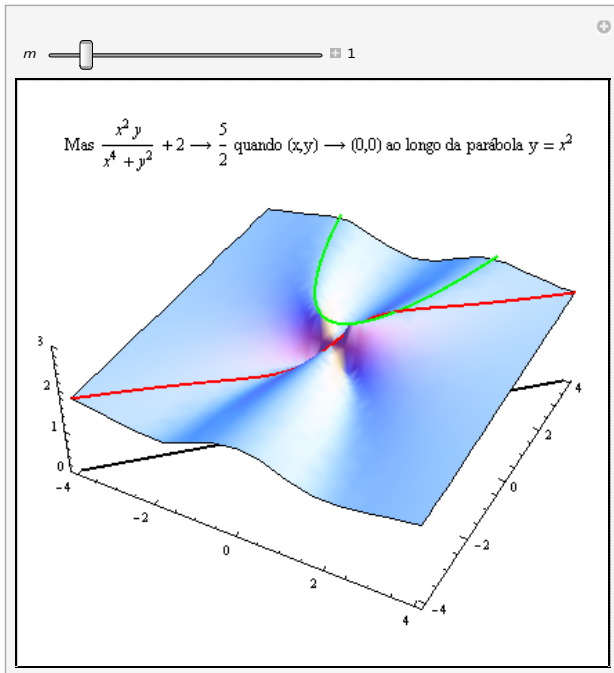

### 3. Technical Aspects

Some of the resources were created by us and others are a result of adaptations from Wolfram Demonstrations Project [5] and [6]. To create the resources presented in this article we have used Mathematica because of its three-dimensional representation features. These files were stored in the CDF format allowing free access to all users even if they do not have the Mathematica software installed in

their computer. They just have to install the CDF Player, which is free and can be downloaded from the Wolfram site.

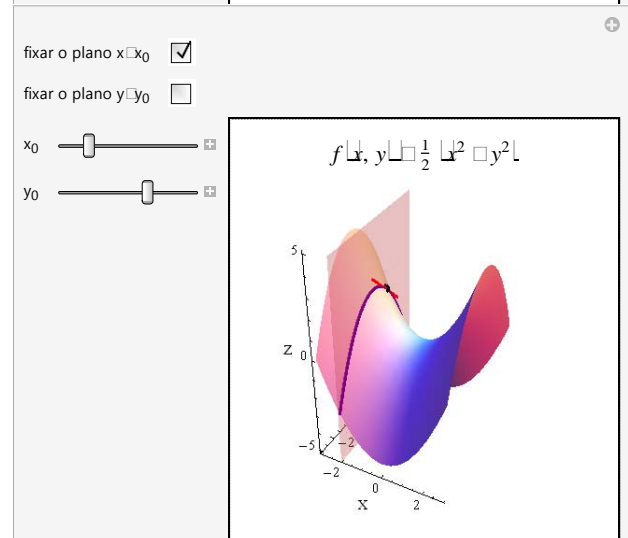
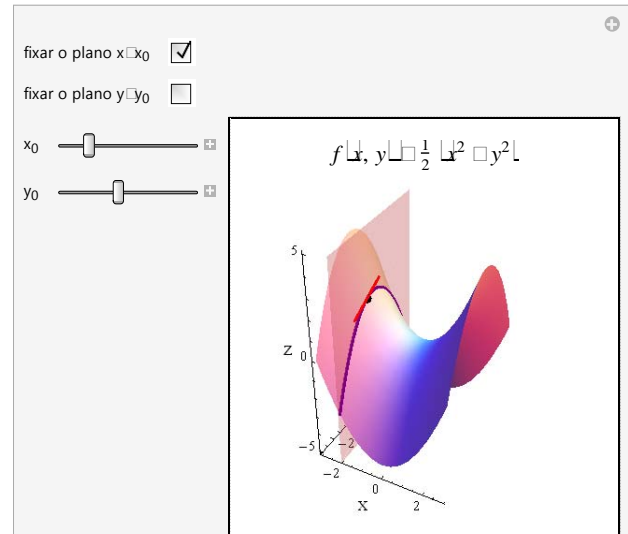

### 4. Future Work

Throughout this article we have presented some examples of interactive computing resources. We are currently developing an interactive set of lecture notes for a Calculus course taught at the University of Madeira. These lecture notes will contain the interactive resources accompanied by guiding tasks for the students. Despite being an ongoing project, we believe that this will be a useful tool to support the teaching since it will create a more productive educational environment, where students can view, manipulate, and interact with different objects and therefore, promoting a better understanding of concepts (see also [8]). We shall analyze the effect of this approach in the students' learning process.

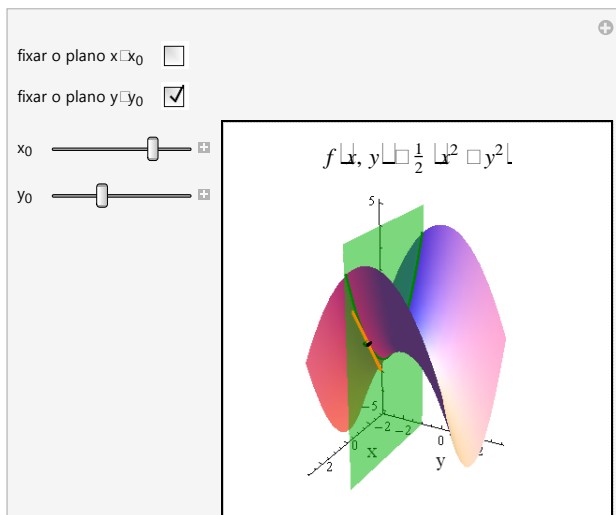

## 5. Conclusion

There are many references to the use of technology in teaching mathematics. For example, we quote a recommendation of the National Council of Teachers of Mathematics (NCTM) [13]: “Technology is essential in teaching and learning mathematics; it influences the mathematics that is taught and enhances students’ learning”.

We have developed some computational and interactive resources, suitable for teaching mathematics in Higher Education. These resources allow the learning process to be more dynamic since it involves manipulation of objects and simulations, which in turn contributes to a better understanding of abstract concepts.

We believe that this will be a useful tool to support the teaching of the course by providing an educational environment where students can take an active role in their learning, through the visualization and interaction with different objects.

## 6. References

- [1] Stewart J. Calculus. Brooks/Cole Publishing Company; 1995.
- [2] Harrison DH. Flash Animations for Physics; 2011.  
<http://www.upscale.utoronto.ca/GeneralInterest/Harrison/Flash/> [visited 2-Jun-2015]
- [3] Harrison DH. I Encontro Internacional da Casa das Ciências; 2013 Mar 21-22; Lisboa; 2013.
- [4] National Council of Teachers of Mathematics. The Role of Technology in the Teaching and Learning of Mathematics; 2008.
- [5] Brown A. Partial Derivatives in 3D from the Wolfram Demonstrations Project. <http://demonstrations.wolfram.com/PartialDerivativesIn3D/> [visited 15-Apr-2014]
- [6] Lynch LR. Nonexistence of a Multivariable Limit from the Wolfram Demonstrations Project; 2014.  
<http://demonstrations.wolfram.com/NonexistenceOfAMultivariableLimit/> [visited 15-Apr-2014]
- [7] Hohenwarter M, Hohenwarter J, Kreis Y, Lavicza Z. Teaching and Learning Calculus with Free Dynamic Mathematics Software GeoGebra; Proceedings of the 11th International Congress on Mathematical Education. Monterrey, Nuevo Leon, Mexico; 2008.
- [8] Gómez-Chacón IM. Visualización y razonamiento. Creando imágenes para comprender las matemáticas; In Martinho MH, Tomás Ferreira RA, Boavida AM, Menezes L. Proceedings of the XXV Seminário de Investigação em Educação Matemática; 2014 Apr 9-10; Braga; 2014. p. 5-28.
- [9] Correia P, Espadeiro RG. RED e Applets...partilha e apropriação dos recursos. Revista Educação e Matemática Nº117 2012; p. 42-44.
- [10] Hallett DH. Calculus at the Start of the New Millenium. Proceedings of the International Conference on Technology in Mathematics Education; 2000 Jul. Beirut, Lebanon; 2000.
- [11] Baumslag B. Fundamentals of Teaching Mathematics at University Level, London: Imperial College Press; 2000.
- [12] National Council of Teachers of Mathematics. Professional standards for teaching mathematics. Reston; 1991.
- [13] National Council of Teachers of Mathematics. Principles and standards for school mathematics. Reston; 2000.

## “Think Global Act Local” - an Experience of Environmental Education for Sustainable Development on Special Protection Zone of Samouco Saltworks

HC Carvalho-Pires<sup>1</sup>, IA Pinto-Mina<sup>2</sup>  
<sup>1</sup>Escola EB 2,3 Álvaro Velho, Barreiro  
<sup>2</sup>Universidade do Minho, Portugal  
hcpires@gmail.com,  
icapmina@bio.uminho.pt

**Abstract.** Located near Tagus estuary, in an area formerly rich in saltworks, the basic school EB 2,3 Álvaro Velho in Lavradio, Barreiro started to develop on 2013/14 the pedagogic project “Citizenship and Sustainable Development, Think Global, Act Local”.

In this context was born the club, “Friends of Nature”, to promote environmental education activities with the collaboration of schoolteachers from different disciplinary areas and community organizations like the Foundation for Environmental Protection and Management of Samouco Saltworks (FPGASS\*), National Reserve of Tagus Estuary (RNET\*) or the Barreiro town council (CMB\*). The field trips to Samouco saltworks organized by this club were opened to other publics and allowed the observation, on direct contact with nature, of the characteristic biodiversity of this ecosystem that acted as “an outdoor laboratory”. Using Learning Outside Classroom (LotC) methodology, generally through Inquiry Based for Science Education (IBSE), the success of the activities developed and listed on the club’s blog (<http://alvarovelho.net/cefjard/>), highlights that students have learned to appreciate this wetland, because they showed a conceptual change of their initial idea that, “wetlands are sludge ecosystem without life”.

**Keywords.** Environmental education, Learning Outside Classroom, Samouco saltworks, Tagus Estuary biodiversity.

### 1. Introduction

The basic school of 2<sup>nd</sup> and 3<sup>rd</sup> cycle - EB 2,3 Álvaro Velho in Lavradio, Barreiro – is located on Tagus estuary, occupying an area formerly rich in saltworks (Fig. 1). In 1790 this

estuary had 247 *marinhas*<sup>1</sup> that produced 104900 *moios*<sup>2</sup> per year [1]. The Portuguese salt reputation was huge, due to his whitest colour and low insoluble substances content. In our country, this salt was used in domestic activities and in industry, including the supply of national fleet cod fishing. But, the rapid industrialization of the zone that began in 1958, ended with the Barreiro’s saltworks. The landfill of these wetlands led to the loss of a great biodiversity, namely many clams like the Portuguese oyster (*Crassostrea angulata*) and the “lambujinha” (*Scrobicularia plana*) [2].

The saltworks or “marinhas” are included, since long time, in the estuary marginal landscape, revealing a strong connection between coastal community and its river. In addition, they housed a great biodiversity constituting an area of food supply and protection for many organisms. Safeguarding this heritage is to protect a site of natural beauty and preserve some of our cultural identity [3].



**Figure 1. Old saltworks; nowadays Avenida das Nacionalizações [2]**

To mitigate the environmental impact caused by the construction of the Vasco da Gama’s bridge was created in 2000, the Foundation for Environmental Protection and Management of Samouco Saltworks (FPGASS\*), beside National Reserve of Tagus Estuary (RNET\*). The recognition of the public interest of the natural heritage of this 360 hectare area allowed its inclusion in the special protection zone (ZPE\*) of Tagus declared under the Birds Directive [4]. The Salina complex of FPGASS consists essentially of a

<sup>1</sup> - Saltworks

<sup>2</sup> - Measure used by salt workers, equivalent to 750kg



series of tanks separated by artificial dikes and creeks, where the salt processing is handmade. In this ZPE there are also agricultural areas, a small forest spot and small patches of marsh and dune vegetation. Flamingos are the most popular waterfowls here observed, reason why they were chosen for the foundation logotype.

Beginning on 2014 the education project of Álvaro Velho' school, "Citizenship and Sustainable Development, Think Global, Act Local" has as main objective to acquaint students with the local environmental reality and, through the knowledge of the region history, guide the understanding of the causes of the rapid changes that took place on the last two centuries, on their residential area, Lavradio-Barreiro. In this context was born the sciences club, "Os Amigos da Natureza" (Friends of Nature), in order to incite several activities to promote environmental education. The 17 students of this club were able to compare neighbouring ecosystems with different conservation status – the ZPE on Samouco saltworks, the RNET and the Barreiro industrial area.

The field trips to Samouco saltworks organized by "Friends of Nature" were open to other publics and allowed direct contact with nature, to know *in loco* the characteristic biodiversity of this ecosystem that acted as "an outdoor laboratory". A multidisciplinary approach to environmental education was possible, attending to the active participation of several teachers that, within their disciplines, have prepared outdoor activities whose topics were further developed within their classes.

The activities carried out by the students of this club are described on a blog: <http://alvarovelho.net/cefjard/>, and some of them are here described and analysed.

## 2. Birdwatching

The birdwatching activity carried out on ZPE (Figure 2) was for some students the chance to see by the first time, waterfowls. The recognition of the importance of this habitat for migratory birds became obvious primarily for wintering species that find here, shelter, food and a nesting site. A convenient birds observation was made with binoculars and telescope and identification appealed to specific guides [5, 6, 7].

The knowledge acquired on key aspects of this ecosystem' dynamics triggered an increase of respect and regard for this ZPE originally seen as "just a muddy place".

Beyond the fascination with flamingos and the smaller birds previously overlooked, the donkeys from Miranda do Douro that are being bred on this ZPE, made the delights of all participants.



Figure 2. Birdwatching and its identification

## 3. Short film realization

During the field trip, the students of the sciences club, made a "short film" in order to share their experience of environmental education, with the colleagues that stayed at school.

Having emerged the opportunity to apply for the Portuguese Association to Environmental Education (ASPEA\*) project: "Dos Rios aos Oceanos: percursos entre muitas histórias", the club short film was the winner on the category of online public voting. This short film may be seen on:

[https://www.youtube.com/watch?v=CtjLSSkFW\\_c](https://www.youtube.com/watch?v=CtjLSSkFW_c)

The prize was a trip to "Centro Interpretativo da Serra da Estrela" and to the "cineEco of Seia", on the 10<sup>th</sup> October 2014. The ASPEA also promoted a meeting in "Parque Biológico de Gaia" to celebrate the World Environment Day – 5<sup>th</sup> june. A guide visit to this Biological Park was completed with the opportunity to know the work of colleagues from other schools on the environmental thematic.

## 4. Salt production

By *hands on* activities the students got knowledge about the history and culture of salt production. Individually or in teams, they manipulated objects related to the salt production process. They were “salt workers” for one day, conducting salt scraped (Fig. 3) and after that, weighing and packing the salt obtained.



Figure 3. Salt scraped with squeegee

Using diverse aromatic plants they also made salt aromatization (Fig. 4).



Figure 4. Salt aromatization

The success of these activities resulted in scheduling new sessions extensible to the rest of the school community, including teachers and employees. Despite the need to cancel the scheduled visit due to bad weather, this initiative will be held in the future as the considerable number of registrations evidences the great interest of the community.

## 5. Halophytes

The Learning Outside Classroom (LotC) methodology [8] used in this sciences club, was associated with Inquiry Based for Science Education (IBSE) methodology [9, 10], for the

study of the marsh plants. Data collection made by the students, during their observations, was performed by photographic records and written notes. Analysis of plants' characteristics allowed its identification with the help of some specialists. As it's not easy to find guides for identification of these plants that are salt tolerant, after the research on halophytes' special features, students made a poster summarizing the information gathered, to share their knowledge with the community.



Figure 5. *Salicornia ramosissima*



Figure 6. Hands on *Salicornia*

### 5.1. *Salicornia ramosissima*

Among the ZPE halophytes, *Salicornia ramosissima* (Fig. 5) is an edible one. It is a very nutritious plant with antioxidant and anticancer properties, being an alternative to salt, particularly interesting to hypertensive people.

This succulent plant with jointed and quite branched stems may be dark green, yellowish-green or even red-purple depending on their life cycle. Their opposing leaves are held together thru the stem forming a fleshy articulate. Its propagation is through seeds and/or stem

segments [11]. Known as “green salt” or “sea asparagus” its properties, namely the nutritional ones [12], made this plant a *gourmet* product that is being marketed in Portugal, with a considerable success.

### 5.1.1. Cookbook

With an extended knowledge about halophytes and having tasted the “sea’ asparagus” the students were stimulated to experimentation. In collaboration with the cooking club, several recipes with this ingredient have been tried (Fig. 6).

These experiences culminated with the publication of a cookbook by Santillana publishers, in June. The book entitled: «Somos o que comemos... (SAL)icornia, alternativa para uma dieta saudável» [We are what we eat...(Sal)icornia alternative to a healthy diet], was financed by Ilídio Pinho Foundation and has the collaboration of various partners.

To promote the parents participation on the scholarly life of their children’s and stimulate the sustained management of resources, a workshop will be realized to present the book and taste some of its recipes.

## 6. Conclusion

With these “Hands on” projects the students were able to acquire different kinds of skills:

- Development of scientific literacy; the syllabus learning through practical activities allow self-construction of learning;
- Conducting scientific work - aiming the development of procedural learning;
- Enhancement of social and personal development;
- Creativity stimulation through the expansion of new horizons;
- Increased awareness to environmental sustainability issues and consequent acquisition of responsible attitudes.

So, these methodologies must always be included on these learning levels’ curricula, although a better logistic and financial support is needed to allow its realization and improve its outcomes.

## 7. Acknowledgements

We would like to thank Sónia Correia collaboration in the projects of “Amigos da Natureza” club, namely the Project submitted to Ilídio Pinho Foundation and to Rui Sequeira, coordinator of the EcoEscolas projects. We are also grateful to the Cooking club as well as Fundação para a Proteção e Gestão Ambiental das Salinas do Samouco (FPGASS).

## 8. References

- [1] Lepière C. Inquérito. A indústria do sal em Portugal. Universidade Técnica de Lisboa, Lisboa; 1935 *in* Dias AA, Marques JMS. Estuários, Estuário do Tejo, o seu valor e um pouco da sua história. Reserva Natural do Estuário do Tejo. Instituto da Conservação da Natureza, Alcochete; 1999.
- [2] Luzia A. Lavradio e as suas gentes. Gráfica Lavradiense, Junta de Freguesia do Lavradio; 1994.
- [3] Dias AA, Marques JMS. Estuários, Estuário do Tejo, o seu valor e um pouco da sua história. Reserva Natural do Estuário do Tejo. Instituto da Conservação da Natureza, Alcochete; 1999.
- [4] Directive 2009/147/EC of the European Parliament and of the Council of 30 November 2009 on the conservation of wild birds. Official Journal of the European Union; 2010.
- [5] Lima M. A Reserva Ecológica Nacional do Concelho do Seixal: Contributos para a sua descrição e divulgação. Câmara Municipal do Seixal; 1997.
- [6] Lima M. Terras de Laurus: Encontros com o Património Natural e Ambiental do Concelho do Seixal. Câmara Municipal do Seixal, Plátano Editora; 1997.
- [7] Catry P, Campos A. Guia de Aves comuns de Portugal, Edição SPEA, Lisboa; 2010
- [8] Waite S. Teaching and learning outside the classroom: personal values, alternative pedagogies and standards, Education 3-13: International Journal of Primary, Elementary and Early Years Education 2011; 39: 1, 65-82.

- [9] INQUIRE. Manual para Professores e Educadores do Curso Piloto INQUIRE. Lisboa, Portugal; 2011.
- [10] Harlen W. Assessment & Inquiry-Based Science Education. Issues in Policy and Practice. Published by the Global Network of Science Academies (IAP) Science Education Programme (SEP); 2013.
- [11] Julião M. Avaliação do potencial de *Salicornia ramosissima* para saladas frescas ou em pó (sal verde). Dissertação de Mestrado em Tecnologia dos Alimentos – Universidade do Algarve; 2013.
- [12] Santos E, Pacheco J (coord.) Cultivo sustentável de salicornia na Reserva Natural do sapal de Castro Marim e Vila Real de Santo António. Programa POAlgarve 21. Loulé; 2014.

Note: \* Portuguese initialism or acronym





## Equilibrium and Stability in the Magnetic Field: Learning through an Out-of-Classroom Experiment

*D Castro<sup>1</sup>, D Fernández<sup>1</sup>,  
J Blanco<sup>2</sup>, BV Dorrió<sup>2</sup>*

*<sup>1</sup>Industrial Engineering Student*

*<sup>2</sup>University of Vigo, Spain*

*davidcp1989@hotmail.com,*

*damian10fg@hotmail.com,*

*jblanco@uvigo.es, bvazquez@uvigo.es*

**Abstract.** Each year, our students are asked to carry out a home-made experiment that must deal with some of the issues studied in the Physics lectures. This not only becomes an exciting assignment for them but also a source of creativity. Many of the experiments involve original solutions and create an opportunity to go deeper into different basic concepts. The experiment selected for this article was conceived and designed by the two students who are co-authors of this paper. It allows some topics of basic electromagnetism to be studied and experimented with. The objective of this work is to take advantage of a simple home-made experimental system for the development of active teaching and learning, based on a hands-on science experiment. The experiment consisted of the interaction produced between a wire coil and a magnet. In particular, the idea of equilibrium and stability of a dipole in a magnetic field is explored here. In addition, some other related concepts arise, such as eddy currents, relationships between the magnetic field created by a dipole and its magnetic momentum, diamagnetism, etc. Doing the experiment involved taking measurements, both dimensional and electromagnetic, assuming simplifying hypothesis and comparing theoretical and experimental results.

**Keywords.** Hands-on learning, home experiment, Problem-based learning, magnetic dipole, solenoid, magnetic force, equilibrium, stability, magnetic field measurement.

### 1. Introduction

The concepts of balance and stability are of great importance when understanding and modeling the behavior of many physical systems of different kinds. The fields of mechanics, electromagnetism and thermo-

dynamics are more easily explained when a point of view is taken that analyzes balance and stability on the basis of potential energy. Even when systems in evolution, and thus out of balance, are studied, both concepts are of help in the understanding the initial and arrival states, in addition to the fact that throughout the process the evolution of the potential energy function is an important factor to take into account.

For this reason we consider it to be important when teaching physics for students to reach an understanding of this approach, and acquire the ability to apply it when explaining the behavior of different types of physical systems. In this sense, it is necessary for them to know the difference between concepts of balance and stability, which are often confused in colloquial language. The student is usually drawn to an erroneous preconception that identifies balance with unstable equilibrium, in such a way that the only things in balance are "on the edge of falling". Students should also know that obtaining the potential energy of a system and studying the singular points of its mathematical function make it possible to predict its behavior. Calculation of the forces that are derived from this function leads to analysis of the system's response to external perturbations. In the case of stable balance these forces will tend to recover the initial state, whereas an unstable one involves keeping the system away from it indefinitely. Familiarizing students with these concepts means providing them with a tool to enrich their vision of the physical world and, therefore, will be of interest both for science and technology undergraduates, including those studying many fields of Engineering.

The work presented here is the result of a small-scale project carried out by two students in the first year of a General Physics Course at an Industrial Engineering School. Both are co-authors of this article. It was proposed that groups of two or three pupils in their class should devise a physics experiment that could be done in their own home, and then implemented in the classroom for all their classmates. They were also requested to give a simple explanation of the theoretical basis and explain details with the aid of a Power Point presentation. They were suggested a number of possible topics as well as bibliographic sources [1], including web pages [2]. The

initiative was well received by the students and we believe that it was an exciting task for most, both for the realization of the experiment itself and for its presentation in public.

The experiment, analyzed in a Problem-Based Learning approach [3], that has been selected to show here was conceived and designed by the co-authors of this paper. It is described below, and allows some topics of basic electromagnetism to be studied and experimented with. The objective of this work is to take advantage of a simple home-made experimental system for the development of active teaching and learning, based on a hands-on science experiment. It was decided, therefore, to preserve the simplicity of the students' initial design and to sidestep issues that could end up blurring the fundamental concepts which were the initial intention. Thus, the use of more complex and precise laboratory equipment has been avoided, and an attempt has been made to simplify the mathematical analysis of the experiment, in order to provide better clarity of the principles involved, since, at the end of the day, this work is designed for students of a first year General Physics course. Proper complementary information can be found in different bibliographic sources [4,5,6].

The fundamental element consisted of a lead wire wound around a plastic tube through which a voltage flows, and a magnet that is dropped inside. The students observed that the magnet entering the tube could be trapped at the height of the coil or be repelled by it, depending on the orientation of the magnet. In the first case, the magnet oscillates as if it was attached to an elastic spring. The students also found a copper tube that fitted well inside the PVC one, so they could do the experiment both with and without conductive tubing, without having to wind the cables again.

In our view, the study of this coil-magnet system makes it possible to analyze two equilibrium states, stable and unstable, as an application of knowledge concerning magnetism: the potential energy of a dipole in a magnetic field, the force of a magnetic field over a dipole, as well as the relationship between potential energy and the force. It will be shown that the potential energy of the magnet presents a maximum or a minimum in the center of the coil, depending on its orientation, and the force required to remove the magnet from the coil in steady state or to

overcome the force exerted by the coil on the magnet in the unstable one can be calculated. Swapping the PVC tube with the copper one also lets students observe the cushioning effect exerted on the movement of the magnet in its interior due to eddy currents generated in the tube when the magnet slides inside. Also the weak diamagnetic effect of copper was noted by measuring the field created by the coil both with and without copper.

## **2. Description of the experiments**

Experiments and measurements in this project were conducted with the following apparatus (Figure 1):

- A coil of wire coiled around a PVC pipe.
- The proper caliber of copper tubing to fit inside the PVC one.
- A DC power source.
- A multimeter in amperimeter mode.
- Four neodymium magnets attached in series.
- A teslameter formed by a Hall probe and digital readout driver.
- A dynamometer.

The first thing that students observed once current was passing through the coil was that when a magnet oriented in the same direction as the field of the coil was made to approach, it was attracted and trapped in the pipe and the height of the coil, and could oscillate around this position (Figure 2). They also observed the difference between doing this with only the PVC pipe and doing so with the copper one inside. In the former case the magnet should be introduced slowly so that it does not fall past the equilibrium position and escape through the opposite end of the tube. It is, therefore, preferable to attempt this with the tube in horizontal position: once the magnet is trapped, the tube could then be rotated into an upright position. On the other hand, they noted that with the copper tube there was no danger of the magnet escaping from the position of equilibrium since its movement was appreciably slower. In both cases, therefore, the force exerted by the field of the coil on the magnet was sufficient to compensate for the weight and prevent it from falling [Figure 1].

Subsequently, they made an approach with the magnet oriented opposite to the coil field: They noted, as hoped, that it was repelled, but



they tested to see that if it was forced through the coil, then it was rejected out of the opposite end of the tube. They also realized that the magnet had a tendency to turn in order to have the same orientation as the field, although this turn was hindered by the narrowness of the tube. This could jam it inside the tube and then the power had to be switched off to let the magnet come out.



**Figure 1. Main set-up: copper tube with a coil of wire coiled around a PVC pipe**

Initially, the students performed this experiment at home before presenting it to peers in class. However, as they showed interest in more accurate measurements to quantify the facts that they had observed, it was decided to carry it out in the physics lab using the measuring devices listed above. This gave an opportunity to focus on a number of basic concepts of magnetism, as well as their mutual relationships that have proven, in our view, to be very enriching.

The potential energy  $E_p$  of a magnet with dipole moment  $m_i$  within the magnetic field  $B_c$  produced by the coil is:

$$E_p = -\vec{m}_i \cdot \vec{B}_c \quad (1)$$

This is an expression in which the field can be approximated by a coil with a current intensity  $NI$  and radio  $c$ .

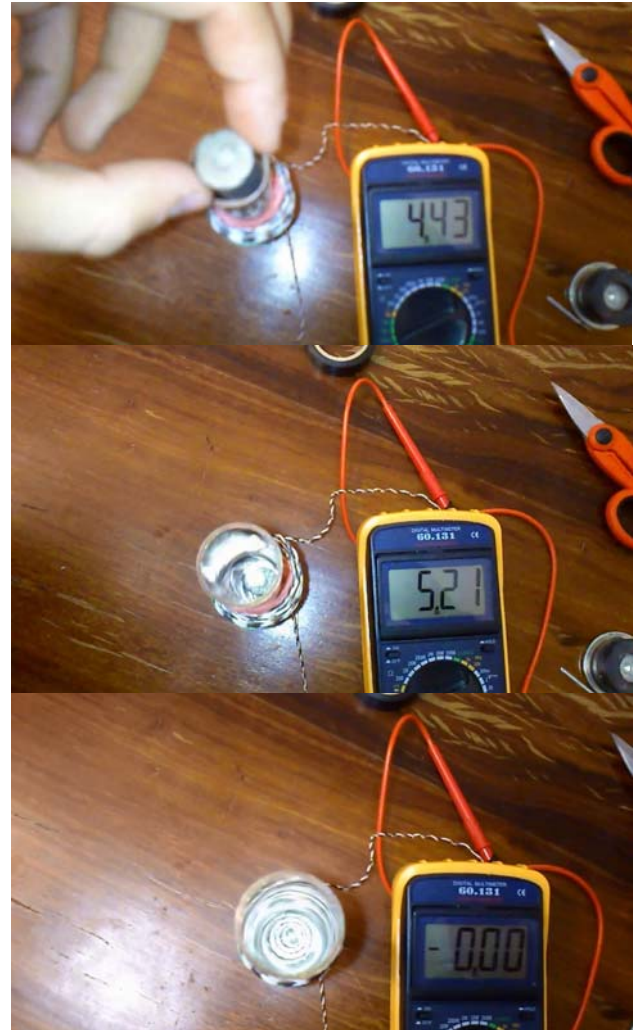

**Figure 2. Magnet attracted and trapped inside the copper tube**

This is justified by the fact that, as shown in Figure 1, the overlapping turns makes the winding rather concentrated, in such a way that  $c$  is really an average radius:

$$E_p = -m_i \frac{\mu_0 NI}{2} \frac{c^2}{(x^2 + c^2)^{3/2}} \quad (2)$$

where  $x$  is the distance from the median plane of the coil to a point on its axis. When this last expression is represented graphically, it can be seen that it corresponds to a well of potential in which a stable equilibrium position is the minimum of the mathematical function. If the magnet changes to an opposite orientation, the field of the solenoid would change its sign, in such a way that the balance point will be a maximum of the potential energy and the

equilibrium would become unstable.

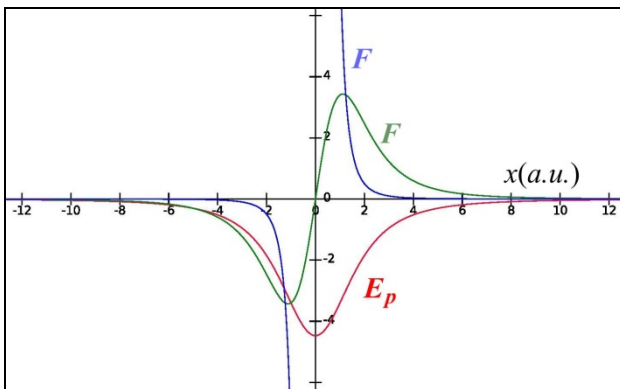

**Figure 3. Potential energy  $E_p$ , equation (2) and the strength of the magnet  $F$ , equations (3) and (4), as a function of the distance  $x$  from the median plane of the coil to a point on its axis**

The value of the strength of the magnet is obtained by using the expression [7]:

$$F = -m_i \frac{dB}{dx} = m_i \frac{\mu_0 N I c^2}{2} \frac{3x}{(x^2 + c^2)^{5/2}} \quad (3)$$

where  $x$  corresponds to the position of the center of the magnet. As in the expression of energy in equation (3), if the magnet is oriented in the same direction as the field produced by the coil, the force is recovering and tends to lead it to the equilibrium position. When the orientation of the dipole moment of the magnet is opposite to the coil, it implies a change in the direction of the force, which then tends to expel it from the coil. It is easy to show that the function of force presents a maximum for the position  $x=0.5 \cdot c$ .

On other hand, the force can also be calculated based on both dipolar momenta [8]:

$$F = \frac{\mu_0}{4\pi} \frac{6m_i m_c}{x^4} \quad (4)$$

where  $m_i$  is the magnetic dipole moment of the magnet,  $m_c$  that of the coil and  $x$  the distance between both elements. For the determination of the latter, and given the experimental conditions described, the approach has been to consider the distance from the center of the coil to the center of the magnet, in such a way that  $F$  for the position  $x=0.5 \cdot c$  should match the maximum value of the force predicted by expression (3). The accurate determination of the value of the dipole moments would imply a certain theoretical and experimental development [9] that would be

beyond the remit of this study, and for educational purposes it could mask the learning of the central issues that matter here (see [10] for a more detailed and also more complex approach).

The approach used, therefore, is one that is easy for students to understand and that is justified by the results. Both moments were calculated from their respective magnetic fields, measured by the teslameter, and applying the following expressions [7]: a) for the magnet, the field at one of its ends is:

$$B_l = \frac{\mu_0}{2} \frac{m_i}{\pi a^2 \sqrt{a^2 + L^2}} \quad (5)$$

Where  $a$  is the magnet radius (cylinder) and  $L$  its length; and b) for the coil, the field at the centre of its axis can be approximated by:

$$B_c = \frac{\mu_0}{l} N I = \frac{\mu_0 m_c}{\pi c^2 l} \quad (6)$$

where  $c$  is the average radius of the coil, as was formerly explained, and  $l$  its length.

Some other comments to specify these values:

- As seen in the image (Figure 1), the winding had more dense overlapping areas, so an averaged length and radius have been estimated, respectively:  $l = 30$  mm and  $c = 18$  mm. The number  $N$  of the turns of the wire is unknown and not all of them are of the same radius. With respect to the magnet, it consisted of a series of four neodymium cylindrical ones, with the same orientation and coupled together, so the pack forms a cylinder with radius  $a = 6$  mm and length  $L = 40$  mm. Its weight was 0,4 N.

- Current intensity driven along the coil:  $I = 3$  A.

- Magnetic field produced by the magnet. The measured field produced by the described association at its end became  $B_l = 400$  mT.

- Magnetic field produced by the coil: a) with only the PVC pipe:  $B_c = 6.22$  mT.; b) with the copper tube inside:  $B_c = 6.17$  mT.

- Value of the forces needed to remove the magnet from the coil. The maximum

force required to remove the magnet from inside the coil in stable equilibrium position was measured with the dynamometer, both in horizontal and in vertical (in the latter case the weight was obviously subtracted). It resulted to be  $F = 0.6 \text{ N}$ . Moreover, it was proved that its value was the same for the unstable equilibrium position. For this, the maximum force required to make the magnet, with its dipole moment opposite to that of the coil, come through the coil from one end to the other was measured.

As has been stated, a series of measurements were conducted in the General Physics lab with the aim of quantifying the experiment. These are summarized in Table 1.

<i>Coil dimensions</i>	$l = 30 \text{ mm}$	<i>Average values</i>
	$c = 18 \text{ mm}$	
<i>Magnet dimensions</i>	$L = 40 \text{ mm}$	<i>Four linerly coupled Nd cylindrical magnets</i>
	$a = 6 \text{ mm}$	
	$w = 0.4 \text{ N}$	
<i>Coil current intensity</i>	$I = 3 \text{ A}$	<i>Safe range for the employed wire</i>
<i>Magnetic field produced by the coil at its centre point</i>	<i>without copper tube:</i> $B_C = 6.22 \text{ mT}$	<i>Weakness of the copper diamagnetic effect in addition with the small thickness of the tube</i>
	<i>with copper tube:</i> $B_C = 6.17 \text{ mT}$	
<i>Measured maximum force over the magnet</i>	$F = 0.6 \text{ N}$ (horizontal) $F + w = 1.0 \text{ N}$ (vertical)	<i>It fits well with the results of the mathematical expressions for the estimated parameters</i>

**Table 1. Magnitude (left), values (center) and comments (right)**

These measurements made it possible to confirm that the approaches taken in the mathematical expressions given above lead to consistent results between experimental and theoretical values.

### 3. Conclusions

As mentioned above, the realization of this experiment involves a Problem-Based Learning approach that allows us to study some basic electromagnetic concepts: magnetic field and magnetic dipole moment of a coil; magnetic

field and magnetic dipole moment of a magnet; magnetic forces between magnetic dipoles; magnetic potential energy of a dipole in an external field; stable and unstable equilibrium of a magnetic dipole; diamagnetic effect of copper; effect of eddy-current damping or braking.

It is clear that a possible continuation of this work would be a study of the oscillation around the stable equilibrium position, with the magnetic force as recovery force, and this has not been ruled out as a future project. However, a decision was taken not to do so here in order to focus on the analysis of the concepts of equilibrium and stability that, in our view, and as has been explained above, should be well understood by students who are training in electromagnetism at a basic level in a General Physics course.

### 4. References.

- [1] <http://physicslearning2.colorado.edu/pira/> [visited 26-June-2015]
- [2] <http://scitation.aip.org/content/aapt/journal/tpt> [visited 26-June-2015]
- [3] Edelson DC, Gordin DN, Pea RD. Addressing the challenges of inquiry based learning through technology and curriculum design. *Journal of Learning Sciences* 1999; 8: 391-450
- [4] Bisquert J, Hurtado E, Mafé S, Pina J. Oscillations of a dipole in a magnetic field: An experiment. *American Journal of Physics* 1990; 58: 838-843.
- [5] Castañer R, Medina JM, Cuesta-Bolao MJ. The magnetic dipole interaction as measured by spring dynamometers. *American Journal of Physics* 2006; 74: 510-513.
- [6] Donoso G, Ladera CL, Martín P. Damped fall of magnets inside a conducting pipe *American Journal of Physics* 79, 193-200 (2011)
- [7] [http://www.uv.es/martined/tecweb/Dipolos\\_magneticos.pdf](http://www.uv.es/martined/tecweb/Dipolos_magneticos.pdf) [visited 26-June-2015]
- [8] Kraftmakher Y. Magnetic field of a dipole and the dipole–dipole interaction, *European Journal of Physics* 2007; 28: 409–414.

- [9] Bisquert J, Manzanares J, Mafé S. Determinación experimental del momento dipolar magnético: un método estático y dos dinámicos, Revista Española de Física 1992; 6 (1): 43-47.
- [10] Derby N, Olbert S. Cylindrical magnets and ideal solenoids, American Journal of Physics. 2010; 78(3): 229-235



## Developing Environmental Awareness of High School Students: 3rd Enka Ecological Literacy Camp as an Example

*ER Şükrüye*  
*Adapazarı Enka Private High School,*  
*Sakarya, Turkey*  
*ser@enka.k12.tr*

**Abstract.** Natural sources have been used by people because of growing demands. Unfortunately, irreversible mistakes have been made and natural balance has been broken. This is why, nature education is so crucial in developing environmental knowledge and environmental awareness for responsible environmental behaviours. As far as most of the researches are concerned, when the age decreases, students' environmental attitude increases [1, 2]. So early age students' knowledge, attitudes and responsible behaviours can be increased by outdoor activities (greenhouse activities, field trips etc.) [3]

In the project we carried out at Enka School in 2014-2015 academic year, it is aimed at educating young people in order to increase their understanding of ecological sensitivity and develop their positive behaviours towards nature. Since environmental education is an interdisciplinary study, biology and geography teachers at Enka School worked together within the frame of this project. Nineteen high school students from grade 9 to 11 participated to the project between 24-26 April 2015. University collaboration was carried out successfully during the camp activities.

**Keywords.** Ecological literacy, environmental education, nature education

### 1. Introduction

21. century's people have to be the most sensitive against to the nature. Because, need of natural sources is increasing by the increasing human population. Using the sources unconsciously causes chances in the global [4], UNESCO emphasized that the people must have attitudes, behaviors and values of justice for protection the nature [5]. The people' thoughts and behavior patterns or habits cause the basis of the environmental problems.

Environmental behavior is the environment or any natural element directed conscious, planned and intentional activities or actions of human beings or societies [6]. Environmental education helps to people develop their perceptions, sense of responsibility and positive attitudes [1]. So, main aim of natural education is growing the people having environmental responsibility, who inform nature and nature problems, know how solve these problems and volunteere to solve these problems [7]. According to the findings of international works on environmental education, individual can get the environmental education in the secondary education by the most efficiently [8]

Charles E. Roth, defined firstly environmental literacy in 1968, said that environmental literacy is the capacity to show people's informations as behaviours and every one must show steps by order awareness, concern, understanding and behavior, in 1992. On the other hand, outside activities aim on the student;

- To make sense of abstract concepts
- To increase their motivation by improve their curiosity and interest
- To provide students with positive developments in behavioral problems
- To provide a sense of belonging to the community
- To encourage students about experiment and asking questions [2].

### 1.1. Purpose of the study

The purpose of present study is to detect environmental attitudes of high school students within behavioral and mental dimensions and determine the relation of attitudes with respect to several variables. This project aimed also measure the role of ecological literacy education with academic support in raising environmental awareness for students.

### 2. Method

This study was designed as a single group, pre- test and post-test, without control group design, experiment research pattern. Duration of our project, nineteen participant high school students (9th, 10th and 11th grade attending



from two different schools) including 8 females and 11 males, and three observer teachers, stayed at boarding accommodation within the school campus.

A three-day work calendar was determined for camp. First day activities were meeting and settling of students and night activities. The main aim of our study to answer research questions was carried out mostly second day. Because really important scientist gave presentations, themes were determined by academics. The last day, supporting field work was undertaken which academics deemed relevant to the project.

### 3. Result and discussion

Modern constructivism and Dewey define teaching has to be anchored to the everyday life of the students. We realized that environmental education issues are only theoretical in our geography and biology curriculum [9]. On the other hand, scouting, which involves both value education and reflective thinking, is one way of learning about nature *in nature* and developing action skills to protect nature [3]. In our project, students' gain score on behavior item from posttest were significantly higher than that from pretest. This refers that ecology based nature education program significantly contributed to the development of responsible environmental behavior.

Natural education and application in natural areas help to embody of topics which tell in the classroom [1]. We aimed with our project that environmentalism as a life style as a continuation of 1.Ecological Literacy Camp in our school in 2012 [10]. Our participants are twenty one high school students. The important matters to address are students' feelings of being capable of doing something important in order to nature. scouting the nature by fearless and also funning. Experiences in outdoor activities developed strong empathic relationship to nature. The first and main feedback of students was understanding the colours of natures. They recognized animals in nature by touching them, flora- fauna, coastal withdrawal and people effects, aquatic ecosystems and environmental management by connecting basic units of biology and geograpy. This project created awareness in young people of the deteriorating environment and educated them to prevent further damage.

1. Day: 24.04.2015-Friday	
17.00-18.00	Student Orientation and Settle in Room
18.00-20.00	Dinner
20.00-22.45	Outdoor Cinema, <i>The Way Back</i>
2. Day: 25.04.2015-Saturday	
07.30-08.15	Breakfast
08.15 – 08.45	Registration, Pre- Test Application
08-45 – 09.00	Opening
09.00 – 11.00	Prof. Dr. Ali Demirsoy, “ <i>Danse of the Colors</i> ”
11.00-11.30	Break
11.30-12.30	Assistant Professor Dr. Mahnaz Gümrükçüoğlu, “ <i>The Smart Land and Recourseful Water</i> ”
12.30-13.30	Lunch Break
13.30-14.30	Dr. Hakan Durmuş, “ <i>Mysterious World of Amphibians and Reptiles</i> ”
14.30-15.00	Break
15.00-16.00	Assistant Professor Dr. Muhammet Kaçmaz “ <i>Water and Human</i> ”
16.00 – 19.00	Free Time
19.00 – 20.00	Dinner
20.00 – 22.30	Sapanca Lake Trip
22.30 - 23.00	Arrival to School
3. Day 26.04.2015-Sunday	
07.30-08.30	Breakfast
08.30-09.00	Movement to Poyrazlar Lake
08.30-12.30	Poyrazlar Lake Field Work
12.30-13.00	Lunch Break
13.00-13.30	Movement to Karasu
13.00-15.30	Karasu Port Field Work
15.30-16.30	Movement to School
16.30-17.00	Last Test Application
17.00-17.30	Giving of certificates to the participants and Closing

Table 1. ENKA Ecological Literacy Camp Day-time Activities



Activities	Activity Name( Night Time)
1.	Outdoor Cinema
2.	Discovery of Sapanca Lake

**Table 2. ENKA Ecological Literacy Camp- Night Activities**

Test	n	Min- Max	Average	SS
Pretest	21	0- 84	58	6,66
posttest	21	0- 84	67	3,74

**Table 3. Pretest Posttest Comparisons**

## Acknowledgement

Authers thank to the retired Prof. Dr. Ali Demirsoy from Hacettepe University and his beautiful wife Funda Demirsoy from Ankara University, Assistant Professor Dr. Mahnaz Gümrükçüoğlu and Assistant Professor Dr. Muhammet Kaçmaz from Sakarya University, Dr. Hakan Durmuş from Dokuz Eylül University and my partner Ömer Yıldırım from Enka Private High School geograpy teacher for their support and help for this project.

## References

- [1] Erdoğan M. The Effects of Ecology-Based Summer Nature Education Program on Primary School Students' Environmental Knowledge, Environmental Affect and Responsible Environmental Behavior. *Educational Sciences: Theory & Practice* - 11(4); 2011.
- [2] Erentay N, Erdoğan M. 22 adımda doğa eğitimi. Odtü Yayıncılık: Ankara; 2009.
- [3] Palmer IE Kuru J. Outdoor activities as a basis for environmental responsibility. *Journal of Environmental Education*, 31 (4), 32-37; 2000.
- [4] Gökdağ D. Ortaöğretim programında çevre. *Cogito*, 2, 47-50; 1994.
- [5] UNESCO, the Tbilisi Declaration: Final Report Intergovernmental Conference on Environmental Education. Organized by UNESCO in Corporation with UNEP, [www.gdrc.org/uem/ee/EE-Tbilisi\\_1977.pdf](http://www.gdrc.org/uem/ee/EE-Tbilisi_1977.pdf); 1978.
- [6] Uzun N. Ortaöğretim öğrencilerinin çevreye

yönelik bilgi ve tutumları üzerine bir çalışma. Hacettepe Üniversitesi. Ortaöğretim Fen ve Matematik Alanları, Anabilim Dalı, doktora tezi, Ankara; 2007.

- [7] Kışoğlu M, Gürbüz H, Sülün A, Alaş A, Erkol M. Çevre Okuryazarlığı ve Çevre Okuryazarlığı ile İlgili Türkiye' de Yapılan Çalışmaların Değerlendirilmesi. *International Online Journal of Educational Science*, 2 (3), 777-791; 2010.
- [8] Ünal S, Dımişki E. UNESCO UNEP himayesinde çevre eğitiminin gelişimi ve Türkiye' de ortaöğretim çevre eğitimi. *Hacettepe Üniversitesi Eğitim Fakültesi Dergisi*, 16-17, 142 – 154;1999.
- [9] Biology and geograpy curriculum, <http://ttkb.meb.gov.tr/program2.aspx>
- [10] Ertekin T, Yüksel Ç. The role of ecological literacy education with academic support in raising environmental awareness for high school students: " Enka ecological literacy summer camp project case study". *Procedia- Social and Behavioral Sciences* 103, 124-132; 2014.

## Learning to Be Critical with Mathematics: Body Mass Index

S Abreu<sup>1</sup>, E Fernandes<sup>2</sup>

<sup>1</sup>Middle School Prof. Dr. Eduardo Brazão de Castro, Portugal

<sup>2</sup>University of Madeira; Portugal  
soniaabreu@live.madeira-edu.pt,  
elsa@uma.pt

**Abstract.** This paper presents part of an investigation from the first author's master, whose aim was to discuss how Critical Mathematics Education in school contributes to the formation of critical and responsible citizens. The empirical basis of this study consisted in the implementation of a learning scenario which purpose was to work with students the critical analysis of some news in newspapers and magazines, whose topics were focused on Body Mass Index. Given the stated purpose of the study, we choose a qualitative research methodology with interpretative nature.

**Keywords.** Critical Mathematics Education, Critical Citizens.

### 1. Introduction

The school should provide a social environment where students learn to live in society, by living. The responsibility of educating for citizenship should not be just a task of a specific school discipline, but from all those who are part of the school community [1].

If we want to promote and enrich the development of critical thinking in our students, therefore we must not explore problems based on 'realities of make-believe' that are illustrating mathematics as the science of hypothetical situations. But instead, if we choose real situations, connected with students' daily life and related with students' background and foreground, we will be certainly allowing their engagement during classes [2].

Therefore, it is necessary to make time for dialogue in the classroom, sharing opinions and discussing the topics presented in class. Only this way we will be able to avoid the students to become passive and indifferent, even the most curious, accepting all the information they are presented everyday without questioning.

We believe the students will only and truly understand how the mathematical models that explain politics, economics, science and others work, if instead of adjusting real situations to the mathematical contents, we start by analysing those situations and from that analysis identify which mathematical contents support them.

The learning scenario was created to be implemented with an 8<sup>th</sup> grade class, from a school in the suburbs of Funchal. 'Extreme thinness' was the theme of the learning scenario and it was prepared based on a magazine article, describing the low weight of some celebrities. The analysis of the magazine article encouraged students to explore the concept of Body Mass Index (BMI). In attempting to understand what relationship existed between height and weight to calculate BMI, students had a first contact with the literal equations. This mathematical content appears in a natural way, where the variables have a specific meaning, that is, not only a set of 'alphabet letters' and symbols related to each other.

The focus of this approach was not restricted to BMI calculation. Through the questions asked to students, we also tried to address diseases related with eating disorders that manifest themselves with some frequency on teenagers. We also end out discussing with students the power of media and how it affects students' opinions on various subjects.

### 2. Learning through Critical Mathematics Education

"Certain qualities of communication, which we try to express in terms of dialogue, support certain qualities in learning of mathematics, which we refer to as critical learning of mathematics manifested by the competence of mathemacy" ([3], p. 10).

This learning approach for mathematics is based on communication and discusses that communication qualities are learning qualities. The student/teacher relationship influences the dialogue and, therefore, the learning process of the students. In this perspective, communicating comprises a deeper meaning than the common sense [3]. The learning process occurs in social contexts of interpersonal relationships. The quality of communication affects the learning of those

involved in the process. And the communication is directly related with the dialogue [3].

The student/teacher relationship might influence the dialogue and therefore the learning process of the students. According to Freire in Alro and Skovsmose [3], “dialogue is fundamental for freedom to learn. [...] He defines dialogue as a meeting between people in order to ‘name to the world’” (p. 3).

We will contribute for the students’ engagement during the activities developed in class through dialogue and the choice of tasks that are interesting to the students, adequate for their age, social context, related to their ‘background’ (according to Skovsmose [4], it consists in a relationship network and socially built meanings, which belong to the history of each individual) and ‘foreground’ (according to Skovsmose [4], it consists in a group of expectations created by social situations that are introduced to the individual as possibilities). This way the students will be more awake to analyse and identify daily situations where mathematics is used abusively and in a misleading manner, with the intent of manipulating information and deceive the less attentive, or when it appears hidden and using more complex mathematic models.

By critically approaching the Mathematics Education, we are contributing to the development of ‘mathemacy’, which according to Alro and Skovsmose it is “more than an understanding of numbers and figures, also more than an ability to apply numbers and figures to a variety of situations” ([3], p.136).

In the Critical Mathematics Education, the education is focused on people and it “(...) prepares the students for democracy, whereas the traditional mode socializes the students to obey power and control” (Rogers in Alro and Skovsmose ([3], p. 4).

### **3. Methodology**

The present investigation assumes a qualitative nature with an interpretative character, and its main purpose is to better understand the behaviour and the human experience, as Bogdan and Biklen [5] mentioned.

This type of methodology assumes a

naturalistic and descriptive nature about the empirical observation of the students’ behaviour, in light of specific situations, namely during tasks that involve critical thinking.

The data collection was conducted in an 8<sup>th</sup> grade class in a school located in the suburbs of Funchal.

In terms of the methodology used, direct observation should be highlighted. It played a very important role, as it allowed understanding in which way the students face the proposed situations and tasks and what is their opinion on the issues discussed in them.

In this sense, the teacher walked through the classroom and dialogued with the students, while informally registered the most relevant comments and observations. The students were quite honest and spontaneous in their interventions, as the investigator is the mathematics teacher of the class, which created a confidant environment.

After solving the tasks proposed, the teacher collected the written documents produced by the students, in order to allow a more detailed analysis of the presented opinions and explanations.

### **4. Body Mass Index**

The Body Mass Index theme arose in an attempt of raising awareness of the complications that can come from a poorly balanced diet and/or not adequate to their physical needs. Therefore, the purpose was not only to raise awareness of the diseases affecting young teenagers – anorexia/obesity – but also to approach certain mathematical contents. In this specific case, we wanted the students to be able to distinguish ‘algebraic expression’ from ‘formula’ and to identify them in a real context.

In this sense, the students started reading a news article called “Extreme Thinness”, available at <http://caras.sapo.pt/realeza/inglaterra/2011/08/14/magreza-extrema-da-princesa-kate-podera-impedi-la-de-engravidar>. This article refers to Kate Middleton and the fact that her weight is below the acceptable level of thinness. It also mentions that this state is very dangerous for a woman who is trying to conceive and assure the next generation of the British royal family.

The magazine article also states that infertility is one of the consequences of low weight, and for that reason Kate Middleton has to revert this trend of losing weight, which started before her marriage. The article still includes her weight (43kg), her height (1,78m) and her BMI (13,6), so that the readers can better comprehend the situation.

After reading the news, the students asked several questions to the teacher, showing evidence of their lack of knowledge on the subject, as well the will of knowing more about it. This way, the teacher dialogued with the students, questioning them not only about the meaning of the relationship between the BMI and the height of an individual, but also when those values are normal, and the implications when that relationship is not adequate.

The teacher created a task with various questions [6], in order to facilitate the analysis of the news. The first question suggested that the students searched on the Internet how to determine the BMI and its reference values. There was a notorious interest and enthusiasm during this process. The search resulted in several pages where it was only necessary to insert the height (in meters) and the weight (in kilograms) in order to obtain the BMI.

The students easily understood that was not enough to answer to the second question, which consisted in determining the weight range for Princess Kate, so that she would have a normal level of BMI.

Therefore, the necessity of searching for a mathematical model that allowed to calculate the BMI arose.

After finding the formula, the students tried to determine the range asked. Although they had used other mathematic formulas in other contexts, the students had difficulties in answering the question using the formula. In other words, they struggled when they tried to relate the formula with the apparent non-mathematical question. The teacher had to pose several questions as an incentive to the students, so that they would keep trying to complete the task.

The third question provided information about the weight and BMI of another member of a European royal figure and asked the students to calculate the height of

that individual. While solving this question, the students showed more confidence and ease using the BMI formula.

The last question of the first task consisted in commenting a sentence from a British duchess: "a woman is never ... too thin". Some students found the question very pertinent, some found it not related with mathematics.

It is not natural for the students to search about issues that they read or to use previous acquired knowledge to better understand economic, social and political aspects. This attitude might also be related to the fact that the school does not enhance this habit, especially in the context of a Mathematics class.

During the discussion of the last question, the concern and awareness raised in some of the students was visible, in what concerns the power of social media and its influence in the way young people think. They recognised they are not used to question the content of the information they read in the media, assuming it is the truth. Through dialogue, the teacher was able to make the students reflect about a statement, using mathematics.

In the second task it was discussed what was necessary in order to have a healthy life. It was concluded that it would be necessary to keep the weight within the normal level, be physically active, and follow a healthy diet. Besides the quality of the diet, it would be also necessary to know the energetic needs of each individual.

Afterwards, the students were asked to calculate their energetic needs. For that purpose, they used a formula provided for the task, in which they had to take into account their reference weight and their current activity factor.

By solving this task, the students understood that the energetic needs vary and are directly related to gender, age, height and activity factor.

After the discussion of this task, the students showed curiosity in searching the calories contained in the food they usually eat. They were quite surprised with the amount of

calories in a fast food meal. For some, it corresponded to the energetic needs of an entire day.

All this work resulted in the students mentioning that they had no idea that a field like nutrition had such a need for the use of formulas. Some even reinforced the fact that “mathematics is present everywhere” and for that reason it was very important to analyse, comprehend and criticise the mathematical models adopted by society.

## 5. Conclusions

In the past decades, there have been several technological advancements, which allowed for social, political, cultural and economic transformations. This modification has introduced a new challenge for Mathematics Education – to make the students mathematically competent, so that they can understand these hidden mathematical models in daily situations. For that reason, the Critical Mathematics Education was taken into the mathematics classroom.

The tasks proposed and the work methodology adopted in this learning scenario allowed for dialogue to enhance the fundamental characteristics to the critical learning of Mathematics. When the students were discussing the issues mentioned in the news, they would present their justifications based on mathematical concepts, even if they did not understand all the mathematical aspects of the news. Therefore, the mathematical contents approached arouse from the dialogue, the past experiences of the students and the previous acquired knowledge. They arouse naturally, even though the teacher had the intent of approaching those specific contents.

From the data analysis we can highlight the importance of the tasks covered by the students being related with real situations and somehow linked to the students’ backgrounds and foregrounds, for the purpose of triggering in them the intention to learn.

We can also say that with this learning scenario students have been working at the level of critical thinking development and social responsibility using mathematics.

## 6. References

- [1] Fonseca A. Educar Para a Cidadania: Motivações, Princípios e Metodologias. Porto: Porto Editora; 2000.
- [2] Skovsmose O. Educação Matemática Crítica: A Questão da Democracia. São Paulo: Papyrus Editora; 2001.
- [3] Alro H, Skovsmose O. Dialogue and Learning in Mathematics Education - Intention, Reflection, Critique. Dordrecht: Kluwer Academic Publishers; 2004.
- [4] Skovsmose O. Towards A Philosophy Of Critical Mathematics Education. Dordrecht: Kluwer Academics Publishers; 1994.
- [5] Bogdan R, Biklen S. Investigação Qualitativa em Educação: Uma Introdução à Teoria e aos Métodos. Porto: Porto Editora; 1994.
- [6] Abreu S. Educação Matemática Crítica: O seu contributo na formação de cidadãos críticos e responsáveis. Relatório da Prática de Ensino Supervisionada; 2012. <http://repositorio.uma.pt/bitstream/10400.13/482/1/MestradoS%C3%B3niaAbreu.pdf> [visited 12-Jun-2015].



## Discovering Light. The 5th Science Fair Hands-on Science

*MFM Costa, Z Esteves*  
*Universidade do Minho, Portugal*  
*mfcosta@fisica.uminho.pt,*  
*zita.esteves@gmail.com*

**Abstract.** Inscribed in the celebrations of the International Year of Light, IYL2015, in Portugal, the Hands-on Science Network Association together with the Portuguese Society of Optics and Photonics15, SPOF, and with the support of the European Physical Society, organised the 5<sup>th</sup> Science Fair Hands-on Science this year under the main theme "DISCOVERING LIGHT".

The competition was open to students and groups of students, but also teachers and educators of all levels of education, from pre-primary to higher education and to anyone interested on science and science education. Over hundred contributions were considered of all kinds, from hands-on experiments to experimental demonstrations, posters and lectures but also dance and drama performances as well as other artistic expressions such as drawings, poems, and even songs... all vivid expression of a fertile imagination creativity and ingenuity with a true and sound interest of the participants on science and specially on light optics and its applications.

Themes were the most varied, not only related to the physical properties of light and its multiple applications or to the different and extraordinary optical phenomena or optical instruments that make our lives easier and more interesting and which are so important for the development of our societies, but also those in the fields of dream and "magic" ... connecting in fact all dimensions of the human being in most interesting and pleasant ways.

The science fair held in Viana do Castelo, northwest of Portugal, May 25, 2015, enrolled over five hundred participants and a few hundred visitors in an exciting and most lively and enjoyable day that surely contributed significantly to raise the awareness of the importance and appeal of Optics and Photonics.

**Keywords.** IYL2015, Light, Optics, Science Fair, Hands-on Science

### 1. Introduction

Science fairs are currently recognized as important activities in science education by numerous skills that they can develop in students because they should behave as investigators/researchers when developing their project. Students should define and understand the nature of the problem that they have to solve [1]. Students will gain the ability to solve problems, since they need to make decisions and create alternative hypotheses. On the other hand they develop creativity and imagination [1].

The informal environment of a science fair competition process allow the students to develop skills that make possible to them to establish a relationship between cognitive, affective and social knowledge [2].

The active involvement of students in their learning process through this kind of hands-on activities is one of the most effective methods to engage students on science learning [3].

Previous editions of the "Hands-on Science" science fair showed the enthusiasm and commitment of the students and illustrated the aforementioned benefits of science fair for the students, their teachers and schools [4,5,6].

2015 was designated by UNESCO "The International Year of Light " in recognition of the importance of light and technologies related to light in promoting sustainable development and the search for solutions to global societal challenges in the fields of energy, education, agriculture and health, and in all fields of industry an human life. Being optics one of the key development enabling domains of science it was decided to set light as the main theme of the 5<sup>th</sup> edition of the HSCI science fair.

### 2. Organization

The Hands-on Science science fair already in the fifth edition set a well established reputation among schools and educational institutions in Portugal. This year it was set as a special edition dedicated to IYL2015, the International Year of light, and was organized together with the Portuguese Society of Optics and Photonics, SPOF, and endorsed by the



European Physical Society.

As in previous years advertising the initiative was done through the web pages created for this purpose ([www.optica.pt/iyl2015](http://www.optica.pt/iyl2015)) and through e-mailing sent to former participants and to schools all over the country. It was also extensively advertised among to the members of HSCI and SPOF and by the European Physical Society and through the website of the International Year of Light ([www.light2015.org](http://www.light2015.org)). Several Portuguese universities (the universities of Minho, Porto, Aveiro, Beira Interior, Madeira and Algarve) and the Erentay Egitim Danismanlik (<http://www.erentayegitim.com/>) were also actively involved in the process.

This good dissemination the remarkable attraction to this subject but also an extension of the age range open to participation (in previous years it was only open to the participation of students aged between 10 and 18 years old but in this edition it was open from 4 year olds to adults) led to an increase on the number of participants surpassing five hundred.

The event was announced at the beginning of the school year in September. Participants had until the beginning of the month of April to sign up. To participate the teams (group, individual or institutional) had to fill a form with some relevant information about their project and team. With this information the organizing committee divided the projects by categories and began preparing the competition. The projects that were not directly related with the main theme of fair, the light, but who respected the general rules of the science fair were accepted 5<sup>th</sup> edition to specific categories set as regular science fair.

At the beginning of the month of May, each group had to confirm their participation and upload to the competition website ([www.optica.pt/iyl2015](http://www.optica.pt/iyl2015)) and abstract and all relevant material concerning the work to be presented at the science fair to be held in the premises of the Colégio do Minho school in Viana do Castelo, May 25, 2015. All submitted material remains accessible on the website for consultation. Other important information such as arrival time, water and electric current need, number of tables necessary to their presentation, multimedia, poster stands, etc... Given the particular theme of this year's science fair, light, a main concern was the

availability of darkened spaces for the presentations.

To meet the needs of all participants we organized different spaces: a gym, a place outdoors but protected from the sun, two dark rooms and a large stage, also darkened.

As always the science fair was open for visit and participation of other students the local community and general public. Several schools made the request for the visit and these early appointments facilitated the organization the event and guarantee a smooth development of the fair in spite the over one thousand, enthusiastic participants.

On the science fair day, in order to help in the organization process thirty high school students of the *Colégio do Minho* were enrolled as organization staff. The function of these students was to help in the organization of the space, welcoming and assistance to participants and visitors. Not only their work and efforts were fundamental to the success of the fair as they greatly and proudly enjoy it.

### 3. Participants

The participants of the 5<sup>th</sup> Hands-on Science science fair were divided in two main large groups: of projects related with light and projects with other themes (mainly environment related).

The two large groups were also subdivided by categories, based on their ages. Therefore, projects related with light were divided in 5 levels:

Level A – students from pre -school to 1<sup>st</sup> cycle (4 to 8 years old)

Level B - students from 2<sup>nd</sup> and 3<sup>rd</sup> cycles (9 to 14 years old)

Level C - students in secondary schools and vocational education (15 to 18 years old).

Level D - university students, teachers and educators, or other adults.

Level E - Schools, or other institutions.

The distribution of the hundred projects accepted for the “Discovering Light” science fair competition by category is shown on Figure 1. There were projects from all levels. However

the stronger group came to basic/primary school level. To notice the not so usual involvement of adults and institutions. More than a typical science fair (and the HSCI' science fair have a particular twist on the focus given to the investigative hands-on process of the preparation of the projects and the open informal and friendly interactive atmosphere of the fair that we actually called "Festa" – that is "party" in Portuguese...)

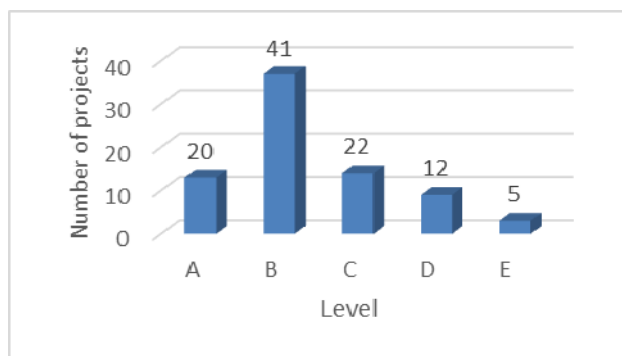

Figure 1. Distribution of projects on the light subject

A few projects that were accepted did not participate at the "Festa da Luz" essentially due either to lack of time to finish their projects or to the impossibility to travel to Viana do Castelo.

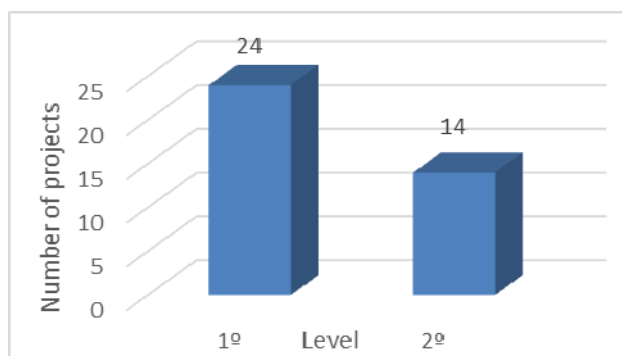

Figure 2. Number of projects not related with light

The projects with topics unrelated to light were about 70 including 30 posters brought from Turkey' project "S.O.S., Saving Our Species". Since there were in lower number, they were divided in only two groups, as can be seen in Figure 2:

1<sup>st</sup> level – students from 2<sup>nd</sup> and 3<sup>rd</sup> cycles (ages between 10 and 15 years old);

2<sup>nd</sup> level – students from secondary school or university (15 to 22 years old).

In both cases, the larger participation lied with students from 10 to 18 years old.

The projects could address any area of knowledge and have different forms of presentation. Only on the subject of light we had the participation of younger students and also of teachers and institutions.

The majority of participants came from Portugal as it was initially intended. However the "Discovering Light" science fair raise interest in other countries. A large delegation of 41 participants from Turkey brought to Viana do Castelo lots of enthusiasm and 37 interesting projects of different types from hands-on demonstrations, exhibitions, boots, posters, as well as music and dance celebrating light with lots of creativity.

#### 4. Brief overview of the projects

It was allowed to submit projects of a wide variety of kinds ([www.optica.pt/iyl2015](http://www.optica.pt/iyl2015)) to be presented in a wide variety of forms: from hands-on experiments and demonstrations, boots, exhibitions, posters or oral presentations, paintings or sculpture, drama and performances including music and dance.

Thus, there was an in fact high diversity of themes and types of presentations.

Some of the projects were presented in an expositive way, through posters, multimedia presentations or models. As an example we have the "Sustainable Eco City" with a model of a city where recycling is favored and renewable energy is used, such as wind power and solar energy, as it can be seen on Figure 3.

Some projects were more interactive allowing the visitors interact with the projects, as the one in Figure 4.

Other projects have shown to be more artistic, as seen in

Figure 5, where a group of five years old students, dance to the sound of music, accompanied by a robot they built and programmed. Based on the theme of light, the dark stage, the light combinations and the student's clothes performed a show that earned them the 3<sup>rd</sup> prize in category A.

Younger visitors were in focus several times throughout the afternoon. A moment just for

them was provided by the project "A story with Science" (

Figure 6) which consisted on a story read to them from which they participated and various everyday situations were explained to them through physical and biological phenomenon related to light.



**Figure 3. "Eco Sustainable City" - Honorable Mention of the 1st category of projects unrelated to light**



**Figure 4. Visitor experimenting one project related with light**



**Figure 5. Project the "Magic and Light"**



**Figure 6. "Story with science" for students under 10 years old**

#### **4.1 The "winners"**

Of course prizes were a small part of all science fair contest. However the effort of all had to be recognized and lots of very interesting project were presented to the evaluators. Given the large number of projects involved we set up different groups of judges according to the contest level.

To evaluate the projects, some parameters were set to be taken into special account:

- Originality of ideas and projects and their implementation;
- Creativity;
- Innovation;
- Experimental and scientific rigor.
- Broad knowledge of the subject;
- Safety Precautions;
- Scientific-technical or artistic quality and presentation;
- Aesthetic quality of the presentation;
- Interdisciplinary / mainstreaming;
- Involvement of colleagues, family and / or community;
- Interaction with visitors and other participants.

For the task of evaluating, we created groups of juries with 2 or 3 members, where the majority was specialist on the scientific subject of the project. Three group evaluated one

category.

The evaluation process was divided into two parts: the analysis of the projects description that each group submitted when they made the application and its presentation on the science fair day. At the science fair each group of jury members evaluated the presentation of the respective projects in order to give the final classification. Some of the reviews coincided with the previous evaluation performed by the description, but in some cases, oral presentations made the difference.

All students that participated and responsible teachers involved received certificates of participation and a t-shirt of souvenir. At the end of the day, awards and honorable mentions were given in each of the categories.

## 5. Conclusions

As in previous editions, the 5<sup>th</sup> Science Fair Hands-on Science “Discovering Light” transpired in a very positive way both to participants visitors and organizers. This year’s science fair had a much higher dimension than previous editions which required a larger team for the organization and heavier organizational structure. However the open mind friendly and informal spirit typical of HSCI organizations greatly facilitated the task.

Projects were presented by participants from all ages starting from 4 years old children up to adults, with a wide range of presentations types. Everybody respected and enjoyed each other with a truly *feira* (party) celebration atmosphere.

The celebration of the international year of light seems to have been a great incentive for participation in this kind this activity.

All participants stated the enjoyed to develop and present their projects and everybody could learn a bit (a lot...) more about science wanting to repeat the experience!.

## 6. References

- [1] Bencze, JL, Bowen GM. A National Science Fair: Exhibiting support for the knowledge economy. *International Journal of Science Education*; 31(18); 2009.
- [2] Hodson D. “Time for action: science

education for an alternative future,” *International Journal of Science Education*, vol. 25, no. 6, p. 645-670; 2003.

- [3] Robertson BQ. “How can hands-on science teach long-lasting understanding?” *Science and Children*, pp. 52-53, 2000.
  - [4] Esteves Z, Costa MFM. 1st Hands-on Science Science Fair”. *Proceedings of the 1th International Conference on Hands-on Science*, Ljubljana, Slovenia; 2011.
  - [5] Esteves Z, Costa MFM. 2<sup>nd</sup> Portuguese Science Fair “Hands-on Science”. *Proceedings of the 9<sup>th</sup> International Conference on Hands-on Science*, Antalya, Turkey; 2012.
  - [6] Esteves Z, Costa MFM. Statistical Analysis on Three Hands-on Science National Science Fairs in Portugal. *Proceedings of the 10th International Conference on Hands-on Science*; Kosice, Slovakia;2013.
- 
-

## The Euro4Science Forensic Science Education Toolbox – Demonstration of Beta Version

*L Souto, F Tavares, H Moreira,  
R Fidalgo, R Pinho  
University of Aveiro, Portugal  
lsouto@ua.pt*

**Abstract.** In the frame of the Euro4Science project, a strategic partnership that explores the potential of the “CSI effect” in education, an Educational Kit is conceived proposing a series of attractive experimental activities which include main topics such as Biology and Biodiversity, Toxicology, Human Individual Identification and Bioinformatics.

The Forensic Science Education Toolbox is expected to be used by students under teachers’ supervision. Students will find different materials that will enable several experiments applying forensic science methods adapted to basic and high school context and school curricula, following a Student’s Guide of Exploration, based in forensic cases. Teachers will be able to educate and inspire the students in the principles of scientific inquiry, analysis and creative thinking.

The Forensic Science Toolbox educational kit is subjected to previous testing, starting from university labs (conception, planning and adjustments) and continuing through teacher’s practical evaluation and finally by students in school context.

The HSCI meeting is an occasion of demonstrating this educational proposal and sharing ideas and contributions from teachers and colleagues of different countries which meet the Euro4Science project features – hands on experiences and different cultural and challenge pedagogical environments while promoting students and teachers cultural exchange.

**Keywords.** Euro4Science, Toolbox.

### 1. Introduction

According to the European Commission, around six million young people drop out of school each year. This phenomenon brings expensive costs to economic growth and competitiveness and negative consequences to

individuals [1].

The Euro4Science project is a Strategic Partnership that will use the potential of the “CSI effect” (that is the popularity of “crime scene TV series” and its influence) in schools to address difficulties (e.g. school dropout, low interest in STEM - science, technology, engineering, and mathematics) and challenges identified in European school systems [2].

The Euro4Science project includes developing, testing and implementing a Forensic Science Education Toolbox in 4 languages (English, Portuguese, Bulgarian and Polish) to be used in European Schools and later disseminated beyond participating partners/countries.

### 2. Forensic Science Education Toolbox

The Forensic Science Toolbox is a physical educational kit box designed and produced to be used by students under teachers’ supervision. Students will find different materials/kits that will enable several experiments applying forensic science methods adapted to basic and high school context.

It will consist of a main box with materials and several support documents:

- Box: This “mysterious” box will be opened by the investigative methods of science (cross reference with the Scientific Method). It contains materials enabling the simulation of crime scene analysis techniques to be used in a pedagogical and scientific base in the classroom. All materials of the Toolbox are expected to be applied under safe and environmental friendly procedures.
- Students Guide: This working manual of exploration of activities includes guidelines for the use of the materials in a classroom context and activities that can be carried out at home safely by the students. These activities will be associated to learning contents and questions addressing scientific concepts adequate to each education level.
- Teachers Guide: this manual includes detailed guidelines for the use of the Toolbox in a classroom context (specific lessons will be proposed conciliating different activities, with the possibility of shortening or widening the length and level of the lesson).



Guidelines and list of materials for teachers and students to build a toolbox by themselves, e.g. with the collaboration of teachers/students of different areas are also provided so promoting dissemination and networking.

- CSI Cases: These cases consist of suggestions of how to integrate skills around a theme, using problem/mystery solving and discuss sociological implications with students [3].

### 3. Proposed activities for the Classroom

The Euro4Science Project suggests strategies for planning, development and implementation of simple activities in the classroom, based on Forensic Science methods. The proposed activities were planned to integrate several relevant contents educational science curricula (mainly secondary but also basic levels) and explore topics from Biology (DNA, cell and tissues, blood groups, immunity) to Chemistry and Physics with potential intersections with Social Sciences and Languages and Literature. The majority of materials used in these activities are low cost, eco-friendly and safe.

#### 3.1. Fingerprints

Fingerprints were a major breakthrough in forensic science and it gave law enforcement around the world a new tool to help in the investigation of a crime. Fingerprints have unique individual characteristics that can be used to identify a specific individual. From the different types of fingerprints that can be found, the most common are latent fingerprints [4].

##### 3.1.1. Activity 1 – Dusting and Lifting Latent Fingerprints

This activity aims to develop the students' understanding how graphite powder can be used as an alternative to commercial powders to reveal fingerprints (Fig. 1). It is important that students realise that fingerprints are deposited on the objects due to the transfer of natural secretions of sweat, which is a combination of water, oils and salts, produced by glands. When the graphite powder is applied to the area that contains the latent fingerprint, the powder adheres to the residues that make up the fingerprint.

Students should compare the results obtained with the fingerprints presented in the case study and share their interpretations of results and conclusions.



Figure 1. Revealing latent fingerprints using graphite powder



Figure 2. Revealing latent fingerprints using superglue fuming

##### 3.1.2. Activity 2 – Revealing Latent Fingerprints using Superglue Fuming

The purpose of this activity is to reveal latent fingerprints using a chemical reagent that is commonly found in our homes, the superglue. The primary component of superglue is the cyanoacrylate. Cyanoacrylate fuming or Superglue fuming is a physical process. Cyanoacrylate vapour is selectively attracted to fingerprint residues, where it builds up as a crystalline white deposit (Fig. 2). It will be important for students to understand the mechanisms of the superglue fuming. The superglue fumes are catalysed by tiny amount



of moisture attracted by the sodium chloride residues in latent fingerprints.

Students should compare the results obtained with the fingerprints presented in the case study and share their interpretations of results and conclusions.

### 3.1.3. Activity 3 – Revealing Latent Fingerprints using Iodine Fuming

This activity reveals latent fingerprints using iodine.

The iodine fuming method uses iodine crystals that vaporise by sublimation when heated (Fig. 3).



**Figure 3. Revealing latent fingerprints using iodine fuming**

It is important that the sublimation process is understood by students and that the violet iodine vapour adheres selectively to fingerprint residues, turning them orange. These orange stains are reversible.

Students should compare the results obtained with the fingerprints presented in the case study and share their interpretations of results and conclusions.

## 3.2. DNA Profiling

Except for identical twins, human DNA profiles are unique.

DNA analysis is based on the fact that every living is composed of cells, all of which contain DNA in some form [5]. DNA evidence from a crime scene or from an unidentified body can be traced back to a crime or eliminate a suspect.

Forensic DNA profiling is a technique employed by forensic scientists to identify individuals by their DNA [4] [5].

The activity proposed is DNA analysis

technique by gel electrophoresis using simple and home-made materials.

### 3.2.1. Activity 4 – DNA profiling – Electrophoresis

This activity aims to develop the students' understanding how to compare DNA profiles and conclude by excluding or including a given suspect or an alleged father in a paternity test using electrophoresis as separation method (polymer, ions, buffers, electrical intensity and power, also may be explored). Gel electrophoresis is used to separate different compounds from a mixture. With DNA gel electrophoresis, the goal is to separate DNA fragments based on different sizes and masses. Forensic labs, as multiple biomedical labs, use polymers such as acrylamide and agarose gel and commercial buffers to perform an electrophoresis.

In this activity we use everyday cooking products to replace these reagents. Corn starch replaces the acrylamide/agarose polymers and kitchen sodium bicarbonate replaces sophisticated analytical grade composition buffers (Fig. 4).



**Figure 4. Corn starch gel**

A typical electrophoresis apparatus consist of a gel chamber surrounding by a buffer chamber, with provisions for connecting electrodes at opposite ends. To form the wells in the gel is used a comb suspended in the gel chamber. In this Forensic Toolbox activity we replace this electrophoresis apparatus with easy access materials. For make the comb we use a regular shampoo package, for the gel chamber we use a butter container and for the buffer chamber we use a regular plastic container (Fig. 5).

In these work we use copper electrodes, since the cooper is a good conductor of electricity allowing the passage of current (Fig. 5).



Figure 5. Electrophoresis apparatus

Regarding to the power supply, the professional gel electrophoresis apparatuses use expensive DC power supplies that can be adjusted over a wide range of voltages. For the home gel electrophoresis, we use as alternative power source 9V transistor batteries wired in series (Fig. 6). The samples used to simulate human DNA were food dyes.

In this activity it is important that the students understand the importance of the electrophoresis and chemical reactions behind the electrophoretic process. Students should compare and discuss the results obtained.

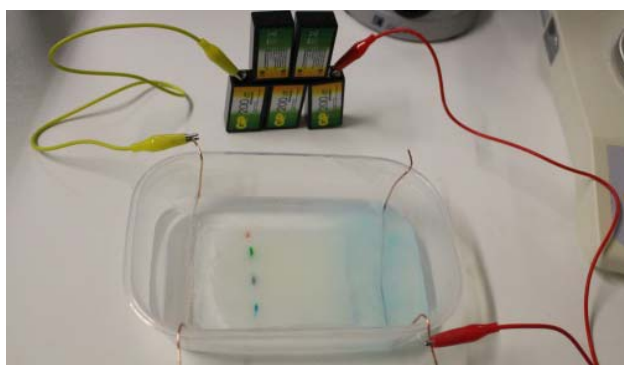

Figure 6. Electrophoresis power supply

#### 4. Final Considerations

The activities proposed to integrate the Forensic Science Educational Toolbox require an active participation of teachers and students and might have a decisive influence in motivating younger students to scientific subjects, hence deviating them from potential early dropout.

The activities presented in this paper were implanted in teachers' workshops which involve 47 teachers from basic and high school from

three countries (Portugal, Bulgaria and UK).

From the feedback obtained teachers enjoyed the activities and consider them with great potential to attract the attention of the students arousing students' interest in science and improving theoretical concepts understanding by practical experiments.

Some adjustments (for example in duration of some lab procedures) are to be considered according to the different educational systems.

The Forensic Science Educational Toolbox may be replicated in different countries and schools following the experience with participating partners and networking may easily be reached via web page (<http://www.euro4science.eu>) or facebook (<https://www.facebook.com/euro4science>).

#### 5. Acknowledgements

Euro4Science Project is Co-funded by the Erasmus+ Programme of the European Union. Grant Agreement number 2014-PT01-KA200-001012.

#### 6. References

- [1] [http://ec.europa.eu/news/culture/110202\\_en.htm](http://ec.europa.eu/news/culture/110202_en.htm) [visited 15-Jun-15].
- [2] <http://www.euro4science.eu> [visited 24-Jun-15].
- [3] Souto L, Moreira H, Tavares F, Pinho R. Euro4Science: exploring forensic science popularity to promote young people's interest in science and technology. Presented at this Congress. 2015.
- [4] Thompson RB and Thompson BF. Illustrated Guide to Home Forensic Science Experiments. O'Reilly. 2012.
- [5] Bertino AJ. Forensic Science: Fundamentals & Investigations. South-Western. 2012.

## Euro4Science: Exploring Forensic Science Popularity to Promote Young People's Interest in Science and Technology

*L Souto, H Moreira, F Tavares,  
R Fidalgo, R Pinho  
University of Aveiro, Portugal  
lsouto@ua.pt*

**Abstract.** The European Euro4Science educational project is an opportunity to motivate students for sciences.

The project implements both an educational toolbox and a program of exchanges between European students engaged in science fair like weeks, the CSI Weeks.

Before the launching of the educational toolbox, teachers have been trained and evaluate the feasibility of the proposed activities in the context of real classrooms.

**Keywords.** CSI Effect, Euro4Science, Toolbox, Transdisciplinary, Workshop.

### 1. Introduction

In the last years due to popularization of crime scene investigation TV series as well as the medialization of justice forensic sciences became very attractive to the general public and particularly to young students.

The European project Euro4Science is an opportunity to explore the potential of Forensic Sciences to educational purposes, promoting hands on experiences, interdisciplinary and the dialogue between science and society.

The project is a strategic partnership involving an university (University of Aveiro, Portugal), secondary schools (Agrupamento José Estêvão from Portugal and Skipton High School from UK), associations (*Know and Can* from Bulgaria and private sector (Inova+ from Portugal and INnCREASE from Poland).

The use of Forensic Sciences as motivation may contribute to mitigate recognized concerns such as school dropout and low interest in STEM (Sciences, Technologic, Engineering and Mathematics).

### 2. The major objectives

The project Euro4Science includes as main goals:

- a) To develop, test and implement a Forensic Science Education Toolbox in 4 languages (English, Portuguese, Bulgarian and Polish) to be used in European Schools.
- b) Organise three “CSI weeks” with a range of exciting activities for pupils while engaging the whole learning community and local stakeholders.

#### 2.1. The Forensic Science Educational Toolbox

The Forensic Science Toolbox (Fig. 1) is the main output of the project. It consists of an educational kit, constructed with hands on science materials, complemented by resources available at high schools. After a previous screening of potential forensic experimental activities that may satisfy educational requirements, an initial portfolio of activities has been tested in the university Lab (project coordinator Department of Biology, University of Aveiro).

In the frame of the Euro4Science project, a strategic partnership that explores the potential of “CSI effect” in education, an Educational Kit is conceived proposing a series of attractive experimental activities which include main topics as Biology and Biodiversity, Toxicology, Human Individual Identification and Bioinformatics.



**Figure 7. CSI Toolbox**

Teachers in Portugal, Bulgaria and the UK test during three months the Toolbox in the respective countries and educational contexts.



Partners discuss the adjustments required to develop the final version of the Toolbox, so that it is adequate to the context and needs of each national reality. The final version of the Toolbox will be firstly developed in English. After being validated by all partners, it will be translated to Portuguese, and Bulgarian. An additional version of the Toolbox will be created in to polish to be presented in the final International Multiplier event in Poland.

### 2.1.1. Exploring forensic cases

While the Forensic Science Educational Toolbox is an experimental kit it's strongly encouraged that activities will be contextualized by forensic cases.

Forensic cases may be real cases or fake and ad hoc cases developed by students. Historical issues as the Russian Romanov killing or the former Nazi doctor Joseph Mengele or the discovery of Richard III bone in UK, or known forensic cases that local communities are quite aware. Those cases serve as motivational vectors of the toolbox experimental activities but can also represent a gold opportunity for inter-disciplinarily (cases may be dramatized in class of arts or be written and constructed in Language and Literature or discussed by its societal challenges in Social Sciences.

## 2.2. CSI Weeks

The CSI week is the second main output of the project. It is not "simply" a one-week event, but rather the result of a series of initiatives and activities carried out in European High Schools during the project implementation and support materials that allow these activities to be replicated in several other schools across the EU.

In each country, the CSI week is associated with multiplier events and short-term exchanges of groups of pupils.

During the CSI Weeks, schools in Portugal, Bulgaria and the UK host a programme with different activities including: sharing experiences of Educational Forensic Science Projects; presentation of "CSI cases" and development of activities around them, such as theatre/drama with a crime scene scenario; bioethical debates; conferences and debates with teachers, students, and other

stakeholders/organisations with law enforcement and forensic scientists; implementation of the toolbox and science fair projects.

## 3. Workshops

After a beta version of the toolbox the educational kit was tested and optimized.

Three workshops were organized in Portugal, UK and Bulgaria. In each of the workshops the toolbox was presented and tested. A total of 47 teachers from basic and high school were involved in the toolbox training, testing and evaluation (Fig. 2)



Figure 8. Teachers workshop in UK

The activities performed during the workshops were:

- 1) Blood analysis
  - i) Is this really blood?
  - ii) Blood typing analysis
- 2) Document Analysis
  - i) Invisible writing
  - ii) Deciphering pen inks Chromatography
- 3) Forensic botany
  - i) Study of pollen
- 4) Fingerprints
  - i) Study your fingerprints
  - ii) Dusting and lifting latent fingerprints
  - iii) Revealing latent fingerprints using superglue fuming
  - iv) Revealing latent fingerprints using iodine fuming
- 5) DNA fingerprinting
  - i) Electrophoresis

### 3.1. Discussion

Within teacher's workshops an activities

feedback form was presented to participants in order to evaluate protocols, classroom implementation and potential of students motivation and background to perform the forensic toolbox activities.

There were five general questions and two specific questions assessing each activity. All the 47 participating teachers considered the activities performed in workshop as interesting.

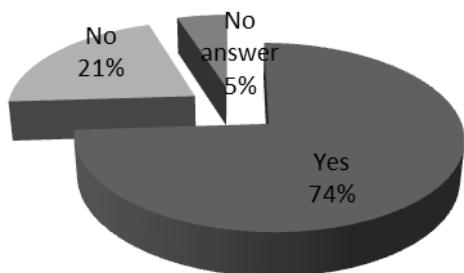

**Figure 9. Graphic representing the question “Do you think any of the activities can improve in any way the subject you teach?”**

When asked if activities would represent an improvement for their classrooms, in general teachers emphasize that this strategy may increase students’ motivation and improve understanding of theoretical educational concepts (Fig. 3). Some participants refer adjustments in order to fit school timetables requirements. Although having pre-made reagents (or even test results) may save precious time, we consider that lab procedures including preparation of solutions may have an important educational value.

The specific questions for evaluation were: “Which activities were most interesting?” and “Which activities do you think will most attract the attention of your students?” The following graphic (Fig. 4) represents the compilation of answers from teachers from the three countries.

The most interesting activities were “Is this really blood?” and “Study your fingerprints”. Some activities were less recognized but in general this was due to the facts that those are still in progress (“Forensic botany” and “Iodine Fuming”) or not yet included in some of each national workshop.

The Fig. 5 to 10 show some activities performed in the teachers’ workshops.

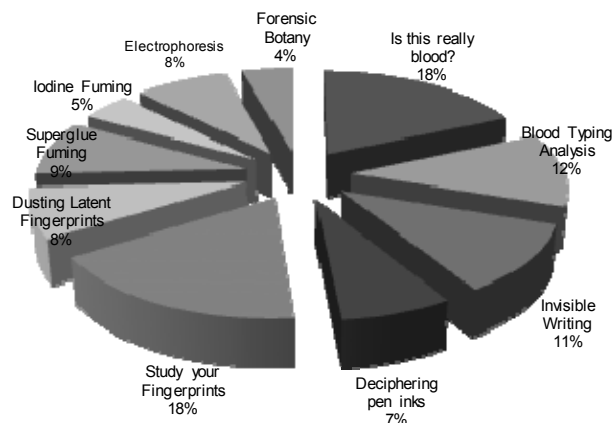
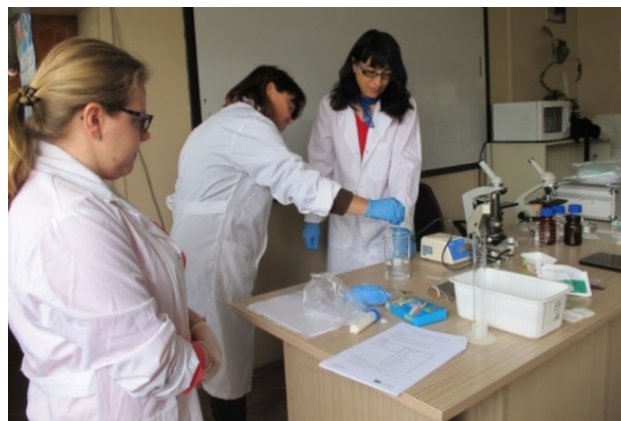

**Figure 4. “Which activities were most interesting?”**

#### 4. Final Considerations

This project gave opportunity to all partners to explore new subjects and ideas.

After the discussion in workshops and their respective feedback the optimization of the toolbox is the most important goal to achieve. The feedback from all the teachers was important to understand which activities have to be optimized and tailored into a protocol that corresponds to all the needs of a classroom.



**Figure 5. Bulgarian teachers doing electrophoresis**

During the workshops the coordination has received important contributions and relevant information in terms of comparisons of educational systems and lab and general school facilities. For example Bulgaria exhibited less resources and fewer occasions for lab experiments integrated in curricula. On the opposite side is the UK participant offering the free access of teachers and their students to a university facility specially dedicated to science education (university of Bradford STEM Centre).





Figure 6. Bulgarian teachers in workshop

The CSI Weeks and a final conference in Poland will be complemented by a multilingual webportal available to every school interested in applying this exciting and motivating educational strategy.



Figure 7. Portuguese teachers doing Kastel-Meyer activity



Figure 8. Portuguese teachers in Blood typing analysis

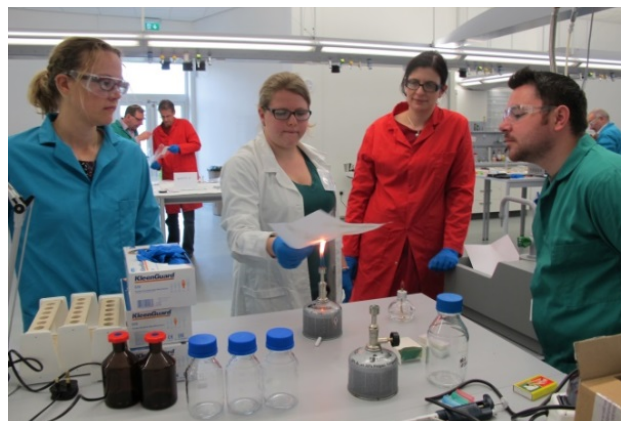

Figure 9. UK teachers doing Invisible writing activity

## 5. Acknowledgments

<https://www.facebook.com/euro4science>  
<http://euro4science.eu/>

Euro4Science Project is Co-funded by the Erasmus+ Programme of the European Union. Grant Agreement number 2014-PT01-KA200-001012.



Figure 10. UK teachers in workshop

## 6. References

- [1] <http://euro4science.eu/> [visited 24-Jun-2015]
- [2] Souto L, Tavares F, Moreira H, Fidalgo R, Pinho R. Euro4Science Forensic Science Education Toolbox – Demonstration of Beta Version Presented at HSci 2015.
- [3] Bertino AJ. Forensic Science: Fundamentals & Investigations. South-Western. 2012.



## Modeling the Neuron!

C Medeiros y Araujo, AS Lima-Marinho  
University of Brasília, Brazil  
[www.somosfeitosdecelulas.unb.br](http://www.somosfeitosdecelulas.unb.br),  
[yaraujo@unb.br](mailto:yaraujo@unb.br)

**Abstract.** In order to create, test and make available free and low-cost educational material that can help teaching and improve understanding of cellular aspects by students, the project We are made of cells! (Somos feitos de células!) presents an activity that combines cytological concepts and modeling. Through this activity, a teacher can encourage group discussion that combines morphology and specialized functions of the myelinated multipolar neuron. This is a didactic sequence subdivided into steps through which participants remember, learn and share cellular concepts, perform modeling activities, improve scientific vocabulary, share and analyze their models and compare them to other learning resources.

**Keywords.** Cytology, modeling, neuron.

### 1. Introduction

Molecular and Cell Biology classes in Brazilian high schools, still known as Cytology, imply in a lot of abstraction resulting in mental maps created by students without necessarily being stimulated socialization of these mental models in classroom. In Brazil, it is common that Cytology classes were developed by lectures supported by numerous and sophisticated scientific cell structure images, especially illustrations and photographs available in textbooks and internet. To organize extensive and complex scientific information, teachers and textbooks' authors choose to content fragmentation showing cytological topics in a class sequence that may not facilitate the understanding of this content that is characterized by cellular and extracellular components interrelation. In order to create, test and make available free and low-cost educational material that can help teaching and improve understanding of cellular aspects by students, the educational project *Somos feitos de células!* presents an activity that combines the acquisition of cytological concepts and modeling. It was elected a well-known and differentiated cell type, the myelinated multipolar neuron, and through a modeling

process, a teacher can encourage group discussion that combines morphology and specialized cellular functions. This activity was elaborated to be presented through a didactic sequence with total duration of one and half to two hours, subdivided into steps through which participants can remember and share scientific concepts, perform modeling activities, improve scientific vocabulary and analyze their own models. The teaching process is based on the "model of modeling" [1,2] which includes some principles and steps of science education such as meaningful learning; development of mental maps; elaboration of models (empirical testing); socialization of models in classroom; analysis of the scope and limitations of the models. Under this approach, a sort of biological topics discussions can be included such as cell three-dimensionality, cell morphology with specialized components, cellular communication through chemical synapses and transmission of nerve impulses. This activity was developed and improved from previous experience [3], activities developed from 2011 to 2015 in undergraduate courses at our university with participation of 180 students and actions undertaken by the project *Somos feitos de células!* during 2013 and 2014 with 200 participants, mostly high school students [4].

### 2. Objectives

Model a clay sculpture of a myelinated multipolar neuron. Plan and build a neural network with a set of models to discuss topics like neuron communication. Plan and build peripheral nerves with a set of models to discuss topics such as nerve impulse transmission. Compare models with textbooks' scientific images to highlight the similarities and differences between different learning materials.

### 3. Materials (Fig. 1A)

- Two clay sticks of color 1 (yellow, in our case) and one clay stick of color 2 (green, in our case);
- Six pieces of thin wire with 5 cm length each, to represent the cytoskeleton of the main dendrites;
- Eight to twelve pieces of thin wire 1 to 1.5 cm length each, for the cytoskeleton of the main branches of dendrites;

- A piece of thick wire 13 cm in length to the cytoskeleton of the axon;
- Two pieces of thin wire 4cm length each, for the final branches of the axon;
- A wooden board (or cardboard or a piece of tile) of 10cmx10cmx1cm;
- A conceptual label to glue on the back of the wooden board;
- Five flags made of paper and toothpicks, each one with a keyword: cell body, dendrites, axon, Schwann cell or internode, Ranvier node or node.

#### 4. How to do it

##### 4.1. Modeling the myelinated multipolar neuron

- Separate one stick and a half of clay color 1 to sculpture the cell body and dendrites. Build a ball and insert in it six wires (5 cm each) in various directions. Sink each piece of wire to leave exposed just 3 cm of each one (Fig. 1B).
- Pull the ball clay with your fingertips to cover completely each of the wires. As moving away from the ball, decrease the diameter of each clay projection resulting in a central structure (cell body) with gradually thinner dendrites (Fig. 1C).
- Hold all 1-1.5 cm long wires and wrap each one with a small amount of the remainder clay color 1. Leave one end of each wire exposed and sink them on the ends of the main dendrites (Fig. 1D) to form more branches of dendrites.
- Get the 13 cm long wire, covering it with almost all remaining color 1 clay from the wire center to the edges, keeping the same diameter throughout all the structure. Leave one of the wire ends without coating to connect it to cell body. At the covered edge, form a small knob to represent a terminal button. With 4 cm-wires, cover each one in the same manner (with the last remainder of color 1 clay), inserting them next to end of the axon (Fig. 1E-F-G).
- For the myelin sheath, hold the color 2 clay and cut it into 3 or more equal portions depending on axon length. Flatten each

piece to form long and narrow flat structures. Each piece of clay represents a Schwann cell and should involve concentrically and sequentially all the axon (Fig. 1H-I-J).

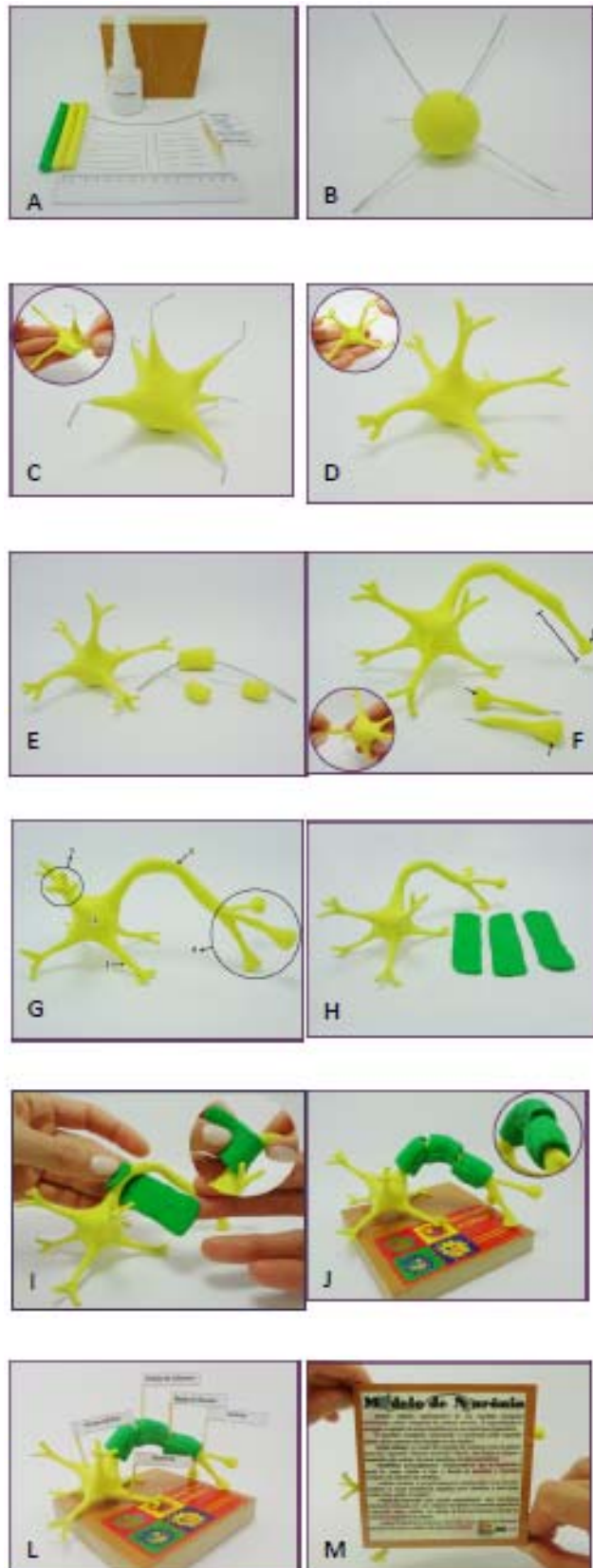

Figure 1. Stages of myelinated multipolar neuron modeling

- If you have to end the activity at this stage, insert the conceptual flags concomitantly with reading of label (glued in the wooden board). You can ask the students themselves to develop all the labels as a glossary activity. Glue each model in a wooden board. By using a good quality adhesive, the board could be manipulated freely (Fig. 1L-M). If you have more time, do not glue the model and go to Part 4.2 and 4.3.

#### **4.2. Building neural networks**

- After finishing individual models and before inserting the flags and glue models on the wooden boards, explore cell communication with your students. Request for students to approach their models (without flags) and form a neural network on a flat surface, for example, the teacher's desk or the floor of the classroom.
- Observe and discuss the positions of the models adopted by students.
- Discuss and consolidate concepts as chemical synapses and how each neuron can form many connections simultaneously and be influenced by these different connections. Explore the fact that synapses can occur between axon and dendrites as well as axon and other neuron parts like other axon and neuron body. The students represent all these possibilities? Discuss with them.

#### **4.3. Discussing peripheral nerves**

- With the same set of neuron models, ask students to conceptualize nerve fibers and to represent peripheral nerves.
- Observe and discuss the positions of the models adopted by students.
- Discuss and consolidate the concept of nerve fiber and peripheral nerve, the position and length of these structures in the human body and the synapse formation with other cell types such as muscle fibers and exocrine glands.

#### **4.4. Comparing the model with other learning materials**

- Ask the students to compare their models with scientific illustrations, for example, those

from their own textbooks. You also can find histological pictures of neurons in our *Histologia UnB* fanpage [5].

- Ask students to observe and register which structures in their textbooks' pictures were showed in the multipolar neuron model and which were not reproduced during this modeling activity. Encourage a discussion about qualities, limitations and complementarity between these different learning resources.

#### **5. Acknowledgements**

The authors acknowledge financial support from FAPDF - Fundação de Apoio à Pesquisa do Distrito Federal which provides the funds to allow our participation in this conference.

Thanks go to many students who participate in this activity allowing its improvement.

#### **6. References**

- [1] Justi RS, Gilbert JK. Modelling, teacher's views on the nature of modelling, and implications for the education of modelers. *International Journal Science Education* 2002; 24(4): 369-387.
- [2] Justi R. La enseñanza de ciencias basada en la elaboración de modelos. *Enseñanza de las Ciencias* 2006; 24(2): 173-184.
- [3] Moreno NP, TharpBZ, Grandpré T. *Brain Chemistry Teacher's Guide*. Houston: Baylor College of Medicine; 2013.
- [4] UnBTV – Prazer em Conhecer, Canal Universitário de Brasília: Oficina Modelando o seu neurônio. <http://www.youtube.com/watch?v=1Z2hZeDYHIY> [visited in 21-June-2015]
- [5] *Histologia UnB*. <http://www.facebook.com/HistologiaUnB> [visited in 21-June-2015]

## Bio-Battery: Biomass Electrolyte

*M Firdaus-Nawawi, M Aziz-Khan, E Motius*

**Abstract.** Researchers have found a way to harness bio energy in a simple, inexpensive carbohydrate to generate electrical power. The resulting "biobattery" can hold more juice per ounce than similarly sized lithium ion batteries, using only biodegradable compounds. Biomass compound can be found anywhere around us. This is a cheap alternative energy. In this workshops, participants will be thought on how to build a biomass battery base on the battery electrochemical principles. It will include the process of observation, building, and testing the bio battery itself.

### 1. Introduction

Electrical Energy is one of the most important source of energy in the world mainly to power up electronic devices. Modern days research and development have make the access for power easier by the invention of battery. An electric battery is a device consisting of two or more electrochemical cells that convert stored chemical energy into electrical energy. The most well-known primary battery has long been the common "dry cell" that is widely used to power flashlights and similar devices. The modern dry cell is based on the one invented by Georges Leclanché in 1866. Each cell contains a positive terminal, or cathode, and a negative terminal, or anode. Most primary cells utilize electrolytes that are contained within absorbent material or a *separator* (i.e. no free or liquid electrolyte), and are thus termed dry cells. The internal workings of a battery are typically housed within a metal or plastic case. The reaction in the anode creates electrons, and the reaction in the cathode absorbs them. The net product is electricity. The battery will continue to produce electricity until one or both of the electrodes run out of the substance necessary for the reactions to occur. Modern batteries use a variety of chemicals to power their reactions. Common battery chemistries include Zinc-carbon battery (zinc (anode), manganese dioxide (cathode) and ammonium chloride or zinc chloride (electrolyte)) and Alkaline battery (manganese dioxide mixture (cathode), zinc powder (anode) and potassium hydroxide (electrolyte)).

In recent years, scientists and researchers have start to venture into the new realm of green energy in producing sustainable energy that is low-coast and environmentally friendly. Renewable biomass materials is one of the important application prospect in the development of sustainable energy materials. Biomass refers to a broad range of biological material derived from plants - such as trees and forestry residues, agricultural and purpose-grown crops, and industrial or municipal waste products -that can be transformed into renewable power. Biomass is a remarkably diverse, widespread, and abundant energy source. The potential for economically harvestable biomass exists nearly everywhere on Earth. Researchers have long recognize the promise of functional organic polymers, but the challenge is to developed an efficient electron-transport conducting polymer to pair with the established hole-transporting polymers.

One of the main purpose for this program is to educated people about biomass energy and how it can be applied in replacing the normal chemical base battery. This experiment utilised dry leaves as the biomass material, as it can commonly found anywhere.



### 2. Method

This workshop will be separated into three section; Battery 101, Biomass Paste and Testing & Application. All of this method will be focusing in giving a better understanding on principals of battery and how to utilised the biomass energy.

#### 2.1. Battery 101

In this section, participants will be introduced



to the parts and the principles of a battery. For interactive purposes, participants will be given an old battery or one that will be disposed, for start. The battery will be opened up at the very top using appropriate tool, and all the electrolyte in the casing will be taken out. Participants will need to identify each section of the battery based on the theoretical diagram given. In this workshop we will be focusing on the three main parts of battery that is the cathode, anode and electrolyte, and their function in the battery.

Rinse the inside of the battery with distilled water for a few second and let it dry. The battery parts will be used in the next section later.



## 2.2. Biomass Paste

Participants will be given a few items and they will be ask to discuss which items fit the term of biomass. Participant will be given the

chance to sampling their own biomass substances, as they are abundance in the environment. To create the biomass paste, fold an aluminium foil into a box shape. Weight about 100 grams of dry leaves and place it on the Aluminium foil. The next step is to burn all the dry leaves until it turn to ashes. Let the ashes cold for a few minute, before adding 2.5 ml of distilled/deionized water into the mixture to create a paste like substances.

To create the biomass battery, replace the hollow battery casing with all the ashes-paste and put the battery cap back on. To ensure that the electrolyte will not spill out, secure the top of the battery using selloff tape.

## 2.3. Testing and Application



To test the battery power, a multimeter was used to measure the voltage (V) and milliamps (mA) generated from the biobattery. The ultimate test is to use the bio-battery to move a

clock or to light up an L.E.D.

### 3. Discussion

This program was conducted with students age range from 12 to 16 years old under NSC GreenTech Camp Program. One of the sole aims of this program is to create an understanding about the usage of green and alternative energy using hands on activity.

Battery was choose as a medium because ; (1) it is widely use and (2) it has the simplest design in understanding bio electrical process. Observation of battery parts helps in understanding the process at anode, cathode and the electrolyte, as the main player in generating energy. The goal is so that the participants would understand what and why thus this particular parts of the battery were chosen to be replace; in this case the electrolyte.

The chemical reaction between the electrolyte and the zinc canister (anode) produces a surplus of electrons at the negative terminal. The graphite rod (cathode) that act as the positive terminal has far fewer electron thus creating a potential differences between the two electrodes. The electron would want to equalise this difference by moving toward the lower build up at the positive terminal through and by the electrolyte.

As a medium of electron transfer, the electrolyte can be replace by other chemical or biological compound that have similar properties. Choosing the later gave us more diverse.

The process of creating the biomass paste is a way to show the treatment of bio mass substances before it can be applied as part of energy generating components. Burning the dry leaves sample helps remove lignin, an amorphous, three dimensional, aromatic polymer composed of oxyphenylpropane units. Electrolyte paste should be free from this substances to allow electron to move freely in the electrolyte. To enhance this effect, dry leaves can also be treated first with 2% w/v Sodium Hydroxide (NaOH) solution for 24 hours before being autoclaved at 121 degree Celcius, 15 pound square inch (psi).

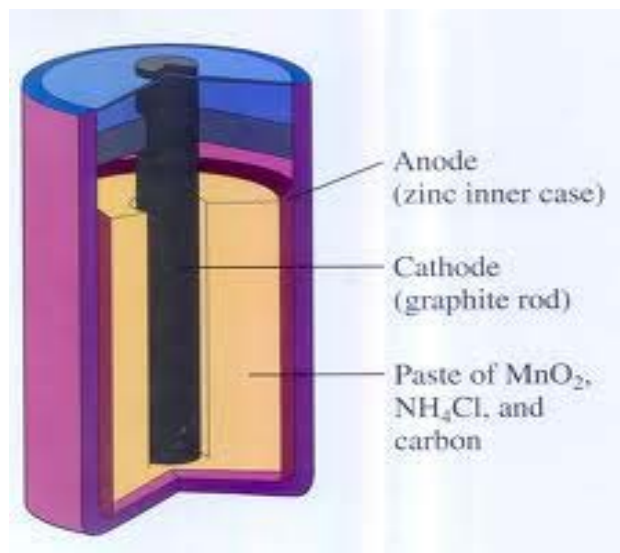

A grey powder ash will be obtained after the dry leaves was burnt. Participants by now should have a very firm idea on how an electrolyte paste should look like base on the first observation inside the battery.

Replacing the battery chemical electrolyte with bio base electrolyte create a safe and biodegradable battery. Application of the biomass energy were shown by the multimeter test and the power it supplies to move the clock or lighting up the L.E.D. This part is important as to test the functionality and practicality of the theory learned by participants. The bio battery could generate more than 1.0 V at ambient temperature. This hands on methods give way for participants to later on design and create their own bioenergy power source. This will enhance their creativity and thinking skills.

### 4. Conclusion

This type of hands-on activity give better understanding of electrochemical process of a battery and in reengineering the type of power source used. Discovering alternative energy opens the door for cheaper alternatives to traditional inorganic-based energy devices and could make for cheaper electric powered gadget. Nonetheless, an interesting step toward a possible future of running some of our gadgets on biofuels.



# Biodiversity and Species Extinction: STSE Inquiry Based Activities about the Consequences Induced by Volcanic Eruptions in the Tree of Life and in Travelling and Tourism by Humans

C Sousa  
Universidade do Porto, Portugal  
up199502480@fc.up.pt.

**Abstract.** The main problem-based activities proposed to both middle and high-school students (Life Science topics) were “what are the interactions STSE related to volcanic eruptions in Iceland?”. The focus of the IBSE was Grimsvotn and Bardarbunga case studies as well as the submarine El Hierro in the Canary Islands.

**Keywords.** IBSE, tree of life, volcanic eruptions, Google Earth hands-on and minds-on activities.

## 1. Introduction

In the context of the International Year of Small Island Developing States, in 2014, and the Biodiversity decade [1] it was considered to be important to discuss with the students the role of the environmental changes caused by volcanic eruptions in evolution and on the tree of life, mainly in the construction and destruction of novel habitats.

### 1.1. Background

It is a pleasure to present to your consideration a workshop that was inspired in the environment such as the Aurélia de Sousa High School, an UNESCO's associated school (of ASP net), that was created with a similar propose of the Francisco Franco High School of providing the community with a service of training and education in the area of Technologies [2] and Arts (Fig. 1).

## 2. Guidelines / curriculum suggestions

In the context of your (HSCI) theme for this year “Brightening our future” one thought about this and the continental platform that is quite undernoted, but of utmost importance to discuss with our portuguese and european

students. The main topic of this presentation is “Science education. New challenges, new perspectives, innovative solutions” using IBSE (Inquiry Based Science Education) focusing on the main high school curricula of Life and Earth Sciences disciplines, mainly Biology and Geology [1], as well bridging the topics under focus to other disciplines, such as Geography and Computer Science [2], and Health Sciences topics.



**Figure 1. (a) Aurélia de Sousa high school (logos on the left: UNESCO associated school and 40th anniversary of world heritage convention); (b) Francisco Franco High School european conference initiative**

## 3. Problematic situations

### 3.1. What are the interactions STSE-related to volcanic eruptions in Iceland?

STSE discussion about Grimsvotn and Bardarbunga was performed and will be further explored during the oral presentation and/or workshop in situ in the HSCI2015 [3].

### 3.2. What are the interactions STSE-related volcanic eruptions under glaciers in Iceland?

Discussion about Surtsey, and the characterization of the greatest threats currently face to island ecosystems; as well as their greatest vulnerabilities.

### 3.3. What are the constructive consequences of volcanic eruptions?

Discussion about the Selvagens and the submarine El Hierro in the Canary Islands were discussed.

### 4. Acknowledgements

To the Faculty of Sciences of University of Porto, to the colleagues directly involved in the inspiration and design of this presentation, as well as the faculty deans (mainly 2012-present).

To the Aurélia de Sousa High School faculty, mainly the administrative personnel (since 2012 to the present), the students and teachers/colleagues involved (in)/directly in this project.

### 5. References

- [1] Sousa C. Biodiversidade e Extinção de Espécies: Webquest (volume 1). E-book, 2011, ISBN: 978-989-97682-0-8. Casa das Ciências.
- [2] Sousa C. Google Earth no ambiente de aprendizagem de Ciências Naturais: informações georreferenciadas, em tempo-real e cenários futuros. *In*: Aprendizagem Online: Atas do III Congresso Internacional das TIC na Educação. 2014. Instituto da Educação da Universidade de Lisboa. ISBN: 978-989-8753-08-3. p715-720.
- [3] Sousa C. Biodiversidade e extinção de espécies (3 volumes): Questões-problema sobre as consequências das erupções vulcânicas (volume 2) 1ª edição - Novembro 2014. Editor: (de autor)/Casa das Ciências. ISBN: 978-989-97682-0-8.



## The Scientific Concepts in Biology Textbooks

*M Ornelas, C Horta, D Aguin-Pombo  
Universidade da Madeira, Portugal  
marcia\_ornelas@yahoo.com,  
cristinahorta@yahoo.com, aguin@uma.pt*

**Abstract.** Learning a science requires the understanding of its language, and the textbook as an educational resource, stands out in the whole teaching process, particularly in the years before the national tests. To what extent, do biology textbooks represent a strategic instrument for teaching and learning and a vehicle of the curricular message? All biology concepts covered and defined in the two biology 10<sup>th</sup> grade textbooks that are most adopted in Portugal, were quantified using a comparative study. The results showed that these textbooks covered more than 90% of the concepts recommended in the curriculum guidelines, although the total number of concepts was 6.5 to 7.5 times bigger than suggested.

**Keywords.** Biology, Concepts, Secondary school, Teaching and learning, Textbook.

### 1. Introduction

The key to learning any science lies in understanding its language [1]. Biology is a science that gathers knowledge, facts, theories and principles and, as such, many concepts. However, not all are equally relevant in order to profoundly structure a biological way of thinking. Given this, some authors suggest that biology teaching should be based on a justified selection of the most important concepts [2], [3]. Regarding this, the Ministry of Education (ME) in the Curriculum Guidelines for Secondary Education, identifies the most relevant concepts as well as the appropriate teaching methods for fulfilling the curricular programme [4].

The curricular programme of this subject aims to promote meaningful learning in the youth in order for them to achieve scientific literacy, which is fundamental for assuming a proactive attitude on scientific issues or matters relating to their life and to the life of others [4], [5]. Knowing that knowledge is constructed and reconstructed from the selection of different information acquired throughout life, it is expected that as a privileged educational

resource, the textbook should be in perfect coordination with the goals and overall objectives of the Curricular Programme. The textbook should contribute to the construction of a solid body of knowledge and to the development of various skills [6], [7] promoting in the student, an autonomous learning, particularly in school years prior, and that prepare for, exams that give access to Higher Education.

The importance of language, vocabulary and concepts used in school textbooks has been studied for different purposes. Some studies address the importance of language in the construction and communication of scientific ideas [1], [8]. Others check to what extent the concepts explored in the Science and Biology textbooks approximate or differ to the knowledge of reference, in other words, to the knowledge that is the object of study of the teacher in training [9]. There are others that identify the most important biology concepts that student must know, demonstrating the existence of a discrepancy between the number of concepts that students are able to learn and the time available for such learning [2]. Some textbook studies have also evaluated the key contents that enhance scientific literacy in students [10], and created a list of the most important concepts in Biology [3].

In Portugal, very few studies have been made involving biology textbooks. Some of these studies compare the message of the Natural Science textbooks of the 3<sup>rd</sup> cycle of basic education with the recontextualization processes that take place in the curriculum message during the elaboration of the textbooks [11], [12]. However, none focused to what extent the 10<sup>th</sup> grade Biology and Geology textbooks represent a strategic instrument for teaching and learning and a vehicle of the curricular message proposed by the Ministry of Education, particularly regarding the recommended biology concepts.

The aim of this study is the quantification of the number of biology concepts referred to in the Curriculum Guidelines of the Ministry of Education that are presented and defined in the two selected textbooks as well as evaluate whether these number of definitions allow the student an overall understanding of the content and an autonomous study during the years prior to the exams that give access to higher education.

## 1.1. Selection of the textbooks

The textbooks selected for analysis were the two most adopted 10<sup>th</sup> grade Biology and Geology textbooks of the secondary schools in Portugal during the school year 2012/2013, one from Areal Editores [13] and the other from Porto Editora [14], according to data confirmed by the publishers. These textbooks were also the most used in the secondary schools of the Autonomous Region of Madeira (ARM).

Each textbook consists of two volumes, one of biology and another of geology. In this study, only the Biology volumes were analyzed.

## 2. Methodology

Direct research and the descriptive method were used to develop a descriptive/ comparison type of study [15], [16]. Based on this method an inventory was made of all biology concepts present in both analyzed textbooks.

The textbook analysis was performed by two investigators. Each one fulfilled a complete analysis of one of the textbooks, quantifying all the biology concepts present in the text, illustrations, text boxes and activities, except for the ones present in headers and titles, in theme presentation pages of the unit or chapter and in the questions of the consolidation activities along each chapter or at the end of it. Each concept was checked in order to verify if it had a definition in the text, in illustrations, in text boxes and in the glossary (if any), and if the concepts were considered by the Curricular Programme of the subject, as mandatory concepts to be covered [2]. Each concept was counted once, regardless of the number of times it appeared in the textbook. Given the high number of synonyms of some concepts, all terms for the same concept were considered as a single one.

In order to standardize criteria and avoid ambiguities in data collection, definitions were created for concepts such as *Text*, *Illustration*, *Text box* and *Activity* (Table 1). The textbooks were analyzed gradually, page by page, marking and quantifying all the concepts and respective information regarding the definition. During the data collection process, all doubts and questions raised were marked and discussed weekly between the two researchers, in order to minimize the margin of error. Once the analysis was carried out, the

same researcher performed a second reading in order to detect possible omissions. A data matrix was created in an Excel spreadsheet with the gathered information.

Analysis Criteria	Definition
<b>Text</b>	Any set of linked words or sentences contained in a particular chapter, except for the information highlighted in text boxes, in illustrations or in activities.
<b>Illustration</b>	Figure, graph, table, diagram, concept map, photograph, geographic map or chart contained in each chapter.
<b>Text Box</b>	Any set of linked words or sentences highlighted outside an illustration or activity in order to complement or add new information regarding the contents already presented in the body text, illustrations or activities.
<b>Activity</b>	Any proposed exercise in a chapter whether it is practical or experimental in nature, formative, informative or associated to Science, Technology, Society and Environment (STSE).

Table 1. Definition of the analysis criteria for data collection

### 2.1. Study variables

The variables selected were four dichotomous qualitative variables recorded in nominal scale: Term of the concept, Textbook, Definition and Reference of the concept in the Biology and Geology Curricular Programme.

These variables were summarized numerically in order to enable their comparison in absolute terms.

The variables were defined as follows:

*Term* – The presence (1) or absence (0) of the term was checked and its designation was registered.

*Textbook* – The analyzed textbook was identified (Areal Editores and Porto Editora).

*Definition* – The presence (1) or absence

(0) of a definition was checked for every concept found. Its location in the textbook was not taken into account, and neither was a qualitative evaluation of the definitions performed.

*Reference in the Curricular Programme of the ME* – The presence (1) or absence (0) of the term in the Curricular Programme was checked in each chapter of the textbook. When the concepts proposed by the ME in the textbook were referred to by synonymous terms, they were also considered present (e.g. *Facilitated transport* in the curricular programme versus *facilitated diffusion* in the textbook). When the concepts proposed by the ME were inserted in chapters that were not suggested by the curricular programme, its presence was not registered.

## 2.2. Data analysis

The process of analyzing and processing information went through three distinct phases: the description and reduction of information; the presentation and organization of the most relevant information and the interpretation and verification of data.

In the reduction information process, all terms considered common sense in the English language, although related to biology, were eliminated from the final data matrix, (e.g. air, grass, man, life, wind, thirst, and others), as well as some examples of living beings known in general by the students and that in the textbooks were not explained or addressed as explicit examples of concepts (e.g. bush, tree, camel, grass, mushroom, grasshopper, pig, etc.). All concepts considered of little relevance to answer the proposed research questions were also excluded from the data matrix, such as, those associated with laboratory activities, chemistry concepts, concepts associated with technology or with agricultural activities or with the nature of science, political and administrative concepts and concepts relative to other scientific areas.

## 3. Results

The number of biology concepts in both analyzed textbooks was considered very high, reaching a total of 2178 concepts. Each of the textbooks mentioned only half of these concepts, that is, 1161 concepts (53.3%) in the

Areal Editores and 1017 (46.7%) in the Porto Editora textbook. After excluding all synonymous terms and repeated concepts, 797 concepts prevailed in the Areal textbook (68.6%) and 696 (68.4%) in the Porto Editora textbook. Of these, only 504 (33.8%) were common to the two textbooks, while the remaining were addressed only in one of the two textbooks (293 concepts in the Areal Editores textbook and 192 concepts in the Porto Editora textbook) (Fig. 1).

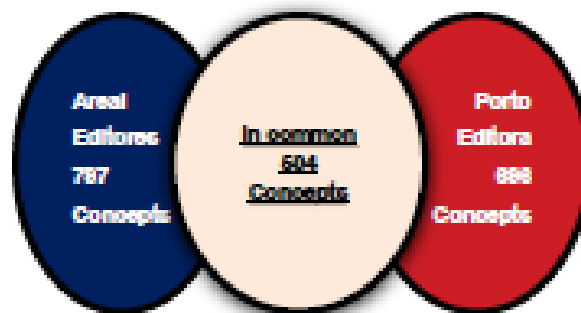

**Figure 1. The number of biology concepts in both textbooks**

The curricular programme of the Ministry of Education suggests the study of 106 scientific concepts of biology in the 10<sup>th</sup> grade. Any one of the two analyzed textbooks covered more than 90% of the biology concepts proposed by the ME. The Areal textbook explored 101 (95.3%) concepts and the Porto Editora textbook 99 (93.4%) concepts (Fig. 2).

In percentage terms, the biology concepts proposed by the ME accounted for only 12.7% of the total Biology concepts covered in the Areal Editores textbook and 14.2% in the Porto Editora textbook. The number of other biology concepts not suggested by the ME was about 6.9 times bigger in the Areal textbook and about 6 times bigger in the Porto Editora textbook, than the one suggested by the Curriculum Guidelines (Fig. 2).

None of the textbooks covered or defined all of the biology concepts proposed by the ME.

The Porto Editora textbook defined three quarters of the covered concepts (77 concepts - 77.8%). On the other hand the Areal Editores textbook defined less than half of the referred concepts (45 Concepts - 44.5%) (Fig. 3). If we consider that all the concepts proposed by the ME are considered fundamental for the understanding of the subject addressed and the progression of student's knowledge in other



related subject, we find that the number of defined concepts is clearly not enough to help the student learn Biology, particularly in the Areal Editores textbook.

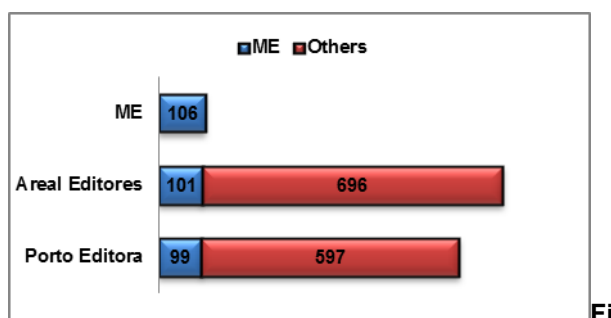

**Figure 2. The number of biology concepts suggested by the ME Curriculum Guidelines in the two textbooks and the number of other Biology concepts not suggested by the ME**

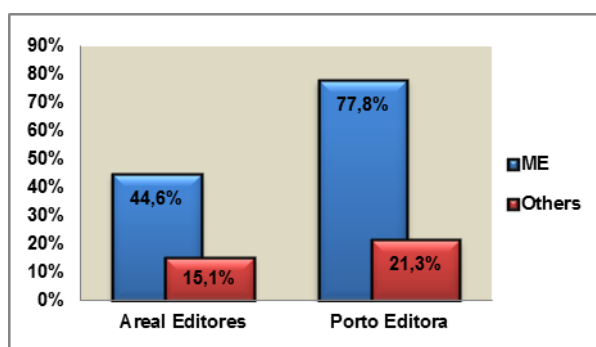

**Figure 3. The percentage of biology concepts suggested by the ME that present definition in both textbooks in comparison to the percentage of other concepts defined but not suggested by the ME**

Of all the concepts of the ME that each textbook covered, only 39 (86.6%) are defined in the two textbooks. The rest of the concepts were defined only in one of the textbooks. The Areal Editores textbook defined exclusively 6 concepts (13.3%) while the Porto Editora textbook defined 38 (49.4%). When comparing the number of concepts suggested by the ME that have definition in the Areal textbook (44.5%) and in the Porto Editora textbook (77.8%), with the number of other defined concepts not suggested by the curricular programme (Areal Editors - 15.1% and Porto Editora - 21.3%), we found that the biology concepts suggested by the ME were always the most defined in any of the textbooks (Fig. 3).

#### 4. Discussion

Today more than ever, great importance is given to the way the selection, organization and presentation of what we want students to learn

is made [17]. It is fundamental to find the best way to relate all concepts with the previous knowledge of the student. In this sense, the organization of the information, the amount of concepts and the way these are defined in the textbooks play an important role in student learning.

The textbook should not be a copy of the curriculum proposed by the Ministry of Education, however it should reflect its message. The biology concepts proposed by the ME in the analyzed textbooks were always the most defined, in relation to other biological concepts that were not suggested in the Curriculum Guidelines. However, only a third of the concepts of biology proposed by the ME (36.8%) were defined in both textbooks. When the meaning of unfamiliar concepts is not presented, the student needs the teacher's help in interpreting the scientific contents much more, which reduces his autonomy in the learning process [18]. If we consider that all biology concepts proposed in the Curriculum Guidelines represent those that the student needs to know in order to understand 10<sup>th</sup> grade Biology contents, we find that the number of defined terms in common in the two analyzed textbooks is clearly lower to what the student really needs to know.

In this sense, in secondary education the textbook assumes a crucial role during the preparation for exams that give access to higher education. The gaps found in the two textbooks indicate that the student should use more than one textbook during the study of the concepts recommended in the Curriculum Guidelines. In this way, the teacher's role is even more crucial to the understanding of the proposed concepts. It is up to the teacher and the school to make a critical evaluation of the textbooks to be chosen, so that the students get a good preparation and understanding of the subject [4], [11], [12].

The total number of concepts covered in each textbook is also relevant. This study showed that the total number of concepts covered in the textbooks of Porto Editora and Areal Editores was respectively 6.5 and 7.5 times bigger than the one suggested by the guidelines. In addition to the concepts of the ME, the number of other biological concepts not suggested, was 6.9 times bigger in the Areal Editores textbook and approximately 6 times bigger in the Porto Editora textbook than

suggested in the curriculum guidelines. These results are very similar to those found in the analysis of Biology textbooks of grade 7 and 10 in Germany [2]. The same authors found that taking into account the lesson time available, students had to learn a new concept every minute (1.4 minutes) in order to know all the concepts that the textbook presented [2]. However, since the number of concepts covered must be adequate to the time available for teaching and to the learning capabilities of students, these authors consider that only of two or four new concepts per lesson are possible to be learnt by students [2].

In Portugal, if we consider the 10<sup>th</sup> grade and relate the total number of biology concepts initially recorded in the textbooks (2178 concepts) with the time available per lesson throughout the school year (108 periods of 45 minutes or 4860 lesson minutes), and if we assume that the teacher teaches the whole textbook contents, we understand that students have to learn a new biology concept every 2.2 minutes, which is considerably exaggerated. The inclusion of a large number of concepts will only hinder the cognitive organization of the student and complicate the understanding of a particular matter. In this way, it becomes necessary to select the most important concepts and focus teaching on the essential concepts. It is important that a critical assessment of the most important concepts and of the most appropriate teaching strategies given the available time of the lesson is done, in order to promote meaningful learning.

## 5. Acknowledgements

We would like to thank the research teachers Estela Cabeço and Rúben Sousa for their collaboration in defining and implementing the methodology used in this study.

## 6. References

- [1] Anagnostopoulou, K., Hatzinikita, V. & Christidou, V. (2012). PISA and biology school textbooks: The role of visual material. *Procedia – Social and Behavioral Sciences*, 46: 1839-1845.
- [2] Graf, D. & Berck, K-H. (1990). *Concept learning in Biology – Is it satisfactory?: Plethora of concepts makes excessive demands on pupils*. [www.biologie.tu-dortmund](http://www.biologie.tu-dortmund) [visited in July 2014]
- [3] D’Avanzo, C. (2008). Biology concept inventories: Overview, status, and next steps. *BioScience*, 58 (11): 1079-1086.
- [4] Amador, F., Silva, C. P., Baptista, J. F. P. & Valente, R. A. (2001). Programa de Biologia e Geologia 10º ou 11º ano. Curso científico-humanístico de Ciências e Tecnologias. *Ministério da Educação*.
- [5] Kamil, M. (2010). *Adolescent literacy and textbooks: An annotated bibliography*. New York: Carnegie Corporation.
- [6] Santo, E. M. (2006). Os manuais escolares, a construção de saberes e a autonomia do aluno. *Auscultação a alunos e professores*. *Revista Lusófona de Educação*, 8: 103-115.
- [7] Carvalho, A. D. & Fadigas, N. (2007). *O Manual escolar no século XXI: Estudo comparado da realidade portuguesa no contexto de alguns países europeus*. Observatório dos Recursos Educativos (ORE).
- [8] Fisher, D. & Frey N. (2010). The value of intentional vocabulary instruction in the middle grades. *Professional Development Series*, 16: 1-12.
- [9] Franzolin, F. & Bizzo, N. (2007). *Conceitos de Biologia em livros didáticos de educação básica e na academia: Uma metodologia de análise*. Anais do VI Encontro Nacional de Pesquisa em Educação em Ciências 26 Nov. – 1 Dez. 2007, Florianópolis, Santa Catarina, 12 pp.
- [10] Udeani, U. (2013). Quantitative analysis of secondary school biology textbooks for scientific literacy themes. *Research Journal in Organizational Psychology & Educational Studies*, 2 (1): 39-43.
- [11] Calado, S. & Neves, I. P. (2012). Currículo e manuais escolares em contexto de flexibilidade curricular: Estudo de processos de recontextualização. *Revista Portuguesa de Educação*, 25 (1): 53-93.
- [12] Duarte, J. B. (2010). Manual escolar: Companheiro do jovem na aquisição de competências e na curiosidade pelo saber. *Revista Lusófona de Educação*, 16: 119-130.

- [13] Matias, O. & Martins, P. (2007). *Biologia 10/11. Biologia e Geologia. Ensino Secundário*. Porto: Areal Editores.
- [14] Silva, A. D., Mesquita, A. F., Gramaxo, F., Santos, M. E., Baldaia, L. & Félix, J. M. (2012). *Terra, Universo de Vida. Biologia e Geologia 10º ano*. Porto: Porto Editora.
- [15] Aires, L. (2011). *Paradigma qualitativo e práticas de investigação educacional*. Lisboa: Universidade Aberta.
- [16] Lessard-Hérbert, M., Goyette, G. & Boutin, G. (1994). *Investigação qualitativa: Fundamentos e práticas*. Lisboa: Instituto Piaget.
- [17] Carvalho, M. da G. S. P. (2010). *O manual escolar como objeto de design*. (Volume I). Dissertação de doutoramento, Faculdade de Arquitetura - Universidade Técnica de Lisboa. Lisboa.
- [18] Costa, T. A. M. (2011). *O texto expositivo num manual escolar de estudo do meio*. Tese de Mestrado. Escola superior de educação de lisboa - Instituto Politécnico de Lisboa. Lisboa.
- 
-

**Abstracts of other Works presented at the 12th  
International Conference on Hands-on Science.  
Brightening our Future, Funchal, Portugal, July 27-30,  
2015. [www.hsci2015.info](http://www.hsci2015.info)**







## Designing Learning Scenarios with Robots for Hands-on Mathematics and Informatics Learning

E Fernandes  
University of Madeira, Portugal  
elsa@uma.pt

**Abstract.** *We will present final results of a project – Droide II – Robots in Mathematics and Informatics Education. Within this project we created and implemented learning scenarios for hands-on mathematics and informatics learning, in which robots had a central role. Using a qualitative methodology in data collection and data analyses we tried to understand how the use of robots, as mediating artefacts of learning, contributed to the production of meaning and learning of mathematics and informatics. We used as theoretical framework, Situated Learning and Activity Theory. Some interesting results have emerged from a three years project searching about teaching and learning mathematics and informatics, through a 'hands-on' project - robots in mathematics and informatics education.*

*Throughout the presentation of the six learning scenarios created in the project Droide II (The Possible Travel [1]; Making a Movie [2]; Robot Race [3], Droide Virtual [4], Robot Guide-Dog for a Blind Girl [5] and A Journey to the Earth's Core) - we will highlight several features, that emerged as important when designing learning scenarios with robots for hands-on learning mathematics and informatics.*

*We will also present some attributes of the learning that emerged from the implementation of the learning scenarios with robots [6]*

**Keywords.** Robots, Learning Scenarios, Learning Mathematics, Learning Informatics.

### References

[1] Fernandes E. The Emergence Of Agency In A Mathematics Class With Robots. In: Proceedings of the Working Group 10. Cerme 8. The 8th Conference of European Research on Mathematics Education; 2013 Feb 6 - 10; Antalya, Turkey: Starlight Convention Center, Thalasso & Spa Hotel;

2013. p. 1725-1734.

- [2] Martins S. 'Regime of competence' in a school practice with robots. In: Proceedings of the Working Group 10. Cerme 8. The 8th Conference of European Research on Mathematics Education; 2013 Feb 6 - 10; Antalya, Turkey: Starlight Convention Center, Thalasso & Spa Hotel; 2013. p. 1774-1783.
- [3] Lopes PC. Racing with robots. In: Proceedings of 6th International Technology, Education and Development Conference; 2012 Mar 5 – 7; Valencia, Spain: Melia Valencia; 2012. p. 6217-6221.
- [4] Santos A. Robots as Learning Mediators In a Virtual Community of Practice. In: Proceedings of 6th International Technology, Education and Development Conference; 2012 Mar 5 – 7; Valencia, Spain: Melia Valencia; 2012. p. 6222-6225.
- [5] Abrantes P, Matos JF. "Using Activity Theory to understand how using robots can foster learning of basic concepts of programming". In: Proceedings of 6th International Technology, Education and Development Conference; 2012 Mar 5 – 7; Valencia, Spain: Melia Valencia; 2012. p. 299-305.
- [6] E Fernandes, editor. Aprender Matemática e Informática com Robots. Funchal: Universidade da Madeira; 2013. [www.cee.uma.pt/droide2/ebook/index.html](http://www.cee.uma.pt/droide2/ebook/index.html)
- 
-

## Light and Shadows of Hands-on Based Education

A Kazachkov<sup>1</sup>, M Kireš<sup>2</sup>

<sup>1</sup>V.Karazin Kharkiv National University,  
Ukraine

<sup>2</sup>P.J.Šafarik University, Slovakia  
akazachkov@yahoo.com,  
marian.kires@upjs.sk

**Abstract.** Efficient practicing of hands-on inquiry-based learning is barely possible without the teachers' concern about the attractiveness of the educational research, performed either in the class or during the extra-curricular projects. It is highly desirable for the students to stay interested and focused all through their inquiry. The very first acquaintance with the phenomenon or an object to be studied must induce students' questions revealing their curiosity, to be transformed into the desire to solve an intriguing experimental problem [1]. Strategy of the following research must provide for the thoroughly reasonable timing which will keep students staying tuned to the class activity or a project. Equally importantly, the outcome of an inquiry must let the students feel rewarded for their creative effort. Excessively routinized or/and time-consuming research may provoke students not to complete it, while a trivial or an uncertain result will cause disappointment with all the negative didactical consequences. On the other hand, an exceedingly entertaining informal science activity may be enjoyable for the students but with hardly any additional didactical value at all, literally a waste of time educationally. Thus, the choice of the adequate topics of the students' educational research is the key to the success of the IBSE practice.

Light phenomena provide for an abundant field of the enjoyable creative students' research with an enormous educational outcome. Corresponding activities may range from observations of the intriguing interplay of sunlight reflections and shadows to the intricate laboratory investigations. We review several practiced projects of the sort that combine outdoor observations and hands-on experimentation with light phenomena using low-cost conventional equipment and materials. Double shadows, multiple reflections, superlattice moiré patterns, unusual light-guides, an original CD/DVD model of the

rainbow, optical applications of the focal properties of ellipses and other exciting topics have proved to be of a true educational value. Computer modelling is a natural part of the presented activities and is combined with the ruler-and-pencil drawings to justify suggested explanations and to search for the new phenomena to be observed live.

**Keywords.** IBSE, efficiency of education, creative observations, hands-on projects, light phenomena.

### References

- [1] Inquiry and the National Science Education Standards: a guide for teaching and learning. Washington D.C.: National Academy Press; 2000.

---

---

## Chromium: the Keyword Towards a Web of Interdisciplinary Networks

ML Pereira, TM Santos  
University of Aveiro, Portugal  
mlourdespereira@ua.pt, teresa@ua.pt

**Abstract.** Finding studying topics able to promote the interplay of different disciplines to which students usually devote separate mental compartments are extremely useful once they can be explored in a wider perspective. As every "knowledge" is part of a whole global learning, as well as scientific literacy, any tool enabling to link different subjects is always desirable and can be looked at as a kind of a "bless" if it manages to motivate and reach students' learning.

The chemical element "chromium" is the main theme to be studied in the present work and it is used as a "case study". Chromium has been considered and classified as an essential element for over 50 years, due to its (possible) important role in living systems [1]. However, its classification also as toxic and carcinogenic gives him a dual behaviour providing a great example and interest mainly in terms of biology and chemical education. Further-more, it can be easily enlarged in order to reach many other fields of knowledge, even some less expected.

The identification of the biological functions associated to different elements became one of the fundamental aspects for research in recent life sciences. Additionally, extraordinary advances in these research fields arose in chemistry, biochemistry, pharmacology and medicine.

Chromium has a paradigmatic role in the possibilities to explore interfaces in a wide variety of other sciences, although biology and chemistry appear the most evident. Moreover chromium can be used and discussed from the basic (2<sup>nd</sup> cycle) to the higher levels (3<sup>rd</sup> cycle and secondary school - 10<sup>th</sup> and 12<sup>th</sup> school years).

In this work some examples of topics and branches of sciences which easily can share the keyword "chromium", are presented and described below.

Then we have chosen some examples to establish connections, such as "Essentiality": definition and exploration of why some elements are essential to life - Biology; "Dependence on the oxidation state": analysis of the elements location in the periodic table (transition metals) and their resulting chemical properties - Chemistry; "Required amounts of the elements to living systems" (bulk or trace elements) - Nutrition; "Justification of essentiality": inorganic coordination compounds (GTF and LMWCr) [2] - Inorganic and Coordination Chemistry; "Cellular metabolism of chromium": Biochemistry / Cell Biology; "Historical perspective" of the evolution of the concept of essentiality and evidence of this essentiality for chromium - History of Chemistry; "Pathologies associated with chromium deficiency" (diabetes and lipid metabolic problems) [3] - Medicine / Pharmacology; "Natural products or drugs containing chromium" (tris-picolinate-Cr<sup>III</sup>) [4] - Pharmacology/Industry of food supplements; "Controversy about the safe use of these supplements", as contradictory research results have been lately published - Public Health / Pharmaceutical Industry / Cutting-edge biometabolomics research; "Toxicity of Cr<sup>VI</sup>": strong oxidant - Chemistry; "Industrial uses" (chrome plating, leather processing) - Pollution; "Waste treatment": Environmental sciences; "Illnesses" [5, 6] (lung and skin cancer, dermatitis) - Epidemiology; "Movie scripts" (Erin Brokovich) [7] - Cinema; "Enlargement of the world markets" (China, North Africa and other

emerging economies) - Economy.

This work will present, by means of graphic tools [8, 9], some possible interdisciplinary relationships to be established departing from the word "chromium" and their implications in many different disciplines in a wide scope of knowledge. It is intended, therefore, to promote, in an appellative way, the scientific nature of learning, the general cultural skills and even civic education. Besides that, another aim of work is to improve, in students from various degrees of school development, skills of trans-disciplinary competences.

**Keywords.** Chromium, biology chemistry pharmaceutic and medical sciences, nutrition supplements, industrial applications and environmental pollution, interdisciplinarity.

### Acknowledgements

Thanks to CICECO - Aveiro Institute of Materials FCOMP - 01-0124-FEDER - 037271 (FCT-Pest-C/CTM/ LA0011/2013) and Chemistry Department, University of Aveiro, Portugal.

### References

- [1] Vincent JB. Chromium: Celebrating 50 years as an Essential Element? Dalton Transactions 2010; 39: 3787-3794.
- [2] Vincent J, editor. The Nutritional Biochemistry of Chromium(III). Amsterdam: Elsevier; 1<sup>st</sup> ed. 2007.
- [3] Levina A, Lay PA. Metal-based Anti-diabetic Drugs: Advances and Challenges. Dalton Transactions 2011; 40: 11675-86.
- [4] Nguyen A, Mulyani I, Levina A, Lay PA. Reactivity of Chromium(III) Nutritional Supplements in Biological Media: An X-Ray Absorption Spectroscopic Study. Inorganic Chemistry 2008; 47(10): 4299-4309.
- [5] Linos A, Petralias A, Christophi C, Christoforidou E, Kouroutou P, Stolidis M, Veloudaki A, Tzala E, Makris K, Karagas M. Oral Ingestion of Hexavalent Chromium Through Drinking Water and Cancer Mortality in an Industrial Area of Greece - An Ecological Study. Environmental Health 2011; 10: 50 doi:10.1186/1476-069X-10-50.

- [6] Gaggelli E, Berti F, D'Amelio N, Gaggelli N, Valensin G, Bovalini L, Paffetti A, Trabalzini A. Metabolic Pathways of Carcinogenic Chromium. *Environmental Health Perspectives* 2002; 110, supplement 5: 733-8.
- [7] <http://vidadeumaborderline.blogspot.pt/2013/05/erin-brockovich-uma-mulher-de-talento.html> Filme) [visited 11-June-2015]
- [8] Santos TM, Ferreira BJ. Coordination Chemistry: a bridge over troubled waters in a wonderful world (or not so ...), Abstract Book of the 5th EuCheMS; 2014 August 31- September 4; Istanbul, Turkey; 2014. p-B2-001.
- [9] Santos TM. alunos da UC "Química Inorgânica II" – 2014/15 "Nuvens de palavras": utilização de palavras-chave para interligar conteúdos – Resultados preliminares de um Estudo de Caso, Teaching Day, Culturas e Ambientes de Aprendizagem na Universidade de Aveiro, 3ª edição, 3rd December 2014, Aveiro, Portugal.

School Krsko. Literally, we brought the air into the classroom. One year and a half we spent designing, drawing and making by hand primary parts of the equipment. We encountered many problems with shortage of tools, equipment, materials, technology processing of materials and particularly with space. With all these problems, students learned a lot.

Only then did we begin to learn something about aerodynamic physics. The project is an opportunity for students to use different sensors and IT technology. They can develop sophisticated measurements and methods, hardware and software components and solutions in order to exercise their engineering skills. During this process, they learned a lot of science and physics.

- At the start we set some goals. We were looking for answers to the following questions and to complete the following tasks:  
Determine the optimal measure of laboratory wind tunnel.
- Select materials for construction.
- Dimensioning drive air flow.
- Decide how to ensure a steady continual distribution of air flow through the section of the wind tunnel.
- Identify the method of measuring air velocity in the device.
- Try out some of the old methods of measuring, which are based on a change in pressure.
- Establish measurement with digital anemometer (Vernier).
- Establish a mechanism for transmitting the measurement for forces in two coordinates.
- The measurement forces in x-y with digital sensors.
- Computer data processing (Logger Pro).
- Find the technology to see the wind lines.
- Design and construct in the program SketchUp.

---

---

## Wind Tunnel in the Classroom

*J Pernar*

*School Centre Krsko – Sevnica  
High School Krsko, CKZ 131, Slovenia  
Joze.pernar@guest.arnes.si*

**Abstract.** The absence of experimental work for students in all forms of science particularly in physics education brings about the loss of motivation and prevents deep understanding of real world phenomena. Combining natural phenomena and work in the classroom presents a considerable challenge for teachers and students alike.

Wind tunnels are an important form of testing and measurement for industry and laboratory research. That form of testing is essential in the automotive and aerospace industries, as well as for observing birds and some other physical bodies.

Building Wind tunnels brings fresh air into experimental education taking place at High

To download the main information about the model (car, plane, bolides, aerodynamic body) in a measurable value, we need sensors, which get certain information. These are then empirically evaluated and determine the appropriate physical coefficients. Our system was designed to measure forces in two coordinates. The vertical component  $F_y$  represents the lift force or pressure (low pressure), a force component  $F_x$  represents the resistance force of the object (model) in a fluid (air). The measured data are transferred to the table and representation graphical of physical quantities. By making careful measurements of the forces on the model, the students can predict the forces on the full scale of models.

All the work with wind tunnels in the classroom goes in two primary directions. The first is the regular course of instruction. In that part students can carry out experimental exercises. Even like didactic material for graduation. The other direction is research, where students can find unlimited possibilities for their development and release (explore?) ideas.

We measure with a laboratory wind tunnel some physical phenomena: basic measurements (speed of air, changes of voltage engine, volume flow, dependence of current and voltage drive...), forces on airplane wing, resistance to air models, streamlines in chamber, pressure and velocity on the wing, Venturi effect, Doppler effect, effect of pitot tube.

A wind tunnel is open and draws air from outside the tunnel into the test chamber and then pushes it back outside. In the future we wish to upgrade the tunnel to a closed system with the air recirculating inside the tunnel.

For physics and area of aerodynamics we currently have access to many computer programs with animations and simulations. And what are the advantages of using the wind tunnel before animations?

Direct handmade work with models, adjusting sensors, settings and measurement protocols of work offer students an extra dimension and additional cognitive perceptions for physical problems.

In other words, with direct measurements, observation and perception of changes in the

lab wind tunnel, we hope to acquire knowledge and arguments for a particular insight. These must be clear and concrete, to enable the students to come to suitable solutions and decisions.

Project page:

[http://www2.arnes.si/~sssksnm4/vetrovnik\\_ang/index.html](http://www2.arnes.si/~sssksnm4/vetrovnik_ang/index.html)

**Keywords.** Wind tunnel, aerodynamic, forces, lift, drag, sensors, models, physics experiments, measurement.

### References

- [1] Giancoli DC. Physics Principles with Applications, Sixth Edition. Person Education, Ltd., London; 2005.
  - [2] Koser J. Teorija letenja. Ljudska tehnika Slovenije, Triglavse tiskarne, Kranj, Ljubljana; 1949.
  - [3] Laurel. Educational Wind Tunnel, 9580 Washington Boulevard Laurel, Maryland. [www.aerolab.com](http://www.aerolab.com) [visited 12-August-2014]
  - [4] Hagishima A, Tanimoto J, Nagayama K, Meno S. 2009 Aerodynamic Parameters of Regular Arrays of Rectangular Blocks with Various Gemetries. Boundary-Layer Meteorol 132:315-337.
  - [5] NATIONAL AERONAUTICS AND SPACE ADMINISTRATION, Wind Tunnel Index. <http://www.grc.nasa.gov/WWW/K-12/airplane/shortt.html> [visited 10-Oct-2014]
- 
-



## A Study on Teachers' Perception about Educational Technology

C Serdar, E Ceylan  
Technology and Design Educators  
Association, Adana, Turkey

### Introduction

Changes in technology have influenced the education profoundly. Weiss and the others (1999) stated that pupils have to learn how to learn, how to think and how to use the necessary technology for them and they have to be educated accordingly. Most of the educators and researchers have reached a consensus that educational technology used efficiently has the potential of fostering education system (Cagiltay, Cakiroglu, Cagiltay ve Cakiroglu,2001). Efficient learning in classroom can be possible when the interaction between pupil-teacher, pupil-pupil, pupil-content and pupil-environment are at high level (Anderson,2003). In order to get high efficiency from these interactions teachers should benefit from educational technology (Ulas ve Ozan,2010).

The role of teacher has changed in our education system. A teacher is a counselor who shows the pupils how they reach the knowledge rather than transforms it. Teachers have to know how to use technology in accordance with the innovations in education process in order to counsel the pupils in teaching-learning process (Usun, 2006).As a result, they will raise a generation who follows and adapts to innovations in technology. Akkoyunlu (2002) stated that technology has an important role in education. For this reason teachers need combine their field topics with technology. But teachers' education on technology is still a problematic issue. Researchers think that technology need to be used as a tool rather than a goal in education (Strudler ve Wetzler, 1999). However, it is supposed that only knowledge and skill are acquired in the in-service training prepared by Ministry of Education. As a result, teachers don't know how and where to use technology.

Koehler and Mishra(2005) stated that teachers have to know about technology, pedagogy and content (Technology, Pedagogy and Content Knowledge, TPACK) in order to use technology in education.

Teachers' experience, decisions, approaches, belief and attitudes have influence on their use of technology in education (Cagiltay and the others). It will be useful to identify teachers' perception about educational technology in order to develop strategies about integration of technology with education.

Having all these in mind, our aim is 'Studying Teachers' Perception about Educational Technology'.

### Method

Target population of the study is teachers working in centrum of Adana in 2015 academic year. From this population samples are chosen through criterion sampling. According to Buyukozturk and the others (2008) in a research observation units are made up of people, events, objects or situations having particular features. In this case units (objects, events, etc) meeting the criterion for sample are taken into sample. From this point of view, criterion for the sample is teachers working in the schools having smart boards. According to this, the sample of the study is 50 teachers working in the schools having smart boards in the centrum of Adana.

**Keywords.** Educational Technology, Technology, Teacher.

### Bibliography

- [1] Akkoyunlu B. (2002). "Educational Technology in Turkey: Past, Present And Future". *Educational Media International*, 39 (2), 165-174.
- [2] Anderson T. (2003). "Getting The Mix Right Again: An Updated And Theoretical Rationale for Interaction". *The International Review of Research in Open and Distance Learning*, 4 (2).
- [3] Büyüköztürk Ş, Çakmak EK, Akgün ÖE, Karadeniz Ş, ve Demirel F. (2008). *Bilimsel Araştırma Yöntemleri*, Ankara: PegemA.
- [4] Çağiltay K, Çakiroğlu J, Çağiltay N, ve Çakiroğlu E. (2001). "Öğretimde Bilgisayar Kullanımına İlişkin, Öğretmen Görüşleri". *Hacettepe Üniversitesi Eğitim Fakültesi Dergisi*, 21, 19-28.
- [5] Koehler MJ, Mishra P. (2005). What happens when teachers design educational

technology? The development of technological pedagogical content knowledge. J. Educational Computing Research, 32(2), 131-152.

- [6] Strudler NB, Wetzel K. (1999). Lessons from exemplary colleges of education: factors affecting technology integration in preservice programs. Educational Technology Research and Development, 47(4), 63-81.
- [7] Ulaş AH, Ozan C. (2010). "Sınıf Öğretmenlerinin Eğitim Teknolojileri Açısından Yeterlilik Düzeyi?". *Atatürk Üniversitesi Sosyal Bilimler Enstitüsü Dergisi*, 14 (1), 63-84.
- [8] Uşun S. (2006). *Öğretim Teknolojileri Ve Materyal Tasarımı*. Ankara: Nobel Yayın Dağıtım.
- [9] Weis Allan, ve diğerleri H. (1999). Professional Development: A Link To Better Learning. School, Technology and Readiness Report, The CEO Forum, Washington.

PNSACV has an extension of 130 km including in the municipalities of Sines, Odemira, Aljezur and Vila do Bispo.

The "recreational fishing" it is part of the tradition of the people living in these near municipalities, having inherited a taste for rock fishing and shell fishing of their ancestors.

They are deprived of a moment's notice based on a law without being heard, without anyone to defend the tradition inculcated in each. In this park, since 2006, with the first law (868/2006) several fishing management measures have been implemented like, limitations and prohibitions without studies and licenses based on dissuasive law.

In practice, the process was reversed. What should be awareness and public participation became a force against the will of the people.

The another law (143/2009) for de PNSACV area it's even more restrictive, separating the principle of equality between nationals and resident people in PNSACV, compared to the law (144/2009) for the entire national territory.

In 868/2006:

- it was not allowed to collect seafood with any instruments;
- it is not allowed to use bait;
- maximum weight of 10 kg of fish/day; maximum weight of 500 grams barnacles;
- night fishing was not allowed.

In 143/2009 law, the days for recreational fishing were reduced (Thursday - Sunday and Holidays); New interdiction zones were created; The maximum total weight of fish/day was reduce; It was created a closed period for sea bream (01 January to 31 March); The collect of barnacles until 1 kg, was allowed only to recreational angler license holders who are natural or residents of the municipalities PNSACV; Night fishing was allowed only with life jacket use in PNSACV.

These restrictions were not accepted by the population who express their discontent in Sagres, Odemira, Vila Nova de Milfontes and the Assembly of the Republic in Lisbon. A working group was created and a law was changed revoked.

---

---

## Recreational Angler Management in Marine Protect Area: a Case Study of Top-bottom Management

F Encarnação<sup>1</sup>, S Seixas<sup>1,2</sup>

<sup>1</sup>Universidade Aberta, Lisboa, Portugal

<sup>2</sup>Universidade de Coimbra, Portugal

fencarnacao@gmail.com,

sonia.seixas@uab.pt

**Abstract.** This study is done in a natural park (Southwest Alentejo and Vicentine Coast Natural Park - PNSACV) a marine area with an extension of two km offshore all along its coastline (Marine Protected Area - MPA). The coast is composed of oceanic sandy beaches, extensive rocky shores, small estuaries and coastal bays.

The four MPA inside PNSACV, are Ilha do Pessegueiro and Cabo Sardão in Southwest Alentejo, Vale do Homem and Ilhotes do Martinhal in Vicentine Coast. The

Currently, the most relevant restrictive measures are the “false” temporal limitation to catch sea bream, because it’s only effective for rock angler; Established minimum sizes and weight maximums for marine organisms like, crustaceans, bivalves, gastropods, mollusks and fish; Angler fishing licenses are required.

Finally studies of the evaluation of MPA are made, but only in two of the four MPA covered certain species, without any restrictive measures.

Populations and commissions were heard and the scientific community begin working with the anglers in some studies. All should have been started here.

**Keywords.** Marine protect area, recreational fishing, angler, marine organisms, restrictive measures, rock fishing, Southwest Alentejo and Vicentine Coast Natural Par.

of inquiry-based learning, and provide clues for guiding and scaffolding the process. Students need structural support for developing their inquiry skills, therefore we set out to test an online (mobile) platform, that allows designers to structure the IBL process in a very flexible way. A review study on mobile inquiry based learning designs showed that mobile task support (ranging from dynamic lesson plans, to scripting for the entire inquiry learning process), by itself, can support a diversity of first- and second order effects (e.g. improved enjoyment, improved insight, and critical thinking skills). Through this study we aimed to learn more about the optimal level of structure. What would be the effect of structuring the student’s inquiries according to the 6 phase weSPOT model, the weSPOT activity structure, and making use of a mobile tool to support the process.

We present an analysis of the use of weSPOT project platform, with 155 school students from HAVO and VWO levels (ages 11-16), working in groups of 3/4. In the context of the food-week at the school, the students used the weSPOT platform with these three variations: 1) without following the six-phase IBL model developed in the project, 2) following the six-phase IBL model and 3) following the model, but also using the mobile app Personal Inquiry Manager as an application to extend data collection tasks outside of school and to afford mobile prompting. We wanted to know the level of engagement of students with the supporting task (activity widgets). Additionally we wanted to know the effect on cognitive load, and we expected to see the experimental group demonstrate deeper scientific understanding and more personally relevant learning, as they could tie their knowledge to their everyday experiences.

We found that students were not engaging with the task-structure to the level we had expected. The data from the platforms’ log show that students didn’t perform all the tasks in the environment and they tend to skip tasks. 73% of the contributions were provided in the first phase of the inquiry, the five other phases got barely any attention. Preliminary field data revealed that students felt lost during the intervention; they didn’t understand why all these small tasks were needed in coming up with a solution for their questions. The field data also suggest that students do not focus on

---

---

## Structuring Students Engagement in Inquiry-based Learning; the Process Is the Product

*A Suarez, F Prinsen, O Firssova,  
M Specht*

*Open University of the Netherlands,  
The Netherlands*

*angel.suarez@ou.nl, fleur.prinsen@ou.nl,  
olga.firssova@ou.nl, marcus.specht@ou.nl*

**Abstract.** In light of the current policy, a research focus on new forms of STEM learning has been defined on the European Commission (EC) and on national agendas. Inquiry-based learning is suggested as an efficient approach for propagating the practice of scientific inquiry and sparking student’s curiosity by linking everyday day life phenomena with science teaching in schools.

Process guidance and scaffolding are considered to be a necessity by most researchers in the field of (mobile) inquiry-based learning (Suarez, Prinsen, Kalz & Specht, 2015). Hmelo-silver, Duncan and Chinn (2007) lay out some of the complexities

IBL as a process, they were mostly working according to their custom, going straight to work on developing their final presentation.

Our findings encourage us to investigate plausible solution to cope with this lack of engagement. Support strategies for the division of labour, and making the inquiry tasks meaningful to students will be addressed in further interventions. Also, learning process analytics may help focus students on the IBL process; providing students with more contextual information may allow students to better understand the essence of inquiry-based learning.

**Keywords.** Division of labour, engagement, Inquiry-based Learning, mobile technology.

## References

- [1] Hmelo-Silver CE, Duncan RG, Chinn CA. Scaffolding and achievement in problem-based and inquiry learning: A response to Kirschner, Sweller, and Clark. *Educational Psychologist* 2006, 42(2), 99-107.
- [2] Suarez A, Prinsen F, Kalz M, Specht M. A review of Mobile Inquiry-based Learning designs and their effects. Submitted.

---

---

## Dependence of Fluorescence on Temperature

*B Mota, S Ferreira-Teixeira*  
*University of Porto, Portugal*  
*barbaraverse@gmail.com,*  
*sofialuisaft@gmail.com*

**Abstract.** For HSCI 2015 we bring a project based on our work developed in Physics Laboratory III, a subject of Bachelor's degree in Physics of Faculty of Sciences of University of Porto. During the semester we built an experimental setup to study how fluorescence of ruthenium samples is affected by a change in temperature. Later we challenged ourselves to reinvent our project in order to teach people of all ages and backgrounds about light, fluorescence and ways of detecting light. And thus, we took part in the Sciences Fair: "À descoberta da luz" where we won the first prize

in our category.

## Experiment and Results

We set up an experiment that allowed us to study changes in ruthenium's fluorescence with temperature varying between 14°C and 60°C. By using a LED ( $\lambda \sim 400$  nm) we made ruthenium fluoresce with maximum intensity at a wavelength  $\lambda = (596 \pm 4)$  nm. A spectrometer was used to obtain spectra of this fluorescent light. We observed a decrease in intensity as the temperature increased. However, the wavelength corresponding to the maximum intensity was shown to be independent of the temperature in the range of temperature studied. Furthermore, the spectrum of fluorescence got wider with higher temperatures.

## What is fluorescence?

If we irradiate some materials with an appropriate light, they emit light as a response. This is a process called photoluminescence. Fluorescence is a type of photoluminescence that has an almost instantaneous response ( $\Delta t \sim ns$ ) to an excitation light, ceasing in its absence. The incident light is absorbed by the material, exciting electrons to higher levels of energy. After a transition to an intermediate level of energy, the electrons return to the ground level emitting photons with energy equal to the difference between the last two energetic levels. That explains why fluorescent light always has less energy than the excitation light.

We see fluorescence in crystals and even in some animals and plants. It is also used in bills and decoration.

Studying how these processes happen is a way of understanding atomic properties of materials. Therefore, the study of the effect of temperature on fluorescence gives a deeper knowledge of solids and their optical properties.

## Presentation

Our participation in HSCI 2015 has two goals.

First, we seek to teach our audience about fluorescence: why it happens, how it is produced and how we detect it. There will be a poster containing this information. On the other hand, we will show various examples of

fluorescence, recurring to optical devices such as LASER pointers, a spectrometer, and optical fibers. Visitors will have the chance to interact directly with our experiments.

Secondly, we will present our study of the dependence of fluorescence on temperature, explaining the theoretical backgrounds and details of our experiment. We will be supported by a poster illustrating the experiment and its results.

**Keywords.** Fluorescence, Photoluminescence, Optical Devices, Temperature.

## References

- [1] Fox M. (2001). *Optical Properties of Solids*. Great Britain. Oxford University Press.
- [2] Jorge PA. (2006). *Luminescence Based Optical Fiber Systems for Biochemical Sensing Applications*. Porto. PhD Thesis.
- [3] Jorge PA, Caldas P, da Silva JE, Rosa CC, Oliva AG, Santos JL, Farahi F. (2005). *Luminescence-based optical fiber chemical sensors*. *Fiber and Integrated Optics*, 24(3-4), 201-225.

seem enough to understand all of the coastal erosion phenomena that have occurred. In a time when scientific community debates on the problems and causes of the erosion of the Northwest Portuguese coast [2], it seems important to make this information available to all citizens.

Rivers sediments should be transported to the continental shelf, but instead they are retained in the dams and although specialists refer this phenomenon as responsible for causing an enormous impact on erosion [1], it is one of the less public-known causes. This project pretends to contribute to an overall citizen enlightenment by developing a television-documentary broadcasted on an open channel, based on a series of interviews held with seven scientists from several departments of the University of Aveiro, specialised in coastal erosion.

The documentary addresses the Portuguese coastal zone in general and specifically the coastal zone of Aveiro region and the hydrographical basin region of the Douro River [3]. This production belongs to Fábrica Ciência Viva Science Centre of Aveiro which is part of the University of Aveiro and “Ciência Viva”, the national network of science centres.

The main goals of the project are: identification of agents that originated the vulnerability of the Portuguese coastal territory; promotion of public understanding of erosion phenomena particularly among affected citizens; awareness about the causes and consequences of the identified problem; contribution to general understanding of possible solutions to adopt.

The project started with a documental research and observation, audio-visual material registration, accompanying of researchers during some of their field works and surveys for the interviews. The narrative structure starts with a presentation of the problem, followed by their causes, consequences and their groundings, and some case studies, ending with proposals of possible solutions. References and information sources are referred as well as some final considerations about the problem.

**Keywords.** Beach, coastal protection, erosion, documentary.

---

---

## Impact of Coastal Erosion in Portugal: Science Facts in a Television Documentary

S Barata<sup>1</sup>, M Serra<sup>1</sup>, P Pombo<sup>1,2</sup>

<sup>1</sup> *Fábrica Centro Ciência Viva de Aveiro, Portugal*

<sup>2</sup> *Universidade de Aveiro, Portugal*  
sofia.barata@ua.pt, miguelserra@ua.pt,  
ppombo@ua.pt

**Abstract.** In the winter of 2013/2014 portuguese coast was devastated by severe and continuous storms and highly energetic waves, being this problem part of the news items for the worst reasons. In the last few years, Portugal suffered a progressive advance of the sea, caused by a variety of factors, putting in danger the security of people and buildings [1].

The information provided by media does not

## Acknowledgments.

Sofia Barata is grateful for a research grant provided by Fundação para a Ciência e a Tecnologia (SFRH/BGCT/33819/2009) and for a scientific support by Carlos Daniel Borges Coelho, Departamento de Engenharia Civil da Universidade de Aveiro; Maria de Fátima Lopes Alves, Departamento de Ambiente e Ordenamento da Universidade de Aveiro; Paulo Alves da Silva, Departamento de Física da Universidade de Aveiro; Cristina Bernardes, Departamento de Geociências da Universidade de Aveiro; Paulo Baptista, Departamento de Geociências da Universidade de Aveiro, Filomena Martins, Departamento do Ambiente e Ordenamento Planeamento e Gestão de Zonas Costeiras e Marinhas.

## References

- [1] Simões SC, Pereira CA, Coelho CD, do Carmo JSA. (2013). Quebramares destacados: análises comparativas de eficiências de proteção na praia da vagueira. *Recursos Hídricos*, 34(2).
- [2] Conceição TEdC. Impacto das acções antropogénicas no comportamento sedimentar do rio Douro; 2008.
- [3] Ferreira Ó, Dias JA, Taborda R. (2008). Implications of sea-level rise for continental Portugal. *Journal of Coastal Research*, 317-324.

is Socrative, a free and intuitive web-based system [2], where the students can use their own smart phones, tablets, or laptops to respond through a range of question options, in groups or alone. Socrative is free, student access is simple, easy to set up and had a modern, intuitive interface [3]. For accessing Socrative, all students needed to do is to navigate to a URL using the browser on their mobile device and enter a designated room number. Additionally, the responses can be anonymous, providing a safe environment which is encouraging student to participate.

The aim of this study is to develop an attitude survey and investigate students' attitudes toward the usage of Socrative in physics classes. Two different classes of first year students having algebra based introductory physics courses participated into this research. Socrative was used in the courses of civil engineering (24 students) and molecular biology and genetics (26 students) classes to make formative feedback. These courses were 3 hours per week and the Socrative was used at the third hour of each course for about three months at the spring semester of the 2014-2015 academic year. The instructor initially introduced the topic using various teaching strategies then he used the Socrative to assess students' immediate understanding. Having an immediate feedback helped to inform the instructor of student understanding of the current content being taught and to conduct extra activities to increase students' understanding on the topic. Research indicates that addressing learning concepts quickly with immediate feedback is very effective for improving motivation and learning [4]. The Socrative was totally used eight weeks in both classes. This is a long enough time for students to develop an attitude toward the Socrative.

Along with demographic items the researchers developed a 27 item survey to reveal students attitudes toward Socrative. The survey have five dimensions; advantage, belief, engagement, usability and attitude. Further, it is a 1-5 Likert scale where "1" indicating completely negative and "5" indicating completely positive attitude. The items were picked up from previous surveys [5], [6], [7], [8] on Socrative and it was validated through expert views. Moreover, its internal consistency reliability coefficient, Cronbach's alpha, was

---

---

## Using Socrative in Physics Courses for Immediate Formative Feedback

*N Balta, A Kaya*  
*Canik Basari University, Samsun, Turkey*  
*nuribalta@basari.edu.tr,*  
*akaya@basari.edu.tr*

**Abstract.** One way to improve student performance on exams and create a more positive and active atmosphere in classrooms is to integrate student response systems technology [1]. Contemporary student response systems are web-based and provide various ways for the students to interact. One example



calculated as 0,95.

The results indicated that students have a slightly positive attitude toward Socrative. Moreover, there was a statistically significant difference between the attitudes of civil engineering and molecular biology and genetic students. The attitude of latter group was fewer, this case was because of the fact that their biology course instructor also used Socrative, however, for grading. Results also showed that there were no difference between the attitudes of males and females, and there were no correlation between the attitudes and students' physics first term grades. As a conclusion, firstly, this study proved that the survey developed can be used in assessing students' attitudes toward Socrative in future studies. Second, Socrative can be used in teaching or discussing physics by other instructors as a student response system.

**Keywords.** Attitude toward Socrative, formative assessment, student response system, teaching physics.

## References

- [1] Caldwell JE. "Clickers in the large classroom: current research and best-practice tips," CBE Life Sciences Education, vol. 6, no. 1, pp. 9–20; 2007.
- [2] www.socrative.com.
- [3] Liu DY, Taylor CE. (2013, September). Engaging students in large lectures of introductory biology and molecular biology service courses using student response systems. In Proceedings of The Australian Conference on Science and Mathematics Education (formerly UniServe Science Conference).
- [4] Schute VJ. (2008) Focus on Formative Feedback. Review of Educational Research, 78, 153-189.
- [5] Piatek R. (2014). Student Response System: Student Activation towards Better Learning in Large Classes A Practical Guide.  
[http://samf.ku.dk/pcs/english/forteachers/tlh\\_e/projects/Remi\\_Piatek\\_TLHE\\_Project.pdf](http://samf.ku.dk/pcs/english/forteachers/tlh_e/projects/Remi_Piatek_TLHE_Project.pdf) [visited 17-April-2015].
- [6] Awedh M, Mueen A, Zafar B, Manzoor U. (2014). Using Socrative and Smartphones

for the support of collaborative learning. International Journal on Integrating Technology in Education (IJITE) 3(4), 17-24.

- [7] Dervan P. (2014). Increasing in-class student engagement using Socrative (an online Student Response System). AISHE-J: The All Ireland Journal of Teaching and Learning in Higher Education, 6(3).
- [8] Méndez D, Slisko J. (2013). Software Socrative and smartphones as tools for implementation of basic processes of active physics learning in classroom: An initial feasibility study with prospective teachers. European J Of Physics Education, 4(2), 17-24.

---

---

## Science Motivation

JC António, CMJM Marques  
Agrupamento de Escolas do Bonfim,  
Portalegre, Portugal  
[jorge.antonio2007@gmail.com](mailto:jorge.antonio2007@gmail.com),  
[catarinamdjmarques@hotmail.com](mailto:catarinamdjmarques@hotmail.com)

**Abstract.** *“Sem pensamento, sem diálogo estruturado sobre o porquê das coisas, sem controvérsia, sem enigma, sem verdadeira experimentação, não há ciência nem educação científica.”*

José Mariano Gago

*“It is much more interesting to live not knowing things than having the answers that could be wrong. I have many approximated answers, possible believes and different degrees of certitude about many different subjects, but I am not absolutely sure about anything...”*

Richard P. Feynman

Science is a human activity as old as humanity itself. Science has been accumulating knowledge through time, enabling the increase of society life standards. Scientific knowledge can be build up in separate parts that connect to each other in an integrated way and it should be accessible to all in order to enable the formation of active and more enlightened

citizens, which are able to take decisions.

Astronomy is considered the most ancient science. Humanity got used to observe the Cosmos with admiration and curiosity, sometimes also with fear. Three principal motivations lead to astronomy development: survival, orientation at counting of the time. Galileo opened us the doors of the universe. With his discoveries and findings, in January 1610, he did establish the bases of science and that of the scientific method. However, today as before, we go on continuously searching for answers to old simple questions as: Who are we? Where did we come from? Where do we go to? Or even: are we alone in the universe?

### **Projects and Activities**

In order to understand these and other similar questions and to go on the search for answers it is necessary to have great curiosity, ability to criticize, engagement, perseverance, resilience and attitude. On modern societies the educative and scientific activities have utmost importance. It is necessary to captivate talents and integrate always more young people with the precedent generations and to disseminate knowledge to all citizens. School can, and must, promote the discovery of this path.

We present a set of experimental activities, projects and strategies that have as first objective to demonstrate the science development in the educational context, promoting the motivation and the participation of youngsters. Simple and easy executable experiments, made with everyday use materials as “sun clocks” and quadrants will be presented. Considering that 2015 is the International Year of Light, some experiments with light and the importance of its technological applications will be presented too.

They will be held construction practice sessions and use clouds chambers (Wilson chambers) for detection of cosmic rays: “Cloud Chamber Workshop”.

Nowadays it is unanimous that to consolidate the process of science learning it is decisive to give to students the possibility to make previsions, to discover, to experiment, to make errors and to look for solutions, to communicate, to share and develop skills at the collaborative work level. In summary, to use a “hands on” scientific spirit.

Science activities contribute to the development of these skills. Other activities that are relevant to the process and that have already demonstrate its efficacy on the teaching-learning process are:

- Measuring the length of a pencil shadow to determine solar mid-day;
- Observation of astronomical phenomena;
- Visits to science Museums and centers (ex: Ciência Viva – Science Centers in Portugal).
- Visits to large research facilities (ex: CERN - European Organization for Nuclear Research).
- Talks, Conferences, Seminars and workshops bringing scientists to school.
- Projects, concourses and competitions (Ex.ºs: Beam line for schools - CERN, Olympics –Physics, Astronomy, etc).

Some strategies to succeed with those objectives are:

- In classroom give space to students to exercise creativity and innovation;
- Dynamize Clubs (of science, astronomy, physics,...);
- Recognize merit giving regularly prizes to best students performances.

### **Acknowledgments**

To all students and teachers that were together with me through this odyssey and that teach me so much.

### **References**

- [1]<https://teachers.web.cern.ch/teachers/document/cloud-final.pdf>
- [2][www.tsf.pt/PaginaInicial/Portugal/Interior.aspx?content\\_id=4518596](http://www.tsf.pt/PaginaInicial/Portugal/Interior.aspx?content_id=4518596)
- [3] Feynman, Richard P. O Prazer da descoberta; 1.ª ed., Gradiva: Lisboa; 2006.
- [4] Carvalho JPM. Astronomia em tempos remotos. FC U. Porto; 2003.

## Access to Science and Technology by Women in India

*K Dasgupta-Misra, Vigyan Prasar  
Department of Science and Technology,  
Government of India  
New Delhi, India  
kdgm04@gmail.com*

**Abstract.** Despite efforts made by the countries to give women greater access to science and technology education, research shows negative results, particularly in the area of engineering, physics and computer science. A recent study of gender benchmarking by UNCSTD (2015), researchers found that number of women in the science and technology and innovative fields are alarmingly low in the world leading economies, and are actually on the decline in many including the United States.

India ranks lowest overall of the countries study – Brazil, South Africa, India, the Republic of Korea, Indonesia, US and the EU including low rankings in economic status, access to resources, knowledge economy and health.

While India's enabling policy environment, which has been in place for many years is positive, implementation and funding needs to increase substantially before women can equally benefit from the innovation advantage. There are definite signs of progress, India has achieved Universal primary education enrolment, increased uptake of STI Policy, the access to women in S&T can be ensured in India if the women are enabled and supported to improve their health, access to resources and opportunities, and develop capacity to contribute to India's knowledge society.

The immediate strategy to make some of the gap in science, mainstream women in science and technology, it is critical to measure the participation of women and girls in science and technology and innovation by identifying the strengths and weakness and form evidence based policy making.

In order to achieve the women parity in science, it is important that the science, technology, innovation, health care is integrated to multiple empowerment factor with the most influential being higher economic status, larger roles in government and policies,

decision making, access to economic, productive and technological resources, quality health care and financial resources.

The report of the Indian Academy of Science analyses and discusses several dimensions to consider with regard to issues about Indian women in science including the research and development, policies, decision making, overall environment, ethos, women's role and status in the society.

The paper would try to address upon the reasons for the gender disparity in science, the socio-cultural and economic factors, double or triple burden of home making, work outside home etc. which lead to women missing out more in science and technology. The paper would highlight the various enabling environment required to be created to encourage more women in science and remove the barriers to access and glass ceiling in science and technology. The paper would also address the various measures of encouraging women in science, promote more women in scientific research. The role model programmes and mentoring activities need to be strengthened to have access to women in science and technology through Information Communication and Technology (ICT).

ICTs do play an important role in disseminating a wide range of information and advice leading to knowledge and attitude change among rural communities. Most of the ICTs are disseminating new knowledge on agriculture, health and nutrition among rural women. It is also supporting rural communities to acquire new skills and is also creating new employment opportunities. However, the continuing digital divide between urban and rural areas and between men and women currently constrain the realization of the full potential of ICTs in reaching rural women.

ICT offer the opportunities for direct, interactive communication even by those who lack skills, who are illiterate, lack mobility and have little self-confidence.

While new information and knowledge is necessary, it is not sufficient to bring about women empowerment. To make use of the information, women would need access to other sources of support and services. Women who are part of other development initiatives or groups and those who have access to other

sources of service and support were able to better use the information and knowledge disseminated through ICTs.

The potential of ICT tools varied widely in reaching rural women. There is no ideal ICT that fits all situations. In most of the ICT initiatives that depend on internet kiosks, portals, call centres, mobile, video digital photography etc, there is not enough evidence to show its wider access and use by women.

Among the varied tools, the knowledge centres, mobile telephony and the community radio were found to have the greatest potential in reaching women with locally relevant content. In all cases, there is an explicit intention to target rural women.

Radio and television would still remain critical for disseminating a wide range of information to rural communities in India in the years to come. Increasing interactivity and more imaginative programming through interfacing with communities and listeners/viewer clubs/groups would enhance its contribution significantly. Radio and television also support distance education programmes to a very large extent.

There is a lot of potential for ICTs to create new employment opportunities for women in rural areas. Rural women however need financial, technical and managerial support to effectively utilize this opportunity. ICTs can also contribute significant gains in efficiency and effectiveness in rural women enterprises.

These tools and its applications are intended for the rural communities without any specific attention for women's special needs for information and their constraints in accessing these.

-Men are specifically targeted in these initiatives as they take decisions on inputs, farm operations, marketing, accessing government schemes etc.

-The information provided through these tools are generic and so while it adds to the information base of rural communities including women, its lack of contextualization prevents both men and women from using this information effectively.

-Lack of adequate research on women's

access to ICTs and the resultant lack of data, constraints any specific action that might be needed to improve women's access.

**Keywords.** Access, decision making, economic status, gender mainstreaming, health, innovation, knowledge society, policy, resources, STI policy, science and technology, Universal education policy, women empowerment.

## References

- [1] Science Career For Indian Women: An examination of Indian women's access to and retention in scientific careers. REPORT October 2004, Indian National Science Academy, New Delhi.
- [2] Gender equality and empowerment of women through ICT September 2005 UNITED NATIONS Division for the Advancement of Women Department of Economic and Social Affairs.

---

---

## Arduino Science Kit: Open Hardware Platform for Science Activities

*P Ferreira<sup>1,2</sup>, J Loureiro<sup>2,3</sup>*

<sup>1</sup>*ES de Santa Comba Dão*

<sup>2</sup>*ES de Tecnologia e Gestão, Instituto Politécnico de Viseu, Portugal*

<sup>3</sup>*Centro de Estudos em Educação, Tecnologias e Saúde, Viseu, Portugal*  
*pjferreira@hotmail.com,*  
*jloureiro@estv.ipv.pt*

**Abstract.** Teaching in the information era is a challenge. Teachers face this challenge embracing the tools from the computer sciences, but students must be engaged. They no longer want to be a silent and passive part of the class. Science is the pursuit for knowledge and students must drive this chase.

For schools, the cost of the technological solutions is really expensive. One kit for science activities in physics will reach 1000 € for just one group [1]. The commercial solutions

[2][3], although very good, have another drawback: they all tend to be black boxes.

Teachers recognize the value of laboratorial activities and the use of the computer in the class room [4]. There are studies that show the impact of these activities on the student's results [5].

This work proposes an open platform based on the Arduino microprocessor that is cheaper and transparent, as long as the teacher wants it to be, while been accurate.

There are no closed long boxes in this platform and the components can be easily found, even in old toys, allowing students to be engaged in the lab apparatus, not just in using it, but also in building it. No matter the costs, there are some things that can't be in jeopardy and one of them is the results: they must be accurate or the solution won't have enough quality to be used.

Other authors have proposed the use of the Arduino platform [6][7] for the laboratorial activities in physics teaching. However, this project presents a different approach. The user won't have to reprogram the Arduino.

The ASKIT (Arduino Science Kit) includes a firmware for the Arduino that, once installed, will ensure the management of the sensors and the communication through a USB cable or a Bluetooth connection. The main purpose of this software is to process de requests from the computer and send the data collected from the input pins. If everything works as planned, the user won't have to think about it. The hardware is composed by an Arduino Uno R3 fitted with a Bluetooth chip. The Arduino is a microcontroller based on the ATmega328. The sensors are light dependent resistors, temperature sensors, an ultrasonic distance sensor and others.

The users will work with the Windows application that controls the Arduino by sending messages and receiving data. The data rate is really important in experiences like the free fall objects. With this platform it reaches one thousand samples per second. The ASKIT also includes an Android app that can work in conjunction with the Windows application. Both programs will allow the users to receive the data from the Arduino and work on the results produced by the sensors.

The tools available in the software include charts, to visually analyse the data, and regression tools, linear and exponential, to reveal trends in series of values.

The software has some laboratorial activities oriented options in order to allow the teacher to easily implement them. Activities like the free fall object, the bouncing ball and the inclined plane have their own options, with specific charts and equations. These activities will have an explanation of the physics principles, including the formulas that students will have to apply. The controlling application is ready to receive data from multiple Arduinos at once, so the teacher only needs one computer in the classroom to control all the experiments being executed by the students.

After the data is collected to the computer, the students can manipulate it and make their work, exporting the collected data and the created charts to allow them to make a report of the activity. There's going to be a functionality that will give the user the freedom to use the platform as an open playground to collect data from whatever sensors available in the Arduino and do the analysis he intends.

All the data is stored in XML, so that it is easily loaded into other applications like Microsoft Excel. This platform is an ongoing project for a Master Thesis of the Escola Superior de Tecnologia e Gestão de Viseu (MSTIO). The development tools are the Visual Studio 2013 Community for the Windows application, in C#, and the Android Studio for the Android app, in Java.

The development of this solution has contributions of physics teachers and will soon be tested with students in the classroom.

**Keywords.** Arduino, Android, Physics Lab Activities.

## References

- [1] Verney, "Kit Verney," 29-Dec-2014. [Online]. Available: <http://www.vernier.com/products/packages/physics/lq-mini/>. [Accessed: 29-Dec-2014].
- [2] Altay Scientific Group, "Altay." [Online]. Available: <http://www.altayscientific.com/en/home/>. [Accessed: 16-Dec-2014].

- [3] Pasco, "Pasco," *Pasco*, 2014. [Online]. Available: [www.pasco.com](http://www.pasco.com). [Accessed: 09-Dec-2014].
- [4] Fiolhais C, Trindade J. "Física no computador: o Computador como uma Ferramenta no Ensino e na Aprendizagem das Ciências Físicas," *Rev. Bras. Ensino Física*, vol. 25, no. 3, p. 259, 2003.
- [5] Oliveira F, Nascimento MA, Alberto HV, Formosinho S. "Ensino das Ciências Físico-Químicas: O Papel do Professor face à Diversidade Cultural dos Alunos," *Rev. Port. Pedagog.*, vol. Extra-Série, pp. 337–346, 2011.
- [6] Zachariadou K, Yiasemides K, Trougakos N. "A low-cost computer-controlled Arduino-based educational laboratory system for teaching the fundamentals of photovoltaic cells," *European Journal of Physics*, setembro-2012.
- [7] Souza AR, de Paixão AC, Uzêda DD, Dias MA, Duarte S, Amorim HS. "A placa Arduino: uma opção de baixo custo para experiências de física assistidas pelo PC," *Rev. Bras. Ensino Física*, vol. 33, no. 1, 2011.
- 
- 

## Potential of Science Club Networks for Science & Technology Popularization and Communication

*B Kumar-Tyagi, V Prasar*  
*Apeejay Stya University, Sohna*  
*(Haryana), India*  
*bktyagi@vigyanprasar.gov.in,*  
*tyagi.bk@gmail.com*

**Abstract.** The paper defines the dynamics of science clubs as robust platforms for communicating science and technology aligned with several local level considerations. This is in the context of the fact that people need to understand the pervasive nature of science and technology today more than ever before, as these two aspects influence all aspects of life. In all democratic forms of government an increasing number of people are involved in decision making at the local and the national level. Such scientific and technological issues as nuclear energy, global warming and climate change, preservation and conservation of biodiversity, genetically modified crops, etc., dominate the development mosaic and need to be debated before national policies are formulated. To generate meaningful and effective debate, the public needs to be well informed and updated on information so that informed decisions can be made. The debate should not remain confined among elite groups but emerge with the direct involvement of people from all walks of life. A robust decentralised approach to enhance public understanding of science and technology is therefore essential.

Currently, several approaches and media are tried with equal emphasis in developed and developing country contexts. Every form has its own significance, utility and limitations as well. Such institution as science museums, science cities, satellite and cable TV and radio, specialised agencies for S&T communication, and both government and non-governmental organisation play their role quite effectively in taking science to people. These approaches are however capital intensive and are based on the deficit model of S&T communication.

For example, India's manifold diversity including cultural, social, religious, linguistic and regional is unparalleled in the world.



Importantly nearly 65 % of population are rural and a significant part of the population is not literate. The reach of mass media, except radio, is still limited. These ground realities present a formidable challenge to a science communicator. In such a scenario, any centrally planned strategy employing modern means of communications does not stand much chances of success. Any strategy to be effective should be “participatory and in the local language through the familiar channels of communication”.

Across the world, a variety of science clubs and networks of science clubs are active. These clubs are supported by national governments and even such international bodies as the UNESCO. Some networks of science clubs have significantly long histories since beginning of nineteenth century. Some such networks of science clubs worth mentioning are from America, Canada, STEM clubs of UK, Federation of Young Farmers Clubs, VIPNET, and Eco-clubs in India. They have also supplemented formal science education under various circumstances. Their potential as decentralised centres of social transformation centred on S&T communication is concern is however yet to be explored.

Over the past decade, Vigyan Prasar, an autonomous institution of the Department of Science & Technology body of Government of India, attempted to involve all existing and newly-formed science clubs to create a network of these entities namely the VIPNET (Vigyan Prasar Network of Science Clubs). Initially the network members were motivated to take up scientific activities to help fulfil the goal of achieving a scientifically oriented and empowered society in the country. Presently about 12,000 clubs are involved from all States across the country. Members of the network have been involved in some of the major campaigns built around celestial event like solar eclipses, biodiversity, water, etc., that has proved the role the clubs can play in taking science to the people. These involved debates, surveys and demonstrations, performing experiments, and answering the queries of citizens at the local level. Over the years VIPNET club activities have been transformed essentially into people-oriented activities. They are not confined to formal classroom or laboratory experiments, nor do they provide any bookish or theoretical knowledge; rather

they invite and involve people to see, do and learn things by themselves and find out the truth. Science club activities have accordingly established a strong link between science and the community.

A decade of experience with science clubs and societies, including analyses of reasons for their survival or otherwise has shown that the members and functionaries of the clubs sometimes find it extremely difficult, after a couple of years, to sustain the zeal and excitement with which the clubs were formed. Either they lack new ideas or activities, or fall short of active members or minimum funds to carry on with anything meaningful and educative. A series of meetings and brainstorming sessions with clubs and stakeholders have resulted in the formulation of a road map for the science clubs movement.

The present paper highlights the basic philosophy, current status, and developments as a result of the literature survey, consultation meets and focus group interactions in recent past to sustain the zeal and excitement among the clubs so that they continue to act as centre of social transformation by creating much needed scientific outlook. These will be useful for initiatives in comparable circumstances to mainstream synergies across institutions and beneficiaries of science and technology communication interventions.

**Keywords.** Science Clubs, Science Popularisation Science Communication, VIPNET, Eco Clubs, Classical Club, Radical Club, Hybrid Club.

---

---

## SCIENTOONS and Nanotechnology: a Science of Small Things for a BIG Change

*PK Srivastava*

*Medicinal and Process Chemistry Division,  
Csir-Central Drug Research Institute,  
Lucknow-226031, India  
pkscdri@gmail.com*

One nanometer (nm) is one billionth, or  $10^{-9}$  of a meter. Materials reduced to the nano scale can suddenly show very different properties compared to what they exhibit on a macroscale, thus enabling unique applications. For instance, opaque substances become transparent (copper); inert materials become catalysts (platinum); stable materials turn combustible (aluminum); solids turn into liquids at room temperature (gold); insulators become conductors (silicon). Materials such as gold which is chemically inert at normal scales, can serve as a potent chemical catalyst at nanoscale. Nanotechnology matters because familiar materials begin to develop odd properties when they are of nano size. Tear a piece of aluminum into tiny strips and it will still behave like aluminum. But keep chopping them smaller and at some point that is 20-30 nanometer, this nonaluminium can explode and thus scientist are trying to use Nano aluminium as rocket fuel.

Nanotechnology could prove to be a "transformative" technology comparable in its impact to the steam engine in the 18th century, electricity in the 20th century, and the Internet in contemporary society. Nanotechnology is a field of applied science and technology covering a broad range of topics. The main unifying theme is the control of matter on a scale below 100 nanometers, as well as the fabrication of devices on this same length scale. Richard Feynman described the concept of 'building machines' atom by atom in his talk titled "There is plenty of room at the bottom". Top 10 use of nanotechnology include energy, water treatment, diagnosis of diseases, drug delivery, air pollution, construction material, health monitoring, pest control, agriculture and food processing. Microscopes have offered scientists a window inside cells. Yet, what scientists have not been able to do is to answer questions such as, "How many cells are involved in cancer?" "How big is the cancer?"

and "How fast a drug can be delivered at the exact place". The availability of innovative, body-friendly nanotools will help scientists how to build synthetic biological devices, such as miniature, implantable pumps for drug delivery or tiny sensors to scan presence of infectious agents or metabolic imbalances that could spell trouble for the body. In the treatment of brain tumour, laser guided smart bombs are used. Researcher at University of Michigan announced the testing of a drug delivery system that involves drug-toting nano particles and a guided peptide called F3. PHOTOFRIN a pharmaceutical which is photodynamic that means it can be activated by laser after it has entered in the blood stream to target cancerous cells of esophagus, bladder, skin and brain.

What is most important today is that people are not aware of the promises nanotechnology holds for the future especially for a country like India and other developing countries. This Scientoon based audiovisual technique is more useful when a scientific program is undertaken to make people understand and learn and thus create interest in that area for higher education/mass awareness. This paper is an attempt to show that how complex subjects of science can be presented and effectively explained using scientoons so that the science communication/education/research in these areas can be made more informative, effective, interesting and useful. Author who has started a novel concept of science communication called scientoon (a new class of cartoons based on science) and subsequently a new science called Scientoonics, will use this science to create awareness about Nanotechnology as what enormous future nanotechnology holds for us.

---

---

## Interdisciplinarity in Physics Education - Study of the Potential Difference Generated by Oxidation-Reduction Reaction (Battery) with the Use of Computer Modelling

Y Ulrich, A Machado, C Elias,  
A Santiago, L Pinheiro  
State University of Rio de Janeiro, Brazil  
yanulrich.uerj@gmail.com,  
alanfmac@gmail.com

**Abstract.** The goal of this paper is to describe a teaching and learning experience applied to a group of high school students, in the College Pedro II - Rio de Janeiro - Brazil, where the educational software "Modellus" was employed for making a simulation of the principle of operating of a battery using the process of redox between iron ( $\text{Fe}^{2+}$ ) and copper ( $\text{Cu}^{2+}$ ) in acid (citric acid).

Currently, in the technological age, one can observe a context that includes: technological innovations together with several lines of research, whose goals are to improve and develop educational software. These technologies are responsible for implementing shifts in the educational system, in order that teachers will explore the most of available technological resources for teaching, therefore these practices together with Technologies Innovation and Communication (ICT) moderns, they use virtually unrestricted and immediate access to the most diverse forms of information and knowledge through the internet, as a way to arouse the interest of students and possibly motivation.

Once enlightened the importance and benefits of the use of educational software, both for the students and teachers, one can start exploring the theoretical part necessary for the creation of this modeling. Battery Operating principle - chemical generator: part of redox reactions, where there is a reagent that tends to donate electrons (oxidation) and one reagent with a tendency to receive these electrons (reduction), phenomena occurring simultaneously, creating a flow of electrons. This battery is constituted by an iron plate connected by a wire to a copper plate, both immersed in lemon juice containing citric acid, which is responsible for releasing  $\text{H}^+$  ions, allowing formation of a conductive solution of a

blank for another, creating a potential difference which generates the passage of electrons recorded by a voltmeter coupled plates.

Now that students understand the workings of this type of battery is possible to create computational modeling - a process that can be done by the students, aided by teachers. Is used Modellus educational software, in which the equations, variables, and parameters are inserted, which serve both to describe the phenomenon as well as to create the required animations for the understanding described. Ready the modeling, students will have complete freedom to change some parameters and "real-time" perform qualitative and quantitative analysis in the system.

Thus the students had a theoretical and solid learning on the subject, they learned applications of electrochemistry and above all - they could observe and compare the results. By this deeper study, both the equations and the data obtained, the students could strengthen the correlations between several natural phenomena involved in modeling, favoring dialogism, cognition and benefiting them in the process of teaching and learning.

**Keywords.** educational software, redox reactions, battery, computational modeling, Modellus.

### References

- [1] Simões D, García F. A Pesquisa Científica com Língua e Práxis. Rio de Janeiro: Publicações Dialogarts; 2014.
- [2] Valente A. Computadores e Conhecimento: representando a educação. São Paulo; Gráfica Central UNICAMP; 1998.
- [3] Atkins P, Jones L. Princípios de Química: um questionamento a vida moderna e ao meio ambiente. Porto Alegre; Editora Bookman; 2006.

## "Ciência p'ra que te Quero": Making Science Accessible and Exciting to Young People

*MA Forjaz, M Maciel, A Alves,  
J Ferreira, J Marques,  
C Almeida-Aguiar, MJ Almeida  
Universidade do Minho, Portugal  
maf@math.uminho.pt,  
marina.costamaciel@gmail.com,  
Aida.Alves@blcs.pt, nebaum@gmail.com,  
cristina.aguiar@bio.uminho.pt,  
juditealmeida@bio.uminho.pt*

**Abstract.** In the last two decades science has delivered dramatic results relevant to health, survival and lifestyle. In many cases the pace of scientific change has accelerated beyond what the public can keep up with, fully understand and accept. Many people find scientific ideas difficult to apprehend - or simply do not see why they are important and how great their impacts are. For this reason, science communication is becoming an increasingly bigger and important area.

Experiment@Ciência is a science outreach project designed and implemented by maths and biology professors/ researchers of the School of Sciences (ECUM) of the Universidade do Minho, Braga, Portugal. This project has as main goal the development of different scientific and experimental interdisciplinary activities for public of different ages, trying to make science part of everyday life, bridging the gap between science and society and making science accessible and exciting to young people and non-scientists. This communication is devoted to "Ciência p'ra que te quero", one of the intervention fields of the Experiment@Ciência project, which consists of a set of experimental lab hands-on activities designed for children between 6 and 10 years old. These activities are planned and implemented in a partnership with a group association of undergraduate students enrolled in the degree of Applied Biology (AB) at Universidade do Minho – the "Núcleo de Estudantes de Biologia Aplicada da Universidade do Minho" (NEBAUM) and the library "Biblioteca Lúcio Craveiro da Silva" (BLCS), in Braga.

The mission of "Biblioteca Lúcio Craveiro da Silva" is to promote books, reading, facilitating

the access to information and knowledge to the surrounding community. BLCS encourages sharing of information and knowledge through cultural actions, promoting citizenship. The Library is committed with the development of actions that enhance information and scientific literacies, since it considers that learning science informally, concurrently researching information in books and on the Web are mandatory basic skills for all the citizens of today's world.

NEBAUM, the biology students' association of Universidade do Minho, who accepted the invitation of Experiment@Ciência to collaborate in "Ciência p'ra que te quero" as science communicating agents has, among others the goal of "promoting and collaborating in cultural and recreational actions related to the academic life." Strategically, NEBAUM develops experimental activities for younger audiences, in order to present the degree in Applied Biology.

Every 3<sup>rd</sup> Saturday mornings of each month, a different activity is organized at BLCS, allowing children to be in contact with different scientific interdisciplinary hands-on activities, and let them try to be scientists for two hours. The undergraduate students from NEBAUM have a special job as monitors supervising each of the different tasks that take place during the activity. At this moment, five activities were carried out about different subjects - (1) heart, (2) water, (3) green world, (4) growth of living beings and a (5) safe summer – but four more activities are already scheduled until the end of the year. Several questions were tried to be answered during such activities that include different lab tasks:

- (1) Beat beat heart - Do you want to learn more about your heart? And to know why and how this muscle beats? And learn how to build a graphic in a special paper, showing the rhythm of your heart when you're quiet or running?
- (2) H<sub>2</sub>O: water for life - Do you know in how many states can you find it on Earth? And how much water is available for life? How much water is there in your body? And how many liters do you waste daily? Have you heard about the water footprint? Do you want to learn how to calculate yours?
- (3) Green: mandatory to respect - Where does

the green of the plants come from? And why they change their colour? Do they breathe and have "noses"? And ... do you know what fractals are? Do you want to find them in nature? Do you want to make one?

- (4) Growth and multiply - Your body grows and so do other animals and plants. What means "growing"? Only living things grow? And our body grows respecting proportions? Would you want to measure and verify them? Some cells die and others born. Do they multiply? How long does a cell take to double? Is this double time the same in microbes, plants and animals? How trees and bushes arise? How do fruits arise from flowers?
- (5) Summer (with)science - Summer has arrived!... Have you already observed that your sweat is more abundant and frequent? Do you know why? Is it helpful to your body? It's beach time. Do you know how should you protect yourself? Do you want to design a beach towel with regular polygons?

The choice of the suggested tasks and activities was based on a set of criteria including the inclusion (or not!) of the themes in the 1<sup>st</sup> level of school national curricula, as well as the possibility that such subjects could be addressed with varying degrees of depth, depending on the grade and level of cognitive development of children.

To evaluate the project two kinds of surveys were taken in each activity: (a) for the children (b) and for the AB-monitors. Results obtained show not only the greater involvement of AB-monitors and children but also, and perhaps the main result, that the hands-on science learning activities can enhance children's learning effectiveness in scientific thinking and attitudes and promote science education and scientific literacy.

The present work will present the project "Ciência p'ra que te quero", the different activities promoted and some of the results of its implementation. With these activities we want to make science more attractive to young people and to increase society's appetite for scientific information and innovation, simultaneously gathering ideas to implement further research and innovation activities. At the same time, this kind of activities aim to answer some of the societal challenges tackled by

Horizon 2020, building capacities and developing innovative ways of connecting science to society and vice versa.

**Keywords.** Biology, Hands-on, Mathematics, Scientific literacy, Science communication.

---

---

## From Science to Consciousness: Why do We Need Clean Water

*MA Forjaz, MJ Almeida,  
M Maciel, A Nobre,  
C Almeida-Aguiar  
Universidade do Minho, Portugal  
maf@math.uminho.pt,  
juditealmeida@bio.uminho.pt,  
marina.costamaciel@gmail.com,  
anobre@bio.uminho.pt,  
cristina.aguiar@bio.uminho.pt,*

**Abstract.** The World Water Day, promoted by the UN, is celebrated annually on 22<sup>nd</sup> of March. The date aims to draw the world attention to the urgent need to preserve and save water, a valuable and increasingly scarce natural resource. In 2014, on behalf of the motto "Water and Energy ", the STOL project has considered important to reflect on water uses and to raise awareness towards a more rational use of this finite resource. With this goal, 17 illustrative artworks of a certain object and the correspondent Water Footprint (WF), translated in sets of bottles symbolizing the corresponding water volume, were strategically placed in several locations at Campus de Gualtar, Universidade do Minho (UMinho) and in Library Lúcio Craveiro da Silva (BLCS) in Braga.

The WF is an indicator of the direct and indirect use of fresh water by a consumer or a producer. The WF of an individual or an object is thus defined as the total volume of fresh water needed to produce goods and services consumed by the individual, or to produce the referred object. The value is usually high and causes some amazement and disbelief among non-specialized public.

The STOL initiative, included in the UN official website, was exhibited during eight days

and intended to sensitize the academic community and the BLCS customers for their involvement in reducing the WF of goods, and for a commitment to more sustainable water consumption. The artworks were designed taking into account the space where were placed, normally of great human turnout. Thus, a pair of sneakers and a training suit were hung in the Sports Pavilion, pictures of foods in the canteen; paper sheets and traditional recycled paper and mobile phones were placed at the General Library and BLCS; cups of coffee or chocolate boxes were suspended together near the Bars and computer keyboards appeared at computer centres/labs.

This action, initially thought to be conducted at a few places at UMinho, was immediately extended to other areas upon request of several services and units of the institution. Despite the difficulties in assessing the initiative, we can try to express its impact by estimating the number of individuals who have passed in such places, and by the instant success of the initiative and its echoes, which jumped the university walls and reached the regional press. Since then, several higher schools of the region are requesting the materials to reproduce the initiative in loco, to celebrate a multitude of events. In the present communication, a critical analysis of the initiative and its impacts will be performed.

**Keywords.** Water, Water Footprint, sustainable use, public awareness.

---

---

## **Science Communication from Undergraduate Students to Children: Activities, Opportunities and Challenges**

*J Ferreira, J Marques, MA Forjaz,  
MJ Almeida, C Almeida-Aguiar  
Universidade do Minho, Portugal  
nebaum@gmail.com,  
maf@math.uminho.pt,  
juditealmeida@bio.uminho.pt,  
cristina.aguiar@bio.uminho.pt*

**Abstract.** Science is the engine of society's development and the promotion of scientific literacy is very important not only to engage new generations in the world of science but also to make scientific concepts more clear, accessible and appealing to non-expert citizens. Science education should start as early as possible, awakening children to critical observation of the surrounded environment and the scientific thought. The most effective and successful way seems to be through experimental activities, which in turn should be provided as soon as possible.

To encourage a closer connection between science contents and children and youth, helping them blooming to science, the Experiment@Ciência project designed and implemented several scientific and interdisciplinary hands-on activities. "Experiment@Ciência", which involves three teachers from the Departments of Biology and Mathematics of the Sciences School of University of Minho, invited the "Núcleo de Estudantes de Biologia Aplicada da Universidade do Minho" (NEBAUM) to be their partners in several initiatives related with the communication of science to young people, challenging the students enrolled in the degree of Applied Biology (AB) at Universidade do Minho to be science communication agents in such activities. From this partnership several activities have been promoted for different publics. For instance, the "BA-LAB-DAY", a laboratory session to high school students and "Ciência p'ra que te quero", a set of experimental lab hands-on activities designed for children between 6 and 10 years old.

The development of teaching and learning strategies is a permanent challenge, especially if you are someone without any knowledge in



pedagogic issues and if you are still an undergraduate biology student. However, this fact did not make NEBAUM to give up this challenge, which was instead taken with enthusiasm and passion, with several NEBAUM students engaging actively with Experiment@Ciência in such outreach projects.

“BA-LAB DAY” had the purpose to provide high school students with the opportunity to experience the university’s atmosphere, as well as the kind of work performed at a molecular biology research laboratory, enabling students to try and perform a set of experimental techniques of the field.

The ‘Ciência p’ra que te quero’ initiative’s aim is to get children of a young age (6-10 years old) excited about science. This multidisciplinary initiative approaches matters of biology, mathematics, chemistry and even sociology and some others less represented sciences/subjects. The initiative is composed by nine sessions, running from February to December 2015, with each one having a different theme, but all with a similar structure. Firstly, a small introduction on the theme is made. Then children are divided in smaller groups of similar age in order to allow a more close interaction. At each station children are normally presented with a more interactive activity or an experiment where specific properties or details of the studied subject are explained and/or discussed. Once all the groups experienced all the activities, they were challenged with a small quiz about what they had learnt and a questionnaire related with the activities, trying to assess which they liked most and the reasons behind such preferences.

The present communication intends to present the activities in which Experiment@Ciência and NEBAUM worked as a team, testifying the challenges, the difficulties and the successes lived at NEBAUM during this collaboration.

**Keywords.:** Hands-on activities, multi disciplinary students’ projects, Science communication, Science teaching.

---

---

## Ionic Liquids Research and High School Students - In the Know and on the Go

*I Boal-Palheiros, AF Cláudio,  
M Freire, J Coutinho  
University of Aveiro, Portugal  
isabel.boal@ua.pt*

**Abstract.** In Portugal, and for some decades, enrolling in a degree in Biosciences and particularly in Medicine has been the target of the best secondary school students when they finish their high school studies. It is not frequent for the very best students to be interested in Sciences or Engineering in spite of the favorable employability rate of the latter, and efforts should be done to invert this tendency.

The University of Aveiro is a young (40 years) public university geographically located between two Portuguese old universities at Porto and Coimbra. The students that enrol in University of Aveiro originate near equally from Aveiro district (48 %), and from outside districts. In spite of being close to strong competitors, the university has been able to attract students from the rest of the country. The Department of Chemistry offers four degrees: Biochemistry, Biotechnology Chemistry, Chemical Engineering, and Chemistry. Except for the latter, the ratio candidates/vacancies is >1 and reaches 2.1 for Biotechnology, which is better than the national average. A most important strength of the Department of Chemistry is the high national and international quality and reputation of their research which can certainly captivate students. To highlight research in the field of Chemistry and motivate high school students to study science, they should be made aware and familiar with the activities in the research labs of our department. A good way to do that is to join the staff in their work and gather a close picture of how and why research is done. At the same time they may have the feedback of the staff on their degrees scope and potentialities.

The Portuguese national agency for scientific and technologic culture, Ciencia Viva [1], promotes initiatives and programs that aim at motivating students for science and technology. One of the most adequate programs for our purpose is OCJF [2], a program that is meant for students to actually

do science, mainly experimental science, within a research group for 1-2 weeks during their holidays.

In this study, we report the results of the two editions of this program that have occurred up to now. In both editions, the 11th and 12th grades students were integrated in one of the best research groups in the Department, PATH. This is a group of young, very dynamic and enthusiast researchers that produce world class research in the field of applied thermodynamics, and tops investigation in the recent field of ionic liquids. The theme is highly motivating due to the diversity of purposes and cutting edge technological and industrial applications it embodies, being, at the same time, amenable to be grasped by high school students. For one week, the students were given the opportunity to actually perform many of the real experiments, after a little training. Moreover, they could talk to the researchers about several aspects of both the research and their degrees in informal environment. The results of the program as well as the students' testimonies will be presented and analyzed.

**Keywords.** hands-on learning, high school students, ionic liquids, laboratory work, research practice, summer school.

## References

- [1] <http://www.cienciaviva.com/home/>
  - [2] <http://path.web.ua.pt/index.asp>
- 
- 

## Learning with Augmented Reality

*E Fernandes<sup>1</sup>, PC Lopes<sup>2</sup>, S Abreu<sup>3</sup>,  
S Martins<sup>1</sup>*

*<sup>1</sup>University of Madeira, Portugal*

*<sup>2</sup>Middle and Secondary School Ângelo Augusto da Silva, Portugal*

*<sup>3</sup>Middle School Prof. Dr. Eduardo Brazão de Castro, Portugal*

*elsa@uma.pt, crislopes@netmadeira.com,  
soniaabreu@live.madeira-edu.pt,  
smpcm@netmadeira.com*

**Abstract.** Augmented reality (AR) is an environment that includes both virtual reality and real-world elements. By using technological mobile devices such as smartphone, tablet or smart glasses, we can see the real world, as well as computer-generated images projected on top of that world.

A good analogy to better understand an AR environment is to imagine living in the magical world of Harry Potter, where the school hallways are lined with paintings that are alive and interactive. As in the movies, AR allows us to establish an interaction between virtual objects and the real world.

An augmented reality environment would include elements of the real world and the virtual world at the same time, and would be interactive in real time. The virtual objects could be either manipulated or stationary.

The use of AR is not a new concept. Azuma [1] points to at least six classes of potential AR applications that have been explored: medical visualization, maintenance and repair, annotation, robot path planning, entertainment, and military aircraft navigation and targeting. According to this author, one of the contributions of AR's use is that the virtual objects display information that the user cannot directly detect with his own senses and the information conveyed by the virtual objects helps the user to perform real-world tasks.

In the latter years, AR applications have become portable and available on laptops and mobile devices, and although much of the AR development is being done for marketing, amusement and social purposes, its use in education is emerging. The Horizon Reports, joint reports by The New Media Consortium

and Educause, predict that the use of simple augmented reality in education will be widespread within two to three years [2, 3].

In this exhibition we find many educational proposals to chemistry, physics, mathematics, biology and others. With free AR applications such as: Aurasma, Daqri, Mirage, Mathilde and Re+Public and by using mobile devices, users can interact with virtual elements related with different educational fields.

With “**Elements 4D**” application students can identify, spell, and list the properties of the thirty six elements from the Periodic Table using the Elements 4D blocks.

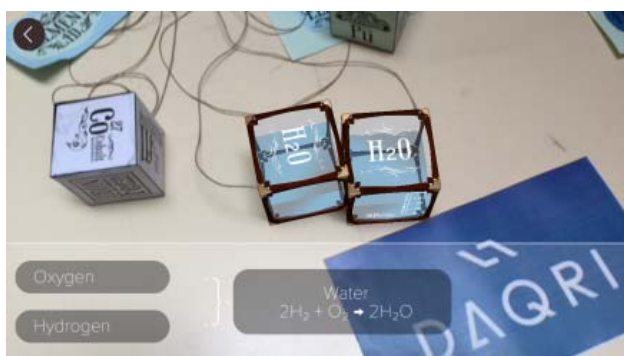

Figure1. Elements 4D

“**Anatomy 4D**” puts every detail of the most complex human body systems into a free app that is easy to use, accessible, and truly engaging. Learners explore bodily systems in depth through DAQRI’s 4D experience, which provides the opportunity to understand their interrelationships spatially – a learning experience previously only accessible in a gross anatomy lab.



Figure 2. Anatomy 4D

“**Mirage**” is a set of applications for mobile devices intended to be used in the classroom. These applications are related with different curriculum contents and are supported by lesson plans to be used by teachers. With the same paper markers, users can observe and interact with virtual objects (geometric solids, molecules, planets, satellites, etc.) from all

angles.

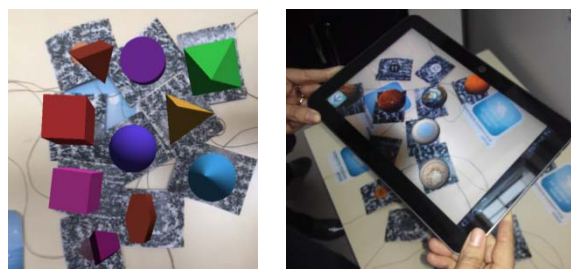

Figure 3. Mirage applications

This exhibition is carried on a BYOD (Bring Your Own Device) basis: users need to carry their personal mobile devices (smartphones or tablets) to upload the applications and interact with virtual objects.

**Keywords.** Augmented Reality, Learning, Technology.

### References

- [1] Azuma RT. A survey of Augmented Reality, Presence 1997; 6(4): 355-385.
- [2] Johnson L, Levine A, Smith R, Stone S. The 2010 Horizon Report. Austin, Texas: The New Media Consortium.; 2010.
- [3] Johnson L, Smith R, Willis H, Levine A, Haywood K. The 2011 Horizon Report. Austin, Texas: The New Media Consortium.; 2011

## Innovative Hands on Science Approach and Multi-pronged Communication Strategy to Dispel Myth about Nuclear Energy

A Srivastava

Nuclear Power Corporation of India Ltd.

amritesh@npcil.co.in,

amritesh.srivastava@gmail.com

**Abstract.** Nuclear power is globally accepted as a clean, low-carbon source of electricity in a safe, sustainable and cost-effective way. To communicate the undeniable merits of nuclear power to various sections of the society, we have been carrying out a gamut of public outreach activities over a period of time, conveying the facts on nuclear power in a simple and transparent manner. To widen the reach of these activities even further, NPCIL has scaled up its public outreach program manifold in a structured manner through a multi-pronged approach. The gist of these activities is to address the generally prevalent apprehensions about nuclear power and to allay the same that were aroused post-Fukushima. As part of this initiative, several innovative public awareness programs have been conceived and implemented for communities around the Indian nuclear power plant sites as well as at several other locations across the nation. There have been informative programs conducted at the grass-root level, involving local populations; scientific meets-cum-workshops for press and media personnel have been conceptualized and organized at different locations across the country; there have also been scientific meets for medical professionals; special educational tours to nuclear power plants for students and teachers have been organized; representatives of local communities as well as decision makers have visited nuclear power plants, and informative messages has been shared through popular public media like print, television, radio and film, to name just a few of the initiatives. Outlined is a summary of these initiatives that will go a long way towards fostering a greater understanding of nuclear power on the part of the public and its more realistic appraisal by decision makers as a definitive option for today and tomorrow.

## Overview

Multi-faceted public outreach program of NPCIL has been reengineered, adopting several refreshingly innovative means of communication in the spirit of openness and transparency. NPCIL has evolved an action plan with clear set of objectives, actions and timelines. A review and monitoring mechanism has been established and monthly reports are being issued to Department of Atomic Energy (DAE), Govt. of India. A dedicated team across NPCIL has been trained and deployed for partaking in the public outreach activities. In addition, NPCIL has partnered with many professional organizations for supplementing its outreach program and extending its reach even further.

## Methodology Adopted

In innovative mix of approaches has been adopted to maximize the impact of the public awareness campaigns. The use of TV commercials, advertisements, digital cinema, radio jingles, single-sheet print publications, comic books, etc. in vernacular languages, enhanced interaction with press and media, e-public awareness campaigns, rallies in support of nuclear power are a few, among many, modules that were adopted and gainfully utilized in various regions, across the country where nuclear power plants are located, particularly at green field / new launched sites.

## Birth of Comic and Cartoon Character “Budhiya”

In March 2011, a twin natural disaster comprising a massive earthquake and the accompanying tsunami of catastrophic scale hit the eastern shores of Japan, inundating Fukushima Daiichi nuclear power plant. All resulting fatalities there were due to the earthquake and tsunami and none due to radiation exposure. Yet, unfortunately, the general public and even the media largely misinterpreted the disaster. To allay the apprehensions and to dispel the prevailing misconceptions, an innovative set of sequel-based comic books and animated films were created in 7 languages by the author. For this, special sketched characters of “Budhiya,” representing a common man, and his other village friends, were developed. During the making of animation film, various characters were evolved based on the living of village

people to establish connectivity. Concept, story and screen play was developed by me and accordingly with the help of professional agency and required software, the animated film with 3 sequels were developed and screened at mass level at various platforms. Later on it was converted into many vernacular languages also. This approach was impacting, innovative as well as cost-effective because there was no need to hire human actors and also no costly shooting schedules were involved. The series has been widely appreciated for its engaging and interesting approach as well as wider mass appeal. Later on to popularize it on larger scale it was converted into the comics also which was basically a print screen of the animated film. Later on it was designed, laid out copy edited and published in many languages and widely distributed across all the corners of the country.

## Efficacy

As an outcome of these innovative hands on science approach, greater acceptability was noticed amongst the common people towards nuclear energy and all their myths and apprehensions were dispelled up gradually to the larger extent and they became ready to be a part of the success story. The objective to make them aware about the various aspects of nuclear energy was almost achieved efficiently and successfully.

STAR experiment at RHIC (Brookhaven National Laboratory).

The STAR experiment is one of the leading international collaboration in the field of modern nuclear physics. Many exiting discoveries, including new state of matter “Perfect liquid”, observation of antimatter helium-4 nucleus and strange antimatter, there were done.

STAR is composed of 56 institutions and universities from 11 countries, with a total of 557 collaborators. Students of these universities are actively involved in all stages of the experiment, and use the results of this work in the preparation of master's and PhD theses.

The goal of this project is to attract new students to this exciting research and the inclusion of the results of the STAR experiment in the educational process.

Using educational materials from our web resource, students and teachers could get much interesting information about various modern experiments, facilities and international collaborations.



## Educational Project for the STAR Experiment at RHIC

*V Belaga<sup>1</sup>, A Kechechyan<sup>1</sup>, K Klygina<sup>1</sup>,  
A Komarova<sup>2,3</sup>, Y Panebrattsev<sup>1,3</sup>,  
D Sadovsky<sup>2,3</sup>, N Sidorov<sup>1,3</sup>*

<sup>1</sup> JINR, Dubna, Moscow region, Russia

<sup>2</sup> InterGraphics LLC, Dubna, Moscow region, Russia

<sup>3</sup> National Nuclear Research University MEPHI, Moscow, Russia

**Abstract.** Modern education assumes significantly expand cooperation of universities with leading scientific centers for the training of highly qualified specialists. This report focuses on the MEHI and JINR joint project for the

There are following subsections: General information about STAR; Scientific Highlights; STAR detectors subsystems (General Info, Technical info, Operating principle, Photos); Instruments and methods for data analysis; Trigger system; Control Room; Virtual labs based on real experimental data; Online STAR data structure; Contact Information for Students. Most articles are visualized with interactive animations and 3D models that aimed at enhancing student's understanding of educational material and engagement in the process of science.

Currently a lab used experimental data on the gold-gold collisions at different energies



from 7.7 to 200 GeV to study production of antiprotons at RHIC collider is realised. As instrument for the complex study of events it is developed the module to visualize events using interactive 3-D graphics.

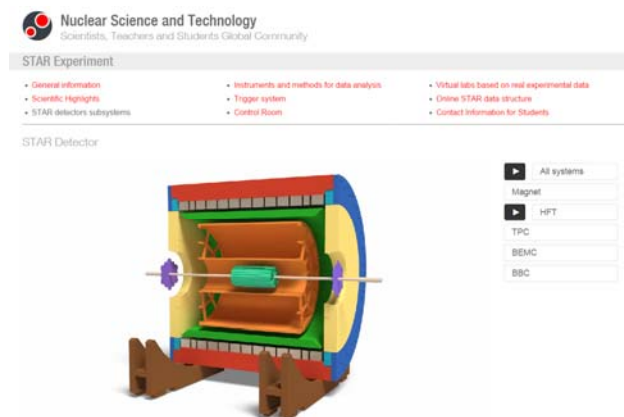

Furthermore it provides students from various universities of new educational resources appropriated to their level of education; allow to create community of students from different countries and universities interested in working on this area of science, will form a community of learners and teachers.

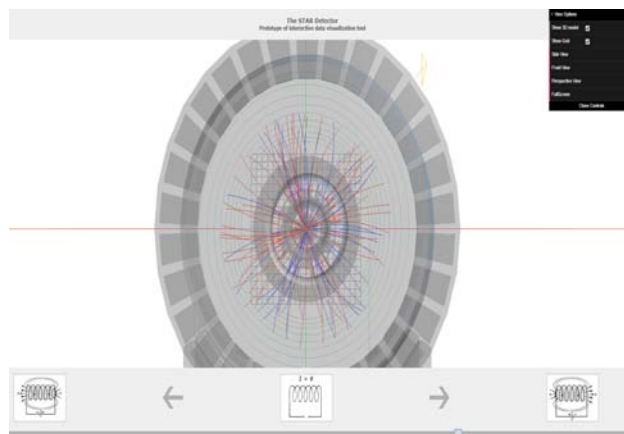

## Before versus After: “Word Clouds” as a Tool to Identify Adequate Key-Words Describing an Experimental Activity in a Chemistry Laboratory Context

TM Santos  
University of Aveiro, Portugal  
teresa@ua.pt

**Abstract.** To use knowledge or concepts arriving from different areas of a discipline and/or distinct ones, to link and to transform them in a useful, productive and creative way is, for various reasons, a task of difficult accomplishment. A very strong tendency to isolate and "compartmentalize" knowledge / concepts is known in all degrees of teaching, whenever students or even teachers are involved. A wider spread of concepts is desirable in a today's open world, which each time is more and more demanding in what concerns expertizing, flexibility and employment.

The "word clouds" are graphical tools often used in advertising techniques [1-4]. The words (keywords) used in their construction if properly selected can highlight, identify and/or separate relevant concepts [5]. It is also possible to superimpose concepts from different provenances or branches of a particular "science itself" or of "related sciences", allowing to link them so that these word clouds can simultaneously result in study promoters, in study materials and, above all, in a motivating and efficient tool to help learning.

In the here presented case of study, the aim is to improve "inter-communication" of basic practical knowledge and its underlying theoretical support by using "word clouds" constructed with the keywords extracted from the contents of the Laboratory Guide Book (Lab Q1), acquired by the study made at home, before doing the experiment, and the after performing it during the class and writing the respective report [6].

In this particular case both "bunch" of keywords have been transformed in a word cloud and compared. Another type of "data treatment" has been done comparing the world clouds obtained from two distinct groups of students: Biochemistry students, very focused in the



contents and with a much better previous preparation in chemistry from the Secondary School and “Sea Sciences” students, who show a much lower previous preparation in chemistry and more disperse science interests.



The size of the sample (ca 80 students) is suitable for a future statistical significant treatment, although it is felt that we need data refinement. So far, the receptivity, the collaboration and the interest shown by students in participating in the selection of keywords to make possible this type of experiment is quite encouraging. It is intended to enlarge the scope of this study selecting specific parameters in order to find relationships among them and plausible explanations for some type of results.

**Keywords.** Bridging theory and practice; brightening our future; learning with keywords; modern chemistry in today's world; motivation tool; word clouds.

### Acknowledgements

Thanks to CICECO – FCOMP - 01-0124-FEDER - 037271 (FCT – Pest - C/CTM / LA0011/2013) and Chemistry Department, University of Aveiro, Portugal.

### References

[1] <http://wordle.net/> “Wordle-Beautiful Word Clouds” [visited 20-Nov-2014 and April-May 2015].

- [2] <http://www.Edudemic.com/9-word-cloud-generators-that-arent-wordle/> [visited 20 - May-2015].
- [3] [http://21centuryedtech.wordpress.com/108 Ways to Use Word Clouds in the Classroom...Word Clouds in Education Series: Part 2](http://21centuryedtech.wordpress.com/108-Ways-to-Use-Word-Clouds-in-the-Classroom...Word-Clouds-in-Education-Series-Part-2) [visited Dec-2014-May-2015].
- [4] <http://worditout.com/>; <http://www.> [visited Dec-2014-May-2015].
- [5] Gorman Michael. 108 Ways to Use Word Clouds in the Classroom (<http://21centuryedtech.wordpress.com/>) (visited 25 – August - 2014).
- [6] Louçã F, Lopes JT, Costa J. Os Burgueses (quem são, como vivem, como mandam), Bertrand Editora, 1ª ed., Cap. 8-9; 2014.
- [7] Santos TM, Gonçalves IM, Nascimento E. Identificação de palavras-chave, Disciplina de Laboratório Q1, Departamento de Química, Universidade de Aveiro, Portugal, 2014/2015.

---

---

## The Views of Teachers on the Practice of Technology and Design Lesson Programme

*C Serdar, E Ceylan  
Technology and Design Educators  
Association, Adana, Turkey*

### Aim

Technology is defined as the process of transforming the datas of basic and applied sciences to production, using and analysing the social impacts of them in an innovative way. This approach highlights the reality that technology takes place in every kind of social activity as a process. Technology is a combination formed by science, art, engineering, economy and social work to increase the quality of life. It is an enterprise of doing any kind of thing better, faster, easier, more economical and more efficient.

Design is form imagined in mind. The usage

of cognitive process stands out in this definition. High-level cognitive processes such as finding the differences, dreaming, imaginative thinking, critical thinking, questioning and reasoning have great importance in making design.

Technology and design should be taken into consideration together as they are intended for product development and they directly affect the human life. Technology and design are the notions that directly affect each other. The relationship between them is like the one between subject and object. The primary cognitive process in this relationship is creativity.

Developing the relationship between technology and design can be possible through developing the creativity level of a person. Developing creativity requires not only being open to stimulants but also being aware of emotion, imagination, inner response and desires.

The era in which our children live will be different from the one we live in. For this reason, the ability, knowledge and manner that our children acquire will definitely be different. The studies reveal that the main feature of the era of our children will not be copying the products of others. It is impossible to meet the demands of the people living in tomorrow's world through tedious works without questioning, evaluation and observation that are essential for technology and design, and through the approaches only developing handcraft. For this reason, children should acquire the ability of guessing before the need arises, picking out different problems and finding creative solutions for them, designing and finding out the production process of the design. In light of the foregoing, the programme of Technology and Design Lesson is aimed to meet the demands of the era of future generations.

The content of the programme is seen essential by the experts when the aims and vision are taken into consideration. No matter how the programme is perfectly prepared, it depends on the qualification of the teacher and it will be invalid if it is not applied in educational context. The teachers as the main operators of the programme have important roles. The success of the Technology and Design Programme depends on to what extent it is

applied. Studies display that teachers have not applied the programme as it should be.

The attitudes towards the Technology and Design Programme are both the element that affects the programme to reach its goal and the result on the output of the lesson.

In order Technology and Design Programme to be applied successfully, teachers should develop positive manners and be willing. Starting from this, the studies should be done about teachers' manners towards the programme being applied since 2006-2007 academic year.

This study aims to display the effectiveness of the Technology and Design Lesson Programme, views of teachers on the practice and to suggest some solutions about the problems pertaining to the lesson.

## **Method**

This research is done through semi constructivist interview method which is predicated on qualitative research approach. Target population of the study is Technology and Design teachers working in the centrum of Adana in 2014-2015 academic year. From this population, samples are chosen through criterion sampling. According to this, 5 Technology and Design teachers working in the centrum of Adana have made up the samples of the study.

The comment results suggestions and findings pertaining to the study are not stated here since the study has not finished yet.



## Student Attitudes Toward Science and Technology in Public Education of Chile. Approach to Diagnosis of Situation

*X Vildósola-Tibaud, K Santander-Prat*  
*Universidad Metropolitana de Ciencias de la Educación, Macul, Chile*  
*ximena.vildosola@umce.cl, karolainasantanderprat@gmail.com*

**Abstract.** In different countries the lack of interest and negative attitudes of students towards science and technology are today the main problem of Scientific Education in the XXI century [1]. The number of students of science and technology in universities in the world has declined significantly over the last 15 years. The reasons are varied but it is likely this trend is related to unfavorable attitudes developed in school science.

A summary of extensive review of literature over the last 20 years about Latin America students attitudes towards learning science showed that students who choose to pursue a scientific career is 17 lower than Japan, 13 lower than United States and 8 less than Europe. While in Latin America has increased the interest of social sciences in 1990-2008, probably associated with social status of professions, natural and exact sciences showed an opposite trend with a lower ranking (2.7%) from other six areas options [2]. According this study the first reason of lack of interest in scientific careers be related to the difficulty of scientific subjects and boredom in school science. Students perceived a mismatch of content to their expectations with limited opportunities of learning and far into real life. [3; 4]. In this stage public education adds the uncertainty about the future have many students. In this context, a quarter of students public school don't know if continue to study but nevertheless this indicators contrasts with ten percent in case of private schools student. Nevertheless, most Latin American countries the public education is strongly affected by low socioeconomic status of students play attention that eight out of ten students showed a positive attitude towards science and technology, they trust in their beneficial role and make it easier and more comfortable everyday life. The contradictions of the role of science school and student interests and perspectives about

science and technology required more attention specially to recognized incidence of scientific-technological knowledge in development at society of twenty-first century.

### Objective

This study analyze student attitudes towards science and technology in primary and secondary public school.

### Methodology

A mixed methodology was developed, but this study presents results and discussion of quantitative data. We applied the questionnaire Science Class [5] This instrument consists of 18 statements into four analysis categories: I. "Ease of Learning"; II. "Appreciation of Science Subject"; III. "Educational Purpose" and IV. "Scientific-Technological Vocation. This study involved five public educational institutions of three zones of metropolitan region of Chile (Conchali, Quilicura, La Reina). The questionnaire was administered a total sample of 283 students: 162 of the last two levels of primary school (7th and 8th grade) and 121 student of 1st and 2<sup>nd</sup> level of secondary school, with a similar distribution by gender (male: 50.5% female: 49.1%).

### Results

The first results about to diverse criteria related of sociocultural context of students are exposed. Criteria such as educational level of parents showed that 39% of parents have completed secondary education, 32% have not completed their compulsory education (primary or secondary), 29% with technical studies and only 10% of parents have completed university studies. Regarding amount of science books or related at home trends are distributed equally between the options to 5 (32.9%), 5 to 10 (31.8%) and 10 (31.8 %). About use of computer resources, 50% use the internet yet observed a low frequency of use to pc or tablet (71.4%). Also, promotion of the family to know, enjoy or motivated by science and or technology through activities like trips to museums of science and / or technology, trade, educational farms was barely made visible in this study. Results showed the most higher frequencies distributed in most lower options, "rarely" and "never" used with a 77%. Finally, 22% of the student acknowledges support from their parents in relation to science as opposed

to 78% who recognizes not receive such support. Moreover, the assess of student attitudes toward science and Technology, results showed the most favorable trends in category IV, "Ground Scientific Technology". The students selected two highest response options (much agree and agree) with a 49,2 %. This category emphasized ideas like "I would be a scientist", "I would like to study so much science as possible" and "I would like to work in Technology". In contrast the other three categories students mostly selected options "no agreement" and "little agreement", category I "Ease of Learning" (57%), category II, "Appreciation for Science" (70%) and category III "Educational Purpose" (62%). All evidence support that primary and secondary school science it is poor in developing positive attitudes towards science and technology in students. Further we execute an ANOVA test about on three significant factors discussed above: "Educational Level of Students", "Parents Support" and "Gender" and broadly this analysis reinforces the tendency.

All the evidence indicate that socio-cultural context as well as the school has a weak impact on promoting interest in science and technology in the new generation of young Chileans. Clearly the family not played a central role but the school is not fulfilling a social role according with the challenger of nature of science and scientific inquiry. Chilean science teaching in primary and secondary school not appear to be a factor to improve the vision of science and technology or enhance the understanding of values role in personal and social life of students. Finally, public science teaching requires adaptation of the current curricula and to move towards the goals of current Scientific Literacy.

**Keywords.** Public education, science teaching, science and technology, student attitudes.

---

---

## **Active Learning in Optics and Photonics. Redesigning Circuits for the ALOP Workshop in Latin America**

*C Chacón<sup>1</sup>, F Monro<sup>1</sup>,  
C Ramírez<sup>1</sup>, AM Guzmán<sup>2</sup>*

<sup>1</sup>*Universidad Nacional de Colombia,  
Bogotá, Colombia*

<sup>2</sup>*CREOL, University of Central Florida,  
Orlando, USA*

*Angela.Guzman@creol.ucf.edu*

**Abstract.** The UNESCO initiative for Active Learning in Optics and Photonics (ALOP) has been globally recognized as an effective means of introducing high school teachers and first-year college instructors to a change of paradigm in science education. Active learning methodology goes beyond hands-on and inquiry-based learning methodologies by means of a "minds-on" approach that consists of a four-step methodology based on Prediction, Observation, Discussion, and Synthesis (PODS). This methodology has been pioneered by David Sokoloff and others at the University of Oregon. The ALOP challenges preconceptions of the students, and through a sequence of six modules builds up, using simple tools, the student's understanding of the foundations of optics and of optical communication, including wavelength division multiplexing. The initiative is spreading in Latin America under UNESCO's coordination and in collaboration with the Latin American and Caribbean Consortium of Engineering Institutions (LACCEI), which has obtained formal recognition by the International Gesellschaft für Ingenieurpädagogik (IGIP) of the ALOP Workshop as a valid course toward the IGIP's International Engineering Educator Certification. Full implementation of the workshop requires the construction of a set of circuits for optical communication using visible light, conceived originally by Alex Mazzolini from the Swinburne University of Technology in Australia. The circuits include an optical telegraph, an analog laser transmission circuit, and a three-channel wavelength division multiplexing circuit. The initial design used parts easily acquired in Asia but not in Latin America, necessitating a redesign. The National University of Colombia has been an enthusiastic supporter of ALOP, not only

holding several workshops at the University campuses around the country but by redesigning the circuits. We present here the schemes and prototypes of the newly redesigned circuits. With the auspices of the Abdus Salam International Centre for Theoretical Physics, the National University of Colombia is now developing all sets of circuits for 3-4 ALOP Workshops that will be held in 2015 in Latin America as part of the UNESCO celebration of the International Year of Light 2015.

**Keywords.** active learning, optical fiber communications, wavelength division multiplexing.

## References

1. *Active Learning in Optics and Photonics Training Manual*, ed. by David R. Sokoloff, UNESCO 2006.
2. *IGIP Recommendations for Studies in Engineering Pedagogy Science*, IGIP, Villach, Austria, 2005. [http://www.igip.org/pages/membership/files/curr\\_e.pdf](http://www.igip.org/pages/membership/files/curr_e.pdf)
3. IGIP's International Engineering Educator Certification ((ING-PAED IGIP, see <http://www.igip.org/pages/aboutigip/ing-paed.html>).
4. *A simple, low-cost demonstration of wavelength division multiplexing*, Alexander P. Mazzolini and Peter J. Cadusch, *Am. J. Phys.* 74, 5, May 2006.

style that incorporates technical, artistic and social components. This newly emerging trend is based on taking a scientific approach to cooking. Not only do chefs rely on chemistry, physics and biology to explore and understand the mechanisms of culinary transformations and processes, but they are also constantly developing novel methods and technologies that challenge and push the boundaries of traditional ideas about cooking.

In this scientific performance, we aim to provide all visitors with a modern, multi-sensory culinary experience by demonstrating Molecular Gastronomy techniques that showcase a range of local Madeira Island products (e.g., Madeira Wine, Poncha, passion fruit, etc.). Forming the basis of the Molecular Gastronomy techniques to be presented is sodium alginate. This polysaccharide, which is extracted from brown seaweed (or algae) in the form of alginic acid, is considered to be both food and skin safe by the U. S. Food and Drug Administration [1]. As such, it is found in a wide range of industries including food, pharmaceuticals, cosmetics and dentistry, etc.

In the food industry, sodium alginate is typically used as a natural texturing agent, an emulsifier, a gelling agent and a stabilizer in the preparation of food products such as ice cream, drinks and soups [2]. Moreover, it is considered a core ingredient in several Molecular Gastronomy techniques. One such technique is Spherification. This process, which is based on the ability of sodium alginate to form gels when used with calcium, is generally used to shape liquid into spheres [3]. Through demonstrations using this and other processes, all persons will have the opportunity to explore the science involved in the composition and transformation of certain food components to produce new and interesting dishes. Questions such as how and why certain ingredients work together will also be explored. It is hoped that through this unconventional modernist approach which involves the fusion of chemistry and cooking, a modern, multi-sensory culinary experience will be had by all.

**Keywords.** Molecular gastronomy, scientific approach to cooking, sodium alginate.

## References/Notes

- [1] Li Y, Rodrigues J, Tomás H. Injectable and biodegradable hydrogels: gelation,

---

---

## Molecular Gastronomy. Pushing the Boundaries of Cooking through Science

CS Alves, C Miguel, D Maciel,  
N Oliveira, H Tomás, J Rodrigues  
*Universidade da Madeira, Portugal*  
[calves@uma.pt](mailto:calves@uma.pt); [cmiguel@uma.pt](mailto:cmiguel@uma.pt);  
[dmaciel@uma.pt](mailto:dmaciel@uma.pt); [nilsa@uma.pt](mailto:nilsa@uma.pt);  
[lenat@uma.pt](mailto:lenat@uma.pt); [joaor@uma.pt](mailto:joaor@uma.pt)

**Abstract.** Molecular Gastronomy has emerged in the recent years as a new culinary

biodegradation and biomedical applications. *Chem. Soc. Rev.* 2012; 41: 2193–2221.

- [2] George M, Abraham TE. Polyionic hydrocolloids for the intestinal delivery of protein drugs: Alginate and chitosan - a review. *J. Controlled Release*; 2006; 114: 1–14.
- [3] Quantum Chef. Spherification Lessons. *MolecularRecipes.com*; 2011. <http://www.molecularrecipes.com/spherification/> [visited 09-Jun-2015]
- [4] The Fundação para a Ciência e a Tecnologia (FCT) is acknowledged for the financial support of our work (PEst-OE-UID/QUI/00674/2013).

effectiveness of this study was assessed via the application of a questionnaire (pre-test and post-test). The post-test were applied at the end of the semester (February). The research questions addressed in this study try to confirm the following hypotheses: a) The initial background of Medical Microbiology students in Medical Microbiology is acceptable; b) Students short-time retention is considerably higher than initial background. There are significant differences between the scores of the students in the experimental group and the students in the control group concerning the initial background and short-time retention. The results of this study indicated that the performance of the experimental groups was higher than the control groups due to strategies applied.

---

---

## Assessing the Impact of Medical Microbiology Classes Strategies on Short- Time Retention on Medical Students: an Innovative Study

MM Azevedo<sup>1,2</sup>, S Costa-de-Oliveira<sup>2</sup>,  
R Teixeira-Santos<sup>2</sup>, AP Silva<sup>2</sup>,  
IM Miranda<sup>2</sup>, C Pina-Vaz<sup>2,3</sup>,  
AG Rodrigues<sup>2,3</sup>

<sup>1</sup>School D. Maria II, Vila Nova de Famalicão, Portugal

<sup>2</sup>University of Porto, Portugal

<sup>3</sup>Hospital S. João, Porto, Portugal

**Abstract** This study was developed between October 2014 and February 2015 and involved two Universities: University of Minho, students of the 2<sup>nd</sup> year of Environmental Sciences (control group; n=30) and University of Porto, Faculty of Medicine, students of the 3<sup>rd</sup> year of Medicine (test group; n=127).

Promoting active learning is crucial to stimulate students. This study is based on the outcomes of an Educational study implemented with Portuguese Medical students of the Faculty of Medicine of Porto, Portugal, aiming to investigate the role of active learning strategies in short time retention. The

**Keywords** Medical Microbiology, Medical students, active learning strategies, short time retention.

---

---

## The Perception of the Population that Captures Mussels and Barnacles in Easter on Measures of Ecosystem Conservation

M Jeremias<sup>1</sup>, S Seixas<sup>1,2</sup>

<sup>1</sup>Universidade Aberta, Lisboa, Portugal

<sup>2</sup>Universidade de Coimbra, Portugal  
sonia.seixas@uab.pt

**Abstract.** The perception of the population that captures mussels (*Mytilus galloprovincialis*) and barnacles (*Pollicipes pollicipes*) on Holy Friday on the campaign launched by the Cascais city council (“In Easter the one who pays is the mussel”) to prevent the depletion of the stocks and their opinion on the need of preservation of these two species and biodiversity in intertidal area.

To evaluate it we went to the area where the campaign was launched and made a questionnaire to each family, in a total of 62 surveys.

This activity is mainly carried out by men between the ages of 30 and 60 years old. 62% of the collectors came from different areas of



the council, 30% came from neighbouring councils and the other 8 % from distant places.

The results confirm that the capture is mainly done in Easter (82%).

41% of the people inquired collect mussels, 16% collect barnacles and 43% collect both species.

The majority of the collectors knows the maximum weight allowed to capture mussels but doesn't know it about barnacles and less than half of the people answered correctly about the minimum length of the mussel shell.

94% stated that the capture is to private consumption.

The perception of the people about the conservation of both species and biodiversity in intertidal is above 70%.

As far as the campaign is concerned, people, in general, agree with it but their answers are not consensual in information given by local authorities in field: some said it is very good (40%) while others said that it is very bad (47%). About the reinforced surveillance done during this day by the Maritime and the City Council Police almost everybody said that it may end up with this tradition.

**Keywords.** *Mytilus galloprovincialis*, *Pollicipes pollicipes*, mussel, barnacle, Holy Friday capture, conservation, biodiversity.

---

---

## Control of Carnivore Overpopulation (Egyption Mongoose and Red Fox) – Study Case in the Council of Azambuja (Portugal)

*M Teodósio, S Seixas*  
*Universidade Aberta, Lisboa, Portugal*  
*marisaact@gmail.com,*  
*sonia.seixas@uab.pt*

**Abstract.** The presence of predators in a habitat is considered a stabilizing force in the population of herbivores, contributing to the balance of the ecosystem. However, the predator's overpopulation causes a drastic reduction of primary consumers, exceeding the capacity of the ecosystem and endangering the entire food chain. To solve that situation, density control actions are being implemented by man, for balance maintenance purposes or to prevent damages. Often, in the council of Azambuja, there are carried out these actions, by Hunting Associations to control the carnivore population in forest areas, in particular the egyption mongoose (*Herpestes ichneumon*) and the red fox (*Vulpes vulpes*), for their allegedly effect on the lagomorphs population decline. The objective of this study was to describe the capture process end-to-end: how the authorization is required, how is it done in the field, how the fiscalization is made and the results on the biodiversity.

The methodology used was the record of the process, interview of the people responsible in field for this actions, and consultation with the national authorities involved.

It was verified that the national services which controls these actions (National Institute for Nature Conservation and Forestry) and responsible for the evaluation of the licenses requests, issued these ones to a local hunting association, without any previous study of those two species population's densities or maximum carrying capacity of the environment for them. There's no effective supervision of the implementation of this action in the field. It was also clear that hunters use these actions, not to guarantee the ecosystem balance, but to eliminate predators in order to rise the lagomorph's population for the hunting season. So a process that first established the ecosystem's balance, can and may do exactly

the opposite.

**Keywords.** *Vulpes vulpes, Herpestes ichneumon, overpopulation control, ecosystem balance.*

---

---

## Developing Environmental Awareness of High School Students: 3rd Enka Ecological Literacy Camp as an Example

*ER Şükrüye*  
*Adapazarı Enka Private High School,*  
*Sakarya, Turkey*  
*ser@enka.k12.tr*

**Abstract.** Natural sources have been used by people because of growing demands. Unfortunately, irreversible mistakes have been made and natural balance has been broken. This is why, nature education is so crucial in developing environmental knowledge and environmental awareness for responsible environmental behaviours. As far as most of the researches are concerned, when the age decreases, students' environmental attitude increases [1, 2]. So early age students' knowledge, attitudes and responsible behaviours can be increased by outdoor activities (greenhouse activities, field trips etc.) [3].

In the project we carried out at Enka School in 2014-2015 academic year, it is aimed at educating young people in order to increase their understanding of ecological sensitivity and develop their positive behaviours towards nature. Since environmental education is an interdisciplinary study, biology and geography teachers at Enka School worked together within the frame of this project. Nineteen high school students from grade 9 to 11 participated to the project between 24-26 April 2015. University collaboration was carried out successfully during the camp activities.

**Keywords.** Ecological literacy, environmental education, nature education.

### References

[1] Erdoğan M. The Effects of Ecology-Based Summer Nature Education Program on

Primary School Students' Environmental Knowledge, Environmental Affect and Responsible Environmental Behavior. *Educational Sciences: Theory & Practice* - 11(4); 2011.

[2] Erentay N, Erdoğan M. 22 adımda doğa eğitimi. Odtü Yayıncılık: Ankara; 2009.

[3] Palmeg IE, Kuru J. Outdoor activities as a basis for environmental responsibility. *Journal of Environmental Education*, 31 (4), 32-37; 2000.

---

---

## inGenious Project in my School

*E Vladescu*  
*National Vocational College "Nicolae Titulescu, Romania*  
*elenavladescu@yahoo.com*

**Abstract.** During 2013-2014, I worked in the inGenious project, as a pilot school teacher. inGenious

is the European Coordinating Body in Science, Technology, Engineering and Maths (STEM) education, one of the largest projects in science education undertaken in Europe, coordinated by European Schoolnet. This project had the main objective of increasing the links between science education and careers, throughout Europe. My students are from 15 to 18 years old. In this paper I will present the activities I implemented with my pupils in the frame of inGenious.

## Evaluation and Comparison of Robotic, Mechanic and Programming Skills among 9 to 14 Years Old Children with and without Lego Education

H Güvez<sup>1</sup>, O Yılmaz<sup>2</sup>

<sup>1</sup>Tuba KAMIŞ (Psychologist)

<sup>1</sup>Mahallesi 620-1 Sokak Mavi Bloklar F Blok  
Kat:6 Daire:23 Gebze  
hakanguvez@mynet.com,  
tuba.kamis@hotmail.com

**Abstract.** The subject of this paper is the research base on comparison of robotic, mechanic and programming skills between the children who were taken Lego education and were not taken Lego education in their early life, for the age groups differs from 9 to 14 years old.

Experimental works with children were done at Maltepe Menar Education Centre between the age groups from 9 to 14 years old. Firstly, they were taught Lego Mindstorm NXT which is the basic education tool to help children problem solving, collaboration, and critical thinking skills. Secondly, they were expected to analyze complex situations and to express better handicraft as well as better presentation ability. Then, results were collected to show the importance of Lego education.

In this study, the approach applies the pedagogical methods that have been learned from the success of children and adult education, using electronic blocks or construction sets [1,2].

The total numbers of experimental works were 115 in order to obtain clear results. While evaluating results, survey of five likert scale was used. This developed model which was used to provide correct results, showed the importance of Lego education. The children who were taken Lego training indicated a lot better performance in many areas (like robotic, mechanical and programming skills) than others.

**Keywords.** Robotic, Mechanic, Programming skills, Lego training, robotic education

## References

- [1] Weinberg J, Engel G, Gu K, Karacal C, Smith S, White W, Yu X. "A Multidisciplinary Model for Using Robotics in Engineering Education," Proc. Am. Soc. Eng. Education Ann. Conf.; 2001.
- [2] Wyeth P, Purchase H. "Using Developmental Theories to Inform the Design of Technology for Children," Proc. Conf. Interaction Design and Children, pp. 93-100; 2003.

---

---

## Lessons Learned from the INSTEM Project

*A Sporea, D Sporea*

*National Institute for Laser, Plasma and Radiation Physics, Romania*

*Center for Science Education and Training, Romania*

*adelina.sporea@inflpr.ro,  
dan.sporea@inflpr.ro*

**Abstract.** The Center for Science Education and Training – CSET (<http://education.inflpr.ro/>) at the National Institute for Laser, Plasma and Radiation Physics in Bucharest is member of the European Comenius network INSTEM (<http://instem.tibs.at/>) formed by 14 institutions aiming to promote inquiry based teaching, to gather innovative teaching methods and to raise students' interest in science as well as offering them careers information in STEM subjects, in order to respond to global challenges in teaching and gender imbalances in STEM education. The present paper presents the activities and the results obtained by the CSET team participating to the INSTEM project.

As per the project planned activities, we run several national workshops aiming to promote the project, to advertise its objectives and tasks and to analyse at national level the impact of European projects on inquiry-based science teaching and the way these projects results are disseminated. This analyse will assist the international team to design better dissemination policies at European level.

A second major task of our team was to provide a case study related to our participation

to a major European project on IBSE. Within this assignment, we studied the impact the Fibonacci project had on our activities at national level.

The Romanian team contributed also to the evaluation of state-of-the-art at continental level as it concerns STEM education.

As beneficiary of the project financial support, we were able to invite several Romanian teachers and educational policy makers to participate to the two international conferences the project organized in Halle and Freiburg. This was a good opportunity for them to meet fellow educators, to express their views on STEM education and to start new collaborations.

**Keywords.** inquiry-based science teaching, STEM education.



## **Brightening the Classroom: Hands-on Organic LEDs and Solar Cells**

*J Dörschelln, A Banerji*  
*University of Cologne, Germany*  
*j.doerschelln@uni-koeln.de, a.banerji@uni-koeln.de*

**Abstract.** Electronics, whose functional elements are based on semiconducting organic materials (small molecules or specific polymers), are related to organic electronics. This is no longer a vision, it's an inherent part of our everyday life. This kind of electronics are already being used in smartphones and curved-TVs. Moreover, in future it is going to play a major role in our living environment.

Together with our partner in Wuppertal (Prof. M. W. Tausch), we have developed didactical concepts and experiments for OLEDs (organic light emitting diodes) and OPVs (organic photovoltaic cells) [1-5]. The materials have been tested in formal as well as informal learning settings together with more than 60 teachers and students.

In this year's conference, we will present a didactical suitcase including all necessary

materials for building OLED and OPV devices. The construction of a luminous OLED device will be demonstrated in a live experiment. Furthermore, we will introduce an interactive learning-tool for understanding the elementary processes in an OLED device.

**Keywords.** OLED, OPV, Organic Electronics

## **References**

- [1] Banerji A, Tausch MW. Elektrolumineszenz in organischen Leuchtdioden, Praxis der Naturwissenschaften - Chemie in der Schule; 2010, 59 (4): 42.
- [2] Banerji A, Tausch MW. Funktionelle Farbstoffe, PdN-ChiS; 2010, 59 (8): 6.
- [3] Banerji A, Tausch MW, Scherf U. Fantastic Plastic - von der Cola-Flasche zur organischen Leuchtdiode, CHEMKON; 2012, 19(1): 7-12.
- [4] Banerji A, Tausch MW, Scherf U. Classroom Experiments and Teaching Materials on OLEDs with Semiconducting Polymers, Educacion Quimica; 2013, 23 (4): 1-6.
- [5] Tausch MW, Zepp M. Organische Photovoltaic, Praxis der Naturwissenschaften - Chemie in der Schule; 2015, 64 (1): 18.



## **Hands-on Fieldwork**

*R Freitas<sup>1</sup>, A Baioa<sup>1,2</sup>, R Borges<sup>1</sup>*  
*<sup>1</sup>Centro Ciência Viva de Tavira, Portugal*  
*<sup>2</sup>Agrupamento de Escolas D. Manuel I de Tavira, Portugal*  
*rfreitas@cvtavira.pt*

**Abstract.** Although 70% of our planet is Ocean, there is a general lack of information about ocean processes and on the value of the ocean to society. Increasing ocean literacy must be a priority so that informed and responsible decisions about the ocean can be made. Despite its importance, in schools Ocean topics are not yet commonly explored, and there is a debate on whether these should be included in formal curricula. Non-formal approaches can play a major role to fill this

gap. Hands on activities, in particular, can be very effective in this regard. If these include field work focused on exploring marine science topics, this approach can be very effective to promote ocean literate citizens. Science centres, in particular those located in coastal zones, can play a major role to promote non-formal learning about the ocean through field work that allows a better understanding of patterns and processes in the ocean, as well as the use of scientific methodologies commonly used in marine sciences. In 2012-2015, the project “Ciência em Tavira” promoted set of activities, including a Science Club, at a local school. The Science Club was streamlined by the Tavira Ciência Viva Science Centre. Many of the topics explored in some of the sessions, were related to the Ocean. In one of the science club activities, students were able to work closely with a marine biology researcher in order to increase knowledge about zooplankton biodiversity and sampling methods. Field work at the Ria Formosa coastal lagoon, a fundamental ecosystem included in a natural park, allowed the students to collect zooplankton samples through plankton nets commonly used in marine biology, deployed with the help of the researcher and the science centre explainers. The samples collected in the lagoon area and taken to the school laboratory afterwards for further analysis. In the laboratory, the researcher explained the importance of zooplankton in marine ecosystems and food webs, and the students could observe the plankton biodiversity and identify the zooplankton main groups collected during the fieldtrip.

**Keywords.** Marine biology, Fieldwork, Labwork, Hands-on activities.

---

---

## Hands-on Science in the Kindergarten

*S Santos, J Pescada, R Freitas,  
A Moura, D Ferreira, V Cavaquinho,  
R Borges*

*Centro Ciência Viva de Tavira, Portugal  
ssantos@cvtavira.pt, rborges@cvtavira.pt*

**Abstract.** Aiming at introducing kindergarteners to science, the Tavira Science Centre has been implementing hands-on activities for young children at kindergartens on a regular basis, since 2011. Activities are implemented through inquiry based learning approaches, allowing the exploration of multiple scientific concepts. This is achieved with experimental activities that promote learning through the use of simple materials related to the children’s daily life. Complex concepts such as heat, gravity, viscosity, among others, are explored through scientific methods, allowing the development of cognitive and fine motor skills.

After four years of implementation, it is clear that children that participate in these activities reveal stronger learning capabilities and abilities to connect concepts compared to other children with the same age that don’t experience regular science hands-on activities.

**Keywords.** Hands-on science, kindergarten activities, science experiments.

---

---

## Mathematics Higher Education with Interactive Computing Resources

JNM Ferreira<sup>1</sup>, L Camacho<sup>2</sup>, M Garapa<sup>3</sup>

<sup>1</sup>Universidade da Madeira, Portugal

<sup>2</sup>Escola B+S Padre Manuel Álvares,  
Madeira, Portugal

<sup>3</sup>Escola B+S Dr. Ângelo Augusto da Silva,  
Madeira, Portugal

luiscmch9@gmail.com, nelio@uma.pt,  
marcogarapa@gmail.com

**Abstract.** The potential of the use of technology in education is clear and requires a rethinking of the teaching methods. New pedagogic practices can also be introduced in higher education in order to enhance the learning through the use of technology.

We have developed some computational and interactive resources, suitable for mathematics teaching in Higher Education. These resources allow the learning process to be more dynamic, involving the manipulation of objects and simulations, which in turn contributes to the understanding of abstract concepts.

In this communication we show an example of one of these resources that can be used in a context of a Calculus course. This example is properly placed in the context of a problem and it is intended to approach a mathematical concept exploring the potential of the computer resource in terms of three-dimensional representation and its characteristics such as the interaction and manipulation.

It is intended to integrate these resources into an interactive lecture notes for a Calculus course taught at the University of Madeira. We believe that this will be a useful tool to support the teaching of the course providing the creation of an educational environment where students can take an active role in their learning, through the visualization and interaction with different objects improving the understanding of concepts.

**Keywords.** Computational Interactive Resources, Higher Education, Mathematics.

## Science Outreach Activities at CQM-Centro de Química da Madeira

H Tomás

Universidade da Madeira, Portugal

lenat@uma.pt

**Abstract.** The CQM-Centro de Química da Madeira (Madeira Chemistry Research Centre) is a Portuguese research unit supported by the Portuguese Foundation for Science and Technology (FCT). Beyond research activities in the fields of Natural Products and Materials (CQM main mission), the unit has always given special attention to the spreading of science to the young in particular and to the public in general. Indeed, CQM aims to interact directly with society, inspiring new talents in Chemistry and Biochemistry and showing the importance of science for the development and well-being of society. Activities including scientific dissemination events, as well as presentations demonstrating CQMs own contribution to science, all play a role in this.

This presentation will cover a range of outreach actions that CQM has promoted since its conception, namely: “A QUÍMICA É DIVERTIDA” (Chemistry is Fun) which is now 20 years old and consists of a balanced mix of science popularization activities (colloquia, experimental demonstrations, competitions, etc.), usually being done during the National Week of Science and Technology; “NOITE DA QUÍMICA” (Night of Chemistry) that took science to the centre of Funchal to commemorate the International Year of Chemistry (IYC 2011); research training periods for high school students during the summer holidays; TV programmes for young children (PANDA cable TV channel) that were recorded in 2007; and a newsletter edited in English and in Mandarin that highlights research and training activities in CQM. More recently, a new science outreach project was launched by the CQM. “Bridging the Gap – Chemistry and Biochemistry in the Real World” consists of a well-defined package of activities (mostly hands-on experiments) to be done in different contexts (schools, elderly homes, and hotels).

Indeed, we believe that Chemistry is an important science and that people with a higher level of scientific literacy are better prepared to



face the new challenges that the future will bring.

**Keywords.** Centro de Química da Madeira, Chemistry and Society, general public, outreach activities.

### References/Notes

[1] The Fundação para a Ciência e a Tecnologia (FCT) is acknowledged for the financial support of our work (*PEst-OE-UID/QUI/00674/2013*), as well as Agência Nacional para a Cultura Científica e Tecnológica Ciência Viva for supporting part of our outreach activities.

---

---

## Ars Lux laser Harp – the Musicality of Light

*A Lello*<sup>1</sup>, *A Almeida*<sup>2</sup>, *C Souto*<sup>3</sup>, *R Rocha*<sup>4</sup>  
<sup>1-3</sup> 12th grade Students, <sup>4</sup>Teacher  
Colégio Luso-Francês, Porto, Portugal  
*andre.lello@hotmail.com,*  
*antonio\_closeau@hotmail.com,*  
*catarinasouto@hotmail.com*  
*rita.rocha@lusofrances.com.pt*

**Abstract.** A laser harp is a musical instrument whose functioning is built on the blocking of laser beams with the purpose of producing sound. Depending on the beam that is blocked, a different sound, i.e., a distinct musical note, is produced. Ars Lux employs eight low-power lasers and a single-board computer, thus making it easier to build and economically viable. Unlike the more common laser harps, when an Ars Lux laser beam is cut at different heights, there is a variation in the volume of the note that is emitted. This ability leads to a truly unique prototype, merging Art and Light Sciences. In this communication, we will present a one year work process focused on Project-based methodologies. This pedagogical methodology allowed the development of several key competences such as time management, argumentative thinking, procedural research skills and collaborative work.

As the winner of the first prize in the Science Fair IYL2015/Portugal "À Descoberta da Luz"

national contest that took place in May25 in Viana do Castelo, Portugal, we hope to present all HSCI2015 participants with a laser harp concert.

**Keywords.** Laser harp, Project-based Learning, formal education, collaborative work, tutoring teaching.

---

---

## Where Science Meets Oral Narrative

*M Condesso*<sup>1</sup>, *P Pombo*<sup>1,2</sup>

<sup>1</sup>*Fábrica Science Centre of Aveiro, Portugal*

<sup>2</sup>*University of Aveiro, Portugal*

*martacondesso@ua.pt, ppombo@ua.pt*

**Abstract.** At several places (city gardens, school libraries, science centres) reading performances can become peculiar science communication acts.

Curiosity and interest on technological, scientific knowledge and on literature can come together, in an intimate ambience of storytelling.

Expressive moments of "once upon a time" or "just listen to what I'll read!" are powerful means to conduct audience's attention to a certain scientific concept, principle, phenomenon that a certain text hides inside and can motivate to an inquisitive relevant attitude respecting everything around us.

Using only words and gestures, narrator can get listeners' attention to classical or modern literature, oral tradition, published authors or unknown ones as well as to basic or frontline science subjects, at the same time.

Narration performances mix fantasy and rigor in order to get generous smiles and engagement, from public of all ages, towards Word and Science.

International Year of Light becomes a good excuse to a scientific look on every bit of literature we read or listen to, and on anything after that.

While appealing narratives are being shared, simple notions on Light can be

disclosed (propagation, wavelength, reflection) and basic experiments can be tested (periscope's functioning for instance), hopefully leaving in each person the most powerful certainty: "I easily got the idea! I can do that!".

---

---

## Design and Implementation of a Remotely Controlled Physics Lab (RCL) Based on a Raspberry Pi: the Case of a Simple Optics Experiment

G Mitsou<sup>1</sup>, V Dionisis<sup>2</sup>,  
J Karachalios, I Sianoudis<sup>3</sup>

<sup>1</sup>Department of Energy Technology  
Engineering, TEI of Athens

<sup>2</sup>University of Thessaly, Volos, Greece

<sup>3</sup>Technological Educational Institute (T.E.I.)  
of Athens, Egaleo/Athens, Greece  
gmitsou@teiath.gr, dvavou@uth.gr,  
jansian@teiath.gr

**Abstract.** The development of information and communication technologies (ICT) in the present times facilitate the adoption of new ideas and applications in education systems and methods, such as are techniques in the remotely controlled educational experiments. This approach allows the implementation of physics experiments over the internet without the need for expensive equipment or software. In this study, we have developed a method for operating a remote, University level Physics Laboratory, using the internet and interface techniques that allow students to fully control the whole experimentation process. An appropriate environment based on the technology of the Raspberry Pi microcomputer systems is used as a lab server, because of their low cost, ease of use, as well as general accessibility they provide. As an example we describe a physics experiment in Optics, as a sample application already available.

---

---

## A Workshop on How to Create Sciotoons and Making Science Learning a Joyful Experience

P. Kumar-Srivastava

Medicinal & Process Chemistry Division,  
Central Drug Research Institute, Lucknow,  
INDIA

pkscdri@gmail.com

**Abstract.** Science education and research is facing now-a-days a tough challenge around the world. Many times, the way it is being taught, it looks very technical, less interesting and sometimes even boring. Educationists around the world including in USA are worried as students are opting for more lucrative career options in business, commerce and information technology. This trend is not a healthy one as no country can progress without the development in science. Now-a-days most of the scientific researches have become interdisciplinary and many experts from different background have to work together. To communicate to such different experts from various disciplines, is a real challenge.

It is well said that a picture is worth thousand words. Cartoons are the combination of caricature and satire. Caricature means distorted drawing and satire means a humorous comment. If the subject of the cartoon is science then they are called science cartoons. Sciotoons are a new class of science cartoons, based on science. They not only make you smile and laugh but also provide information about new researches, subjects and concepts in a simple, understandable and interesting way. Sciotoonics is new branch of science, which deals with effective science communication using a novel class of science cartoons called sciotoons. Sciotoons have been recognized/ appreciated all over the world by several international organizations including WHO, UNESCO, UNEP, Royal Swedish Academy, International Union of Pure and Applied Chemistry, American Chemical Society, Junior Chamber International (USA), DECHEMA, Germany and also by NCSTC (DST, Govt. of India), CSIR, Indian Science Congress Association and many more. European Science Festival 2008 held from July 18-22, 2008 at Barcelona, Spain, organized a full session on Sciotoonics (www.esof2008.org)

This Scientoon based audiovisual technique is more useful when a scientific program is undertaken to make people understand and learn and thus create interest in that area for higher education/mass awareness. In this workshop a live demonstration of the entire process **as how to create scientoons**, which will that how complex subjects of science can be presented and effectively explained using scientoons so that the science communication/education/research in these areas can be made more informative, effective, interesting and useful.

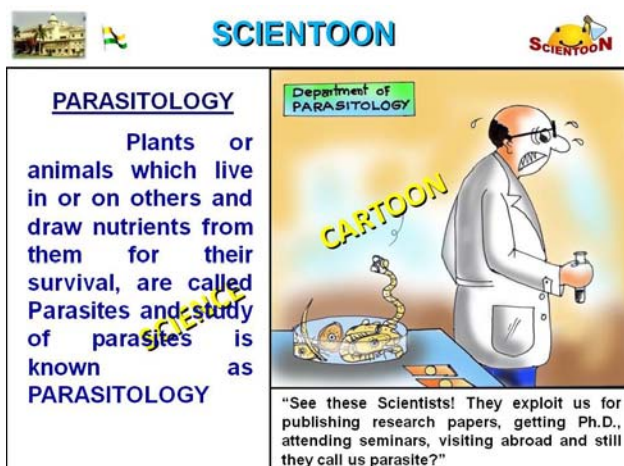

---

---

## Body Language to Understand Relativity

X Prado  
IES Pedra da Auga, Ponteareas,  
Pontevedra, Spain  
xabier.prado@yahoo.com

**Abstract.** This workshop will focus on the possibilities of corporal language (hand signs, arms and body movements, songs) to be used as a teaching tool and a learning help to show and develop relativity in the classroom at early pre-university levels, as well as at informal learning activities like science fairs, public demonstrations and scientific divulgation in general. The approach is based on the geometric formulation of relativity in spacetime by Minkowsky, and it has been developed by the author in several ways, including presentations in science teaching forums like Physics on Stage [1], ESERA [2] or Hands-On Physics [3]. The ideal duration of the workshop

would be of 1 hour to allow detailed presentation and interaction with the participants, but it can be shortened until a minimum of 30 minutes. In this time, the participants will be encouraged to feel by themselves the spacetime diagrams and their physical interpretation using their bodies in a choreographic manner to produce the new physical meaning in the following sequence:

Spacetime as explained by Minkowski; Aristotle's ideas about space, time, movement and the instant; Galileo and classical relativity; Experimental evidence by Michelson and the GPS operation; Lorentz transformation; speed limit as proposed by Einstein; the role of the speed limit in the CERN and at the borders of the Universe.

The main ideas will be fixed singing a song where hand movements help the explanatory text to be fixed in our minds more easily.

This sequence has been used to convene an international online conference of secondary students from UNESCO-Associated Schools in 7 countries (Spain, Germany, Greece, Italy, USA, The Netherlands and Switzerland) to commemorate the International Year of Light 2015 under the title of "New Light with Old Ideas" [4].

**Keywords.** Relativity, spacetime, speed limit, body language.

## References

- [1] Prado X. Visual Relativity (Interdisciplinary Didactic Unit); 2000.  
[https://sites.google.com/site/handsonrelativity/home/physics\\_on\\_stage\\_cern2000](https://sites.google.com/site/handsonrelativity/home/physics_on_stage_cern2000)  
[visited 16-May-2015]
- [2] Prado X, Dominguez JM. A didactic proposal for the visual teaching of the theory of relativity in high school first course. In Tasar MF, Çakmakci G, editors. Contemporary Science Education Research: Teaching 2010 (proceedings of ESERA 2009 Conference) p. 297-305.
- [3] Prado X, Domínguez JM. Audiovisual Animations for Teaching the Theory of Special Relativity Based on the Geometric Formulation of Minkowski. In: Hands-on Science. Science Education with and for Society. Costa MFM, Pombo P, Dorrió BV

(Eds.), Hands-on Science Network, 2014,  
Pages 259-266.

- [4] New Light with Old Ideas. International online conference of secondary schools about relativity.

<https://sites.google.com/site/newlightoldideas/home/ideas> [visited 16-May-2015]

---

---

## Teaching the Elusive Concept of a Photon

*AM Guzmán*  
*CREOL, University of Central Florida,*  
*Orlando, USA*  
*Angela.Guzman@creol.ucf.edu*

**Abstract.** One of the intended goals of the International Year of Light 2015 is to achieve that people get familiar with the word photonics and the crucial role that photonics technologies play in our life. While young people is fascinated by the word photon, the concept of photon as depicted in standard high school textbooks is often misleading, and lead students usually to think of photons as point particles with a permanent undeletable identity of their own even when transpassing material boundaries. But two giants have warned us of the misuse of the term photon, and much more of our confidence on our own understanding of the concept. The well-known Einstein's sentence: "All the fifty years of conscious brooding have brought me no closer to the answer to the question: What are light quanta? Of course today every rascal thinks he knows the answer, but he is deluding himself", is indicative of the complexity of the concept of photon. Willis Lamb Jr, Nobel Prize in Physics 1955, suggested at the first of the 1960's Rochester Coherence Conferences, that a license be required for use of the word photon, and offered to give such license to properly qualified people. It is time to present the concept to young people more rigorously, through examples from optics and classical electromagnetism. Photons are usually given a particle-like reality linked to quantization in free space. But photons in a medium are different from those in free space, those that travel in vacuum and without boundaries. When light is

transmitted from a transparent material to another, or is kept confined in electromagnetic cavities or photonic crystals, photons have to obey Maxwell's theory of electromagnetism and accommodate themselves into the available electromagnetic modes that satisfy the boundary conditions of the classical electromagnetic problem. Quantization of the electromagnetic field for a simple reflection-refraction process at the interface between two transparent media, the total internal reflection and evanescent waves, electromagnetic waves with orbital angular momentum, single atom masers, and other simple cases is more appropriately done in terms of the electromagnetic modes characteristic of the physical boundaries of the system, and a single photon in one of these modes might result in a linear quantum superposition of many free-space photons. I present several examples that illustrate this point and strip the concept of the photon of any point-like behavior and the photon itself from an identity per se.

## References

- [1] Anti-photon, W. E. *Lamb*, *Appl. Phys. B* 60, 77-84; 1995.
- [2] *The Nature of Light: What is a Photon?* Edited by Chandra Roychoudhuri, A.F. Kracklauer, Kathy Creath, CRC Press, Taylor and Francis; 2008.
- [3] *OPN Trends—The Nature of Light: What Is a Photon?* Chandrasekhar Roychoudhuri and Rajarshi Roy, *Optics&Photonics News*; October 2003, OSA.

---

---

## Green Box Technique: New Way of Learning Method Improves Student's Comprehension Skills

*E Sobaci*  
*(4<sup>th</sup> Grade METU Student)*  
*emresbc@gmail.com*

**Abstract.** The purpose of this study is to show the importance of green box technology and animation technology which include association of things with memorable images or with a rapid display of images for visualization in all type of educational classes. Visualization is a

powerful activity that can improve children's comprehension skills and encourage students to participate lectures. Class would be highly interested in the lessons in which one of the visualization processes are used. Animations as well as green box technology can help learners come to understand complex ideas more easily. They have the power to gain the attention of a person for hours together without boring them.

Rapid display of images to create an illusion of movement is called animation and green box technology is simply using a green screen to create illusion with an efficient way. We made experimental works in primary and secondary schools to test the idea of visualization techniques can enhance the student's performance during lecture. Experiments and observations proved that applying of green box technology and animations improved children's comprehension skills. After we succeed in green box technology usage in education, we also prove that these technologies are not just confined to movies and video games; the areas of its application are boundless. And one of those areas is Education. Teachers can use animated video clips to explain concepts (like energy conversion, atomic movement, etc.). The process of usage of animated video clips not only makes the complex concepts clear but also helps the student's memorization skills.

This technique enable memorizing of complex scientific facts or foreign language words for a longer time with an efficient way since humans have a very good pictographic memory; the more you make use of visualization tools the better the information is stored.

Experiments of Green box technique over secondary school students were conducted at scientific event "Science is Beautiful" (14<sup>th</sup> October 2014) at METU (Middle East Technical University) Çankaya/Ankara in Turkey.

Observations of animated clips to support green box technique were made at Bumsuz Primary School (29<sup>th</sup> October 2014) Haymana/Ankara in Turkey.

Results of conducted experiments showed that this new way of learning tool "green box" provides promising solutions to enhance comprehension skills for both primary and secondary school students.

**Keywords.** Animation technology, green box technology, visualization processes, green screen for education.

## References

- [1] Betrancourt MM, Tversky BB. Effect of computer animation on users' performance: A review *Travail Humain: A Bilingual and Multi-Disciplinary Journal in Human Factors*, 63 (4) (2000), pp. 311–329

---

---

## The Build-up of a National Community of Practice in Science Teaching

*A Sporea, D Sporea*  
*National Institute for Laser, Plasma and*  
*Radiation Physics, Romania*  
*Center for Science Education and Training*  
*Romania*  
*adelina.sporea@inflpr.ro,*  
*dan.sporea@inflpr.ro*

**Abstract.** Collaborative and cooperative learning refer to a method used to achieve an educational goal as learners work together for the fulfillment of a given task [1,2]. Collaborative learning was proved to assist students to reach better achievements, to develop more effective psychological and social connections, to improve social behavior and to increase their self-esteem [3-5]. Through collaborative learning students are trained to work in group in a cooperative manner rather than in a competitive way, to construct knowledge rather and memorize information, to participate to decision making, to select the appropriate means to solve a problem, to have an increased control over the learning process, as this approach is student-centered. ICT is seen as an opportunity to promote and support collaborative learning, virtual environments, being both a tool and a medium for educational activities [6].

The project called i-BEST (Inquiry-Based Education in Science and Technology, <http://education.inflpr.ro/ro/IBEST.htm>) has as major focus the science teaching by inquiry. In the frame of this project we propose to schools

(from kindergarten to middle school) different activities supported by appropriate learning units and training kits, in the field of science of measuring, optics, acoustics, electricity. Some of the learning units are original and some are translations from European or American projects. These learning units are part of the e-learning platform we developed, the TeachScience platform, which includes also a virtual library (<http://81.181.130.13/teachscience/>).

School activities related to science learning are supported by a collaborative platform, aiming to create a nationwide community of practice (<http://81.181.130.13/ibest/>). As compared to the “classical” approach on collaborative learning, when students organized in small groups are solving a problem, in our implementation we are trying to channel the efforts of different schools, with various development and achievement levels, and spread across the country, towards the inquiry on the common science subject.

The present paper refers to two of the inquiry-based science activities we run in the context of this collaborative platform to support science teaching and learning from kindergarten to middle school. The two inquiry-based science activities (“Spring coming” and “Weather”) are described, activities designed to develop children observation, measuring and reporting skills in science classes. Technological aspects of the educational process are supported as school students are taught to build their own measuring instruments, learning in this way their operating principles.

### **Acknowledgements**

The authors acknowledge the financial support received from the grant 223/ 2012 of the Romanian Executive Agency for Higher Education, Research, Development and Innovation Funding (UEFISCDI), project “Inquiry-Based Education in Science and Technology: i-BEST”.

**Keywords.** inquiry-based science teaching, collaborative platform, e-learning.

### **References**

[1] T Lê. *Collaborate to Learn and Learn to Collaborate*, presented at Seventh World Conference on Computers in Education,

2001 Jul 29–Aug 3, Copenhagen, Denmark.

- [2] M Dooly. Constructing knowledge together, in *Telecollaborative Language Learning. A guidebook to moderating intercultural collaboration online*, M Dooly (Ed.), Peter Lang, Bern, 2008.
- [3] H An, S Kim, B Kim. Contemporary Issues in Technology and Teacher education 2008; 8 (1): 65-83.
- [4] DW Johnson, RT Johnson. Educational Researcher, 2009; 38(5), 365–379
- [5] MW Goodwin. Cooperative, Intervention in School and Clinic, 1999; 35, 29-33.
- [6] T Valtonen. *An insight into collaborative learning with ICT: Teachers’ and students’ perspectives*, University of Eastern Finland, Joensuu, 2011.
- 
-



## Science Promotion among High School Students through PhD Student Chapters

*E Salvador-Balaguer, E Irlles, F Soldevila,  
RO Torres, AD Rodríguez, M Carbonell,  
C Doñate, J Pérez  
GROC-UJI, Universitat Jaume I,  
Castelló, Spain  
salvadoe@uji.es*

**Abstract.** Over recent years science education has been in focus due to the decline of student enrolments in scientific degrees [1]. There have been many efforts to promote science not only on students but also in our societies [2]. Moreover, one of the challenges of this era is teaching science related to everyday life. As stated by Núñez [3], raising cognitive goals is not enough, we must link them to other social and human objectives. Thus, learning to learn is one of the fundamental goals of any educational project. Several trends propose conducting hands-on experiments and workshops with the participation of students to offer an active learning of science. If students are actively engaged and if their activities are closely linked to their daily live, they will learn better.

In this context, a group of PhD students of the university Jaume I of Castellón whom main research topic is optics, have created a student chapter named GOC (Group of Optics Castellon). Student chapters are groups of students that are affiliated to several international societies which main purpose is the dissemination of science. These societies give economical support to the students for the development of scientific networking and outreach activities.

Taking advantage of this funding we have collaborated with Jaume I University in several promotion activities to encourage students to join scientific careers. With our chapter, we have performed several outreach activities and workshops in which high school students learn by having fun. In particular we have organised three different workshops. On the first one, students learn about refraction, reflection and polarization. The second workshop was about kinematics, human vision and electromagnetic waves. Finally, in the third workshop they learned about light absorption and diffraction. We repeated the activities to several high

schools involving hundreds of students. In resume, it has been a successful set of workshops that have also been reported at the European Physical Society (EPS) news webpage [4].

In this communication we describe in detail the activities performed, we report the response and draw our conclusions in the basis of the response of the attendees.

**Keywords.** Hands-on experiments, Science promotion, Student Chapters.

## References

- [1] Osborne J, Dillon J. Science education in Europe: Critical reflections. King's College London, 2008.
- [2] OECD (Organisation for Economic Co-operation and Development). Encouraging student interest in science and technology studies. Paris, 2008.
- [3] Núñez J. (2000). Lo que la educación científica no debería olvidar: Rigor, objetividad y responsabilidad. 2005. <http://www.campus-oei.org/salactsi/nunez05.htm> [visited 20-Jun-2015]
- [4] e-EPS: Facts and info from the European Physical Society, 2015. <http://www.epsnews.eu/2015/03/outreach-to-high-school-student> [visited 20-Jun-2015]



## Bridging the Gap: Chemistry and Biochemistry in the Real World

*N Oliveira, CS Alves, C Miguel, D Maciel,  
H Tomás, J Rodrigues  
CQM, Universidade da Madeira,  
Funchal, Portugal  
nilsa@uma.pt, calves@uma.pt,  
cmiguel@uma.pt, dmaciel@uma.pt,  
lenat@uma.pt, joaor@uma.pt*

**Abstract.** The CQM-Centro de Química da Madeira (Madeira Chemistry Research Centre), located at the University of Madeira (UMa) in the Autonomous Region of Madeira (RAM), is a research unit supported by the Portuguese Foundation for Science and Technology (FCT). While research forms its principal focus, the Centre has always placed a lot of importance on conveying the importance of science, particularly Chemistry, to the general public. In this regard, numerous dissemination activities are executed by CQM of which the most well-known is the “A QUÍMICA É DIVERTIDA” (Chemistry is Fun) action. Although dissemination activities of this kind are readily accessible to all, a lack of interest in Chemistry is still evident amongst the general population of the RAM. In a bid to narrow this existent gap between science and society further, CQM recently launched “Bridging the Gap – Chemistry and Biochemistry in the Real World”.

A major objective of this new Science Outreach Programme is to bring science, namely Chemistry and Biochemistry, to the general population of Madeira and Porto Santo and to illustrate its importance on the socioeconomic development of the Region. The Programme is tailor-made to cater to the different needs of society. Several well-defined packages constituting a range of mostly hands-on activities are on offer through the Programme. They are designed to be accessible for people of all ages and are readily available for schools, old age homes and other interested entities. To date, several dynamic and interactive scientific initiatives have been done for scholars from primary and secondary schools, as well as for senior members of society. Thus far, the feedback from the different participating entities has been positive, with individuals displaying an increased interest in science by the end of the activities. It is through this alternative and pro-active

approach that “Bridging the Gap – Chemistry and Biochemistry in the Real World” aims to stimulate, motivate and capture people of all ages illustrating the importance of science on the development of society in general.

**Keywords.** Centro de Química da Madeira, Chemistry and Society, general public, outreach activities.

### Acknowledgements

The Fundação para a Ciência e a Tecnologia (FCT) is acknowledged for the financial support of our work (PEst-OE- UID/QUI/00674/2013).

---

---

## Chemistry is Fun: 20 Years Spreading Science in Madeira Island

H Tomás  
CQM, Universidade da Madeira,  
Funchal, Portugal  
lenat@uma.pt

**Abstract.** The first edition of the event “Chemistry is Fun” (*A Química é Divertida*), promoted by the Chemistry Department of the University of Madeira, was in 1995. After the creation of the CQM-Centro de Química da Madeira (Madeira Chemistry Research Centre), a Portuguese research unit supported by the Portuguese Foundation for Science and Technology (FCT), it became a part of the Centre’s regular activities.



Chemistry, the science of matter and its transformations, is nowadays strongly intertwined with other fields of knowledge and often goes unnoticed. “Chemistry is Fun” consists of a set of different activities aimed at showing the general public chemistry’s important contributions to our lives: not only for the economic development of society, but also for the improvement of human health and the protection of the environment.

How to generate enthusiasm for the study of chemistry in primary and secondary schools? How to increase the number of chemistry students in universities? How to help creative minds to discover the beauty of chemistry? In an effort to tackle these questions, “Chemistry is Fun” brings the public (especially the younger generation) to the University of Madeira and offers them the possibility of being engaged in multiple activities - colloquia, experimental demonstrations, competitions, visits to the research laboratories, chats with the scientists, *etc.* Over the last couple of years, this scientific dissemination event has

been carried out under the scope of the Portuguese National Week for Science and Technology, thus contributing to the national endeavour of increasing scientific literacy.

**Keywords.** A Química é Divertida, Centro de Química da Madeira, Chemistry is Fun, Chemistry and Society.

### Acknowledgements

The Fundação para a Ciência e a Tecnologia (FCT) is acknowledged for the financial support of our work (*PEst-OE- UID/QUI/00674/2013*), as well as Agência Nacional para a Cultura Científica e Tecnológica Ciência Viva for supporting the activities in the period 2006-2008.

---

---

## Nanoscience and Nanomaterials: a Science Fair Project

CS Alves, C Miguel, D Maciel, N Oliveira,  
H Tomás, J Rodrigues  
CQM, Universidade da Madeira,  
Funchal, Portugal  
calves@uma.pt; cmiguel@uma.pt;  
dmaciel@uma.pt; nilsa@uma.pt;  
lenat@uma.pt; joaor@uma.pt

**Abstract.** Nanoscience is the science associated with materials that have, at least, one dimension at the nanoscale (typically under 100nm) [1]. These materials are known as “nanomaterials” and may display behaviours that are a function of their size and shape [1]. Nanostructured surfaces that have features at the nanoscale are also considered nanomaterials. Nanomaterial applications (nanotechnology) are very broad and include uses in electronics, medicine, catalysis, energy production, agriculture, food quality, environment preservation, etc. [1]. Indeed, the impact of nanomaterials in the future is expected to be huge [1].

In this science fair project we will show several examples of nanomaterials that exist in nature (e.g., shark skin, the wings of the *Morpho* butterfly, the legs of water striders, Gecko feet hairs and the surface of the lotus flower). Through the use of simple experiments, we will try to explain how these nanostructured materials can be mimicked to produce functional materials that show structural colours, adhesiveness or superhydrophobicity (self-cleaning surfaces).

Among other things, visitors will also have the opportunity to see how *quantum dots*, which have the same chemical composition but different sizes, present diverse colours. How these special nanoparticles can help doctors in the diagnosis and treatment of diseases will be discussed. The presence of nanomaterials in products that we use in our everyday lives (e.g., toothpaste, sunscreens, antibacterial coatings, etc.) will also be highlighted. Using 3D molecular models, the chemical structure of the most well-known synthetic nanomaterials such as the bucky-ball ( $C_{60}$ ), nanotubes, nanodiamonds, etc. will be shown and will be related with their properties.

The CQM-Centro de Química da Madeira (<http://cqm.uma.pt>) devotes part of its research to the study of nanomaterials for biomedical applications. We will further show visitors our main ongoing research projects and how they are expected to contribute to the improvement of the well-being of society.

**Keywords.** Bioinspired materials, nanomaterials, nanoscience, nanostructured materials.

### Acknowledgements

The Fundação para a Ciência e a Tecnologia (FCT) is acknowledged for the financial support of our work (PEst-OE- UID/QUI/00674/2013).

### References

- [1] Hornyak GL, Dutta J, Tibbals HF, Rao AK, Introduction to Nanoscience. Boca Raton: CRC Press; 2008.
- 
-



## AUTHOR INDEX







- Abreu S 184, 241  
Aguín-Pombo D 131, 138, 209  
Almeida A 258  
Almeida MJ 237, 238, 239  
Almeida-Aguiar C 237, 238, 239  
Alves A 237,  
Alves CS 250, 265, 267  
António JC 228  
Azevedo J 138  
Azevedo MM 251  
Aziz-Khan M 204  
Baioa A 255  
Balta N 227  
Banerji A 255  
Barata S 226  
Belaga V 244  
Bento AV 138  
Blanco J 175  
Boal-Palheiros I 144, 240  
Borges R 255, 256  
Brazão P 156  
Camacho L 166, 257  
Carbonell M 264  
Carvalho-Pires HC 170  
Castro D 175  
Cavaquinho V 256  
Ceylan E 222, 246  
Chacón C 249  
Cláudio AF 240  
Condesso M 258  
Costa MFM 87, 124, 188  
Costa-de-Oliveira S 251  
Coutinho J 240  
Dale Tunnicliffe S 30  
Dasgupta-Misra K 230  
Dionisis V 259  
Doñate C 264  
Dorrío BV 18, 175  
Dörschelln J 255  
Elias C 236  
Encarnação F 79, 223  
Esteves Z 188  
Fernandes E 70, 161, 184, 217, 241  
Fernández D 175, 256  
Ferreira J 237, 239  
Ferreira JNM 166, 257  
Ferreira P 231  
Ferreira-Teixeira S 225  
Fidalgo R 193, 197  
Firdaus-Nawawi M 204  
Firssova O 224  
Forjaz MA 237, 238, 239  
França A 138  
Freire M 240  
Freitas R 255, 256  
Garapa M 166, 257  
Gouveia-Reis D 95  
Grynova M 35  
Güvez H 254  
Guzmán AM 249, 261  
Horta C 209  
Irlés E 264  
Jeremias M 110, 251  
Kamış T 254  
Karachalios J 259  
Kaya A 227  
Kazachkov A 35, 218  
Kechechyan A 244  
Kireš M 218  
Klygina K 244  
Komarova A 244  
Kumar-Srivastava P 259  
Kumar-Tyagi B 37, 233  
Lello A 258  
Lima-Marinho AS 201  
Lopes PC 70, 241  
Lorenzo-Álvarez S 18  
Loureiro J 231  
Machado A 236  
Maciel D 250, 265, 267  
Maciel M 237, 238  
Marques CMJM 228  
Marques J 237, 239  
Martins S 161, 241  
Martins V 124  
Medeiros y Araujo C 201  
Mendonça S 95  
Michaelides PG 1  
Miguel C 250, 265, 267  
Miranda IM 251  
Mitsou G 259  
Monro F 249  
Moor JC 35  
Moreira A 124  
Moreira H 193, 197  
Mota B 225  
Motius E 204  
Moura A 256  
Nobre A 238  
Oliveira N 250, 265, 267

Ornelas M 209  
Panebrattsev Y 244  
Peixoto B 117  
Pereira ML 218  
Pereira S 117  
Pérez J 264  
Pernar J 220  
Pescada J 256  
Pestana-Gouveia MFB 156  
Pina-Vaz C 251  
Pinheiro L 236  
Pinho R 193, 197  
Pinto-Mina IA 170  
Pombo P 226, 258  
Prado X 18, 49, 260  
Prasar V 37, 233  
Prinsen F 224  
Ramírez C 249  
Rebello H 131  
Rocha R 258  
Rodrigues AG 251  
Rodrigues J 250, 265, 267  
Rodríguez AD 264  
Sadovsky D 244  
Salvador-Balaguer E 264  
Sánchez XR 18  
Santander-Prat K 248  
Santiago A 236  
Santos S 256  
Santos TM 218, 245  
Seixas S 79, 110, 150, 223, 251, 252  
Serdar C 222, 246  
Serra F 87  
Serra M 226  
Sianoudis I 259  
Sidorov N 244  
Silva AP 251  
Sobaci E 261  
Soldevila F 264  
Sousa C 207  
Sousa F 117  
Sousa L 61  
Souto C 258  
Souto L 193, 197  
Specht M 224  
Sporea A 254, 262  
Sporea D 254, 262  
Srivastava A 243  
Srivastava PK 235  
Suarez A 224  
Şükrüye ER 181, 253  
Tavares F 193, 197  
Teixeira-Santos R 251  
Teodósio M 150, 252  
Tomás H 250, 257, 265, 266, 267  
Torres RO 264  
Trna J 25  
Trnova E 103  
Ulrich Y 236  
Varela P 87, 124  
Vildósola-Tibaud X 248  
Vladescu E 253  
Vovk R 35  
Yılmaz O 254

This book is conformed of a set of works presented at the 12th International Conference on Hands-on Science held in Madeira Island capital city of Funchal in Portugal, July 27 to 30, 2015. The editors would like to acknowledge these endorsements and sponsors as well as the efforts of the conference organizers and the members of the conference committees and the contributions of all conference participants.

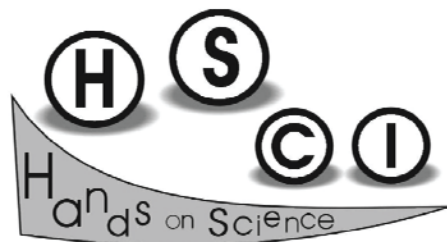

# HSCI2015

## 12<sup>th</sup> International Conference on Hands-on Science *Brightening our future*

27<sup>th</sup>-30<sup>th</sup> July 2015

Escola Secundária Francisco Franco, Funchal, Madeira Island, Portugal

### Chair:

Manuel Filipe Pereira da Cunha Martins Costa (Portugal)

### International Advisory Committee:

Abhay Kothari (India)	Maria Inês Nogueira (Brazil)
Alex Kazachkov (Ukraine)	Maria de Jesus Gomes (Portugal)
Alicia Fernandez Oliveras (Spain)	Maria Teresa Malheiro (Portugal)
Amit Garg (India)	Marian Kires (Slovakia)
Ann Torsted (Denmark)	Maxim Tomilin (Russia)
António Carlos Pavão (Brazil)	Mikiya Muramatsu, (Brasil)
Armando Dias Tavares Jr. (Brazil)	Mourad Zghal (Tunisia)
Clementina Timus (Romania)	Mustafa Erol (Turkey)
George Kalkanis (Greece)	Nilgün Erentay (Turkey)
Elisabetta Zibetti (Italy)	Panagiotis Michaelides (Greece)
Elsa Fernandes (Portugal)	Paulo Brazão (Portugal)
Erik Johansson (Sweden)	Paulo Idalino Balça Varela (Portugal)
Eva Trnova (Czech Republic)	Pedro Pombo (Portugal)
Fernanda Gouveia (Portugal)	Pradeep K. Srivastava (India)
Francisco Sousa (Portugal)	Radu Chisleag (Romania)
Helena Tomás (Portugal)	Roger Ferlet (France)
Horst Bannwarth (Germany)	Samar Darwish Kirresh (Palestine)
Iryna Berezovska, (Ukraine)	Sonia Seixas (Portugal)
Jesus Blanco (Spain)	Stephen M. Pompea (USA)
Jose Benito Vazquez-Dorrio (Spain)	Sue Dale Tunnicliffe (UK)
José Manuel Baptista (Portugal)	Suzanne Gatt (Malta)
José Figueiredo (Portugal)	Teresa Kennedy (USA)
Joseph Trna (Czech Republic)	Toyohiko Yatagai (Japan)
Liu Xu (China)	Vasudevan Lakshminarayanan (Canada)
Lucian Vladescu (Romania)	Walburga Bannwarth-Pabst (Germany)
Manuel Filipe Costa (Portugal)	Zuzana Ješková (Slovakia)

### Chair of Local Organizing Committee:

Pedro Pombo (Portugal)

### Local Organizing Committee:

Agustin Freitas	Joana Reis	Pedro Pombo
Ana Peso	João Silva	Regina Sousa
Ana Rodrigues	Jorge Costa	Rosa Canha
Carla Miguel	Jorge Godinho	Rui Branco
Cristina Lopes	Jose Vazquez-Dorrio	Rui Neves
Dulce Ferreira	Manuel Costa	Sofia Barata
Elsa Fernandes	Marta Condesso	Sofia Simões
Emanuel Garcês	Miguel Cardoso	Sofia Teixeira
Fernanda Gouveia	Miguel Serra	Sónia Abreu
Helena Tomás	Paulo Brazão	Sónia Martins
Isabel Correia	Paulo Tavares	Teresa Pereira





ISBN 978-989-8798-01-5

