

# HSCI2009

Proceedings of the  
6<sup>th</sup> International Conference on

## Hands-on Science

Science for All: Quest for Excellence

October 27-31, 2009  
Science City, Ahmedabad, INDIA





## PREFACE

The Hands-on Science Network was established in the sequence of the “Hands-on Science” project partially financed by the European Commission in the frames of the Socrates/Comenius3 program, from October 2003. Nowadays the Hands-on Science Network is a non-profit international organization legally registered in Portugal. It enrolls over 200 institutional members, and many excellent and most welcomed individual contributions, from the most EU countries but also from all over the world. With a broad open understanding of the meaning and importance of Science to the development of our societies, each individual and of the humankind, the main goal of the Network is the development and improvement of science education and scientific literacy by an extended use of investigative hands-on experiments based learning of Science and its applications, while promoting extend cooperation and mutual understanding and respect among its members within our societies.

The future development of our nations demands a strong and sustainable improvement of our scientific research and its technological applications. The recent global crisis have shown that the globally good level of scientific and technology research, specially at academic level, might be not enough to ensure a sustainable growth of our economies and society in this globalised world. The results of our scientific advances must be translate into the processes in our industrial and other services and production companies but also relate to our society' everyday lives. On this aim one must ensure a good enlarged science literacy at all levels of our society and a sound and effective science education at the school but also in informal and non-formal contexts. Furthermore enlarged cooperation in these fields should be sought as widespread as possible growing from different and diverse experiences perspectives and cultures.

“Science for All. Quest for Excellence” the main *motto* of our 6<sup>th</sup> International Conference on Hands-on Science was chosen in this perspective. The excellent facilities of Science City in India's Gujarat state capital Ahmedabad, will provide the right environment for an enlarged open-minded and positive exchange of experiences leading to substantive conclusions that will surely contribute to our higher common goal

aiming excellence by providing *SCIENCE FOR ALL*

As Chair of the conference and President of the International Association Hands-on Science Network it is my pleasure to welcome you to HSCI2009 wishing you a wonderful stay in Ahmedabad!

Braga, October 2, 2009.

Manuel Filipe Pereira da Cunha Martins Costa  
**Chair**





भारत सरकार  
विज्ञान और प्रौद्योगिकी मंत्रालय  
विज्ञान और प्रौद्योगिकी विभाग  
टेक्नोलॉजी भवन, महरौली मार्ग  
नई दिल्ली-110 016

GOVERNMENT OF INDIA  
MINISTRY OF SCIENCE AND TECHNOLOGY  
DEPARTMENT OF SCIENCE AND TECHNOLOGY  
TECHNOLOGY BHAVAN, NEW MEHRAULI ROAD  
NEW DELHI-110 016



Telegram : Scienctech  
दूरभाष/Tel : 26962819, 26567373,  
26562134, 26562122 (EPBAX)  
फैक्स/Fax : 26569908, 26864570,  
26863847, 26862418

October 19, 2009

## FOREWORD

Effective communicators are those who can convey novel ideas to their audience. The sequence of increasing depth of description and explanation should be rewarding to the interested 'explorers'. Methods of doing this require research by the best minds drawn from a wide spectrum of disciplines. Hands on Science Network has been catalyzing development of this fascinating process at a time when traditional forms of communication are being supplemented with technologies of the future.

I convey my greetings to the delegates of 6th International Conference on 'Hands on Science' being organized at Gujarat Science City, Ahmedabad in October, 2009 and wish the deliberations all success.

(ANUJ SINHA)  
Scientist "G" & Head  
Science Communication



## INTRODUCTION

The 'Hands-on Science' being a sub-set of the broader set of 'Science Communication' carries the inherent concept of promoting creativity and innovation through learning by doing and putting things together with more accuracy and precision with better understanding. The activity and creativity oriented Hands-on Science experience can lead to synchronisation of head and hands together to achieve excellence in any walk of life. However, this practise did not gain much ground and has remained limited to those who are willing to put those extra efforts to the advancement of science and technology. This is where scientific and technological culture needs to be emphasized. 'Hands-on Science Movement' is an effort in this direction.

India has a long tradition of such activities, be it tribal metallurgy, medieval craft, creative exhibits, demonstration of science experiments, or sophisticated innovations. The Scientific Society of Aligarh founded by Sir Sayed Ahmed in beginning of second half of nineteenth century had acquired a piece of land to experiment modern agricultural techniques and demonstrate agricultural practices to farmers. According to Habib (1985), one of the major activities of the Scientific Society, was organizing popular lectures-cum-demonstrations on topics of popular and academic interest which included history, philosophy, mathematics, mechanics, agriculture and natural sciences, etc. Father Lafont had organized a series of public exhibitions of science models, lectures and demonstrations on new scientific inventions, like telegraph and telephone, etc., at St. Xavier's College, Calcutta in 1886, which was a remarkable effort of 'Do-it Yourself' exhibits, recreated for the purpose.

An unsung hero and pioneer of science popularization Hargulal, a science teacher at Ambala, has contributed tremendously in the area of science teaching-learning aids during mid nineteenth century (1857). He had fabricated various scientific models, toys, designed posters and eventually started lecture-cum-demonstrations and exhibitions of his low-cost models among children and common audience for popularizing basic principles of science in different parts of the country. As the demand of science models and posters/ charts increased, he started mass production of different models and was able to export them. He also fought and won a court case against a Bombay based industrialist, who was trying to sell and export Lal's scientific instruments and models under his own name. Hargulal got compensation for the same (Patairiya 1997).

According to Sehgal et al (1994), Ruchi Ram Sahni was a multi-faceted personality, a scientist, an innovator, an educationist, a patriot and a devoted social worker and science communicator. He started his career as Second Assistant Reporter to the Government of India in the Meteorological Department in 1885. One of his major achievements was the creation of scientific awareness amongst the common man of Punjab state. Those days, Punjab also consisted of the present day Punjab in Pakistan and some parts of Himachal Pradesh and Haryana. His efforts for science popularization are credited to be the first, besides some similar efforts in Bengal. He co-founded the Punjab Science Institute, with Professor J. Campbell Oman. Popular lectures on various aspects of science organized under the auspices of the Punjab Science Institute created lot of enthusiasm as people did not mind paying a small fee for science lecturers to Moffussil places. Probably this was the earliest instance in India of common people paying for popular science lectures and Hands-on Science demonstrations. On realizing the fact that no science teaching was possible without simple scientific instruments, he established a workshop as part of the Punjab Science Institute for repairing and manufacturing scientific apparatuses by spending his own resources. He also trained young people enabling them to follow the legacy of Hands-on Science experiments for science education.

The 6<sup>th</sup> International Conference on Hands-on Science is aimed at furthering the culture of innovation and experimentation. This conference shall be the mechanism for the experts and

practitioners of the thought to be together in India and forge ahead towards achieving the goal of higher degree of innovativeness and skill appreciation in the societies across the world. India shall specifically be benefited by this Conference, as people working in this area shall have an opportunity to directly interact with the similar experts from across the world. The interaction shall be through sharing of knowledge in the form of presentation of views, experiences, research papers, results of researches, surveys, data analysis, etc., in the area. There are components of invited talks, exhibition, activity corners, displays, posters, cultural performance, etc. This is for the first time that such an international conference is being organized in India. This conference is sixth in series and is designed for the participants from all possible interest groups including government agencies, universities, science and technology R&D institutions, learned and professional societies, organisations working for the cause.

Hands-on Science has been emphasised by the experts and proponents of popularisation of science skill culture. Several organisations, groups and experts have been working in their own knowledge spheres and achieving results, which are encouraging. Hands-on science has been a movement in various parts of the world for making science communication and education more effective, besides enhancing skill and innovation level in the societies. This conference is a step forward in accelerating this movement. The major outcome of the HSCI-2009, amongst others, would be in the form of "Hands-on Science India Declaration 2009" to guide us towards the future course of action in chalking out coordinated efforts in achieving the goal of "Science for All : Quest for Excellence", which is also the focal theme for HSCI-2009.

On behalf of the Organizing Committee, I welcome all the delegates who have come all the way from different parts of the world covering 25 countries, over 300 delegates, including 75 international delegates belonging to different specialised groups, i.e. scientists, technologists, science policy makers, science administrators, science communicators, educationists, journalists, researchers, teachers and students, who will be presenting over 200 research papers, review papers, case studies, survey analyses, workshops, exhibits and talks, etc. I thank with great sense of gratitude to one and all, who have contributed to the organization of HSCI-2009, especially the Govt. of India, Gujarat Council of Science City, Science Technology and Development Initiative, and International Centre for Science Communication. I also extend our sincere thanks to the International Association Hands-on Science Network (HSCI Network) for giving us the opportunity for hosting HSCI-2009 conference in India. I wish a comfortable stay to all delegates and hope to have a thought provoking and fruitful Conference.

Manoj Patariya

***Vice Chair***

Director (Scientist 'F')

National Council for Science & Technology Communication

Department of Science & Technology, Govt. of India

Technology Bhavan, New Delhi-110016, India

Phone : +91-11-26537976; Fax : 26866675

E-mail : manojpatariya@yahoo.com; mkp@nic.in

Website : [www.dst.gov.in](http://www.dst.gov.in); [www.hsci2009.org](http://www.hsci2009.org); [www.iscos.org](http://www.iscos.org); [www.iswaindia.com](http://www.iswaindia.com)



HSCI2009  
Proceedings of the  
6<sup>th</sup> International Conference on Hands-on Science  
Science for All. Quest for Excellence  
27th – 31st October, 2009  
Science City, Ahmedabad – 380360 (Gujarat) India  
ISBN 978-989-95095-5-9  
*Online available on <http://www.hsci.info>*

**Under the High Patronage of:**

Shri Prithviraj Chavan, Hon'ble Union Minister of State (Independent Charge)  
Ministry of Science & Technology and Ministry of Earth Sciences, Govt. of India

**Advisors:**

Prof. CNR Rao, Chairman, SAC-PM	Prof. M.S. Swaminathan, MSSRF
Dr. R. Chidambaram, Scientific Adv.to Govt. of India	Prof. S.K. Joshi, Emeritus Scientist
Prof. V.L. Chopra, Member S&T, Planning Commission	Dr. H.K. Gupta, Distinguished Scientist
Dr. Sailesh Naik, Secretary, Ministry of Earth Sciences	Prof. Yash Pal, National Professor
Prof. V.S. Ramamurthy, Raja Ramanna Fellow	Dr. T. Ramasami, Secretary, DST
Dr. Sam Pitroda, Chairman, Knowledge Commission	Dr. M.K. Bhan, Secretary, DBT
Dr. Narender K. Sehgal, UNESCO Kaling Award Winner	Dr. Sameer Brahmchari, Director General, CSIR
Dr. D. Balasubramanian, UNESCO Kaling Award Winner	Dr. Saroj Ghosh, Adviser, Gujarat Science City
Dr. J.V. Narlikar, UNESCO Kaling Award Winner	Prof. D.P. Singh, VC, BHU

**Chair:**

Manuel Filipe Pereira da Cunha Martins Costa (Portugal)

**Vice-Chairs:**

Manoj K. Patairiya (India)

**International Advisory Committee:**

Abhay Kothari (India)	Adelina Sporea (Romania)	Anand Asundi (Singapore)
Andre Koch Torres (Brazil)	Anna Pascucci (Italy)	António Carlos Pavão (Brasil)
Charlotte Holtermann (Denmark)	Clementina Timus (Romania)	Daniel Gil Pérez (Spain)
Deidre Knox (Ireland)	Eliina Jussila (Finland)	Elsa Hogert (Argentina)
Erik Johansson (Sweden)	Eva Ramon Gallegos (Mexico)	Francisco Esquembre (Spain)
François van Cuyck (France)	Fernando Ribeiro (Portugal)	George Kalkanis (Greece)
Gita Senka (Latvia)	Hai-Ning Cui (China)	Hanna Tom (Estonia)
Hans Fibi (Austria)	Hector Rabal (Argentina)	Horst Bannwarth (Germany)
Hugh Cartwright (UK)	Iryna Berezovska (Ukraine)	Ivan Gerlic (Slovenia)
Joaquim Carneiro (Portugal)	John Bartzis (Greece)	Jose Miguel Zamarro (Spain)
Joseph Trna (Czech Republic)	Karl Sarnow (Belgium)	Kim Chew Ng (Australia)
Korado Korlevic (Croacia)	Lászlo Fuchcs (USA)	Marki Lászlo (Hungria)
Manoj K. Patairiya (India)	Manuel Armando Pereira (Portugal)	Marcelo Trivi (Argentina)
Maria Conceição Abreu (Portugal)	Maria de Jesus Gomes (Portugal)	Marian Kires (Slovakia)
Mario Belloni (USA)	Mariolina Tenchini (Italy)	Mário Pereira (Portugal)
Maxim Tomilin (Russia)	Monica Landau (Argentina)	Mustafa Erol (Turkey)
Nestor Gaggioli (Argentina)	Nilgun Erentay (Turkey)	Pedro Membiela (Spain)
Peter Csermely (Hungary)	Radu Chisleag (Romania)	Richard Pinner (UK)
Roger Ferlet (France)	Sabry Abdel-Mottaleb (Egipt)	Sónia Seixas (Portugal)
Srdjan Verbic (Serbia)	Svein Sjøberg (Norway)	Tina Overton (UK)
Vasco Teixeira (Portugal)	Wolfgang Christian (USA)	Yuri Senichenkov (Russia)

**Program Committee:**

Manuel Filipe Costa (Portugal)	Abhay Kothari (India)	Mikiya Muramatsu (Brazil)
Armando Tavares (Brazil)	Jose Benito Vazquez Dorrio (Spain)	Raquel Reis (Portugal)
Panagiotis Michaelides (Greece)	Dan Sporea (Romania)	Sasa Divjak (Slovenia)
Costas Constantinou (Cyprus)	Eleni Kiryaki (Belgium)	Roger Ferlet (France)
Suzanne Gatt (Malta)	Cacilda Moura (Portugal)	Walburga Bannwarth (Germany)

HSCI2009  
Proceedings of the  
6<sup>th</sup> International Conference on Hands-on Science  
Science for All. Quest for Excellence  
27th – 31st October, 2009  
Science City, Ahmedabad – 380360 (Gujarat) India  
ISBN 978-989-95095-5-9  
*Online available on <http://www.hsci.info>*

**National Advisory Committee:**

**Patron:**

Dr. T. Ramasami, Secretary, Dept. of Science & Technology, Govt. of India

**Chair:**

Er. Anuj Sinha, Scientist G & Head, NCSTC/ DST

**Vice Chair:**

Dr. Manoj Patairiya, Scientist F, NCSTC/ DST

**Members:**

Dr. V.B. Kamble, Director, Vigyan Prasar  
Prof. M.A. Ansari, GB Pant Univ. of Agricult. & Techn.  
Dr. R. Sridhar, Director, CEMCA  
Mr. Y. Mathur, UNICEF  
Dr. Ashok Kumar, UNESCO  
Prof. Anil Gupta, IIM-A  
Ms. Shubhra, Nature India  
Ms. T.V. Padma, Scidevnet  
Dr. K. Surya Rao, President, SWATI  
Dr. V.K. Srivastava, Sr. DDG, ICMR  
Dr. S.K. Grover, DDG, Doordarshan  
Prof. H.C. Pradhan, H.B. Centre for Science Education  
Dr. Krishna Kumar, Director, NCERT  
Dr. Yatish Agrawal, Safdarjung Hospital  
Dr. Krishna Lal, Scientist Emeritus, CSIR  
Dr. B.C. Agarwal, Director, TALEEM  
Mr. Bishoi, Director, Ministry of Communication, GOI

Mr. Neeraj Sharma, Scientist G, NEB-DST  
Smt. Ira Joshi, Director, I&B, GOI  
Dr. Madhu Pant, Bal Bhawan  
Mr. N.K. Sharma, NRDC  
Dr. Arvind Gupta, Science Educator  
Dr. P. Iyemperumal, TNSTC  
Dr. A.S. Rao, TePP, DSIR  
Dr. M. Hota, Jt. Director, Ministry of Environ. & Forests, GOI  
Prof. T.C. Kandpal, IIT-D  
Prof. B.K. Patnayak, IIT-K  
Dr. Ashok Jain, NISTADS  
Dr. Arun Kulshershta, NAM Centre  
Dr. A. Mitra, INDO-US S&T Forum  
Dr. S.N. Sharma, CSIR  
Mr. R.K. Sahay, CSIR  
Dr. R.D. Sharma, ISWA  
Dr. K. P. Nautiyal, President, STAD

**Local Organizing Committee:**

**Chair:**

Mr. Raj Kumar, IAS, Secretary, Dept. of Science & Technology, Govt. of Gujarat

**Vice Chair:**

Mr. Ashok V. Mehta, Executive Director, Gujarat Science City

**Members:**

Dr. D.K. Pandey, Scientist E, NCSTC/ DST  
Mr. B.K. Tyagi, Scientist D, Vigyan Prasar  
Mr. Vikas Mishra, Kanpur University  
Prof. A.P. Singh, Lucknow University  
Mr. Tarun Jain, Science Journalist

Mr. DK Rao, Gujarat Tourism  
Er. L. D. Kala, IIT-D  
Mr. V.P. Singh, ISCOS  
Mr. Tariq Badar, HRDC  
Mr. PP Singh, MCNUJC

Mr. Abhay Kothari, MANTHAN  
Dr. Y. Balamuralikrishna, UNI  
Mr. MA Mohanti, Science City  
Dr. AM Prabhakar, GujCOST  
Dr. RK Sahoo, Kankaria Zoo

**Secretariat:**

Dr. Narottam Sahoo, Executive Scientist, Gujarat Science City

# HSCI 2009

Proceedings of the  
6<sup>th</sup> International Conference on Hands-on Science  
Science for All. Quest for Excellence  
27th – 31st October, 2009  
Science City, Ahmedabad – 380360 (Gujarat) India

Edited by

**Manuel Filipe Pereira da Cunha Martins Costa (Universidade do Minho)**

**José Benito Vázquez Dorrío (Universidade de Vigo)**

**Manoj K. Patariya (NCSTC)**



---

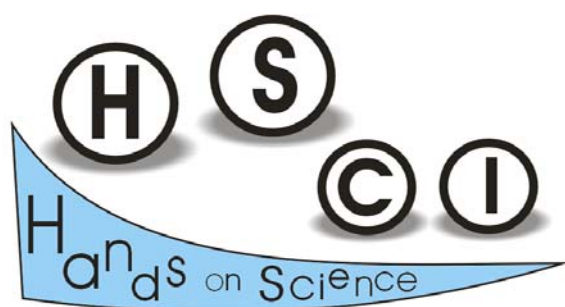
The Hands-on Science Network acknowledge these sponsorships and collaborations



---

The Hands-on Science Network





Copyright © 2009 H-Sci

ISBN 978-989-95095-5-9

Printed by: Science City, Ahmedabad, Gujarat, India.

Number of copies: 500

First printing: October 2009

Distributed worldwide by *The Hands-on Science Network* - [mfcosta@fisica.uminho.pt](mailto:mfcosta@fisica.uminho.pt)

Full text available online at <http://www.hsci.info>

The papers published in this book compose the Proceedings of the 6<sup>th</sup> International Conference on Hands-on Science. Papers were selected by the Conference Committees to be presented in oral or poster format, and were subject to review by the editors and program committee. They are exclusive responsibility of the authors and are published herein as submitted, in interest of timely dissemination.

Please use the following format to cite material from this book:

Author (s). Title of Paper. Proceedings of the 6<sup>th</sup> International Conference on Hands-on Science. Costa MF, Dorrío BV, Patairiya MK (Eds.); 2009, 27-31 October; Science City, Ahmedabad –India. 2009. Page numbers.

The authors of this book, the Hands-on Science Network, the organizers and the sponsors of the HSCI2009 Conference, none of them, accept any responsibility for any use of the information contained in this book.

All rights reserved.

Permission to use is granted if appropriate reference to this source is made, the use is for educational purposes and no fees or other income is charged.

## PREFACE

Manuel Filipe Pereira da Cunha Martins Costa

## FOREWORD

Anuj Sinha

## INTRODUCTION

Manoj Patairiya

## CONTENTS

<b>Science Communication through Digital Media: An Indian Perspective</b>	
M. Patairiya	1
<b>Learning Science in Informal Environments</b>	
Bruce B. Lewenstein	10
<b>New Ways to Learn Science with Enjoyment – Robotics as a Challenge</b>	
A.F. Ribeiro	15
<b>Day to Day Optics – An Overview of Science Activities About Optical Phenomena for High School Students Developed in the City of Ribeirão Preto – Brazil</b>	
L. Bachmann and L.B. Mostaço-Guidolin	24
<b>Callus Induction from Different Parts of <i>Nigella sativa</i> L. Seedling under Stress Conditions</b>	
I. Zareeen Ahmad, A. Kamal and N. Fatima	30
<b>Science Communication through Hands-On Activities</b>	
P. Iyamperumal	31
<b>“The Earth from Space” Geosciences Information for Teachers (Gift) Workshop</b>	
M. Szepesi and C. Stefureac	39
<b>Solar Energy Workshops for Technical Students</b>	
J. Diz-Bugarín and M. Rodríguez-Paz	40
<b>Who Are Our Ancestors?</b>	
P.S. Bhavisha, B.M. Viralkumar, M.J. Vibhuti., M.B. Yogesh and S.T. Vrinda	45
<b>Building a Secure Data Warehouse for e-Governance</b>	
V.N. Jokhakar	50
<b>Rich Internet Applications in Education</b>	
S. Divjak	53
<b>New Era of Genetics: Good to Superior</b>	
B.M. Viralkumar, P.S. Bhavisha, M.J. Vibhuti, M.B. Yogesh and S.T. Vrinda	57
<b>Cartoon for Communicating Science – An Emerging Trend</b>	
A. Ray and A. Dutta	60
<b>Environmental Interpretation in Forest Urban in PUC Mina</b>	
A.C. Sanches-Diniz, L.P. da Rocha Afonso and J.A. Leite-Dutra	71
<b>Support Material for In-school Hands-on Experiments</b>	
B. Rangachar	78
<b>The Creation and the Creator: A Rewarding Experience in a Functional Neuroanatomy Teaching Course</b>	
M.I. Nogueira, W. Allemandi, C.A. Chiroso-Horie, C. Sitamoto and S. Sitamoto	83
<b>Hands-On Optics: Training Courses For School Teachers</b>	
M.F.M. Costa and B.V.Dorrio	89
<b>Experimental Models of Urban Sustainability Based on Indicators</b>	
M. Sasek-Divjak	94

<b>High Volume Fly Ash Concrete: An Innovative, Cost Effective and Eco-Friendly Revolution in Construction Industry</b>	
S.K. Chaudhary	99
<b>Family Hands-on Activities in Science and Technology Education for All: Gifted and Ungifted, Children and Adults</b>	
J. Trna and E. Trnova	105
<b>Role of Household Chemicals in Recycling</b>	
R.W. Sugumar and T. Jabapriya	110
<b>Communicating Science through ICT: A study of VKC's in Puducherry</b>	
D. Jayaprakash	115
<b>Utilisation of Fly Ash in the Construction of Roads and Embankments</b>	
S.K. Chaudhary	123
<b>Alteration in Antibacterial Potential of <i>Nigella sativa</i> L. Seed During Different Phases of Germination</b>	
I. Zareen Ahmad, A. Kamal and J.M. Arif	129
<b>Promotion of Scientific and Technological Temper</b>	
G. Shankar	130
<b>Effective Science Communication Practices and Simple Hands-on Activities: Two Important Elements of Teacher Professional Development</b>	
S. Perera	134
<b>Development of Soft and Hard Materials with Engineered Microstructures: Some Simple, Hands-on Techniques for Synthesis</b>	
G. Banerjee and D. Sanyal	139
<b>Physics Models to Estimate Averages and Errors on Quantities Used in Economics</b>	
I.R. Chisleag Losada and R.Chisleag	144
<b>Sonochemical aldol condensation using copper perchlorate as catalyst in solventless media</b>	
S. Puri, B. Kaur, A. Parmar and H. Kumar	146
<b>Multi Purpose Teaching Aid</b>	
P. Pati	150
<b>Inter-relations Robot – Renewable Energies: A Science/Technology/Society/Environment Methodological Educational Approach</b>	
S. Oliveira e Sá, M.A. Pereira dos Santos and M.F.M. Costa	152
<b>Knowledge As A Service (KaaS) by Using A Modern Knowledge Based System Through Reusable Components</b>	
T. Shah	154
<b>Wireless embedded control system for home automation</b>	
H.J. Lad and A. S. Chaudhari	157
<b>Pedagogical Material that Promotes Students Interest in Science</b>	
S. Carreira-Leal and J.P. Leal	161
<b>Astronomy with an 8-Inch</b>	
R.K. Bhattacharyya	165
<b>Community Science Centers and Hands on Science</b>	
A.M. Prabhakar	170
<b>Information: Is Information Technology Progress Enabling Cyberchondria?</b>	
I. Berezovska and K. Buchinger	175
<b>CLIP – Child Learning Improvement Program</b>	
K.S. Chandra and N. Kamalesh	180
<b>An Interactive Educational Environment for Teaching Psychoacoustics</b>	
C. Mousas, A. Floros, M. Arvanitis and T.V. Ionian	187
<b>Introducing Optics in the Kindergarten</b>	
M.F.M. Costa, J. Ayres de Campos, M. Lira and S. Franco	193

<b>Robotics in Child Storytelling</b> C.R. Ribeiro, M.F.M. Costa and C.Pereira-Coutinho	198
<b>Biomaterial Moisture Sensor</b> P. S. More, V.V.Kshirsaga.R, H. R. Khambayat, C.S.Ghuge, A. V. Shelke, A.R.Junghare, A.U.Ubale and S.S. Borwar	205
<b>Science Fairs in Non-Disciplinary Curricular Areas</b> Z Esteves and M.F.M. Costa	210
<b>Advanced Multi-layer Model for Information Security in e- Governance</b> S.A. Chaudhari	214
<b>Derive to Retrieve: Bioinformatics</b> M.J. Vibhuti, P.S. Bhavisha, B.M. Viralkumar, M.B. Yogesh and S.T. Vrinda	220
<b>The World of Marine Life Forms Based on Discards of Fishing</b> A. Venkateswararao	224
<b>Inculcating Scientific Temper among the Students of Sapuipara Janata Adarsh Vidyalaya</b> S.S. Ghosh	225
<b>Interacting Education Regarding Environment Protection and Self- Willing Encouragement</b> R. Busa, F. Cimpoca, D. Vladu, L. Andrei and M. Enache	230
<b>Recovery of Silver in Laboratory Residual Suspensions</b> A.S. Machado-Ribeiro, F. do Couto Maia, R. S. Pereira-Couto and J.M. Pereira da Silva	234
<b>Impact of Fun Learning in Classroom for Science Education</b> R. Purohit	235
<b>Furthering Agricultural Education for Forthcoming Challenges</b> G. Papnai and I. Prabhakar	236
<b>Rural Knowledge Centres: Thrust of the Farmers</b> T. Ahmed, M. A. Ansari and I. Prabhakar	243
<b>Wireless Sensor Network Technologies: Opportunities and Challenges for Rural India.</b> S.V. Patel, K. Pandey and V R Rathod	247
<b>Three AMAZING Teaching Aids: Singing Cup, Gyroscope and Auto-Returning Airplane</b> T. Cheng-Ming	253
<b>Importance of Pyrimidine Derivatives in Day-to-Day Life</b> S. Das and A.J. Thakur	254
<b>How Relevant Are Our Urban Science Centres in Today's Societies?</b> R. Mehrotra	255
<b>Promotion of Scientific and Technological Temper Empowering India by creating Scientific &amp; Technological Ambiance</b> L.K. Chhaya	257
<b>“Kasish”: School Science Societies</b> P.C. Vyas	263
<b>Innovations in Teaching Physics of Sound</b> A. Garg, R. Sharma, V. Dhingra, A. Kumar and Z. Khan	267
<b>Prevention of Teenage Obesity</b> J.M. Pereira da Silva	271
<b>Communicating Science to the Tribal Communities of Assam through Hands- on Training</b> A. Dutta and A. Ray	275
<b>Diversity of Marine Life Forms Based on Discards of Fishing</b> B. Padmavathi and A. Padmaja	291

<b>Study on Phase Change with Natural Convection – A Hands-on Approach of Acquiring Insights of Complex Physical Phenomena</b>	
A. Das and D. Sanyal	291
<b>Science and Technology Communication and Science Literacy</b>	
S.J. Bute	292
<b>How Media Helps in Communicating Science- A Review Paper</b>	
A. Arora	293
<b>Reaching the Unreached Children – The Need of the Hour for Rural Schools in India</b>	
M.A.J. Rajan and A. Thaddeu	294
<b>Green Chemistry Experiments as Hands-On-Science Tools for Environmental and Green Chemistry Education</b>	
K.K. Nandi	295
<b>Creating Climate Change Awareness through Exposure Visit</b>	
I.A. Aram	299
<b>A Lifelong Learning Project for Science Teachers in Rural Region of Turkey</b>	
M. Erol and R. Sahingoz	300
<b>Make Your Own Physics Demonstrations!</b>	
Ching-Chi Chu, Tsung-Cean Tu and Hsiao-Ching Su	301
<b>Benchmarking and Testing Needs and Use: The Art and Science of Making Choices to Design IT Hardware Courses</b>	
I. Berezovska	301
<b>A Novel Green Chemistry Practice in Testing Gases</b>	
I.G. Shibi	302
<b>Popular Science Activities at National Central University, Taiwan</b>	
Ching-Chi Chu, Hsiao-Ching Su and Tsung-Cean Tu	302
<b>Access to Consumer Health Information: Changes under Influence of IT Progress</b>	
I. Berezovska and K. Buchinger	303
<b>Energy and CO<sub>2</sub> - A Common Challenge for Europe</b>	
J.F. Fernández, J.P. Santos and M.F.M. Costa	304
<b>An Experience on: How to Disseminate Scientific Knowledge to the Community</b>	
M. Martinho, S. Seixas and R. Fonseca	304
<b>Science Communication - Present Scenario and Future Trends</b>	
A.K. Agarwal	305
<b>Nature Education in 22 Steps: A Model Proposal</b>	
N. Erentay and M. Erdogan	311
<b>Faithful Secure Cloud Strategy</b>	
D. Joshi and P. Pandya	318
<b>Methodology Used to Supervise the Theses of Bachelor in Biology (Educators of Children): from Traditional Distance Education to e-Learning</b>	
S. Seixas	322
<b>Astronomy in the Service of Mankind</b>	
S.R. Verma	322
<b>Tapping our Green Gold - Seed Oils: An Insight</b>	
S. Ahmad, D. Akram, F. Zafar and E. Sharmin	323
<b>Uses of Drama as a Learning Strategy</b>	
R. Pinner	323
<b>Popularising E-Governance for Development</b>	
J.K. Sarmah	324
<b>Innovative Approaches for Diffusion of Farm Technologies at Grassroots Level</b>	
J. Saxena	324



<b>Enhancing Students' Attitude toward Science through Handson Instruction in Physics</b>	
Chung-Chih Chen, Chin-Hsueh Rd, Ta-Liao Hsiang and Kaohsiung Hsien	325
<b>Communicating Science through VRCs in Tamil Nadu and Puducherry</b>	
D. Jayaprakash	325
<b>Robotics as a Tool to Increase the Motivation Levels in Problematic Students</b>	
C.R. Ribeiro, C. Machado, M.F.M. Costa and C. Pereira-Coutinho	326
<b>Miraculous Demonstrations of Pedagogical Value to Introduce Concepts in Chemistry</b>	
S.B. Ghoderao and R.D. Kankariya	328
<b>Elucidating and Teaching the Structure of DNA to Biology Students</b>	
V.K. Adi	333
<b>Andhra Pradesh National Green Corps: Creating the Next Generation of Environmental Leader</b>	
V.Gurunadha-Rao	335
<b>A Science-Field Teaching Module with Hands-On Experiments</b>	
Chien Ho Chou, Chin Hsin Huang and Vin Son Hsieh	341
<b>Hands-on Activities of Polymer</b>	
Chien Ho Chou and Chin Hsin Huang	342
<b>Plane Potential Fields. Theoretical Notions and Experimental Modelling</b>	
I. Ionita, A.D. Mateiciuc and A. Beteringhea	342
<b>Water. A Host of Life</b>	
E. Niculescu-Mizil	342
<b>Physics Demonstrations on Dining Table</b>	
Ching-Chi Chu, Tsung-CeanTu and Hsiao-Ching Su	343
<b>Understanding Thermal Equilibrium through Hands-on Activities</b>	
S. R. Pathare, R. D. Lahane	343
<b>A Study of How Participatory Video Can Best Be Used for Developing Spirit of Innovation in Underprivileged Students Studying in High Schools</b>	
V.R. Jogi	346
<b>Prevention of Galvanic Corrosion among Metals</b>	
A. Costa-Ramalho, A.R. Almeida-Soares, D.A. de Oliveira Pinho and J.M. Pereira da Silva	347
<b>Neem Seed Oil: A Greener Alternative For Integrated Pest Management And Malaria Control</b>	
N. Devi and T.K.Maji	348
<b>Eye and Lens through Millenniums' Prism</b>	
S.K. Stafeef and M.G. Tomilin	349
<b>Challenges in Preventing H1N1 (Swine Flue) in India</b>	
K. Surya Rao	350
<b>Electro-Kinetic Phenomena Kit</b>	
D. Valeriu, Z. Florin and B. Gheorghe	351
<b>Science for Common Mass: Thoughts and Activities of Tagore</b>	
M. Mishra	351
<b>Ecological Niches as Learning Resources</b>	
L. D'Cruz	351
<b>Hands-on Science: Communication through Multi-media and ICT Tools</b>	
A.S.D. Rajput	352
<b>Transformation of Seed Oils into Polyurethaneamide Protective Materials</b>	
M. Kashif, F. Zafar and S. Ahmad	353
<b>Generating Electric Power through zind Mills in Motor Vehicles HSci</b>	
G.P. Kumar, R. Muthukumar, R. Kalaiyarasi, S. Lakshmanan, S. Venkatesan and A. Manikandan	353

<b>EUREKA! – Experimental Science Sessions in Primary Schools</b> J. Saiote, L. Carvalho, N. Ribeiro and F. Santos-Silva	354
<b>Science Popularization through School Education: The Role of Teachers and School</b> P. Kumar and P. Singh	355
<b>Lectures Plan on Recording Media Based on LC materials: a Workshop</b> M.G. Tomilin	355
<b>Portable Solar Water Purifier</b> D. Siri, and N.A. Narasimham	356
<b>A Case Studies of the Listeners Profile of Radio Science Serial</b> R.S. Yadav	357
<b>'Nahar' (Mesua ferrea) Seed-as A Source of Fuel</b> B.B. Borah, D. Borah and G. Sarma	358
<b>Catalyzing science communication through students</b> M.K. Jolly	359
<b>The Production and Analysis of the Teaching Tool for Showing Spherical Magnetic Field by Ferrofluid</b> F.U. Yan-Qing, S.U.N. Qiao, L.I.U. Zhi- Sheng and L.I. Xue-Hui	361
<b>Scientific Popularization through Scientific Explanation of Magic and Wonders</b> I. Human and R. Khan	364
<b>How Much One Can Learn by Doing Self: A Study</b> R. Khan and I. Human	364
<b>Understanding Weather and Climate through PROBE-Orissa Programme</b> B. Mohapatra	365
<b>Hands on Science in Makkal TV</b> A. S. Pandi	367
<b>Promoting the Concept of Ecoschool for Sustainable Environment in Cuddalore District of Tamil Nadu, India</b> K. Sampath	367
<b>Hands on Science: Towards Total Knowledge Transfer for S&amp;T Communication</b> L. Kala	376
<b>Hands-on Universe–Europe</b> R. Ferlet	379
<hr/>	
<b>AUTHOR INDEX</b>	381

## CONTENTS





## Science Communication through Digital Media: An Indian Perspective

M. Patairiya  
National Council for Science &  
Technology Communication  
New Mehrauli Road,  
New Delhi-110016, INDIA  
manojpatairiya@yahoo.com, mkp@nic.in

**Abstract.** Digital technology has revolutionized communication the world over and is rapidly entering into almost every sphere of human activity, be it research and development, agriculture, industry, business, education, health and medicine or even entertainment. The access of information has become comparatively easier due to advent of new digital technology, which gave birth to a full-fledged medium of communication, known as digital medium. The digital medium has a great potential for communication of science and technology, as well.

Various mass media have been employed for science communication among masses for carrying scientific messages and scientific information to every nook and corner of the country. These mass media included, among others, print (newspapers, magazines, books, etc.); electronic (radio and television); folk (street plays, puppetry, folk songs, theatre, etc.) and interactive/participatory (seminars, workshops, exhibitions, museums, etc.). The emergence of new digital media has opened new vistas in communication and has left all these communication media behind, in terms of fingertip access, variety and quality of information.

Taking advantage of the potential that the digital media carries a variety of short term training programmes were conducted by the author in different parts of the country over last 5 years. The analysis of the responses collected from 1250 participants of 50 such programmes was studied for the efficacy, acceptance and reach of digital media and interesting inferences drawn. These training programmes had focus on skill and capacity development for using digital media for dissemination of science contents to various target groups. The participants to these training courses are scientists, journalists,

writers, NGO activists, teachers and science communication professionals. The paper discusses, besides others, the general terminologies of Information Communication Technology (ICT), their applications in science communication and popularization, including futuristic perspectives.

### 1. Introduction

Although, every medium has its own merits and demerits. When TV appeared on the scene, people were so excited about it since it was considered that advent of TV will wipe out the hold of radio. But radio remained popular even after the arrival of number of satellite TV channels. Similarly, there are certain apprehensions about digital media that whether this will affect the popularity of already prevalent mass media! It appears from the past experience, that no media can replace the existing one, just because of its newness. Moreover, in our diversified socio-economic culture, we need all the media together to communicate more effectively and more widely. In view of the great potential of the newly emerging digital media, it can be hoped that, it will definitely complement other media, to make them more informative, more up-to-date and more enriched, to better serve the target audiences.

The 20<sup>th</sup> century had seen the changing scenario of traditional communication media into modern communication media. A few steps ahead of folk forms, print and written medium, etc., the advent of radio, television and satellite supported communication and telecommunication have radically revolutionized the communication. The vacuum tube provided the core technology for communication channels, in the beginning. Then came the transistor, which offered the base for solid state technology. Of late, integrated circuits (ICs) were the next step, which supplemented the growth of digital technology. The dawn of 21<sup>st</sup> century is witnessing the arrival of super fast, multidimensional and multipurpose digital technology.

Digital technology represents information by the presence or absence of electrical pulses. Digital signals are more robust and digital techniques are well suited to solid state electronics and to computer generated

information. A largely digital network requires a means for delivering high speed digital signals directly to homes and businesses. Yesterday's copper wires and mechanical switching relays were designed to carry only a single type of information, such as, telephone calls, telegrams or telex messages, but today's high capacity optical fiber and sophisticated digital computers can transmit voice, data, or image by converting them into a stream of computer generated digital signals.

In this mode of communication, the signals come in the form of digits of zero (0) or one (1), therefore it is called digital. Zero represents absence of signal and one represents presence of signal. There are no weak or less weak signals - either there will be a perfect signal in the form of digit 1 or there will be no signal in the form of digit 0. This ensures quality transmission and reception of the data in the form of text, audio or video (still or motion). The analogue technology represents information as continuously varying electrical currents, therefore, analogue communication gets interfered by so many factors, such as spark, lightning, etc. Whereas, in digital communication, the digitally transported information/data reaches free from such disturbances perfectly and accurately.

## 2. Observations

The communication media equipped with digital technology can be considered as digital media. Computer aided information systems have become a unique medium of communication. Computers, diskettes, CD-ROMs, multimedia, electronic publications, internet, on-line magazines, e-mail, home pages, bulletin board system (BBS), digital video discs (DVD), etc. are becoming more and more popular among people and the concept of newly emerging digital media is assuming shape as a full-fledged communication media. New advances in the area of computer sciences and fiber optics have made this communication revolution possible, which played a vital role in bringing the world closer. All these advances can be effectively exploited for communication of science and technology, as well. Let us have a look on various possibilities for utilization of the digital media in science communication/popularization.

1. **Multimedia:** The term multimedia has earned a great significance and a new meaning nowadays. Earlier, it was known as combination of different medium of communication, like, print, folk, radio, television, etc., but its new meaning is altogether different. Now multimedia is a computer aided system, which helps provide text, audio and video (both still and motion) outputs on screen. It also offers two way communication. Interactive multimedia packages are also available. If we combine trends in computing and communications, we have the means to store, process and transmit multimedia information, rather than just the text traditionally handled by computer systems. Multimedia, including colour graphics, sound, animation and video has powerful appeal, as an information resource, learning package and communication with entertainment. Users will undoubtedly require access to information in multimedia format, from wherever they happen to be located. The demand for multimedia information by the user will be a significant factor in the future.
2. **CD-ROM:** Compact Disc (CD) is another mode of this beautiful world of digital communication. Thousands of pages can be stored in a small disc. Several books, encyclopaedias, publications are now available on CDs, which can be read on computer screen, either in text form or in multimedia form. This info-packed disc is called CD-ROM (Compact Disc-Read Only Memory). When using this means of modern communication, one can save both - money and space, which were required to buy and store bulky publications.
3. **Internet:** The internet is the network of networks of numerous computers spread all over the world. There is no core computer at the centre as such. The Internet is a composite creature made of lakhs of computer systems scattered across the world. No one knows how many computers are connected with the net. Some 30 years ago, the American Defence Department created the first such computer network as an experiment, with the objective of making military researchers to be in contact with

each other. And today the internet connects millions users worldwide. This on-line facility of fingertip access of desired information has opened new vistas in communication. Internet is also called net or web, in short and also known as world wide web (www), because of its nature of a huge web of networks.

This entire gamut is also known as cyberspace, the term first coined by a science fiction writer William Gibson. Cyberspace is a word derived from the term cybernetics, the science of augmenting living organisms with mechanical or automatic devices to perform specialized or enhanced control functions. Cyberspace is, therefore, an expression that describes humans operating in an electronic universe, where they use computers to communicate and control remote devices by transmitting data/signals via digital links through modems, local area networks (LAN), wide area network (WAN), telephone cables, optical fibbers, communication satellites, etc.

Modem is an electronic device for modulation or demodulation, which is an interface between a computer and the telephone line. A Local Area Network (LAN) is a group of computers and other computer equipments, such as printers and modems, spread over a limited geographical area, which is connected by communication links and network software, to enable any device to interact with any other computer on the network. Internet is known as wide area network. Optical fibbers are hair thin strands, that provide passage to thousands of signals at a time, and thus enhanced bandwidth. Bandwidth is the information carrying capacity of a medium, usually measured in bytes per second. Byte, the binary digit, a unit of data usually represented as 0 or 1. Bytes are different from atoms and follow different rules. These are weightless and are easily and flawlessly reproduced and shipped at nearly the speed of light. Information flows through cyberspace at up to 50 million bytes per second and soon it will flow at rates exceeding 2 billion bytes per second offering speed and accuracy in transportation of desired information/data in the form of text, audio and graphics, etc.

This exciting and highly potential medium has tremendous scope in science communication. Now various sites are available for finding information on different scientific subjects. Different organizations have their home pages on internet, with their specific addresses, like 'http://www.vigyanprasar.com' is the address of Vigyan Prasar's home page on Internet. Hyper Text Transmission Protocol (http) is a command that offers online text transmission. Home page is a place in the site of an organization or an individual on the internet, where various information are available about the organization or individual, such as their profile, products, services, etc. It is also known as web page. Some sites are interactive and one can ask questions and find answers, play games, solve puzzles and interact with persons at remote locations through online chat and e-mail.

Various institutions, which come under a large organization, are connected through intranet, even if they are geographically at remote locations. Intranet offers number of small networks within a broad area network. One can access a computer remotely placed by way giving commands from his computer. Telnet is a command that lets one log into another computer system and interactively use that other computer as though one were sitting in front of it. If you want to retrieve a file from another computer site on the Internet, you can use anonymous FTP, which stands for file transfer protocol.

This is not an appropriate place to go into the details of hardware, but only a glimpse would help in general understanding and common terminology used. As described above, the Internet is connected with numerous systems through various linkages. A Bridge provides transport links between two LAN segments, may be at the same location or at remote location. The 'bridge' also divides a LAN into two or more segments, reducing the overall traffic flow. Routers also interconnect LANs either locally or remotely. They also filter data within a segment or forward them to another segment. Bridges can only forward across a link to a single segment, 'routers' can connect more than two segments together.

Where as Hubs are commonly used in the star topology and act as a focal point for management and control of the network. This is a sensible point, as all traffic passes through the hub, where faults can be detected and information extracted. Hubs can be connected together like building bricks to provide more network ports. Gateways allow work stations on a LAN to access resources provided by a host computer. The host may be at a remote location so that a wide area network link is needed.

4. **Electronic/Online Publications/Journals:** Today we need not to carry heavy printed volumes or books. Several publications, like encyclopaedias, books, journals and magazines are available in the form of computer diskettes, floppies or CD-ROMs, that can be read on the computer. Even various publications are now available on line on the Internet. Various newspapers, journals and science magazines can be accessed on the Internet. Com-Com is India's first on-line popular science magazine simultaneously available on the Internet and Vigyan Prasar's Bulletin Board Service. Many more on-line publications are coming up rapidly. Open access journals are available only through digital media. *Indian Journal of Science Communication* is an open access journal and is available at <[www.iscos.org](http://www.iscos.org)>. Open access of research journals serves a wide range of scholars in developing and developed countries especially who cannot afford to subscribe the expensive journals.
5. **Data Bases:** Various data bases on scientific subjects have been developed and maintained by various organizations world wide. The country is underway for large scale networking through various networks. NCSTC has completed a pioneering pilot project on the development of integrated national data base on science and technology communication software, hardware and human ware, in collaboration with the National Informatics Centre (NIC). This database covers Delhi and Haryana in this phase. It can be extended throughout the country. CSIR has started a Quick Access Information System (QAIS) for providing information on various R&D works of CSIR laboratories to the press. The system is accessible at any laboratory of the organization. That apart, Environment Information System (EnvIS) provides information on environmental subjects, while Agriculture Information System (AgrIS) offers information access on agricultural subjects. Vigyan Prasar's VIPRIS offers information on various subjects of science and technology.
6. **Computer Aided Visual Communication:** The digital media offers enormous possibilities in its uses for educational and communication purposes. Computer generated images can be seen in increasing number in our every day life, i.e. on television as logos, in commercials as dancing fruits and tooth pastes, in fantasy serials as exciting images. Over the years computer programmers have devised an array of Mathematical techniques or algorithms for rendering three dimensional (3 D) images, Computer Aided Designs (CAD), animations and graphics. A computer monitor screen as also a TV is composed of tiny dots that act similar to electric bulbs on a signboard. Each minuscule dot or pixel can be switched on and off like a bulb, much faster dozens of times in a second. With the screen as a canvas and light as paint, a computer creates an image on the glowing surface of a picture tube. One can recall, the very exciting science fiction movie 'Jurassic Park' which attracted a large crowds not only from urban, but also semi urban and rural areas in our country a few years back. The dinosaurs of Jurassic Park were created on computers and their movement was made possible only through the digital technology. Various cartoon shows are being prepared and telecast by way of using computer graphics. The virtual reality has tremendous potential to present the things in a way as if they were present in reality. The virtual reality takes us in an entirely different world, where without going into space, we can feel to be in space or without going into the sea, one can feel as if he were playing on the waves. The computer aided teaching and learning



experiences are proving to be more and more effective and interesting.

7. Text to Speech Modules: This has an added advantage for communication among disabled persons, especially those visually challenged. Multi language text to speech modules are available in various foreign languages. Recently, C-DAC, Pune has developed a multi lingual speech system in different Indian languages. These devices can range from those with a small fixed vocabulary of coded natural speech such as talking toys to broad text to speech system. C-DAC, Pune has also developed the GIST Card, which allows working in various Indian languages on personal computers.
8. Electronic Mail (E-mail)/Online Chat: E-mail has become a favourite means of communication. Each day lakhs of people exchange electronic mail across the globe. Messages are prepared on the sender's computer and are transmitted through telephone lines to the recipient's computer, only by pushing a key on computer keyboard. Every person/organization has specific e-mail identity. For information providers and users, it offers a medium in which distribution costs and transmission time shrink to zero.  
The digital media offers interactive communication channel, in addition to the opportunities for conferencing and online chat. Online chat offers communication between persons of similar interest, sitting even across the continents. By logging in on a particular site, which provides online chat opportunity, one can start chatting with people available on the chat site from different geographic regions at the moment, by way of typing their messages, questions, answers, observations, views, etc., using keyboard and the conversation appears on screen of computer monitor. More than two persons can also participate in chat and thus it becomes conferencing. It has tremendous scope in organizing online scientific discussions. That apart, various other means of digital communication are coming to the fore.

9. Blog Writing, Netlog, Facebook, E-groups, etc.: These are the newest applications of digital media using online services. Blogs are the cyberspaces, where one can contribute his or her ideas, share information or even create own blogs. Most of them are socializing tools on the Internet to share ideas, opinions, visuals, photos, videos, etc. Science and technology can also find its share on these very effective creations. Many e-groups are now available on science communication related areas also. Such as :  
<popularsciencewriters@yahoogroups.com>  
<indiansciencefiction@yahoogroups.com>  
<iswaindia@yahoogroups.com>.
10. Online Courses: Teaching and learning especially in the area of science technology had never been as convenient as it has become now. Thanks to innovative online courses. The National Council for Science & Technology Communication and Indian Science Communication Society have the credit to have been able to start the world's first online course on science journalism, which attracts students from across the world.

### 3. Applications

Now this potential media is available at our doorstep, offering tremendous possibilities for communication of science and technology and it is our turn to get maximum advantage out of it towards taking scientific information and messages to every nook and corner of the country among people. Let us try to find various ways and means to make optimum use of digital media in science communication.

1. Software Development: The digital media provides an ocean of scientific and technological information, packed in CD-ROMs, DVDs, floppies, diskettes and available as never ending current on the internet. One can find a variety of scientific information in the form of text, audio and video. This information can be utilized for development of various kinds of software materials, such as popular science articles, books, posters, etc., on various scientific subjects. Precautions must be taken while using copyright materials, clippings from

video, audio CDs, or graphics and no information should be copied, as it is and must be explained/presented in our own words, style and innovative manner, to avoid infringement of Copyright Act unless expressly allowed by the authors. It is always a good idea and also an act of courtesy to acknowledge the source of the material being used. Such information can be utilized for development of various multimedia presentations on desired scientific subjects. One can find photographs, illustrations, diagrams, etc. available in the digital media. These can be utilized for development of our own software materials, which can be visually enriched by including graphics and visuals. Generally, information on current scientific topics is difficult to find from any other traditional sources, like the discovery of human genome decoding, etc. Such information can be easily accessed from the Internet and an informative and interesting article, based on the latest information, can be prepared overnight and published in newspapers or magazines for its wider reach. Similarly, it can be difficult to find a book on cybernetics but information about cybernetics can be downloaded from the Internet and be utilized for writing a popular article. The visuals obtained from the digital sources can also be utilized for production of video/TV programmes on various scientific subjects. Thus digital media can be a prime source of information for preparation and development of a variety of software materials, which can cater to the requirements of various target audiences. CDs can also be developed on various scientific subjects. Recently, Vigyan Prasar has produced a CD depicting various phases of total solar eclipse and changing climatic/environmental circumstances during this astronomical phenomenon. This must be kept in mind that the information available on the Internet is not necessarily authentic and hence needs to be verified from the primary or authentic source.

2. **Enhancing Indigenous Contents:** It is ironical to observe that there is a great dearth of Indian scientific contents on the internet (although the situation in other mass media is not so pleasant). What is available on the net,

is generally foreign fed information, which may not be suitable to our requirements, but in the absence of our own contents, we are constrained to utilize global information instead of indigenous information. Therefore, there is a crying need to develop materials on indigenous research and development activities and to put them onto the net, so that these can be made available worldwide. Science writers/communicators can play a vital role in enhancing indigenous science and technology information in digital media, as well.

3. **Science and Technology in Indian Languages:** Most of the scientific information is available in English language, especially in digital media. Undoubtedly, if we want to ensure wider reach of scientific information at grass root level, we have to create the desired scientific information in Indian languages and have to make it available through various media to the common people. Of course, digital media may also be one of them. Recently, a few sites have emerged on the internet, which provide information in Indian languages, but there is hardly any information on science and technology. This situation requires immediate correction and new sites are required to be launched, which can provide information about developments in science and technology in Indian languages. Similarly, CD-ROMs, multimedia packages, diskettes, etc. are also needed to be developed, produced and disseminated at mass scale in various Indian languages. Various government, non government, voluntary organizations, business and industrial houses, academic and scientific institutions, media organizations, etc., which are already equipped with information technology, may come forward to venture into this virgin area, by way of offering help and co-operation for the development of new sites and software, especially on indigenous science and technology and in Indian languages.
4. **Various Activities:** Various S&T communication activities/programmes can be organized by using the digital media at various levels. At school level, various

science experiments can be demonstrated to make children aware about the methods of science. Various experiments, such as laws of light and gravity, structure of universe, solar system, etc. Multimedia presentations would make it more interesting and comprehensible. At community level, public demonstrations/ presentations can be organized on subjects of current interest, like cloning, decoding human genome, etc. Questions can be asked from the viewers/ audience and each respondent can also be furnished with additional brief multimedia presentations on the relevant subject, to make the answer more clear. Even ahead of presentations and demonstrations, let us offer people an opportunity to handle/operate various digital media systems, and allow them to develop a feel and understanding about it, only then we should be able to see the gleam of confidence and knowledge in their eyes.

New sites on various scientific subjects on the internet in various Indian languages need to be created. Training programmes for the development of new sites, software materials, such as CDs, multimedia kits, video presentations, animated presentations, simulations, graphics, videos, on indigenous S&T developments, etc., can be organized, in addition to digital media presentations/demonstration on various popular science subjects for various target audiences.

#### **4. Recommendations**

Digital media has got tremendous scope for communication of information and messages on various scientific subjects among various target groups in various formats.

1. **Catering to Various Target Groups:** It can be utilized for varied target groups ranging from children to adults and even to disabled persons. For example, various scientific experiments can be performed on computer screen. One can perform a dissection of a frog without actually dissecting it. Similarly, titration can be performed on screen without using chemicals. Various phases of eclipse and climatic changes during eclipse can be simulated, which can be seen on screen and one can feel and appreciate the real situation of an eclipse. More and more interactive sites are required to be created to allow more and more people to join online conversation/ communication/ discussion on various scientific subjects and issues. Computer quizzes, puzzles, games, etc., on scientific topics could be an attraction for the children for learning while playing. Various programmes, software materials, CDs, etc., can be developed using interesting formats for creating interest and excitement about science among children.
2. **Using Various Formats:** Like any other medium, it is necessary to present scientific information in a simple and interesting manner for which a science communicator has to choose appropriate format and style that suits to the desired target audience. In digital media too, one must be careful to choose an appropriate format for presenting scientific information. Various interesting formats can be selected, such as popular science articles, interviews with scientists/technologists, questions and answers, quizzes, puzzles, science fictions, stories, animation, simulation, cartoons, comics, news, letters, how things work, do-it-yourself activities, reports of seminars, symposia, conferences, reviews of scientific books and other software materials and programmes, discussions on various scientific issues, such as socio-legal issues emerged due to news about genetic manipulation in human beings, etc. If the information is presented in an appropriate format as per the requirement of the desired target audience, it can be effectively communicated and assimilated.
3. **Covering Various Subjects:** Now several CDs and multimedia packages are available on various scientific subjects. However, more software materials are required to be developed on various scientific subjects, such as general science, environment, agriculture, medical science and educational subjects, etc. CDs can be prepared on various scientific subjects, such as, agricultural practices, diseases with their symptoms and remedies, etc. to display

modern scientific farming methods to the farmers. Although various agencies are already in the job, but more concerted, need-based and pin-pointed efforts are necessary. Various CD-ROM series will allow fast and efficient data retrieval through convenient easy-to-use search strategies in-built in the CD-ROM and will also allow full text searching, display of text, illustrations, etc., especially on indigenous S&T developments.

## 5. Prospects and constraints

Undoubtedly, digital media has opened the floodgates of information available worldwide. But, the other side of the coin cannot be ignored. Prof. Yash Pal, a well known scientist and science communicator has cautioned about the so called rat race towards information technology and digital technology. According to him, it is not going to create knowledge creators, but definitely, it will create knowledge workers, who will handle knowledge. He said that Albert Einstein and Bill Gates could not be placed in the same category. He also warned that it is unfair to give computers to the children below 5 years as it not only affects their binocular vision but also overall mental development. He was speaking on the occasion of a National Seminar on "The Challenges in Public Appreciation of Science in Digital Age", organized by the Indian Science Writers' Association at Indian National Science Academy, New Delhi, during June 16-17, 2000, with a view to address and discuss the problems and issues emerging due to the advent of new digital technology and changing scenario of people's perspective about science and technology. Dr. R. A. Mashelkar, Director General, CSIR, has emphasized the need of Indian contents on the internet, while delivering the key note address at the above seminar. He underlined the need for the authors in Indian languages, who can eventually contribute to enhance Indian science contents on the Internet.

Another threat of digital media is that despite number of checks, protections and passwords, etc., there are incidents of manipulation of the original data by unauthorized or unidentified persons from across the territories or continents. During the Indian Science Congress held at Pune in January 2000, the site of Indian Science Congress on the Internet was entirely disturbed

by the foreign based hackers, by way of putting wasteful data into the site and replacing the information on Indian Science Congress. The data available on digital media can be easily corrupted or wiped out by mishandling or by manifestation of computer viruses. Therefore, it needs to be preserved properly.

While providing unmatched opportunities and possibilities, the digital media has some limiting factors. We have seen through the evolution of communication and technology that every change has brought certain implications along with its brighter side. Comic's revolution brought a boom in enhanced reading habits, especially among children. Then came television that restricted children from going outside, playing in the playgrounds and interacting with friends. Children started watching films and cartoons and adventure shows, etc. on TV as much as possible. Of course it enhanced their knowledge base, understanding and power of imagination, but it also left its ill effects. Now the Internet and computer games, etc. have made great impact on them and they are becoming more and more friendly to computers other than family members and friends. A considerable decline in the reading habits of the people can be noticed due to the advent of digital media. The decline in reading habits also leads to decline in other mass media. Since various newspapers, magazines, journals are also available on the net, one can prefer to read today's news on the net instead of going through a broad size newspaper. Of course digital media has a great role to play in communication but it cannot overpass other mass media due to its limited reach and availability.

## 6. Conclusions

The study has revealed that science contents have a share of 2.12% in digital media as compared to that of 3.4% in print media. Some 2.02% audience preferred online science contents. It emerged that the demand and supply of online science contents in the country are almost similar.

The Government of India has already given impetus to information technology to ensure its wider reach all over the country. A national high speed inter university data network 'Sankhya Vahini' has been envisaged to connect 10 metropolitan cities and 100 universities/institutions of higher learning.

The advancement of digital technology has reached to the level of increased processor power and storage capacity where multimedia is easily handled by personal computers. The ability to handle multimedia information, including colour graphic images, sound and video, makes computers much more interesting. This, coupled with a gradually reduced price, leads to take high powered systems into more offices and homes. Hand held personal digital assistants (PDAs) are already in the market and would go more widely if problems with handwriting recognition and wireless communication were overcome and prices were to fall. Although prices for computers and connection to the Internet are by no means within the reach of every household but increasingly more people are buying home PCs and getting internet connections. Since more people have access to computers, it is obvious to say that more people use digital media resources to quench their thirst for knowledge and to get acquainted with the latest advancements.

Existing telephone cables can even be used to deliver services, such as video on demand without the need to install either optical fiber cable or an integrated services digital network (ISDN) link. As satellite and terrestrial broadcasting services are moving to digital transmission, we can foresee a convergence of computing equipment with television and telephony, so that one item of equipment will provide access to all forms of digital information. Furthermore, portable telephones have not only dropped in price, but are also increasingly digital. The move to digital mobile telephones allows users to connect them directly to portable computers to exchange multimedia data.

Digital media is lowering down the requirement of literacy, as even a less qualified person can operate and explore information from the digital media, may be in audio-visual form. Science communication should see a tremendous boost in digital media. Public demonstrations on scientific subjects can be made more effective interesting and comprehensible by the use of multimedia. Fundamentals of science can be easily explained by using this media. Video phone and video conferencing offer a unique opportunity to interact while sitting across continents. Direct to home (DTH) transmission offers an opportunity for taking information through cable networks to the television sets in digital form. Pager is a device through which

messages can be digitally conveyed through radio frequencies. News about weather and climate, etc. are already available through various paging services. Science news can also be introduced on pager. The laptop computers fitted with CD drives, left desktop computers behind and made possible to carry them in a briefcase. This facilitated working and communicating in extra time, while on way to&from work or during odd hours. Palmtop model is also about to come, that will give further boost to communication, as internet access would also be possible through it.

Science communication can also see possibilities in e-commerce or e-business. New business opportunities can be explored in development of software materials and creation of new sites as well as transformation and production of software materials from one language to another. Various e-commerce sites can be created for giving information about availability of various kinds of software materials on science, resource persons, experts, writers, science communication services, etc. Advertisements can also be placed on various software materials and on S&T sites on internet in the form of strips of scientific messages, products and services, etc. Digital signature and digital money can make e-commerce in the area of science communication possible.

We are experiencing a worldwide digital brotherhood through the digital media and people are even interacting with the others whom they have never met earlier. Cyber Cafés and Kiosks are not only providing the facilities of internet surfing, e-mail, multimedia and other info-exchange services to the common people, but also self employment. Cyber education is yet another area of importance, which can bring scientific knowledge to the people in an informal manner. If Internet reaches up to district level and extends to rural areas, as the reports are appearing in the media, the country would see a remarkable growth in overall development, why not in science communication.

Thus, the stage is all set for taking most of the advantages of the infinite potential and opportunities, that digital media offer for popularization of science. The NCSTC is looking forward to venture into this emerging area of science communication and planning to develop a detailed programme to better serve the people

by making optimum use of digital media in popularization of science.

## 7. References

- [1] Patariya, Manoj, Science Communication through Digital Media, NCSTC Communications, August 2000.
  - [2] ibid (ed.), Communicating Science : Highlights 2008-2009, National Council for Science & Technology Communication, New Delhi, 2009.
  - [3] Hofsetter Fred T., Multimedia Literacy, McGraw-Hill, New Delhi, 2001.
  - [4] Bhattacharya, Parth, et al, Intellectual Property Rights Information through Digital Medium : A Case Study, *Indian Journal of Science Communication*, January-June, 2003.
  - [5] Traditional Knowledge Digital Library (TKDL), National Institute of Science Communication and Information Resources, CSIR, New Delhi.
- 
- 

## Learning Science in Informal Environments

Bruce B. Lewenstein  
Cornell University 321 Kennedy Hall  
Ithaca, NY 14853 USA  
b.lewenstein@cornell.edu

**Abstract.** Informal science is a burgeoning field that operates across a broad range of venues and envisages learning outcomes for individuals, schools, families, and society. The evidence base that describes informal science, its promise, and effects is informed by a range of disciplines and perspectives, including field-based research, visitor studies, and psychological and anthropological studies of learning. This paper summarizes a new report prepared by the U.S. National Research Council on Learning Science in Informal Environments. The report draws together disparate literatures, synthesizes the state of knowledge, and articulates a common framework for the next generation of practice in and research on learning science in informal environments across a life span. The report is the product of a 3-year study by the U.S. National Research Council's Committee on Learning Science in Informal Environments. Contributors include recognized experts in a range of disciplines--research and evaluation, exhibit designers, program developers, and educators. They also have experience in a range of settings--museums, after-school programs, science and technology centers, media enterprises, aquariums, zoos, state parks, and botanical gardens. More information, including the ability to read the entire report online, is at [http://www.nap.edu/catalog.php?record\\_id=12190](http://www.nap.edu/catalog.php?record_id=12190). Also at that website, one may download for free a 20-page executive summary of the report.

**Keywords:** informal science education, learning science, science museums, public communication of science and technology.

### 1. Introduction

This paper is drawn from the executive summary of the 2009 U.S. National Research Council report titled *Learning Science in Informal Environments: People, Places, and Pursuits*, edited by Philip Bell, Bruce V.

Lewenstein, Andrew Shouse, and Michael Feder, published in Washington, DC, by the National Academies Press. The report is more than 350 pages long, and includes more than 1200 citations.

## 2. Executive Summary

Science is shaping people's lives in fundamental ways. Individuals, groups, and nations increasingly seek to bolster scientific capacity in the hope of promoting social, material, and personal well-being. Efforts to enhance scientific capacity typically target schools and focus on such strategies as improving science curriculum and teacher training and strengthening the science pipeline. What is often overlooked or underestimated is the potential for science learning in nonschool settings, where people actually spend the majority of their time.

Beyond the schoolhouse door, opportunities for science learning abound. Each year, tens of millions of Americans, young and old, explore and learn about science by visiting informal learning institutions, participating in programs, and using media to pursue their interests. Thousands of organizations dedicate themselves to developing, documenting, and improving science learning in informal environments for learners of *all* ages and backgrounds. They include informal learning and community-based organizations, libraries, schools, think tanks, institutions of higher education, government agencies, private companies, and philanthropic foundations. Informal environments include a broad array of settings, such as family discussions at home, visits to museums, nature centers or other designed settings, and everyday activities like gardening, as well as recreational activities like hiking and fishing, and participation in clubs. Virtually all people of all ages and backgrounds engage in activities that can support science learning in the course of daily life.

The Committee on Science Learning in Informal Environments was established to examine the potential of nonschool settings for science learning. The committee, comprised of 14 experts in science, education, psychology, media, and informal education, conducted a broad review of the literatures that inform learning science in informal environments. Our

charge specifically included assessing the evidence of science learning across settings, learner age groups, and over varied spans of time; identifying the qualities of learning experiences that are special to informal environments and those that are shared (e.g., with schools); and developing an agenda for research and development.

The committee organized its analysis by looking at the places where science learning occurs as well as cross-cutting features of informal learning environments. The "places" include *everyday experiences*—like hunting, walking in the park, watching a sunrise—*designed settings*—such as visiting a science center, zoo, aquarium, botanical garden, planetarium—and *programs*—such as after-school science, or environmental monitoring through a local organization. Cross-cutting features that shape informal environments include *the role of media* as a context and tool for learning and the opportunities these environments provide for *inclusion of culturally, socially, and linguistically diverse communities*.

We summarize key aspects of the committee's conclusions here, beginning with evidence that informal environments can promote science learning. We then describe appropriate learning goals for these settings and how to broaden participation in science learning. Finally, we present the committee's recommendations for practice.

## 3. Promoting Learning

Do people learn science in nonschool settings? This is a critical question for policy makers, practitioners, and researchers alike—and the answer is yes. The committee found abundant evidence that across all venues—everyday experiences, designed settings, and programs—individuals of all ages learn science. The committee concludes that:

- Everyday experiences can support science learning for virtually all people. Informal learning practices of all cultures can be conducive to learning systematic and reliable knowledge about the natural world. Across the life span, from infancy to late adulthood, individuals learn about the natural world and develop important skills for science learning.
- Designed spaces—including museums, science centers, zoos, aquariums, and

environmental centers—can also support science learning. Rich with real-world phenomena, these are places where people can pursue and develop science interests, engage in science inquiry, and reflect on their experiences through sense-making conversations.

- Programs for science learning take place in schools and community-based and science-rich organizations and include sustained, self-organized activities of science enthusiasts. There is mounting evidence that structured, nonschool science programs can feed or stimulate the science-specific interests of adults and children, may positively influence academic achievement for students, and may expand participants' sense of future science career options.
- Science media, in the form of radio, television, the Internet, and handheld devices, are pervasive and make science information increasingly available to people across venues for science learning. Science media are qualitatively shaping people's relationship with science and are new means of supporting science learning. Although the evidence is strong for the impact of educational television on science learning, substantially less evidence exists on the impact of other media—digital media, gaming, radio—on science learning.

#### 4. Defining Appropriate Outcomes

To understand whether, how, or when learning occurs, good outcome measures are necessary, yet efforts to define outcomes for science learning in informal settings have often been controversial. At times, researchers and practitioners have adopted the same tools and measures of achievement used in school settings. In some instances, public and private funding for informal education has even required such academic achievement measures. Yet traditional academic achievement outcomes are limited. Although they may facilitate coordination between informal environments and schools, they fail to reflect the defining characteristics of informal environments in three ways. Many academic achievement outcomes (1) do not encompass the range of capabilities that informal settings can promote; (2) violate critical assumptions about these settings, such as their

focus on leisure-based or voluntary experiences and nonstandardized curriculum; and (3) are not designed for the breadth of participants, many of whom are not K-12 students.

The challenge of developing clear and reasonable goals for learning science in informal environments is compounded by the real or perceived encroachment of a school agenda on such settings. This has led some to eschew formalized outcomes altogether and to embrace learner-defined outcomes instead. The committee's view is that it is unproductive to blindly adopt either purely academic goals or purely subjective learning goals. Instead, the committee prefers a third course that combines a variety of specialized science learning goals used in research and practice.

#### 5. Strands of Science Learning

We propose a “strands of science learning” framework that articulates science-specific capabilities supported by informal environments. It builds on the framework developed for K-8 science learning in *Taking Science to School* [1]. That 4-strand framework aligns tightly with our Strands 2 through 5. We have added two additional strands—Strands 1 and 6—which are of special value in informal learning environments. The six strands illustrate how schools and formal environments can pursue complementary goals and serve as a conceptual tool for organizing and assessing science learning. The six interrelated aspects of science learning covered by the strands reflect the field's commitment to participation—in fact, they describe what participants do cognitively, socially, developmentally, and emotionally in these settings.

Learners in informal environments:

- **Strand 1:** Experience excitement, interest, and motivation to learn about phenomena in the natural and physical world.
- **Strand 2:** Come to generate, understand, remember, and use concepts, explanations, arguments, models and facts related to science.
- **Strand 3:** Manipulate, test, explore, predict, question, observe, and make sense of the natural and physical world.
- **Strand 4:** Reflect on science as a way of knowing; on processes, concepts, and



institutions of science; and on their own process of learning about phenomena.

- **Strand 5:** Participate in scientific activities and learning practices with others, using scientific language and tools.
- **Strand 6:** Think about themselves as science learners and develop an identity as someone who knows about, uses, and sometimes contributes to science.

The strands are distinct from, but overlap with, the science-specific knowledge, skills, attitudes, and dispositions that are ideally developed in schools. Two strands, 1 and 6, are particularly relevant to informal learning environments. Strand 1 focuses on generating excitement, interest, and motivation—a foundation for other forms of science learning. Strand 1, while important for learning in any setting, is particularly relevant to informal learning environments, which are rich with everyday science phenomena and organized to tap prior experience and interest. Strand 6 addresses how learners view themselves with respect to science. This strand speaks to the process by which individuals become comfortable with, knowledgeable about, or interested in science. Informal learning environments can play a special role in stimulating and building on initial interest, supporting science learning identities over time as learners navigate informal environments and science in school.

The strands serve as an important resource on which to develop tools for practice and research. They should play a central role in refining assessments for evaluating science learning in informal environments.

## 6. Broadening Participation

There is a clear and strong commitment among researchers and practitioners to broadening participation in science learning. Efforts to improve inclusion of individuals from diverse groups are under way at all levels and include educators and designers, as well as learners themselves. However, it is also clear that laudable efforts for inclusion often fall short. Research has turned up several valuable insights into how to organize and compel broad, inclusive participation in science learning. The committee concludes:

Informal settings provide space for all learners to engage with ideas, bringing their prior knowledge and experience to bear.

Learners thrive in environments that acknowledge their needs and experiences, which vary across the life span. Increased memory capacity, reasoning, and metacognitive skills, which come with maturation, enable adult learners to explore science in new ways. Senior citizens retain many of these capabilities. Despite certain declines in sensory capabilities, such as hearing and vision, the cognitive capacity to reason, recall, and interpret events remains intact for most older adults.

Learning experiences should reflect a view of science as influenced by individual experience as well as social and historical contexts. They should highlight forms of participation in science that are also familiar to nonscientist learners—question asking, various modes of communication, drawing analogies, etc.

Adult caregivers, peers, teachers, facilitators, and mentors play a critical role in supporting science learning. The means they use to do this range from simple, discrete acts of assistance to long-term, sustained relationships, collaborations, and apprenticeships.

Partnerships between science-rich institutions and local communities show great promise for structuring inclusive science learning across settings, especially when partnerships are rooted in ongoing input from community partners that inform the entire process, beginning with setting goals.

Programs, especially during out-of-school time, afford a special opportunity to expand science learning experiences for millions of children. These programs, many of which are based in schools, are increasingly folding in disciplinary and subject matter content, but by means of informal education.

## 7. Recommendations

The committee makes specific recommendations about how to organize, design, and support science learning. These recommendations provide a research and development agenda to be explored, tested, and refined. They have broad reach and application for a range of actors, including funders and leaders in practice and research; institution-based staff who are responsible for the design,

evaluation, and enactment of practice; and those who provide direct service to learners—scout leaders, club organizers, front-line staff in science centers. Here we make recommendations to specific actors who can influence science learning in practice. Additional recommendations for research appear in Chapter 9 [included in this version of the executive summary].

## 7.1 Exhibit and Program Designers

Exhibit and program designers play an important role in determining what aspects of science are reflected in learning experiences, how learners engage with science and with one another, and the type and quality of educational materials that learners use.

**Recommendation 1:** Exhibit and program designers should create informal environments for science learning according to the following principles. Informal environments should:

- Be designed with specific learning goals in mind (e.g., the strands of science learning).
- Be interactive.
- Provide multiple ways for learners to engage with concepts, practices, and phenomena within a particular setting.
- Facilitate science learning across multiple settings.
- Prompt and support participants to interpret their learning experiences in light of relevant prior knowledge, experiences, and interests.
- Support and encourage learners to extend their learning over time.

**Recommendation 2:** From their inception, informal environments for science learning should be developed through community-educator partnerships and whenever possible should be rooted in scientific problems and ideas that are consequential for community members.

**Recommendation 3:** Educational tools and materials should be developed through iterative processes involving learners, educators, designers, and experts in science, including the sciences of human learning and development.

## 7.2 Front-Line Educators

Front-line educators include the professional and volunteer staff of institutions and programs that offer and support science learning experiences. In some ways, even parents and

other care providers who interact with learners in these settings are front-line educators. Front-line educators may model desirable science learning behaviors, helping learners develop and expand scientific explanations and practice and in turn shaping how learners interact with science, with one another, and with educational materials. They may also serve as the interface between informal institutions and programs and schools, communities, and groups of professional educators. Given the diversity of community members who do (or could) participate in informal environments, front-line educators should embrace diversity and work thoughtfully with diverse groups.

**Recommendation 4:** Front-line staff should actively integrate questions, everyday language, ideas, concerns, worldviews, and histories, both their own and those of diverse learners. To do so they will need support opportunities to develop cultural competence, and to learn with and about the groups they want to serve.

## 7.3 Researchers and Evaluators

Improving the quality of evidence on learning science in informal environments is a paramount challenge. Research and evaluation efforts rely on partnerships among curators, designers, administrators, evaluators, researchers, educators, and other stakeholders whose varied interests, expertise, and resources support and sustain inquiry. Accordingly our recommendations address investigators and the broader community that collaborates with investigators and consumes research and evaluation results.

**Recommendation 5:** Researchers, evaluators, and other leaders in informal education should broaden opportunities for publication of peer-reviewed research and evaluation, and provide incentives for investigators in nonacademic positions to publish their work in these outlets.

**Recommendation 6:** Researchers and evaluators should integrate bodies of research on learning science in informal environments by developing theory that spans venues and links cognitive, affective, and sociocultural accounts of learning.

**Recommendation 7:** Researchers and evaluators should use assessment methods that do not violate participants' expectations about learning in informal settings. Methods should

address the science strands, provide valid evidence across topics and venues, and be designed in ways that allow educators and learners alike to reflect on the learning taking place in these environments.

## 8. Areas for Future Research

Informal environments can be powerful environments for learning. They can be organized to allow people to create and follow their own learning agenda and can provide opportunities for rich social interactions. While this potential is often only partially fulfilled, research has illustrated that experience in informal environments can lead to gains in scientific knowledge or increased interest in science. However, further exploration is needed to provide a more detailed understanding of not only what is learned, but also of how the distinct features of informal environments contribute to their broad and long-term impact on learners. In the report, the committee outlines below the areas in which further research is particularly needed.

- Tools and Practices That Contribute to Learning
- Learning Strands
- Cumulative Effects of Informal Science Learning
- Supporting Learning for Diverse Groups
- Media and their Effects

## Acknowledgements

This paper reproduces, with small changes, the executive summary of the full report. I thank my colleagues on the committee for their hard work and contributions to this document.

## Reference

- [1] National Research Council. (2007). *Taking science to school: Learning and teaching science in grades K-8*. Committee on Science Learning, Kindergarten Through Eighth Grade. R.A. Duschl, H.A. Schweingruber, and A.W. Shouse (Editors.). Washington, DC: The National Academies Press.
- 
- 

## New Ways to Learn Science with Enjoyment – Robotics as a Challenge

A.F. Ribeiro

Univ. of Minho, Dep. Industrial Electronics,  
Campus de Azurém, 4800-058 Guimarães,  
PORTUGAL  
fernando@dei.uminho.pt

**Abstract.** It is well known that during their learning process youngsters prefer and enjoy exciting challenges, so that they don't get bored in school. Many of those challenges are blossoming all around the world in an annual basis, and they stimulate students because they create new objectives, they allow creativity, discovering new and unique solutions and allow comparison of the work carried out by other teams.

The robotics interest has been growing quickly and many schools are adopting this knowledge area due to its multidisciplinary, for being stimulating, for allowing students creativity, for being so practical and hands-on, and it technologically sounds good.

Many challenges have been created in the last few years, both pedagogical and competitive, and requiring different levels of know-how.

This paper describes the most important robotics challenges in terms of its main objectives and rules, the age target, its geographical localization, its average budget and the first steps to be taken for new teams. After reading this paper teachers will be able to decide which robotic challenge is more suitable for his team.

**Keywords:** mobile and autonomous robotics, events, learning experience, science, youngster, hands-on.

## 1. Introduction

To bring up successful Engineers for the future, the teaching of science to youngsters is extremely important. Multidisciplinary and hands-on projects at early stages can enrich their skills and allow them to feel and experience the difficulties of a real challenge.

The development of Robotics is a good example of such projects. Amongst others, the main advantages for the students consist of acquiring knowledge in various areas such as

electronics, programming, communications, mechanics, etc., the experience of working in group, the development of real physical prototypes built by themselves, and also the possibility of participating in robotics competitions with other teams and getting the possibility of comparing their work and discussing it with other people. Above all, this is easily become in the end, a rewarding learning experience.

Many new teams are emerging and many others are willing to start this new challenge but sometimes they can find difficulties to start and to get information regarding robotics.

This paper tries to elucidate about the first steps and the first competitions to participate on. It does not describe all the robotics events worldwide due to lack of space but the ones that are most relevant.

## 2. Motivation

Many excuses are heard from some teachers NOT to start such challenge.

This is not my field of knowledge – that is not an excuse because anyone can read and learn about the field, there are many introductory books, the level of understanding to build a junior robot is not very high, and above all it is possible to ask help to another teacher to get involved.

There is no budget for such a project – That is also not an excuse because most components are cheap and some others you can find at home. Even recycling is an option, since used motors and sensors from old devices can be used in such robots.

I will not be a team member because this is for youngster and I am too old – The experience of an adult is always important to guide youngsters. Also, teachers must accept that they learn much with the students during these projects. Students are normally very creative and they integrate ideas from other projects building up unpredictable but working solutions, from which everyone can benefit.

Sometimes, it is the students who come up with the idea of building a robot and the teacher should not avoid their project. The teachers should help and support them. A motivated team is a group of people which will not create problems to the teacher and they become much friendly than before.

It is also important to point out that participating in competitions dignifies not just the team but above all the school which they belong too. When a team has the robot built, they can participate in competitions and the name of the school will be used.

## 3. Where to start

There are many robotics kits which you can buy off the shelf and build by yourself [1] [2] [3] [4] [5] [6] [7] [8]. They come with a building manual and in the end you get a fully working robot, but just that. But, if you want to participate in competitions, you must bear in mind that each one has its own rules, regarding dimensions, autonomy, tasks to perform, type of sensors, etc. Therefore, you should first decide in which competitions you would like to participate and only then you decide the robot to build. Following, there is a brief description of the most important events on which you can participate.

### 3.1 First LEGO League (FLL)

The FIRST Lego League (FLL) is an international competition for young students (ages 9-16), organized annually by FIRST [9]. There are so many participants that, there they had to separate on local, regional and national competitions before the final which normally is held around April or May.

The contest focus a different science related topic, and the themes used so far were:

- 1999 - Mission of astronauts in a space station
- 2000 - A volcano eruption
- 2001 - The Arctic Impact
- 2002 - City sites related tasks
- 2003 - Mars rover mission
- 2004 - Problems related with disabled people
- 2005 - Ocean odyssey Marine tasks
- 2006 – Nanotechnology
- 2007 - Alternative energy
- 2008 - Climate of planet earth
- 2009 – Transportation
- 2010 – Biomedicine (still to come)

The scenario is completely built out of LEGO bricks and each team has to design a robot (also made of LEGO bricks only) to fulfil the required tasks, build the robot and program it. There are several tasks but these are normally very simple.



Figure 1. FLL Scenario (2004)

This is a LEGO based event, where participants need to buy a special robot based LEGO kit (one or more, depending on the desired degree of complexity).

There are two types on sale: LEGO MindStorms with RCX controller (first version) and a more recent version with the NXT controller [10]. The prices may vary depending on the countries but it will cost around about 200-300 Euros (each box). The box comes with hundreds of LEGO parts, manuals to build many robots, software to program them, proper cables to link the construction to your computer, etc.

The LEGO parts are standard and it is well known that everyone can build LEGOS, which makes the mechanical build up very easy. Then, the programming part is also very accessible because the software environment has a nice graphical user interface which works with objects that are very easy to program. The programming instructions are so simple that the box targets 11 years old kids.

More information about this league available on <http://www.firstlegoleague.org/>



Figure 2. FLL LEGO robot - RCX controller 3.2 Eurobot

The Eurobot [11] competition was first held in 1998, and started as a national competition in France but soon became an international amateur

robotics contest open to teams of young people (school projects or private clubs). Participate on Eurobot students from secondary school up to university level. Mostly held in France this event was also organized in Switzerland, Italy, Germany, etc. The number of participating teams is over 200 (in France) and then the best three teams of each country get together in the final.

The main objective consists of building and programming a mobile robot to perform a certain task, different every year. The missions so far have been:

- 1998 - Football
- 1999 - Castles Attack
- 2000 - Fun Fair
- 2001 - Space Odyssey
- 2002 - Flying Billiards
- 2003 - Heads or Tails
- 2004 - Coconut Rugby
- 2005 - Bowling
- 2006 - Funny Golf
- 2007 - Robot Recycling Rally
- 2008 - Mission to Mars
- 2009 – Temple of Atlantis
- 2010 – Feed the World (still to come)

In this event, always compete two teams on the board, trying to eliminate each other. The winner continues on the competition and passes to the next round.

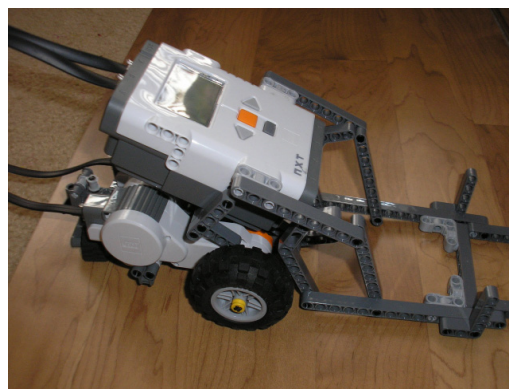


Figure 3. FLL LEGO robot - NXT controller

The budget to build a robot to participate on this challenge can be something between 3 or 4 hundred Euros, up to a couple of thousands, but one should bear in mind that it is highest budget that wins, but the team with more creativity.

The know-how required to build such a robot is relatively high.

Apart from the robotic competition, this is an amazing event gathering fun, high technology,

friendship, creativity, education and passion. The environment is very friendly, with lots of activities for youngsters, parties, etc., and youngsters just love it.

More information about this league is available on <http://www.eurobot.org>.



Figure 4. Eurobot official table

### 3.2 Eurobot

The Eurobot [11] competition was first held in 1998, and started as a national competition in France but soon became an international amateur robotics contest open to teams of young people (school projects or private clubs). Participate on Eurobot students from secondary school up to university level. Mostly held in France this event was also organized in Switzerland, Italy, Germany, etc. The number of participating teams is over 200 (in France) and then the best three teams of each country get together in the final. The main objective consists of building and programming a mobile robot to perform a certain task, different every year. The missions so far have been:

- 1998 - Football
- 1999 - Castles Attack
- 2000 - Fun Fair
- 2001 - Space Odyssey
- 2002 - Flying Billiards
- 2003 - Heads or Tails
- 2004 - Coconut Rugby
- 2005 - Bowling
- 2006 - Funny Golf
- 2007 - Robot Recycling Rally
- 2008 - Mission to Mars
- 2009 – Temple of Atlantis

**2010 – Feed the World (still to come)**

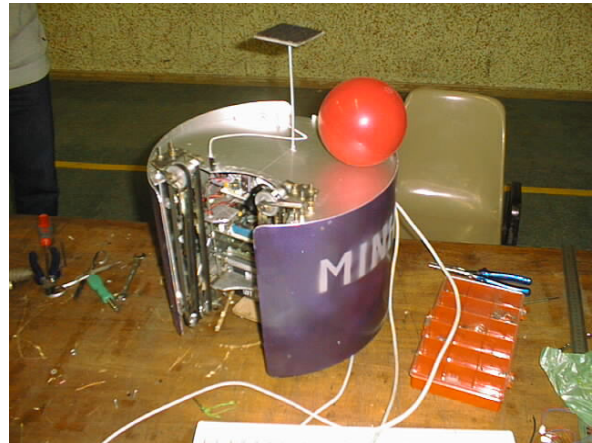


Figure 5. Minho team Robot on Eurobot

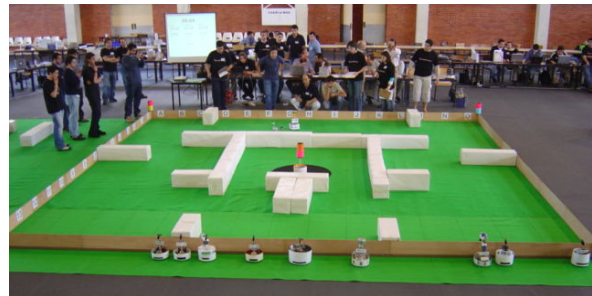


Figure 6. Competition Maze

### 3.3 Micro-Rato (Micro-Mouse)

This robotics competition is a Portuguese event organized by the University of Aveiro and started in 1995 with his students [12]. It is a one day event held annually in May and consists of a 5m by 5m maze where the robots have to find the way out in the shortest time, guided by infrared sensors. The challenge is the same every year although a few minor changes are implemented. Participate university students and in the last few years some secondary schools dared to participate and they are having good results. The complexity of this challenge is between the First LEGO League and the Eurobot. The number of participating teams rounds about 20. First a technical inspection is made on the robots, and then the teams participate on rounds. The best times go forward until the final. On each round 3 robots participate at the same time, so that they have to avoid collisions with each other.

Rules are available on <http://microrato.ua.pt/> (unfortunately, only on Portuguese). There is no

standard robotic kit, and this challenge is more suitable for electronics students. The budget to build this type of robot can vary between 100 and 400 Euros.

### 3.4 RoboCup

Originally called as Robot World Cup Initiative, consists of an international research and education initiative [13]. The idea is to foster Artificial Intelligence and intelligent robotics research by providing a standard problem where wide range of technologies can be integrated and examined. The football was the main challenge. The idea is to build a team of autonomous robots able to play and win against a human team, by the year 2050. Soon other challenges appear, like the rescue league, the RoboCup@home league, and leagues for juniors.

This scientific challenge started in 1997 in Nagoya (Japan) and since then has been organized annually all around the world, being the next edition in 2010 in Singapore. The last edition received around about 200 participants from 35 countries. Due to the high number of teams willing to participate, each country has a national competition where the best teams are chosen. In Portugal, Robotica [14] is the official tournament and it is held annually in a different location. It started in 2001 in Guimarães and the next edition is in 2010 in Leiria/Batalha.

There are three junior leagues [15] and these are describe next: Football, Rescue and Dance. On each of these leagues there are two age groups: Primary goes up to 14 years old, and Secondary from 14 to 18 years old.

The level of complexity of these robots can vary very much. Most teams can compete there.



Figure 7. Two robots built for Micro-Rato

#### 3.4.1 Football or Soccer Junior

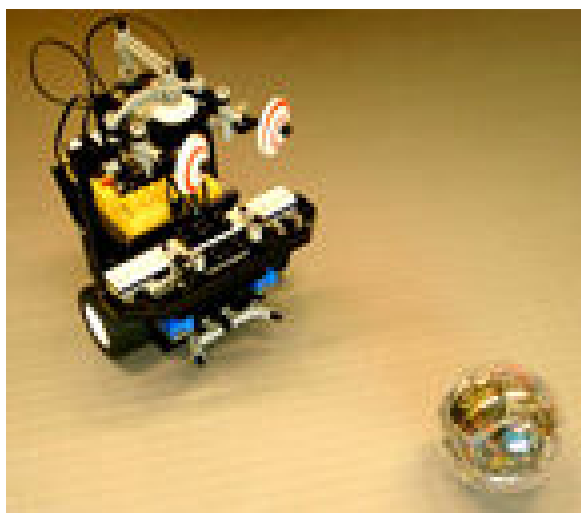


Figure 8. Football junior robot (Primary)

Each team has to build two robots able to play football in a green field (carpet). The ball used transmits infra-red signals in many directions so the robot can recognise it. The goals are coloured one in yellow and the other in blue. There is a human referee. The robots can be built using the LEGOS or built by the team members using traditional electronic components. Rules available on <http://www.robocupjunior.org>

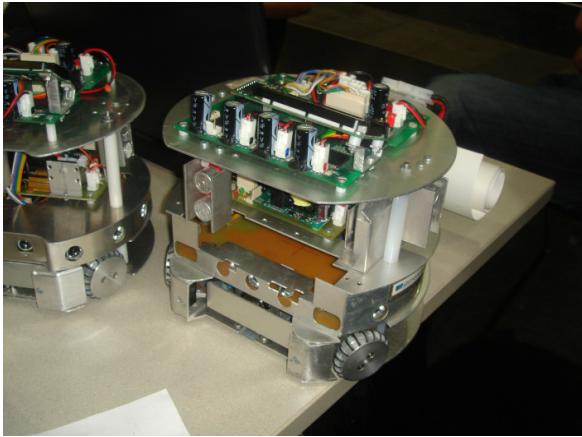


Figure 9. Football junior robot (Secondary)

### 3.4.2 Rescue Junior

On the Rescue league, the teams have to build one robot able to move in a two levels scenario which contains a black line on a white background, with some victims on the line (figures of man laying down) in two colours (green and gray).

The robots have to follow the black line, count the number of victims, signal it with LEDs, and move to the upper floor (going up a ramp). For each successful task the team receives points and for failed tasks the team is deducted points. There is also a jury to mark the points of the game.

The rules for this league can be seen on <http://www.robocupjunior.org>

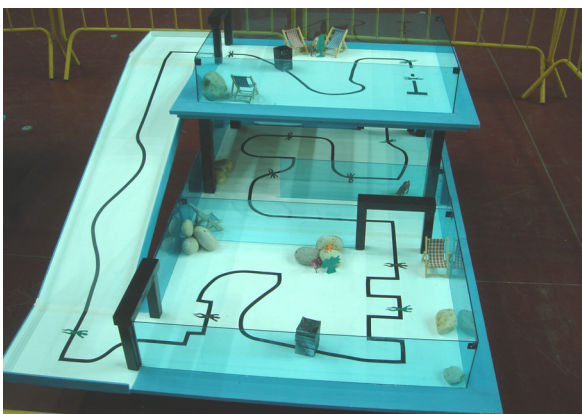


Figure 10. Rescue junior scenario

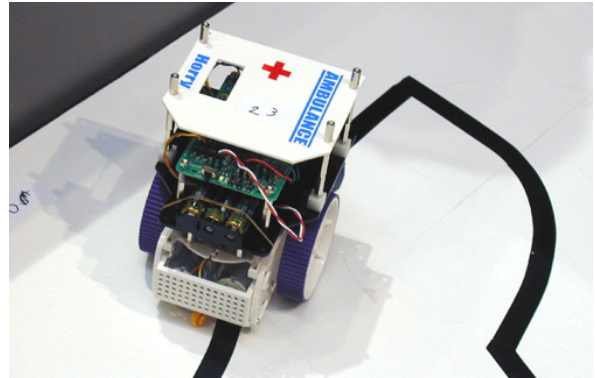


Figure 11. Rescue junior robot (Primary)

### 3.4.3 Dance Junior



Figure 12. Rescue junior robot (Secondary)

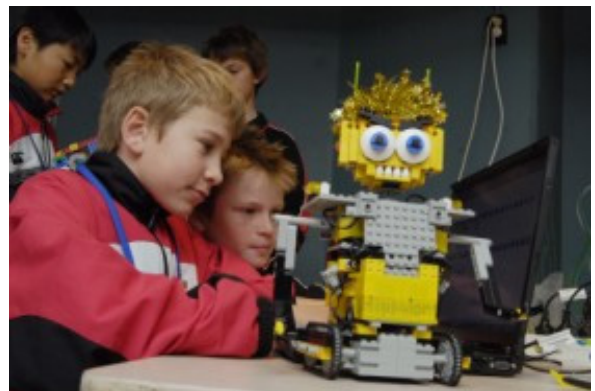


Figure 13. Dance junior robot (Primary)



This league gives students more creativity freedom. The main objective is to have robots performing in a stage with music. They are responsible for the robots build up, the choice of music and its choreography, as well as the robots dressing. The human team mates can also perform at the same time as the robots, during the two minutes total time. Some teams make robots dance, some others create bands, where the robots play music, some others perform a play with music as background, etc. A jury will award points regarding the robot build up, programming, robot and team members dressing, subject chosen, number and type of sensors used, number of false stars, etc... Rules available on <http://www.robocupjunior.org>.

### 3.5 RoboParty – Educational Event

All robotics events consist of competitions between students who build the robots at school or at home. RoboParty [16] has a different approach because the robots are built in the event. It is an annual event organized by the Automation and Robotics Group [17] of University of Minho [18] and by SAR – Soluções de Automação e Robótica [19]. They developed from scratch a robotic kit to be built by people with no knowledge at all in robotics and called it Robot Bot'n Roll ONE [20]. In this event students are taught how to build a robot, how to program a robot, and they can also participate on an optional small competition.

The main purpose is then to teach and not to compete. This is dedicated to those people who want to learn how to build a robot.



Figure 14. Dance junior robot (Secondary)

Every year around February or March, 100 teams are accepted to participate on RoboParty which lasts for 3 consecutive days and it runs 24 hours a day. Teams are made up of 4 people (one adult and 3 youngster) ages between 10 years old and 19 years old. No one from the team needs to know anything about robotics, because there is a specially created training on the event to teach the first steps. In the last few years, some teams were made up of a family (mother, father and 2 kids).

The event consists of lecturing the basics of electronics (how to assemble an electronic board and they have to actually solder the components), mechanics (to build the structure), programming the micro-controller (to make the robot move). All these lectures were developed taking into consideration their age and lack of knowledge on robotics and therefore cartoons were used on the slides to explain simple basics. The teams is accompanied by some 50 volunteers (last year students of industrial electronics degree) in order to help them should some problem occur. In order to avoid an intense period of knowledge acquisition, extra activities also occur like horse riding, golf, tennis-table, football, woodball, basketball, cardio fitness, kick boxing, karate, yoga, indoor air modelling, circus activities, etc... Since so many participants came from so far, the organizing committee prepared 400 gymnasium mattresses and lay them down on the pavilion (parallel to the working area) where they can sleep. About half of them were so enthusiastic that did not sleep at all and continued working full night.



Figure 15. RoboParty training session



Figure 16. Participants assembling robots



Figure 17. Extra activities – Tennis table

In the last day, there are a few optional small competitions, where they can participate with the robot they built to test their capabilities. The competitions are:

**Obstacles** – The robot is placed in a small maze and it has to come out without colliding with the walls.

**Pursuing** - two robots are placed on a closed black line. Each robot has to follow the line until it catches the opponent.

**Dance** – Each robot has 90 seconds to perform a dance. The choice of music and choreography is chosen by the team.

**Engineering** – The robot is analysed by electronic engineers and they assess the quality of the build up.

**Aesthetic** – The most beautiful and original robot is the winner.

Awards are given to the three best qualified teams on each of these competitions. There are also sports competitions in parallel and the winners also receive awards.



Figure 18. Robots built on display



Figure 19. Pursuing competition scenario

Each participating team brings a laptop computer and sleeping bags, and they receive at reception a box with all parts to build the robot, manuals, t-shirts, canteen tickets, badges, posters, a form to apply to the extra activities, etc. After the competition the robot belongs to the team (they can take it home). They also take home an official RoboParty diploma stating that they successfully built the robot. The organization also guarantees that all robots leave the event fully working.

As bottom line the participants learn and build robots, learn many areas of knowledge, met new people, got souvenirs, met the facilities at the University of Minho (including sport facilities), and take a robot home with them. The building rate success has been over 95%. Some of these robotic platforms have been used in other robotic competitions (like RoboCup and Robótica) which means that the students continued developing the robots and improving the software to their needs.

#### 4. Main advices for beginners

For those teams who would like to start in these activities, a few advices are left here:

- **Robotic Kit** – Bot'n Roll  
([www.botnroll.com](http://www.botnroll.com))
- **Events** – RoboParty  
([www.roboparty.org](http://www.roboparty.org)) RoboCup  
([www.robocup.org](http://www.robocup.org)),  
[www.robocupjunior.org](http://www.robocupjunior.org)
- **Books**
  - Robots - From Science Fiction To Technological Revolution, by Daniel Ichbiah
  - Robot Building for Beginners, by David Cook
  - Robot Builder's Bonanza, by Gordon McComb
  - Absolute Beginner's Guide to Building Robots, by Gareth Branwyn
  - Intermediate Robot Building by David Cook
  - Robot Builder's Sourcebook, by Gordon McComb
- **Movies**
  - I, Robot
  - Robots
  - Wallie
  - 2010 space odyssey
- **Spaces** - Robotarium X, Alverca, Portugal

#### 5. Conclusions

It is important for young students to start working with science and robotics due to its multidisciplinary.

Mobile robotic competitions are important because students get very much involved on the subject, they work in group, they compare their work with other schools, etc. A competition is a good work form as it provides students a specific and stimulation goal. The projects are fun and stimulating so that the motivation and desire to make an effort in the course is high.

The main advantages in short term are that they participate in educational projects, students get more motivated to continue learning and they get competences in different scientific areas.

In long term, probably more students decide to continue their studies (at University level), there will be more chances of blossoming

technological companies, new technological solutions in civil areas, etc.

Participation on this kind of events is relevant not just for students but for teachers, not just because they can also learn but because the participating students are easier to teach.

#### 6. Acknowledgements

The author would like to thank everyone in the Robotics Laboratory at University of Minho for all the support given in the organization of many events. A special thanks for all the staff at the SAR – Soluções de Automação e Robótica.

All the organising committee and volunteers deserve the recognition of their work.

#### 9. References

- [1] <http://www.botnroll.com>
  - [2] <http://www.lynxmotion.com>
  - [3] <http://www.electronickits.com/robot/robot.htm>
  - [4] <http://www.trossenrobotics.com>
  - [5] <http://www.robotshop.ca/robot-kits.html>
  - [6] <http://www.kitsusa.net/phpstore/index.php>
  - [7] <http://www.robotadvice.com>
  - [8] <http://www.active-robots.com/products/robots>
  - [9] <http://www.usfirst.org>
  - [10] <http://mindstorms.lego.com>
  - [11] <http://www.eurobot.org>
  - [12] <http://microrato.ua.pt>
  - [13] <http://www.robocup.org>
  - [14] <http://www.est.ipcb.pt/robotica2009>
  - [15] <http://www.robocupjunior.org>
  - [16] <http://www.roboparty.org>
  - [17] <http://www.robotica.dei.uminho.pt>
  - [18] <http://www.uminho.pt>
  - [19] <http://www.sarobotica.pt>
  - [20] <http://www.botnroll.com>
- 
-

## **Day to Day Optics – An Overview of Science Activities About Optical Phenomena for High School Students Developed in the City of Ribeirão Preto – Brazil**

L. Bachmann and L.B. Mostaço-Guidolin  
Univ. de São Paulo, Faculdade de Filosofia,  
Ciências e Letras de Ribeirão Preto  
Av. dos Bandeirantes, 3900, 4040-901  
Ribeirão Preto – SP BRAZIL  
bachmann@ffclrp.usp.br and  
leila.bm@gmail.com

**Abstract.** The aim of this work it was to show to students and people in general that science is present everywhere in our daily life. Optics was chosen as a central theme because it is one of the most visual among the various sciences, and it is easily accepted by people. Ultraviolet radiation, visible light, and infrared radiation were considered in this work which is a part of one project that aims at science education in high school classes at Ribeirao Preto city – Brazil. We have developed three activities over the last year, focusing on the display experimental evidences related to optical phenomena in our day-to-day routine.

**Keywords:** optic, day-to-day, ultraviolet, experiments, high school, exploratorium.

### **1. Introduction**

Natural science phenomena can be found everywhere and every time. Unfortunately, we rarely search for explanations for the phenomena present in our day-to-day routine, or investigate the origin and the meaning of these phenomena.

Possibly due the mechanical behaviour of our life, the basic science that studies the more fundamental phenomena is forgotten; physics, chemistry, and biology can be coated with mathematical rules, thereby hiding observation and experimentation, which are activities constituting the development of critical sense.

The aim of this work was to show students and people in general that science is present everywhere in our daily life. We wanted to present science as a much more interesting topic than we imagine or conventional science classes teach us.

Optics was chosen as a central theme because it is one of the most visual are among the various scientific fields, and it is therefore easily accepted by people. Ultraviolet radiation, visible light, and infrared radiation were considered in this work, which is a part of a project targeting science education in high school classes in the city of Ribeirão Preto – Brazil. Over the last year, we have developed three activities focusing on the display of experimental evidence related to optical phenomena occurring during our day-to-day routine.

The first activity consists in a specific tutorial about ultraviolet light in our lives, clarifying its danger to our skin and eyes, such as correlation with cancer and erythematic formation, but also showing its major benefits to our body, namely vitamin D synthesis, influence in humour, and prevention of other cancerous processes.

The second activity comprises a seminar entitled: “Presence of science in our day-to-day life”, presented to some hundreds of high school students. For the students were given a mix of informal narrative and optical demonstrations happening routinely, such as the colours of our sky, clouds, sunrise and sunset, lens effects with transparent objects, infinite reflections between mirrors, just to mention some.

The third and last activity consists in an experimental exhibition in an Exploratorium, with thirty seven interactive experiments about light generation, interaction with our eyes, optical illusions, natural world phenomena, and explanation about technological apparatus. In the following chapter we will describe these activities with a short description of the methodology and the conclusions that we have achieved about this work [1].

### **2. Ultraviolet Radiation–Illumina-tion for our health**

A seminar about ultraviolet (UV) radiation was presented to undergraduate students and people in general. During the presentation, we mentioned more about the benefits rather than the downside effects of UV radiation. Nowadays, the negative effects of UV radiation are widely advertised in the media, but the benefits of UV radiation are left a side.

With respect to the benefits of UV exposure, we can list melatonin suppression regulating our biorhythms; vitamin D production helping salt fixation, e. g., calcium fixation in the bone;

melanin production, which protects us from excessive exposure to UV radiation, and various other reactions that are important our immune system [2].

Looking back into history, it is possible to conclude that the Sun has been probable present in our medicinal culture before since long the first registers were made. The - so called heliotherapy, a therapeutic approach using the Sun for medicinal purposes (our sole UV source before arc lamps), has been employed since the age of the Egyptian Empire. More recently, we can mention that between 1800 and 1920 heliotherapy was also in evidence. The year 1800 coincides with the discovery of UV radiation, firstly named moment as “Chemical Rays”, because this radiation produces more chemical reactions than visible radiation. Up to 1920, an unlimited number of protocols were developed for the treatment of diseases using only Sun radiation. Around 1920, heliotherapy came to a decline because results from a laboratory experiment revealed development cancer skin after excessive UV exposure. Nowadays, moderate exposure to UV radiation is recommended by medicine, taking the different exposure times and skin colours into account.

By discoursing on UV it was possible to show the public that our waking up in the morning is regulated by melatonin, but our modern lifestyle does not allow for this regulation because we live under artificial light sources, which suppress melatonin production, so this can be one reason as to why people do not wake up easily in the morning. In contrast, a child that has minimal influence of our urban modern live goes to be early, only some hours after sunset, and wakes up easily in the morning.

The seminar was conducted by focusing on the above theme. With the use of a very informal style of elucidation, it was possible to demonstrate the many interconnections between UV radiation and our lives. In the end, it was possible to observe that the knowledge of general people about UV radiation concerned only its negative effects and they believed only that sun should be avoided during the summer.

### **3. Science in our day-to-day life**

A 2-hour seminar about experimental evidence in our day-to-day routine was given to some hundreds of high school students. The activity was a mix of a very informal narrative,

projection of pictures onto a screen for contextualization, and some simple experiments shown during the seminar narrative.

During this second activity, we showed that it is possible to study experimental physics without a formal physics laboratory. In the beginning it was mentioned that we would emphasize the optical phenomena involved in our day-to-day objects only. We started by disclosing about very simple phenomena, such as light transmission through a transparent objects (e. g. ruler) and lack of transmission through white/opaque objects. With the presentation of this “phenomena”, the photon nature was questioned.

By making a comparison with other human senses, such as touch, we illustrated the situation by saying that our eyes can be composed of some prolonged and invisible members similar to the hand and the arms, so it is possible to identify objects with our eyes in the same way we can identify (touch) objects with our hands. To show these evidences, we suppose that some invisible device, which we named “Eye Rays”, emanate from our eyes. After longer discussions and explanations, we clarify that this was one of the photon theories in the beginning discourse about the photon nature, and only later were other theories detailing that the Rays emanate from the objects and not from our eyes exposed [3] [4].

After this historical explanation about the photon, other optical phenomena were exposed, including similar experiments which were displayed in the Exploratorium and will be presented in next section of this paper. This work shows a great possibility to taking ideas to the science class, and use objects that could help students interpret the theory and apply it to home-made physics experiments. Simple household utensils, as a spoon, can simulate one concave mirror at one side and a convex mirror at the opposite side; a glass of water can function as a lens; and a narrow cylindrical glass can work as a cylindrical lens.

This approach gives a historical narrative of optical discoveries and evidences optical phenomena taking place during a “one day routine”. Through out this seminar, it was possible to observe a great interest on the part of the students when the discussed phenomena were very evident in their lives but had never been thought of before, e. g., an image inversion through a cylindrical lens as observed in Figure 1.



**Figure 1– Cylindrical lens positioned over a statement “CHICO RALA O COCO” or “CHICO RALA O DEDO”; it is possible to observe the image inversion of the word “RALA” while the other words are symmetric and the inversion is not evident.**



**Figure 2 – Take care with your eyes.**

#### **4.1. Take care of your eyes**

#### **4. Optical experiments in a Science Exploratorium**

This activity consisted in an experimental exhibition in a public Exploratorium comprising thirty-seven interactive experiments about light generation, light interaction with our eyes, optical illusions, natural world phenomena, and explanation about technological apparatus. The display was open to the general public but the majority of the visitors were students aged between ten and seventeen years.

The exposition received the name “Light, Physics and Action” and aimed to stimulate the interaction of the visitors with all experiments. To achieve this objective, we chose activities with some special characteristics. First we exposed the experiments in a funny way, thereby changing the traditional way of teaching and describing the phenomena, while increasing the visitor’s interaction with the experiments.

Another approach adopted by us was that all experiments were accompanied by a small text explaining some interesting point of view, or by some important question to intrigue the visitors about fundamental meaning and providing them with an explanation about physical models that help us to interpret the observed results.

Finally, we chose low-cost materials to facilitate reproduction of most of the experiments, so that homemade activities could be implemented in schools.

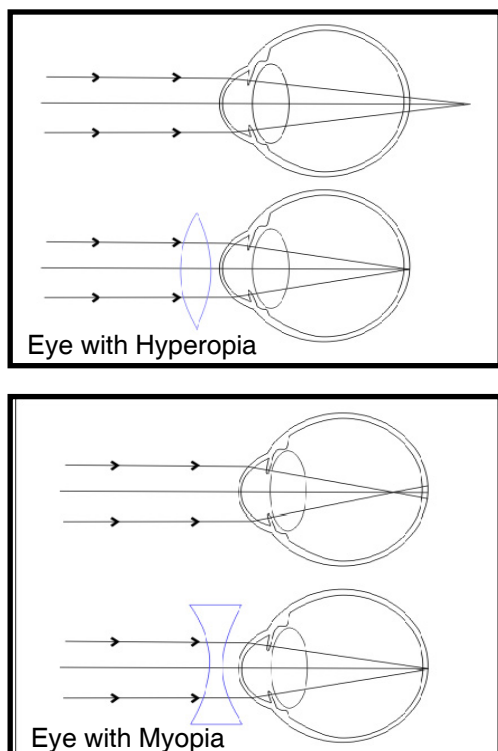
A brief description of these activities and experiments follows. This has been divided into sections, namely “Take care of your eyes”, “Homemade optical experiments”, “Homemade technological apparatus”, “Natural phenomena”, “Optical illusions”, and “Optics and Art”.

The first activity at the entrance of the Exploratorium consisted only of a two-meter poster with a close up of a child’s eyes (Figure 2). This poster urged people to take care of the eyes, not to look directly at the Sun, UV sources or laser systems. In this poster we also showed a big picture depicting the inner parts of the eye with some anatomical characteristics. We supposed that after reading this poster the visitor would take care with lamps and lasers used in the Exploratorium would also be aware of high intensity sources outside the exhibition. We distributed thirty seven experiments around the promise, which will be commented below. If the visitor interacted with the experiments linearly, we arranged them according the optical theory, starting from geometric optics, going on to technological apparatus, wave characteristics of light and finally light interaction with our visual systems leading to optical illusions.

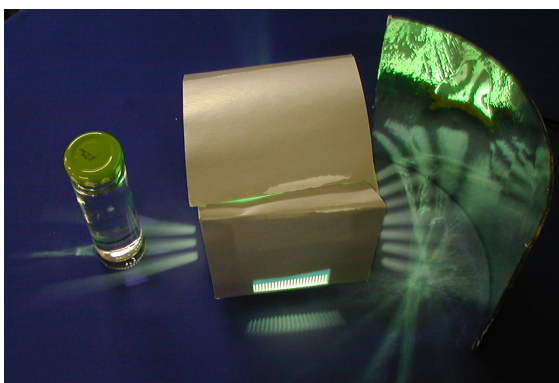
#### **4.2. Homemade optical experiments**

A group of experiments was designed to allow their reproduction at home, so they had to be risk-free, inexpensive, and only residential objects should be necessary to carry them out. Two examples of this group of experiments can be observed below. The first is the demonstration of the lens effect of a transparent glass of water (convergent lens) and an inner part of a big bottle (e.g. fizzy drink bottle) coated with a reflective paper (convergent mirror - see Figure 4).

A second example of easy homemade experiment is the production of multiple reflections with cabinet mirrors, present in bathrooms (Figure 5).



**Figure 3 – Upper figure: an eye with hyperopia and after lens correction; Lower figure: an eye with myopia and after lens correction.**



**Figure 4 – Convergent lens effect through a transparent glass of water and convergent mirror manufactured with the inner part of a big bottle coated with reflective naner**

For the latter experiment only two mirrors are necessary. One must be placed in that front of the other to produce the multiple images.



**Figure 5 – Multiple reflections between two cabinet mirrors**

Other experiments exposed in the Exploratorium are listed here: cylindrical lens manufacturing from narrow glass bottle filled with water or glycerine, concave and convex mirrors, disappearance of glasses with lens effect (putting one glass into another filled with glycerine).

### 4.3. Homemade technological apparatus

Technological apparatus were shown with the construction of very simple models of a periscope, eye-glasses, and two photographic machines: one with a pinhole and another with lens. To this end we built a dodecagon (see Figure 6). At one face, we introduced a lens, whereas in the opposite face we placed a semi-transparent paper for image projection. By choosing lens with a focal plane shorter than the distance to the semi-transparent paper we represent an eye with myopia; with a focus longer than the distance between the lens and the paper we represent a hyperopic eye. With specific lens, it is possible to simulate eye-glasses for myopia and hyperopic (see Figure 3).



**Figure 6 – Dodecagon manufacture for the myopia and hyperopia models with their respective corrective lens simulating the glasses that the people must carry. At the bottom is an instructive text in Portuguese to operate the experiment.**



**Figure 7 – In the upper image it is possible to see the blue Sky due to the gas molecular scattering; the scattering due clouds are due big particles as water vapor in clouds or due dust in the atmosphere that is more commonly at the horizon.**

#### 4.4.Natural world phenomena

The most popular optical phenomena observed in the nature are probably light refraction in a water drop and light scattering in the atmosphere. These phenomena are not known under these technical names, but if we start to talk about the rainbow (first phenomenon), and orange Sunset and blue Sky (second phenomenon), it will be very likely that every body knows them.

The light refraction that produces the rainbow can also be observed in the garden during irrigation, as shown in Figure 8. For this simple experiment, we must only learn in which position the observer must be placed stay to observe the phenomena: with the Sun positioned at the back and the irrigation in the front, and preference is given to the Sun positioned more horizontally.



**Figure 8 – Home-made rainbow during garden irrigation.**

A second experiment was proposed to show light scattering. In a water container with a few drops of milk we attach a white fluorescent lamp on one side: it is possible to observe a blue colour pattern in the lateral plane of the container while a red pattern it seen if you look to the lamp through the water-milk container in a frontal vision. This experiment will simulate the beautiful images observed in the natural world (Figure 7). In these figures we observe the



Rayleigh scattering, more predominant for the blue colour, and another scattering process, known as Mie scattering, which predominates in large particles like water vapour or dust.

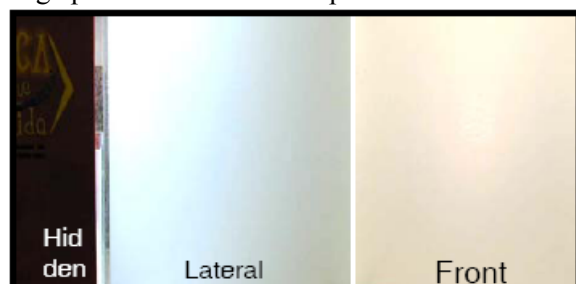


Figure 9 – With the lamp blocked by a book, it is possible to observe, at the lateral vision, a blue pattern of the light scattering by the milk.

#### 4.5. Optical illusions

In this group of experiments we demonstrate some optical illusions that happen in our visual system [5]. A common optical illusion in the natural world is the size of the Moon when it rises in the horizon. To demonstrate that this is an optical illusion, the following experiment can be proposed: After the Moon rises in the horizon at full Moon, and if the Moon seems bigger than the usual size, take a picture or measure it is size at a certain distance from your eyes. After some hours, take a picture in the same conditions and measure the Moon again. Finally, compare the picture and measurement with the Moon in the horizon: the size will be nearly the same. Other optical illusions were demonstrated in the Exploratorium and some explanations were given.

#### 4.6. Optics and Art

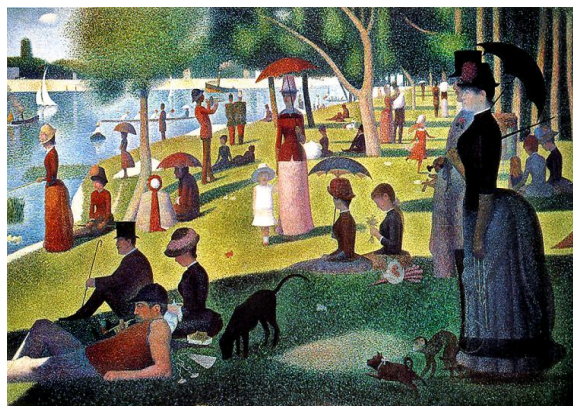


Figure 9– “Bar do Folies-Bergere” shows some optical unrealities

Among the exposed experiments we chose some paintings that use optical concepts. A famous one is the painting “Bar do Folies-Bergere”, from 1881, by Édouard Manet (1832-1883) (see Figure 9). In this painting, some optical unrealities are identified. The guest is invited to identify it! Another painting, “A Sunday Afternoon on the Island of La Grande Jatte”, from 1885, painted by Georges Seurat (1859-1891) (see Figure 10), used only small dots of primary colours. In the original painting, if you look at it from a close distance there are some black, white and green dots. Moving away, these points become more and more diffuse; black and green dots transform in to dark green, whereas white and green dots becomes light green. Basically, the colour mixing does not happen in the painting but in our visual system.

#### 5. Conclusions

These activities performed during 2008 and 2009 in Ribeirao Preto/Brazil give us the possibility of evaluating future approaches to increasing the dissemination of science among high schools students, Exploratorium experiments and seminars for general the public.



**Figure 10 – “A Sunday Afternoon on the Island of La Grande Jatte” use only dots of primary colors; the mixture of colors occurs in our visual system, not in the painting.**

Our conclusions after carrying out these activities is that the major impact on students, teachers, and general public consisted in the interaction of light with our visual system and the consequent brain interpretation, producing optical illusions; i. e., “you don’t see what you would expect to see”. As mentioned before, the second great impression was the explanation of optical phenomena present in our everyday life but never thought of before. Finally, experiments that are funny, such as the cylindrical lens over a statement are very motivating. The inversion of letters is not evident in the first moment, but it is easily accepted after the explanation.

## 6. References

- [1] J. Vanleave’s. Physics for every kid Jossey-Bass Publisher; 1991.
- [2] D. Downing. Day light Robbery – The importance of sunlight to health. Arrow Books publisher; 1988.
- [3] N. J. Wade. Descriptions of visual phenomena from Aristotle to Wheatstone. Perception 1996; 25:1137-1175.
- [4] M. Piccolino and N. J. Wade. Galileo’s eye: a new vision of the senses in the work of Galileo Galilei. Perception 2008; 37:1312-1340.
- [5] E. R. Churchill and J. Michaels. How to make optical illusion tricks & toys. Sterling Publisher; 1990.

## Callus Induction from Different Parts of *Nigella sativa* L. Seedling under Stress Conditions

I. Zareen Ahmad, A. Kamal  
and N. Fatima

Department of Biotechnology, Integral  
University, Dasauli, Kursi Road, Lucknow-  
226026 Uttar Pradesh, INDIA  
iffat77@rediffmail.com

**Abstract.** *Nigella sativa* L. belongs to family Ranunculaceae. The plant is cultivated for its seeds which are almost entirely used for edible and medical purposes, such as spices and for treatment of various diseases. The seeds contain fixed oils, essential oils, alkaloids, steroids and phenolic compounds. Thymoquinone is identified as the main anti-microbial principles of the plant. *Nigella sativa* seeds were investigated for a wide range of biological activities like antioxidant, anti inflammatory, immunomodulatory, anti ulcer, anti parasitic anti tumour, anti cancer and antimicrobial activity of seeds extract or its essential oils.

In vitro plant cultivation is nowadays important technique not only in plant propagation, but also in adult plant regeneration, which facilitates rooting and makes easier the propagation of a number of species. Plants as well as their cultures have been shown to synthesize antitumour alkaloids, amino acids, proteins antibiotics, fatty acids, various enzymes steroids precursor, etc, which are of immense use in pharmaceutical industry. There are reports of cultures that over-produce metabolites compared with the whole plant. Thymol production from callus culture of *Nigella sativa* has been reported.

The germination of *Nigella sativa* seed has been standardized and the study of callus tissues from different parts of the seedling been investigated in the present study. The role of auxins and cytokinins in inducing callusing has been examined. Plant cell culture is viewed as a potential means of producing useful plant products such that conventional agriculture, with all its attendant problems and variables, can be circumvented. The compounds such manganese chloride, cellulose, pectin and chitin were added to the medium for callus induction. These compounds act as elicitors (10mg/l) as they elicit the transformation/synthesis of some novel bioactive compounds in cell cultures. The

scientists have reviewed possible correlations between stress and secondary metabolism in cultured cells.

The seed imbibed water for two days, started sprouting on 3d developing into complete plantlet on 11d. Calli were developed from leaf, root, hypocotyl and epicotyl segments of *Nigella sativa* seedling. The segments from different parts (0.2cm) were inoculated on Murashige and Skoog medium supplemented with various growth regulators. Naphthaleneacetic acid (2mg/l) and benzyl amino purine (0.5mg/l) gave the best callusing response. The callus showed varied response when sub cultured under different stress regimes. The calli were maintained for different periods by subsequent subculturing and without subculturing for the determination /estimation/ identification of different bioactive compounds. Growth index were calculated at the time interval of every week on wet weight basis.

In one set of experiment salts of heavy metals such as  $MnCl_2$  was added to the culture media. These salts induce stress conditions and it has been well known that stress leads to induction of enzymes for secondary metabolism. In separate set of experiments various precursors / intermediates of various metabolic pathways like glycerol was added to introduce -OH group in some compounds and source of energy and fatty acids. Chitin and pectin were added as microbial infections of intact plants often elicit the synthesis of specific secondary metabolites.

**Keywords:** *Nigella sativa*, callus, elicitors, stress, bioactive compounds.

---

---

## Science Communication through Hands-On Activities

P. Iyamperumal

Executive Director, Tamilnadu Science and Technology Centre, B.M. Birla Planetarium, Gandhimandapam Road, Chennai – 600 025  
tnstc@md5.vsnl.net.in

### Introduction

Science Centers are influential in providing education on modern science and new technologies. It is obvious that formal education has an important role to play. In this regard, Tamilnadu Science and Technology Centre are actively engaged in supplementing and complementing formal science education imparted in schools and colleges. Tamilnadu Science and Technology Centre a nodal Centre in the region of Tamilnadu, India is ceaselessly engaged in science popularization activities through its Science Museums and planetariums at Chennai and Tiruchirappalli. It has the potential and plans to establish more Science Museums in the state of Tamilnadu. Our interest is to encourage and support the links between the media, the public, and the scientific institutions. Tamilnadu science and Technology Centre works with a keen view to build an effective and democratic Indian Knowledge society, and with the aim to stimulate the harmonious integration of scientific and technological endeavour in the Indian social web. The development of our society largely depends on its capacity to create, exploit and disseminate knowledge and, from there, to continuously innovate. Scientific research plays a major role in this regard, and should continue being one of the driving forces in promoting growth, welfare and sustainable development.

Hence for the prosperity of a nation, people with science and technology knowledge are crucial. Considering this we realize the enormous responsibility of Science Centres in making the citizens Science literate. Our country has a unique place in the world for its cultural heritage and human values. The greatness of our past and the social values alone can not help us and our young students to succeed in the knowledge based world. To make our country powerful existing competencies of our youngsters in the

fields of Science and Technology have to be enhanced.

### Science Shows and demonstrations

While teaching science, if it appears out of context and irrelevant to their lives, many students lose interest. If a student's motivation is ignored, even the most careful preparation on the part of the teacher will be wasted. Knowledge is defined as the familiarity gained by research and experience. As per the ancient Chinese adage '**I read I forget; I see I remember; I do I understand**', learning by doing is considered the best way in education. It is a well known fact that the learning experience for the young students needs audio-visual stimulation, especially when studying complicated scientific topics and astronomy. Truth is cognizable by the five senses of man and by reasoning based there on. The scientific concept taught by stimulating more than one sense will be retained by the mind effectively.

Psychologically, more pathways of locating the stored information will be formed in this approach. Also, individual students will have different strengths in receiving information through various senses. Some people prefer auditory or visual learning styles; others prefer a hands-on approach. Those with learning disabilities will also benefit from this multiple senses approach to education

One of the main objectives of Tamilnadu science and Technology Centre is to supplement the Formal Science Education given in the Schools and Colleges. In order to achieve this, and with the awareness of the effectiveness of the multi-sensory perception, and to involve the audience in the communication attempts, science show presentations are researched, prepared and presented at Periyar Science and Technology Centre.

The casual visitors to the Science Centres and creating a questioning mind-set in them can prove successful in science communication.

Tamilnadu Science and Technology Centre are continually organizing Science shows and Demonstrations lectures regularly at its Centres at Chennai and Tiruchirappalli and also at various parts of the state of Tamilnadu. At the Centres of Tamilnadu Science and Technology Centre on every Saturday time between 3 and 4 p.m. is earmarked for Hands-on Science Shows.

Concepts from Physics, Chemistry are taught during that time with demonstration of simple experiments by the trained scientific staff.

At other parts of the state, special two-day workshops are organized by the officials of Tamilnadu Science and Technology Centre to train the science teachers to perform hands-on science shows.

The following are the points considered in designing the science shows and notable advantages of conducting them.

- Audience Participation
- Infusing Investigative skills: Asking how? Why? etc.
- Curriculum links
- Ideas and Evidence in Scientific Concepts : Observation & Measurements
- Educational Merit and entertainment value.

While teaching science, the teachers pay attention to the teacher-learner interaction, learner-learner interaction and more importantly, the content-learner interaction. To make the content-learner interaction to be interesting, the methodology must be lively with student participation and entertainment oriented. In this way the Science Shows supplement the science education at Schools.

### Computer Aided Shows

The future belongs to those who will understand and use science and technology in ways that we can only imagine today. The grand transformation of society through computers that we have witnessed in the last decade is only the infancy of the information revolution.

Simplest form of science communication can be offered to the primary school level students through play-way by means of digital computers. They provide an engaging, educational hands-on interface, with clear, consistent navigation and interactive educational science activities.

Plausible Effects of Computers in Science Education

- New concepts of studentship, in terms of needs and responsibilities; allowing students to communicate with the Scientists;
- Fun way learning
- Multimedia experience of Science facts and experimentation

- Mobilizing scientific resources and creation of sharable worldwide science resources;
- Gauging responses to enable evaluation of the effect of learning;
  - Meeting the true needs and welfare of the students;
  - Enables new opportunities for development of new science education concepts.
  - The resources can be made reachable to almost all the places of the country.

In Periyar Science and Technology Centre, Chennai and in Anna Science Centre, Tiruchirappalli, Tamilnadu science and Technology Centre has installed computer assisted interactive hands-on kiosks in coordination with IBM. Bearing the name 'Try Science Kiosks' their shows offer : Adventure—interactive experience in Science ; Experiments—hands-on scientific activity ; Field trips—visit science centers throughout the world ; Curious—investigate scientific topics in the news ; Live cams—offer a real-time look at some of the world's most interesting science and technology exhibits. During evening hours, between 3 and 5 p.m, the web-portal in this exhibit is kept open to enable the visitors to browse the web, communicate with their friends, to view the exhibits in other science centre etc. Using the Computer Kiosk, children, parents and teachers have instant, continuous access to the best information and interactive experiments from more than 600 of the world's finest museums. IBM created the site, in collaboration with the New York Hall of Science and the Association of Science-Technology Centers (ASTC). In this type of Computer assisted learning tools we find features such as science experiments, that can be conducted on- and off-line, field trips to science centers throughout the world, exciting adventures in science, etc.

A gallery is dedicated for Information Technology at Periyar Science and Technology Centre. The developments in the field of Computers and IT are described there. In addition, several computers with an assortment of learning software are provided there for the visitors. Using them one can learn Science and Technology subjects at different levels, primary school level to advanced post-graduate level. One of them is Edinburgh Herriot-Watt University's 'The SCHOLAR programme' which provides common educational resources

and a 'virtual college' support network. Designed to improve student choice and flexibility, it helps students' progress between school, college and university. SCHOLAR materials have been specially written by subject specialists from schools, colleges and the university. They bring together the best of innovative learning with tried-and-tested educational approaches.

### **Shows for the general public**

The planetarium is an indispensable tool for teaching the spherical astronomy, the foundation for learning astronomy. The concepts of celestial sphere, local meridian, transits of celestial objects, the non setting circumpolar stars, celestial navigation, the altitude-azimuth and universal coordinate systems and many more concepts can easily be taught. Without the planetarium, it will be very difficult to make the young minds understand these concepts. Tracking the motions of the sun for different dates and at different latitudes, showing the changing apparent stellar motions in the sky at different latitudes, explaining the reason for having non setting Sun for six months and unavailability of the direct sunlight for the six winter months at polar-regions can be done very efficiently at the planetarium. The precession of earth's axis of rotation, the changing pole stars, the relative movement of the planets and their retrograde motions etc. are some other interesting visuals in the sky theatre of the planetarium.

### **Shows for School Students**

Since its inception in 1988, the B. M. Birla Planetarium, Periyar Science and Technology Centre, Chennai has produced 40 shows. While producing a show, the requirements of the students, school level students in particular, are given priority. The syllabus at high school level has portions on basic astronomy. To make the shows tailored for the students, we may incorporate the materials available in their text books in the script and elaborate them in the show with suitable special effects. The study by Dr. C. Sumners, Burke Baker Planetarium, Houston Museum of Natural Science (see IPS 2000 Conference Proceedings, p42) shows that the correct answers to the set of questions on astronomy after a planetarium show were

significantly greater than the test conducted after a class room lecture. Hence, the astronomy and astrophysical portion of school curriculum may be taken up and dealt exclusively in a planetarium show to benefit the students.

The programmes produced at B. M. Birla Planetarium, Periyar Science and Technology Centre, Chennai, which are tailor-made to cover the curriculum of the students or prepared to provide maximum information on the topics discussed in the beginning of Section 2 will normally be lengthy. To allow time to the students to assimilate the ideas presented one after the other, a small pause with mild music and related pictures are presented. Further, to prevent the students to miss the points presented in the show and to keep their attention in the show, quiz contests on the topics discussed in the show are conducted immediately after the show and instantly prizes are presented. These contests are not a regular event but organized during special events like, Cosmonautics Day, Space Week, Chandrasekhar's Birth Anniversary, etc.

The planetarium is used to reinforce concepts that may have been learned abstractly through a textbook. We all know that watching the motions of the night sky is difficult in a city environment due to light pollution. Additionally, the planetarium can be used to visualize the motions of planets and stars over timescales of hours to days to months to millennia - profound concepts which must be experienced to be appreciated. The programmes should be devised in such a way that attending a planetarium show becomes a profound experience in which education happens not via an abstract lecture, but one grounded in physical reality. In this way, we see the planetarium as an enhancement of the overall experiences, not as a lecturing aid.

## Science Activities

To take the astronomy education beyond the planetarium dome, as we all aware, various activities are being devised and conducted at most of the planetariums in India. Some of the efforts of B. M. Birla Planetarium, Periyar Science and Technology Centre, Chennai, in this direction are presented here.

### Story telling under the sky – Activity

The interest in Astronomy, if kindled at tender years, it will last and grow forever in the minds of the children. In order to create interest

in Astronomy to the toddlers this programme is organised. In this, young children in the age group of 4-6 are invited along with their parents to the sky theatre of the planetarium. Simple facts in astronomy such as directions, star patterns are explained to them using the projectors. The mythological stories on the constellations, one at a time, are told to the children. Later they are requested to draw, at home, the points of lights in the sky and the connecting pattern. The pictures are reviewed and the salient features of the pattern are discussed in the next class. In this way, it becomes an ongoing process at the planetarium, which can train thousands of kids in a year.

### Astronomy Courses – for the school students

Many students are found to be very curious to know about astronomical facts. To encourage them, periodically astronomy courses are being organised for the students in the age group of 11-14 years, making use of their school holidays. These programmes are mainly activity oriented. Even though, illustrated lectures are presented on solar system, stellar evolution, galaxies, cosmology, etc. using slides, the students are encouraged to involve in the group activities. Activities comprise the following.

**Edible Solar System:** In this activity, a huge pumpkin serves as the 'Sun', gooseberries, mustard and other pulses serve as 'planets'. Students are provided with meter stick to put the planets in their respective positions. This gives them a fair idea about the real scale of the solar system.

**Sunspot Observations:** Normally for this activity, the safe sunspotter telescope is provided. The students are made to make observations with the Sun's sketch on their observing sheet. This activity is normally guided. The nature and sizes of the sunspots are explained directly and the limb darkening effect is shown and explained.

**Preparation of Sundials:** The concept of motion of the earth and its axial rotation are explained to the students using this activity. They prepare their own cardboard horizontal and equatorial sundials. The local and standard times are explained.

**Sky Theatre Activity:** The complicated concepts of celestial coordinate system are explained in side the sky theatre. The reason for seasons, the fact about unsetting circumpolar stars, the reason for continuous sunlight or

darkness in Polar Regions etc are explained here practically.

Night Sky Observations: In this the constellation identification is taught by observing without any optical aid. The telescopes, their drives, the functioning of the telescope are also explained in steps. The deep sky objects and planets are shown through the telescopes and explained. This is a group activity with groups swapping their different kinds of telescopes to understand them.

Hence at the end of the course, the student gets a good overall knowledge in Astronomy and his contacts with the planetarium are encouraged for future studies.

Astronomy Courses – for the General Public

This programme, known as ‘Universe in Nine Steps’ is an eight week course and is popular among the public. This is a continuous ongoing programme, very similar to the one for students. Keeping in mind their time availability, this course is conducted on weekends at evenings.

Measuring the Radius of the Earth – Activity

In about 200 B.C. a Greek Philosopher, Eratosthenes (276 – 195 B.C.) measured the circumference of the Earth, by measuring the angles caused by the Sun at noon on a same day at the places of Alexandria and Syene, separated by a distance of 5000 stadia, which is about 800 kms. The angle difference was  $7.2^\circ$

The size of this angle is proportional to the fraction of Earth’s circumference that lies between Syene and Alexandria. We can express this as follows.

$$7.2^\circ / 360^\circ = 5000 \text{ stadia} / \text{Earth's circumference}$$

In this method, Eratosthenes determined the circumference of Earth to be 40,000 km. knowing the circumference he found the radius of Earth as 6366 km. The correct values of the circumference and radius of the Earth measured by orbiting spacecraft are 40,070 km and 6378 km.

For the students to have the thrill and the feel of measuring the radius of the Earth experiments are arranged using Eratosthenes method. This involves coordination with other Science Centres at various parts of the country. In this activity specially designed 18 cm long gnomons with flat bases are distributed to the school students at various parts of the country through the Science Centres and Planetariums. Plumb lines are also provided to set the gnomon vertical.

Simultaneously, on the noon of a specified day, the students are being guided to make the observations of the shadow angles. The data are exchanged between the students at different cities. Knowing the distance between the cities of observations, students measure the radius of the Earth fairly accurately.

Reason for Seasons Activity

This activity is conducted on March 21 and September 22 on equinox days. The same gnomon used to measure the radius of the Earth is used here also. This activity involves schools of various parts of the state under the guidance of the planetarium professionals. The exact date of equinox is communicated to the schools. On that day, the students using a clock measure the length of the shadow and the time continuously. The time of shortest shadow (which occurs at local noon) tells them the longitude of the place of observation and the angle of the shortest shadow tells the latitude of observation.

While carrying out this activity, students get to know about the tilt of Earth’s axis, the reason for seasons, the connection between the local latitude and the altitude of the pole star, local time, standard time and many more on spherical astronomy.

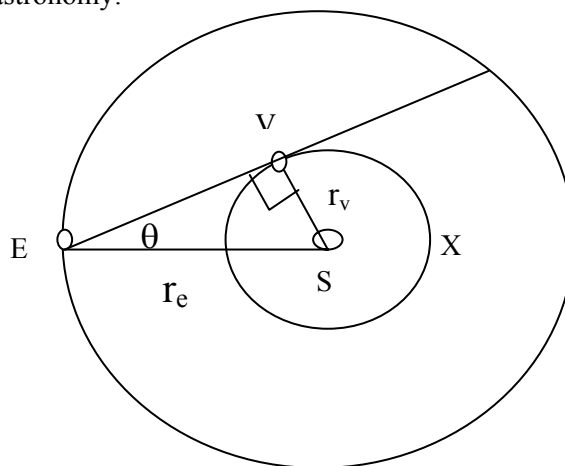


Fig. 1. Measuring the ratio of the sizes of the orbits of the Earth and the Venus ( $r_e/r_v$ )

This is another activity to train students in astronomical observations. Figure 1. represents the Sun (S) – Earth (E) – Venus (V) configuration at the time of maximum elongation ( $\theta$ ) of the Venus from the Sun. The elongation steadily increases from the superior conjunction point (X). At the time of maximum elongation, the line connecting Earth and Venus will be tangential to the orbit of the Venus and from the Venus, the Sun and Earth will be at right angle.

In this configuration,  $\sin \theta$  gives the ratio of the sizes of the orbits of the Earth and the Venus ( $r_e/r_v$ ).

$$\sin \theta = r_e/r_v$$

$r_e$  is nothing but the Astronomical Unit.

Students of the schools selected are provided with simple altitude azimuth meter made out of a protractor and a plumb line. They are instructed the methods to find the altitude and azimuth of the Venus and they recorded the time of observations. From these values, students compute the elongation of the Sun, each day, starting from the beginning date of observation. The students are normally very much successful in estimating the value of  $r_e/r_v$  accurately.

#### Mini Planetarium Shows

A team of planetariums constantly travel across the state to the village schools. The school students in the villages are shown a short planetarium programme using portable mini planetarium. Later they are involved in night sky observational programmes. During this programme, video shows and lectures on Astronomy are also arranged.

#### National and International Contests

The Planetarium at Tamilnadu Science and Technology Centre is a preferred centre for conducting national and international contests in astronomy. Every year hundreds of students are trained to face the National Astronomy Olympiad Selection tests. Later, the winners will be provided national level training and compete in International Astronomy Olympiads. Also the Centre provides training to contests like Red Rover Goes to Mars programme of NASA and the Planetary Society.

#### National Conferences on Astronomy and Planetarium Sciences

In order to exchange the experiences and views on Planetarium Sciences and techniques, National level Conferences on Planetarium Sciences are organized at Tamilnadu Science and Technology Centre. This provides a very good opportunity for the planetariums to interact and develop methods of presentations and new programmes for the public and students. In this programme, amateur astronomers are also invited and they are provided opportunity to interact with professional astronomers from various parts of our Country. Special invited lectures on Astrophysical researches and new developments in the field are also organized.

#### 3D Science Shows

Visible light seen around us are normally produced by atoms that are oriented in all possible directions in the light sources. Hence, the light-waves will be vibrating in all the directions. Such waves are known as unpolarized light. It is possible to transform unpolarized light into polarized light. Polarized light waves are light waves in which the vibrations occur in a single plane. Conveying to the general visitor the concepts of the wave nature of the light, polarization of light, polarizer and the stereoscopic vision will not be easy. However, after visiting the 3D shows shown at Tamilnadu Science and Technology Centre, they gain a general idea about these concepts. Before starting the show the official at the 3D theatre explains these concepts to the visitors and during the show they immediately gain the first hand experience of these facts. The shows are normally entertaining and designed to amuse the young visitors. While enjoying the thrill they wonder how this effect was produced. The explanation offered at the beginning of the show allows them to understand the reason.

#### EDUSAT Facility

Presently, an EDUSAT facility, a satellite linked classroom experience, has been incorporated at Periyar Science and Technology Centre, using which, the students get an opportunity to attend the lectures and experiments organised at a master classroom/laboratory. They even have the provision to interact with the subject experts. This is a classical example for ICT enabled Education.

#### Martian Rovers

Tamilnadu Science and Technology Centre, in collaboration with the Planetary Society and NASA, USA organised a training programme for the students in the year 2001 to prepare the students for the worldwide contest Red Rover Goes to Mars. In this programme a Tele-operable Rover with Internet connectivity was used to train the students of southern states of India. 100 students received training. Many of them were given training to operate the Rover at Chennai from their cities. As the real experiments on the Mars terrain will be Tele-operable, the training also devised to be remote operable. Out of the several thousands of students participated in the conference, the organizers selected 15 students to work with NASA for a short duration at the time of a Mars Mission, three were from the students



who received the rover remote operation training at Tamilnadu Science and Technology Centre.

### **Outreach Programmes**

In order to disseminate the information of Science and Technology among the general public and students community in particular, the Tamilnadu Science and Technology Centre has been extending good educational services through conducting various year round extension activities besides the permanent educational facilities like Planetarium, Halls of Science and Science Parks, established at Chennai and Tiruchirappalli. The following activities are conducted periodically, every year for the past several years.

#### Science Demonstration Lectures

Every week, on Saturdays, Science Demonstrations are conducted to supplement formal science education in Schools / Polytechnics. A good number of students attend this programme, in which using low cost innovative teaching aids science concepts are taught. The gadgets like nail bed, Liquid Nitrogen experiments, experiments on electricity, magnetism, sound, etc were developed and are being demonstrated free of cost.

#### Science Fairs

Science Fairs for the school students are conducted at least twice a year to stimulate ingenuity and encourage experimentation towards purposeful innovations. In this science competitions are also involved. These programmes are organised at various parts of the state.

#### Science Seminars

Seminars are conducted periodically for the School / Polytechnic / College students on the subjects of current interest.

#### Teacher Training Programmes to focus on Science Activities

This programme is conducted mainly to train and motivate the teachers for the stimulation of science activities among students.

Under this programme schools from all over Tamilnadu are invited and guidance and work facilities are provided to induce scientific inquiry leading to experimentation and innovations to direct the abilities of students towards materialization of their ingenuity.

#### Film Shows

Educational Films are screened on different areas of Science, Technology and Culture as regular features.

#### Health and Family Welfare Exhibition:

As a part of Women's Education Policy, these exhibitions find immense use particularly to the rural sector.

#### Meet the Scientist Programmes

This is a very popular programme among the students of this region. Scientists and Technologists are invited to share their knowledge in view to improve the focus and the attitude of the school children towards education, science and technology. Yearly, at least, 40 meet the Scientist programmes are conducted at Periyar Science and Technology Centre, Chennai and Anna Science Centre, Tiruchirappalli.

#### Meet the Medical Expert Programmes

To enable the student community to learn about the recent developments in the Medical field and also to motivate them leading Medical Experts are invited every month on last Friday to interact with the students on various topics, such as, diabetology, E.N.T., Ophthalmology, Cardiology, Urology, etc., The experts perform basic medical scanning to the interested participants on-the-spot.

#### Mobile Science Exhibition

To popularize science and technology themes to the general public, especially for the school children in the rural areas of Tamilnadu, the Mobile Science Exhibition with 24 built-in participatory type of exhibits, based on the various themes of science such as sound and hearing, sensation, perception, vision and illusions, has been in continuous operation since January 1990. Mini-Planetarium programmes are also conducted along with Mobile Science Exhibition wherever facilities are made available. Science Video Programmes are regularly screened in the evening hours during the programme periods. Over 16 persons have participated in the Mobile Science Exhibition programmes. During vacations, the Mobile Science Exhibition is conducted at the places of public gatherings like Arignar Anna Zoological Park, Vandaloor, Government Museum, Egmore etc.

#### Setting up of Science Parks

In order to give impetus to the process of popularization of science and technology among the student's community and general public in the rural areas, the Periyar Science and

Technology Centre has taken up the task of setting up of Science Parks in schools and in the different district headquarters.

#### Topical Programmes

Appropriate Scientific programmes are being chalked out to disseminate information to the student community and to the general public during special periods such as the Year of Scientific Awareness, International Year of the Earth, International Year of Astronomy, etc.

#### Temporary Science Exhibitions

The Centre participates in the All India Tourist and Industrial Trade Fair, being organised by the Tamilnadu Tourism Development Corporation at Island Grounds, every year and conducts the Science Exhibition displaying 50 exhibits in a separate pavilion of area 60' x 40'.

#### Science Programmes with Foreign Scientists

In coordination with the British Council, Chennai, Periyar Science and Technology Centre is organising lecture programmes by UK scientists and Science Fairs for School students every year.

In coordination with Alliance Francaise, Chennai, Periyar Science and Technology Centre are organising French Science Today programmes in which Scientists of various fields from France visit our Centre to deliver lectures on French Science Activities and new developments to the students.

Every year on the Cosmonautics day and on Valentina Tereskova's Birth Anniversary, special programmes such as quiz competitions, lectures and temporary picture exhibitions are arranged at Periyar Science and Technology Centre in collaboration with the Russian Cultural Centre, Chennai.

With the U.S. Consulate, Chennai the Centre conducts Science Lectures by NASA Scientists and Scientists from various other fields. Lecture by Mars Exploration Rover Mission Scientists, was conducted recently in coordination with them.

With IDP-Australia, Chennai teacher training programmes are organised periodically, in which teachers are taught about creating simple gadgets to demonstrate science concepts to the students.

## **Conclusion**

According to R. W. Emerson, 'A mind that is stretched by new ideas never returns to the same shape'. Science Centres have the ability to infuse new ideas among the minds of the visitors and to spark an interest in students. The main role of the science communicators is to help bridge the distance between the scientist and the public, between the individual and the universe. The Science Centre professional has assumed the role of both an educator and inspirer. The hands-on science activities mentioned in the paper can help the students in developing inquisitive mind and motivate them in learning science. Knowing that children have various notions, including unscientific thoughts, Tamilnadu Science and Technology Centre, using its Science Centres at Chennai and Tiruchirappalli, is continuously engaged in promoting activities described in this paper, to make them rational thinkers and to develop their personality.

To the Science museums of Tamilnadu Science and Technology Centre people of various nature and knowledge levels are visiting. It is not easy to predict the expectations of the individual, visiting the science museum. This makes designing a science show especially difficult. Hence, periodically feedbacks are being received from the visitors and they are being scrutinized to alter the science shows. Also the cafeteria approach in science shows gives good returns. Hence, science shows using lecture demonstrations, planetariums, computer kiosks, big format projections, etc. are being undertaken. In the lines explained throughout this report, research is continuously being carried out to develop more and more interesting shows on modern science concepts. Science communication efforts of Science Centres have enormously improved and yield productive results. The content in such cases must be carefully created to offer, in suitable quantities, the entertainment and the education, for which present day science communicators coined the term 'edutainment'.

---

---

## “The Earth from Space” Geosciences Information for Teachers (Gift) Workshop

M. Szepesi<sup>1</sup> and C. Stefureac<sup>2</sup>

<sup>1</sup>Goethe German High School, Bucharest

<sup>2</sup>“Mihai Bravu” Technical College,  
Bucharest, ROMANIA  
manuela\_szepesi@yahoo.com;  
crina.stefureac@gmail.com



Images of the entrance

**Abstract** Geosciences Information for Teachers (GIFT) Workshop, initiated in 2003 by the **European Geosciences Union (EGU)** was held in Vienna, April 19-22, 2009. It is a four days teacher enhancement held in conjunction with EGU’s annual General Assembly. The workshop for teachers of sciences (Physics, Geography, Chemistry, Biology, Geology) is organised by the Committee of Education of the European Geosciences. The participating teachers are selected using several criteria such as their daily

educational activity, their ability to speak English fluently and eventually a letter of recommendation on behalf of the school boarding committee. This year we had the chance to be selected.

The general theme of the 2009 GIFT workshop was “The Earth from Space”, the importance of observations of the Earth from space using meteorological and communication satellites. The program of each symposium, focused on a unique general theme, combines scientific presentations on current research in the Earth and Space Sciences, given by prominent scientists attending EGU General Assemblies, with hands-on, inquiry-based activities that can be used by teachers in their classrooms. As Vienna was the selected city for the meeting, the workshop began with a visit to the Museum of Natural History. Another highlight of the workshop was the visit of the United Nation Office for Outer Space Affairs in Vienna (UNOOSA). As in the preceding Gift workshops, the participating teachers could also present their work to their fellow teachers as the best way to start collaborations between teachers in the different nations.

The European Space Agency (ESA) has also provided each teacher with a copy of the School Atlas with the associated DVD’s allowing to extract and process the satellite data used for the Atlas illustrations, and with a copy of the secondary level teacher’s pack.



The value of bringing teachers from several nations together includes the potential for networking and collaborations, the sharing of experiences, and an awareness of science education as it is presented outside their own country. At all previous GIFT workshops teachers mingled with teachers from outside their

own country, had lunch all together mixed with scientists, and this provide rich dialogue for all those who participated since the dialogue included ideas about learning, presentation of content material, curriculum ideas. Therefore in addition to their scientific content, the GIFT workshops are of high social value.



During presentations

Such events occur annually. Information on: [www.esa.int](http://www.esa.int) and [www.esa.int/eduspace](http://www.esa.int/eduspace)

This year seventy-five teachers from twenty countries attended the workshop, including Romania as well.

We may say that these kinds of courses represent “Integration for Education and Education for Integration”. We also warmly recommend EGU and ESA to our colleagues.

**Keywords:** atlas, earth, education, geosciences, gps, research, satellite, space, the european space agency (esa), workshop.

## Solar Energy Workshops for Technical Students

J. Diz-Bugarín<sup>1</sup> and M. Rodríguez-Paz<sup>2</sup>

<sup>1</sup> IES Escolas Proval, Avda Portugal 171, Nigrán, SPAIN

<sup>2</sup> IES Tomiño, Solleiro s/n, Tomiño SPAIN  
javier.diz@edu.xunta.es,  
montserpaz@edu.xunta.es

**Abstract.** This article describes the activities of European Solar Days 2009 at IES Escolas Proval in Nigran (Spain). Several workshops related to solar energy and its applications were carried out during this celebration, including simple solar cookers construction and use, small solar-powered toys, solar electronic power supplies and applications, experimental parabolic cookers and exhibitions of electric vehicles.

**Keywords:** solar energy, workshop, electronics.

### 1. Introduction

The first ‘Tag der Sonne’ or ‘Solar Day’ was celebrated in Austria in 2002. The idea was then taken up by Switzerland and Germany and spread to other countries leading to the celebration of the first European Solar Days in May 2008, with the participation of countries like Slovenia, Belgium, Italy, France, Norway, Portugal and Spain. More than 4000 different events were staged in these European countries. The second edition took place on 15-22 May 2009.

In Spain it is organized by ASIT (Asociación Solar de la Industria Térmica), and contact and inscription can be made by its web page: <http://www.diasolar.es>



Figure 1. Solar Days Spanish brochure

This initiative tries to promote the use and knowledge of solar thermal, thermoelectric and photovoltaic energy throughout Europe. A wide variety of organizers are invited to join the initiative, like schools, research institutions, enterprises, cities and energy agencies.

Fig. 1 shows the Spanish brochure of European Solar Days and one of the toys made in our workshops.

## 2. European Solar Days in Nigran

As part of European Solar Days 2009 activities in Spain, IES Escuelas Proval of Nigran (Pontevedra) has programmed its First Solar Week from may 18 to 22. During this five days several activities and workshops have been carried out, like construction and use of solar cookers, design and construction of small toys powered by a small photovoltaic cell, solar home powering, electric vehicles and exhibitions of different solar devices and applications.

The detailed program of activities can be found at:

<http://centros.edu.xunta.es/iesescolasproval/enerxias/diasolar.html>

These activities have been organized by teachers from the Departments of Electronics, Technology and Design with the collaboration of the local company NORBIKE SL that furnished electric vehicles and its experience.

Fig. 2 shows some of the materials employed during the activities, like a parabolic cooker and photovoltaic electrification kits.



Figure 2. Some of the materials used during the Solar Week

## 3. First Day: Solar cookers workshop

The first day of activities was dedicated to solar cookers construction and testing. Among the wide variety of models existing we decided

to make the Fun-Panel cooker. This cooker has a very simple design and construction and can be made with cheap and recycled materials. This model has been adapted by Dr. Celestino Ruivo (Univ. Algarve) to achieve a better performance in colder climates like Portuguese and Spanish.

The first part of the workshop was a theoretical presentation (Fig. 3) about solar cookers and how they can help stop climate change and prepare food in many situations, like refugee camps and natural disasters. It covered also a brief explanation about the technical properties of solar cookers like low temperature solar collectors, different types of solar cookers, design and construction, materials and how to use them in different countries and cultures.



Figure 3. Presentation about solar cookers

The second part of the workshop was the construction of fun-panel cookers by students.

The third part of the workshop was an exhibition and demonstration of use of the cookers in which it was planned to cook different meals. Unfortunately sunlight was not present at that time so this activity could not be made.

Fig. 4 to 8 show different stages of the construction process, like measuring and marking of polypropylene panels (Fig. 4), cutting and folding to get the proper shape (Fig. 5), application of glue and reflective sheet (Fig. 6) and final assembly of the whole cooker (Fig. 7).



Figure 4. Measuring and marking of panels

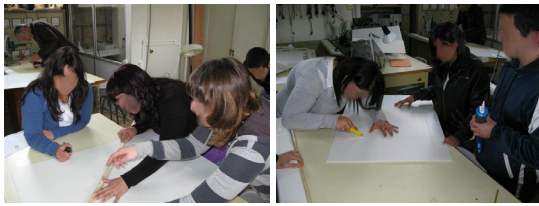


Figure 5. Folding and cutting of panels



Figure 6. Application of reflective sheet



Figure 7. Final assembly

Fig. 8 shows the exhibition of fun-panel cookers made in the workshop.



Figure 8. Solar cookers exhibition

#### 4. Second Day: Solar toys workshop

The second day of activities was dedicated to design, construction and testing of small photovoltaic toys, which we called 'fotosaltóns'. Fig.9 shows some of the basic prototypes and a commercial type (on the right).

Each student received a small photovoltaic cell and a micromotor with eccentric, of the same type that is widely used in cellular phones. Both elements can be seen in figure 10.

Students received also an instructions manual with a basic design to help them starting with their own creations. Older students with

electronics knowledge served as monitors to younger children.

Students had to design and build the body of the toy with materials of their choice, like cork, wood, carton, plastic, etc. Cells and motors were then glued and soldered to the body. When exposed to sunlight the toy would move and jump if properly designed, if not it remained quiet.

Fig. 11 and 12 show materials employed in the workshop, students making their own toys and assembling and testing of toys.

Fig. 13 shows several examples of toys made by students jumping and crashing together.

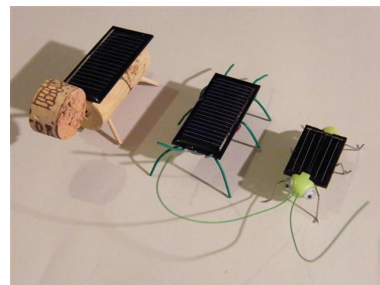


Figure 9. Some examples of solar toys

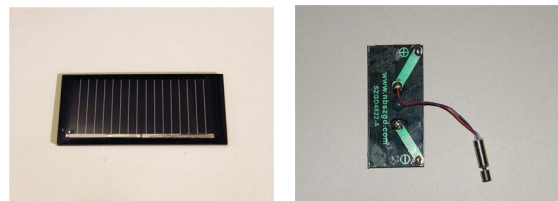


Figure 10. Miniature solar cell and vibrating micromotor



Figure 11. Materials and students at work



Figure 12. Assembling and testing

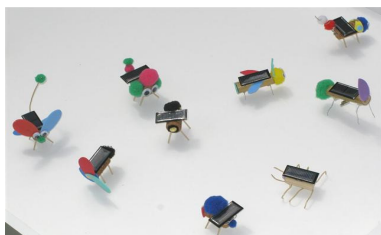


Figure 13. "crash test"

### 5. Third Day: Solar powering workshop

The third day there was a solar electronics workshop for technical students. The first part was a presentation about solar cells and panels, electronic devices for charging and regulation of batteries and applications.

The second part of the workshop was the assembling of different solar devices and kits, like:

- self made battery charger and regulators with switched regulator LT1074-LM2576.
- High power led devices (LUXEON) used for high efficiency lighting (Fig. 14).
- Solar lighting kit with 12V battery and 12V low consumption bulb.



Figure 14. High power leds and solar powered low consumption bulb

- Solar lighting kit with 12V battery, electronic ballast and fluorescent lamp (Fig. 15).



Figure 15. Fluorescent lamp with 12V ballast and lead-acid battery

- Solar electrification kit for small houses, made of a 10W solar panel, self-made charge regulator and modified UPS as charge storage and mains supply (Fig. 16).



Figure 16. Electrification kit with solar recharged UPS

### 6. Fourth Day: Solar prototypes workshop

This day was dedicated to construction of different prototypes of thermal solar devices, like solar collectors, solar cookers and others. The first part of the activity was a brief explanation about different types of solar collectors: parabolic and Fresnel concentrators, vacuum tubes and others.



Figure 17. Cleaning and preparing materials



Figure 18. Cutting reflective sheet



Figure 19. Applying reflective sheet



Figure 20. Finishing and testing reflector

The second part of the activity was the construction of a parabolic concentrator using a

recycled dish from an old parabolic antenna, which was covered with sheets of metalized polypropylene. The sheets were previously cut into triangular pieces.

The resulting concentrator is cheap and materials can be easily obtained. It can be used as part of a thermal solar collector or a solar cooker.

Figs. 17 to 20 show different stages of construction and final test of the concentrator, which consisted in burning a piece of wood.

## 7. Fifth Day: Electric vehicles exhibition

The last day of the Solar week there was an exhibition of electric vehicles. They were furnished by NORBIKE, a local distributor of this type of vehicles. First there was a presentation about history of electric vehicles, its characteristics and future. Then there was an explanation of the parts of an electric bike like battery, brushless motor and control unit (Fig. 21). And the last part was a practical demonstration of electric bikes that were tested by students and teachers (Fig. 22 and 23).

## 8. Future activities

This Solar Week can be considered as a starting point for many activities related to solar and renewable energies and environmental education. We are planning to continue with solar cookers construction and design of new thermal and photovoltaic applications.

In the field of electric vehicles, we have established a long term cooperation with NORBIKE Company and are planning to make the first recharging point for electric bicycles in our area.



Figure 21. Electric foldable bike from NORBIKE, SL



Figure 22. Electric vehicles and presentation

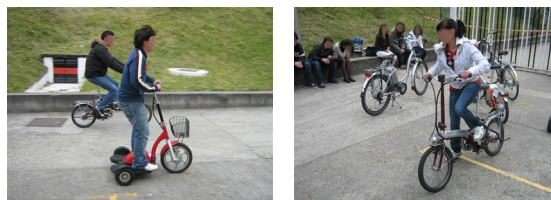


Figure 23. Students testing electric vehicles

## 9. Conclusions

- IES Escolas Proval has celebrated its First Solar Week from 18 to 22 of May, 2009 in coincidence with European Solar Days.
- Many activities have been carried out during these five days, like design and construction of solar cookers, solar lighting devices and small solar toys.
- Many students from all educational levels took part in these activities, contributing to knowledge of solar technologies and renewable energies.
- We consider that the Solar Week was a great success and are planning to continue with this kind of initiatives in following years.

## 10. Acknowledgements

The authors wish to thank all staff and students of IES Escolas Proval of Nigran and NORBIKE S.L. Company for their cooperation in the activities of the solar week. Also to Prof. Dr. Celestino Rodrigues Ruivo of University of Algarve (Portugal) that provided the design and plans of the modified fun-panel solar cooker.

## 11. References

- [1] Diz J, Obradoiro de cocinas solares. Parte I: Construcción dunha cocinã Fun-Panel, 2009. [http://solaina.es/drupal/files/obradoiro\\_cocin\\_a\\_solar\\_2009\\_0.pdf](http://solaina.es/drupal/files/obradoiro_cocin_a_solar_2009_0.pdf) [09/20/2009]
- [2] Diz J, Kit de electrificaci3n solar de baixo custo, 2009. [http://solaina.es/drupal/files/minikit\\_solar\\_artigo\\_gal.pdf](http://solaina.es/drupal/files/minikit_solar_artigo_gal.pdf) [09/20/2009]



- [3] Diz J, Manual: Construcción de fotosaltóns, 2009.  
[http://solaina.es/drupal/files/obradoiro\\_fotosaltons.pdf](http://solaina.es/drupal/files/obradoiro_fotosaltons.pdf) [09/20/2009]
- [4] Solar Cookers International, Solar Cookers: How to make, use and enjoy (10th edition), 2004.  
[http://images3.wikia.nocookie.net/solarcooking/images/5/57/CooKit\\_plans\\_detailed.pdf](http://images3.wikia.nocookie.net/solarcooking/images/5/57/CooKit_plans_detailed.pdf) [09/20/2009]
- [5] Solar Cookers International, Cocinas Solares: Cómo construir las y utilizarlas, 2009.  
[http://solaina.es/drupal/files/cocinas\\_solares\\_como\\_construir\\_las\\_y\\_utilizar\\_las.pdf](http://solaina.es/drupal/files/cocinas_solares_como_construir_las_y_utilizar_las.pdf)  
[http://images3.wikia.nocookie.net/solarcooking/images/8/81/CooKit\\_Plans\\_detailed\\_Spanish.pdf](http://images3.wikia.nocookie.net/solarcooking/images/8/81/CooKit_Plans_detailed_Spanish.pdf) [09/20/2009]
- [6] Aula de Energías Renovables do IES Escolas Proval (Nigrán), 2009.  
<http://centros.edu.xunta.es/iesescolasproval/enerxias> [09/20/2009]
- [7] Fundación Terra 2009.  
<http://www.terra.org> [09/20/2009]
- [8] Intermón Oxfam, 2009.  
<http://www.intermonoxfam.org> [09/20/2009]
- [9] Ingenieros Sin Fronteras (País Vasco), 2009.  
[http://cocinasolar.isf.es/camp\\_paneles.php](http://cocinasolar.isf.es/camp_paneles.php) [09/20/2009]
- 
- 

## Who Are Our Ancestors?

P.S. Bhavisha, B.M. Viralkumar, M.J. Vibhuti.<sup>2</sup>, M.B. Yogesh and S.T. Vrinda.  
BIT Virtual, The Virtual Institute of Bioinformatics, Saurashtra University, Dept. Of Biosciences, Rajkot 360005, INDIA  
[bhavisha.sheth@gmail.com](mailto:bhavisha.sheth@gmail.com),  
[viral\\_mandaliya@yahoo.com](mailto:viral_mandaliya@yahoo.com),  
[vibhuti115@gmail.com](mailto:vibhuti115@gmail.com),  
[yogeshbapodariya@gmail.com](mailto:yogeshbapodariya@gmail.com),  
[thakervs@gmail.com](mailto:thakervs@gmail.com)

**Abstract.** The most perplexing question with respect to evolution is that of our ancestry. The roots of the mankind could be traced back to the chimps or the monkeys although it varies with the other clades of life like the flora. An emerging field of Science--- Phylogenetics has simplified the ways to answer this age old question by interpretation of the history of organismal lineages as they change through time. Macromolecules of life viz. DNA and protein act as tools for deriving the phylogeny of life on the planet. The present paper highlights the use of Bioinformatics to interpret the organisms' evolution through phylogeny.

**Keywords:** bioinformatics, cladistics, dna, phenetics, phylogenetics, protein

Once a kid asked his mother "Manushya (human beings) originated from?" the mother replied "the term Manushya originated from Manu who is assumed to be the first human being on earth according to the Hindu philosophy", the child was surprised and asked again "but daddy replied that we evolved from monkeys!" Mother smiled then and replied "that's because, before marriage, me and your dad belonged to different families."

On a serious note, the most perplexing question of all life on earth is regarding its ancestry. The quest of history of our family associates is outlined as normally monkey or gorillas, but the answer itself ask for explanation that is what required in any scientific discourse.

Evolution is regarded as a branching process, whereby populations are altered over time and may speciate into separate branches, hybridize together, or terminate by extinction [1, 2]. The notion that all of life is genetically connected via

a vast phylogenetic tree is one of the most romantic notions to come out of science. Organisms have evolved through the ages from ancestral forms into more derived forms. New lineages generally retain many of their ancestral features, which are then gradually modified and supplemented with novel traits that help them to better adjust to the environment they live in. Studying the phylogeny of organisms can help us explain similarities and differences among plants, animals, and microorganisms.

The publication of Darwin's *On the Origin of Species* in 1859 led to a new approach to classification that attempted to unravel the evolutionary history of species. The closest species in this scheme are not necessarily those that show more resemblance, but those which share the most recent common ancestry [3].

### Drivers of Evolution

Evolution is gradual process occurring through a long span of time. Evolution is not always discrete with clearly defined boundaries that pinpoint the origin of a new species, nor is it a steady continuum [4]. Evolution requires genetic variation which results from changes within a gene pool, the genetic make-up of a specific population. A gene pool is the combination of all the alleles—alternative forms of a genetic locus—for all traits that population may exhibit. Changes in a gene pool can result from mutation—variation within a particular gene—or from changes in gene frequency—the proportion of an allele in a given population. Allele frequencies vary over time because of two conditions, natural selection and random drift. Hence, the Evolution and variation within the species evolved is in general driven by two major phenomena:

#### Natural Selection

Natural selection is the process whereby one genotype, the hereditary constitution of an individual, leaves more offspring than another genotype because of superior life attributes, termed fitness. Natural selection acts on genetic variation by conferring a survival advantage to those individuals harboring a particular mutation that tends to favor a changing environmental condition. These individuals then reproduce and pass on this "new" gene, altering their gene pool. Natural selection, therefore, decreases the

frequencies of alleles that reduce the fitness of an organism and increases the frequency of alleles that improve fitness.

#### Random Drift

The term random drift actually encompasses a number of distinct processes, sometimes referred to as outcomes. They include indiscriminate parent sampling, the founder effect, and fluctuations in the rate of evolutionary processes such as selection, migration, and mutation. Parent sampling is the process of determining which organisms of one generation will be the parents of the next generation. Parent sampling may be discriminate, that is, with regard to fitness differences, or indiscriminate, without regard to fitness differences. Discriminate parent sampling is generally considered natural selection, whereas indiscriminate parent sampling is considered random drift. Another important cause of genetic drift is the founder effect, the difference between the gene pool of a population as a whole and that of a newly isolated population of the same species.

### Phylogenetics

A phylogeny is a reconstruction of the evolutionary history of a collection of organisms. It usually takes the form of a tree, where modern organisms are placed at the leaves and edges denote evolutionary relationships. In that setting, species correspond to edge disjoint paths.

Phylogenies have been and still are inferred from all kinds of data: from geographic and ecological, through behavioral, morphological, and metabolic, to the current data of choice, namely molecular data [5]. Molecular data have the significant advantage of being exact and reproducible, at least within experimental error, not to mention fairly easy to obtain. Each nucleotide in a DNA or RNA sequence (or each codon) is, by itself, a well designed *character*, whereas morphological data (a flower, a dinosaur bone, etc.), for instance, must be encoded into characters, with all the attending problems of interpretation, discretization, etc [6].

Phylogenetics describes the genealogical relationships of living things. Molecular phylogenetics, also known as molecular systematics, is the use of the structure of molecules to gain information on an organism's evolutionary relationships. The result of a molecular phylogenetic analysis is expressed in a

phylogenetic tree. The result of a molecular phylogenetic analysis is expressed in a phylogenetic tree. Every living organism contains DNA, RNA, and proteins. Closely related organisms generally have a high degree of agreement in the molecular structure of these substances, while the molecules of organisms distantly related usually show a pattern of dissimilarity.

Molecular phylogeny uses such data to build a "relationship tree" that shows the probable evolution of various organisms. Not until recent decades, however, has it been possible to isolate and identify these molecular structures.

#### Phylogenetic trees

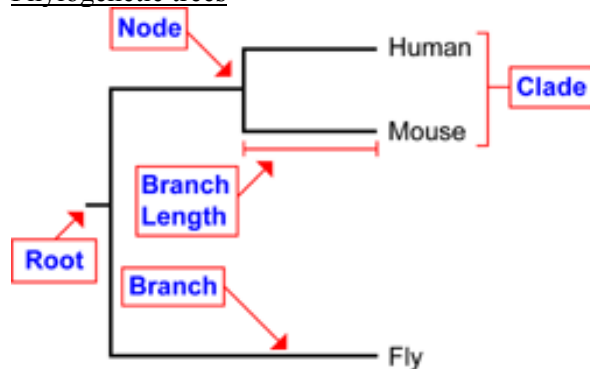


Figure 1: A typical Phylogenetic tree

A phylogenetic tree (Figure 1) is composed of nodes, each representing a taxonomic unit (species, populations, individuals), and branches, which define the relationship between the taxonomic units in terms of descent and ancestry. Only one branch can connect any two adjacent nodes. The branching pattern of the tree is called the topology, and the branch length usually represents the number of changes that have occurred in the branch. This is called a scaled branch. Phylogenetic trees may also be either rooted or unrooted. In rooted trees, there is a particular node, called the root, representing a common ancestor, from which a unique path leads to any other node. An unrooted tree only specifies the relationship among species, without identifying a common ancestor, or evolutionary path [7].

#### Methods of Phylogenetic analysis

Two major groups of analyses exist to examine phylogenetic relationships: phenetic methods and cladistic methods.

Phenetics, also known as numerical taxonomy, involves the use of various measures of overall similarity for the ranking of species. There is no restriction on the number or type of characters (data) that can be used, although all data must be first converted to a numerical value, without any character "weighting". Each organism is then compared with every other for all characters measured, and the number of similarities (or differences) is calculated. The organisms are then clustered in such a way that the most similar are grouped close together and the more different ones are linked more distantly. The taxonomic clusters, called **phenograms**, that result from such an analysis do not necessarily reflect genetic similarity or evolutionary relatedness. The lack of evolutionary significance in phenetics has meant that this system has had little impact on animal classification, and as a consequence, interest in and use of phenetics has been declining in recent years.

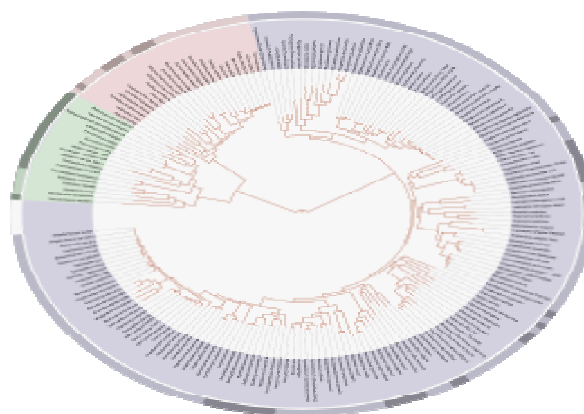


Figure 2: A highly resolved, automatically generated tree of life based on completely sequenced genomes [8].

The basic idea behind cladistics is that the members of a group share a common evolutionary history. Thus, they are more closely related to one another than they are to other groups of organisms. The development of cladistic techniques, combined with the usage of computers to analyze large quantities of data, have produced new insights into the history of life. Cladistic classification determines the evolutionary relationships between organisms by analyzing certain kinds of characteristics, or traits. In the course of evolution, a novel, heritable trait will emerge in some organism. That trait will be passed on to its descendants. Two organisms that share such a new, or derived,

trait or group of traits are therefore more closely related to each other than to organisms that lack those traits. By treating recently evolved characteristics differently from ancestral characteristics, this technique emphasizes evolutionary relationships over structural or morphological similarities.

Cladistics is now accepted as the best method available for phylogenetic analysis. It provides an explicit and testable hypothesis of organismal relationships. The basic idea behind cladistics is that members of a group share a common evolutionary history, and are closely related, more so to members of the same group than to other organisms [9]. These groups are recognized by sharing unique features which were not present in distant ancestors.

### **Molecules of Phylogeny**

The major macromolecules of life comprise of DNA, RNA, protein, lipid and carbohydrates. Amongst these, DNA, RNA and protein sequences retrieved from different databanks are used as preliminary requisites in phylogenetic analysis. The DNA sequences are used mostly in drawing the phylogeny although the protein sequences are having certain advantages like it minimizes some errors pertaining to codon bias, introns, RNA editing, etc.

### **Computational Phylogenetics**

Traditional phylogenetics relies on morphological data obtained by measuring and quantifying the phenotypic properties of representative organisms, while the more recent field of molecular phylogenetics uses nucleotide sequences encoding genes or amino acid sequences encoding proteins as the basis for classification.

Computational Phylogenetics comprises of the combined approaches of Molecular biology, Systematics, Taxonomy and Bioinformatics to explore the evolutionary basis of the living organisms. Computational phylogenetics is the application of computational algorithms, methods and programs to phylogenetic analyses. The goal is to assemble a phylogenetic tree representing a hypothesis about the evolutionary ancestry of a set of genes, species, or other taxa [10].

### **Steps of Computational Phylogenetics**

#### Collection of Sequence data

The initial task in deriving a phylogeny computationally is the retrieval of the sequences (DNA or protein) from the sequence databanks/repositories. The DNA sequences could be obtained from the repositories like NCBI (National Center of Biotechnology Information), EMBL (European Molecular Biology Laboratory) and DDBJ (DNA Databank of Japan). Similarly protein sequence data could be obtained from UniProt, etc.

#### Sequence alignment

Then the sequences so retrieved from the databanks are subjected to the process of Multiple Sequence Alignment using different programs like Clustal W, Mesquite, Muscle, Tcoffee, etc.

#### Phylogenetic tree reconstruction

The Multiple Sequence alignment generated in the above fashion also simultaneously generates phylogenetic tree which traces the evolution of the organisms included.

### **Bioinformatics' Databases and tools**

Bioinformatics is a comparatively new realm of science, which is capable of handling huge amounts of biological data with the help of sophisticated databases, softwares and tools. As more and more genetic diversity is being revealed through the completion of multiple genomes, an active area of research within bioinformatics is the development of comparative machine learning algorithms that can simultaneously process data from multiple species [11]. Through the comparative approach, valuable evolutionary information can be obtained about which amino acid substitutions are functionally tolerant to the organism and which are not. This information can be used to identify substitutions that affect protein function and stability, and is of major importance to the study of proteins [12]. Knowledge of the underlying phylogeny is, however, paramount to comparative methods of inference as the phylogeny describes the underlying correlation from shared history that exists between data from different species.

#### Databases

The chief databases among those available on the internet are:

▪ The Taxonomy Browser is an NCBI-derived search tool that allows an individual to search the Taxonomy database.

▪ The database of Clusters of Orthologous Groups of proteins (COGs) represents an attempt at the phylogenetic classification of proteins, a scheme that indicates the evolutionary relationships between organisms, from complete genomes.

▪ HomoloGene is a database of both curated and calculated orthologs and homologs for the organisms represented in NCBI's UniGene database.

▪ Uniprot Taxonomy is another database for the taxonomical classification of organisms at the Uniprot Knowledgebase, which is a protein sequence database.

#### Tools

The tools used are mainly classified as the multiple sequence alignment programs and the Phylogenetic tree visualization programs. The multiple sequence alignment programs widely used are ClustalX/W, Muscle, TCOffee, CLC Workbench, etc. The phylogenetic tree visualization programs which are most commonly used are TreeView, Dendroscope, TreePuzzle, etc.

#### **Concluding Remarks**

The studies of molecular phylogeny have provided new ways for measuring how closely or distantly related different species are on the evolutionary tree. These molecular tools have greatly aided evolutionary biologists in tracing ancestor-descendant relationships, which show how later organisms developed from earlier ones, among various organisms on the tree of life. Today, a survey of the scientific literature will show that molecular biology, genetics, evolution, development, behavior, epidemiology, ecology, systematics, conservation biology, and forensics are but a few examples of the many disparate fields conceptually united by the methods and theories of molecular phylogenetics. Phylogenies are used essentially the same way in all of these fields, either by drawing inferences from the structure of the tree or from the way the character states map onto the tree. Biologists can then use these clues to build hypotheses and models of important events in history.

The best results obtained in evolutionary studies often come from combining the

morphological and molecular analyses of different species with the modern bioinformatics techniques. The coupling of these approaches permit evolutionary biologists to build a more accurate picture of life's history within comparatively a sort span of time.

#### **References**

- [1] Dodson, E.O. & P. Dodson. 1985. *Evolution: Process and Product*. Prindle, Weber & Schmidt Publishers. Boston.
- [2] Mayr, E. 2001. *What evolution is*. Basic Books (Perseus Books Group). New York.
- [3] Marín A. W. 2003. *Phylogeny And Evolution*. *Lankesteriana* 7: 43-44.
- [4] Freeman S & J. C. Herron. 2001. *Evolutionary Analysis*. Prentice-Hall Inc. New Jersey. Harbor Laboratory Press: Cold Spring Harbor, NY.
- [5] Swofford, D.L., Olsen, G.J., Waddell, P.J., and Hillis, D.M. 1996. Phylogenetic inference. In *Molecular Systematics* (ed. D.M. Hillis, B.K. Mable, and C. Moritz), pp. 407-514. Sinauer Assoc., Sunderland, MA.
- [6] Wilson, A.C. 1985. The molecular basis of Evolution. *Scientific American* 253:164-173.
- [7] Fitch W. M & Margoliash E. 1967. Construction of phylogenetic trees. *Science* 155: 279-84.
- [8] Letunic, I. 2007. "Interactive Tree Of Life (iTOL): an online tool for phylogenetic tree display and annotation" *Bioinformatics* 23(1): 127-8.
- [9] Kenrick, P. & P.R. Crane. 1997. *The origin and early diversification of Land Plants: A cladistic study*. The Smithsonian Institution Press. Washington.
- [10] Mount DM. 2004. *Bioinformatics: Sequence and Genome Analysis* 2nd ed. Cold Spring
- [11] Siepel A & Haussler D. 2004. Combining phylogenetic and hidden Markov models in biosequence analysis. *J Comput Biol*, 11, 413-428
- [12] Knudsen B. & Miyamoto M. M.. 2001. A likelihood ratio test for evolutionary rate shifts and functional divergence among proteins. *Proc Natl Acad Sci U S A*, 98, 14512-14517

## Building a Secure Data Warehouse for e-Governance

V.N. Jokhakar

Veer Narmad South Gujarat University,  
Udhna-Magdalla Rd. Surat 395007, Gujarat,  
INDIA  
rao\_veena\_r@yahoo.co.in

**Abstract,** Data warehouse play a key role in the business intelligence and crucial decision making. These hold large set of data and are nowadays being used in almost all sectors for better decision making. As data warehouse is used for decision making purpose it must be taken care that the warehouse flexible, powerful, scalable and secured.

This paper advocates building a secured data warehouse for e-governance. As the implementing data warehouse in governance can drastically improve the working of government as help them in fast decision making for the betterment of the country as well.

**Keywords:** data warehouse security, multidimensional modelling, conceptual design, VPD, e-governance.

### 1. Introduction to e-governance and its applications

The term e-governance means computerization and automation of various services provided to the citizens who must deliver tangible benefits to them with low costs, rapid delivery of services that must also adhere to the laws and regulation of the government body using the application. Hence this term gives raise to government- to – citizens (G2C) also termed as government -to- public (G2P), government to business (G2B) and citizen to government (C2G) applications which are achieved by the help of information and communication technology. This leads to increase in efficiency, effectiveness, transparency and accountability of information and transactions between governments, governments and citizens at all the levels viz. International, national, state, municipal and local level and has been affecting globally.

There are many corporate agencies taking interest in making this initiative of e-governance

successful even by motivation students at college level by developing projects in open source for the same.

There are various e-governance applications currently present and also under development which are as follows:

1. E-railways: online booking/cancellation of railway tickets and for various railway information.
2. Loan management: various types of management of loan to backward class sector.
3. Crime control and management: the trouble spots can be identified with the help of GIS and crime related data.
4. Poverty Alleviation : identification of people below poverty group and helping them.
5. Welfare projects
6. Birth death monitoring system.
7. e-banking application for all government banks.
8. e-seva, card, voice – implemented in Adhrapradesh.
9. Automatic vehicle tracking, computerization of website of RCS office, electronic clearance system, management information system for education, online public grievances system – implemented in Delhi

These above listed are only few of the many systems that are available in Indian government and other states individually like maharashtra, tamilnadu, karnataka etc have implemented e-governance for the functioning of the government.

The paper has been organized as follows: Section II states the need of data warehouse, Section II states the security aspects for data warehouse, Section III shows the steps to build the data warehouse with security and Section IV concludes the paper.

### 2. Need of data warehouse

The term Data Warehouse was coined by Bill Inmon in 1990, and defined as: "A warehouse is a subject-oriented, integrated, time-variant and non-volatile collection of data in support of management's decision making process".

Currently in spite of all these e-governance application available the government decision

makers still lack a power system to help them make fast decision according to available information timely. As the data in these OLTPS keep on increasing as the population of the country also increases with time. As the definition defines data in warehouse are integrated from all the data sources available in the enterprise that could be structures, unstructured as well as semi-structured data and that it is non volatile i.e data stored are in read only form. It holds the historical data that are cleansed and transformed as per the need and stored in multidimensional structure. This makes them different from operational systems, is that information in operational systems hold the current data while in warehouse the data are integrated, transformed from all the relevant OLTPS and then is represented as subjects for storage as the requirements keep changing by time as users understand the usage.

Thus the by suing data warehouse, data can be integrated from all the departments and the decision at the country level for finance, security, external affairs etc. can be taken timely and rapidly.

Moreover aspect of security must also be incorporated in the design stage and must be a part of data warehouse life cycle also. In this paper, an attempt has been made to build a secure data warehouse for e-governance.

VPD has been selected as the tool to be used in the implementation phase that satisfies the security mechanism depicted at the design stage.

For this the data can be integrated from various systems such as transport department Excise duty, entertainment duty, professional tax, general hospital, co-operative banks etc. This integration can allow the government to get insight of the truth, views of the citizens, quality e-governance, efficient services and consistency in information. Each department should be able to only view the information for their own department, the data warehouse team can implement Virtual Private Database for the same.

Using VPD approach, each of the government departments will have respective 'virtual data mart'; from the perspective of the end-users within a government department.

### 3. Security requirements in data warehouse

Security must be built into the core of a data warehouse. [7]. Moreover aggregated and derived data usually look innocent to traditional security mechanisms, such as access control, and yet such data may carry enough sensitive information to cause security breaches.

It is known to all that the basic security must be applied to warehouse as it is done to other systems. Such as, data theft can be prevented by disabling unauthorized users accessing or modifying the data, as warehouse contains sensitive data too. It must also be taken care that these data are not available to everybody who use the system that is relevant data must to available to respective user. All the activities performed by the user must be logged for future concerns. As data warehouse contains integrated data at the enterprise level, this can lead malicious users to steel the data. So, a security at data base level could play a very crucial role to prevent data being stolen and modified by third party this leading to effectiveness or reduce the costs of a data warehouse environment.

Some typical customer scenarios for data warehousing security include:

1. A company is managing an enterprise data warehouse that will be widely used by many departments and stakeholders. That company needs a security infrastructure that ensures that the employees of each department and each stakeholder only be able to access the data that is relevant to their own scope, while also allowing for employees in its corporate offices to view the overall picture.

2. A company's data warehouses stores personal information. Privacy laws may govern the use of such personal information. Privacy laws must be implemented in the data warehouse to ensure protection of these kinds of data and prevent leakage.

3. A company sells data from a data warehouse to its clients. Those clients must be able to view the products that they have purchased or subscribed; they should never be permitted to see the data of other clients as the clients may be competitors.

As lot of communication takes place in a data warehouse system, creating the need for proper communication security measures. The data load

process (transferring the source data from requirements for a network infrastructure. Independent (possibly distributed) source databases have to be consolidated over a network. As the data may be highly sensitive it is essential to protect it from eavesdropping and similar secrecy threats.

#### 4. Steps for building a secure data warehouse fore-governance

Building warehouse for the government has to be done using bottom-up approach as the system as a whole will become very huge as we integrate all the data of the whole country from all the available systems. Hence the following steps are most suitable for developing a secure data warehouse at the departmental, state as well as national level.

Figure 1 depicts the basic bottom-up approach for developing a warehouse

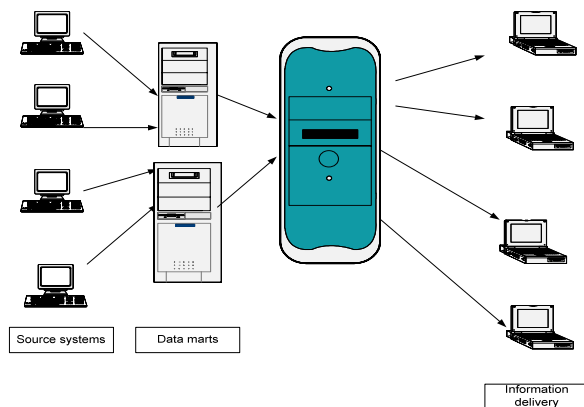


Figure 1. Approach of data warehouse

Step 1: Requirement gathering at the departmental level

Step 2: identification of data sources for the department say for example railway department

Step 3: Identification of facts as per the requirements and the business rules

Step 4: Identification of dimensions

Step 5: Identification of security at the access level

Step 6: Multidimensional modelling at conceptual level with security concerns.

Step 7: modelling of physical level design

Step 8: implementation of a data mart.

Step 9: implementation of information delivery components

Step 10 : Evaluation of the data mart

Step 11: repeating step 1 to 10 for creation of next data mart.

Step 12: integration of all the data marts are creating data warehouse in incremental phase.

Step 13: evaluation of each increment of the data warehouse.

For security at the access and role level VPD tool can be used to give security at the data base level itself.

Hence using the multidimensional modelling with security this warehouse can be designed with at most security and good design for better functioning of data warehouse.

#### 5. Conclusion

Data warehouse is a driving force for integrated data from heterogeneous sources of data that is used for enterprise wide view of data for taking decisions being used in almost all the disciplines. As the security is a major issue for this kind of storage as all the data now reside in a single repository, it must have security for data access in storage point of view. This paper has shown the importance of data warehouse, security needs in it and steps of implementing warehouse for e-governance and to be started early in the design phase that has been shown in this paper, for multidimensional modelling with VPD. Further, we also know that data is extracted from different sources and then integrated in warehouse, hence we need to specify the security at extraction, transformation and at physical design stages.

#### 6. References

- [1] Opim Salim Sitompul and Shahrul Azman Noah, A Transformation-oriented Methodology to Knowledge-based Conceptual Data Warehouse Design, Journal of Computer Science 2 (5): 460-465, 2006.
- [2] Laila Niedrite, Maris Treimanis, Darja Solodovnikova, Liga Grundmane, University of Latvia, Latvia. Development of Data Warehouse Conceptual Models: Method Engineering Approach 2007
- [3] Matteo Golfarelli, Dario Maio, Stefano Rizzi. Conceptual Design of Data Warehouses from E/R Schemes 1998 IEEE.
- [4] Rodolfo Villarroel, Eduardo Fernández-Medina and Mario Piattini, Juan Trujillo, A



UML 2.0/OCL Extension for Designing  
Secure Data  
Warehouses 2006

- [5] Matteo Golfarelli, Stefano Rizzi and Boris Vrdoljak, DEIS — University of Bologna, Data warehouse design from XML sources
  - [6] Juan Trujillo, Manuel Palomar, Jaime Gomez, university of Alicante, Il-Yeol Song, Drexel University, Designing of Datawarehouse from OO conceptual model, IEEE 2001
  - [7] An Oracle White Paper April 2005, Security and the Data Warehouse
  - [8] Paulraj Pulliah : Data Warehousing Fundamentals – Wiley
  - [9] S. Anahory & D. Murray: Data Warehousing in the real world – Addison Wesley
- 
- 

## Rich Internet Applications in Education

S. Divjak

University of Ljubljana, Faculty of  
Computer and Information Science,

SLOVENIA

sasa.divjak@fri.uni-lj.si

**Abstract.** In the first part of the paper the main differences between Rich Internet Applications (RIA) and classic hypertext pages are explained. Different technologies that enable such internet applications will be compared. In the second part of the paper some typical sample applications which have potential educational value and meaning are presented. In the last part of the paper the possibility of simulation of natural phenomena, mostly in physics is demonstrated. As a practical example the already known xyZET authoring tool which enables creation and simulation of physical experiments will be considered. The current java version of this program was converted to ActionScript 3 and the results of such conversion will be analysed and explained.

**Keywords:** education, rich internet applications, simulation

### 1. Introduction

The concept of Rich Internet Applications (RIA) is known for several years but the technologies that represent the basis of RIA are still in violent development. Rich Internet Applications are WEB applications which have some positive features of popular desktop applications but we usually access to them through WEB browser with appropriate plug-ins or through sandboxes and virtual machines.

What should be the characteristics of an application to be considered as RIA? Such WEB application should have a high level of expressiveness. Its usage is often motivated with intuitive interfaces and with inclusion of sound and visual elements.

RIA are usually (but not necessarily) running on user's computer (client computer) and this decreases the load of server. At the same time the user interfaces gain better responsiveness.

RIA together with other server technologies in some cases enables communication and data transfer in real time, if needed also sound and video.

One of the major benefits of RIA is platform independent delivery of contents. Some Rich Internet Applications are running inside a WEB browser and this permits the access to them from anywhere. They are frequently HTML and JavaScript based and such technology is known as Ajax.

On the other side desktop Rich Internet Applications decrease the gap between classical desktop applications and WEB technologies and in such a way offer more functionality.

There are different approaches how to implement RIA in educational processes. Some concepts are already well known to young people from the everyday experience and WEB entertainment: Facebook, YouTube and MySpace. RIA augments the flexibility of learners and improves their workflow in the classroom and outside it. In the classroom the learning techniques could be improved. One example could be represented by collaboration games which diminish the gap between the abstract and real world. The learners can get a better control on data by using intuitive interfaces. In such a way they get a better “feeling of ownership” on what are they doing.

## 2. Used technologies

Development of Rich Internet Applications is mostly achieved with Ajax, Flex and Microsoft Silverlight. The development effort is similar in all these cases. The first RIA was based on Ajax, which is in fact only a better integration of HTML and JavaScript.

Flex is based on popular Adobe Flash player which is usually already installed on most computers. The applications are programmed in ActionScript 3 and with development tools like Flex Builder and Flash Develop.

Silverlight is a Microsoft technology independent from a particular browser. The compatibility with .NET enables an easy development and usage. In analogy to Flex also Silverlight runs on a browser’s plug-in. This avoids compatibility problems however its popularity is currently smaller. Silverlight contents can be created with known and popular development tools, first of all with Visual

Studio.NET. A very interesting development tools is Microsoft Expression. The same project can include the code for server’s components and for corresponding players.

When we compare Flash and Silverlight we can conclude that Silverlight is more oriented in developers of applications and that Flash has origins to support animations. Open source Flex could be the step into the right direction.

## 3. Examples of RIA in education

Rich Internet Applications can support educational processes in various ways.

WEB based education and collaboration is more and more prevailing. An example of collaborative technology is Microsoft program Windows Live @ edu which is (still) not a true RIA but represents a bridge between WEB and desktop. Office Live Workspace represents an environment which merges WEB and desktop and enables collaboration between teachers and learners.

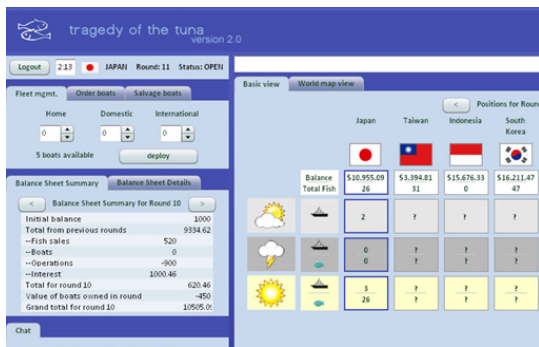
On Wharton School at Pennsylvania University the MBA students use RIA to select timetables of lectures. Before this they could use only classic WEB pages. Currently the data are created on basis of student’s reports and offer the information concerning the quality of professors and their seminars. This information can be used in student competition for most popular professors and courses. The application was developed in Flex.



Figure 1: Creation of a personalized time table using RIA

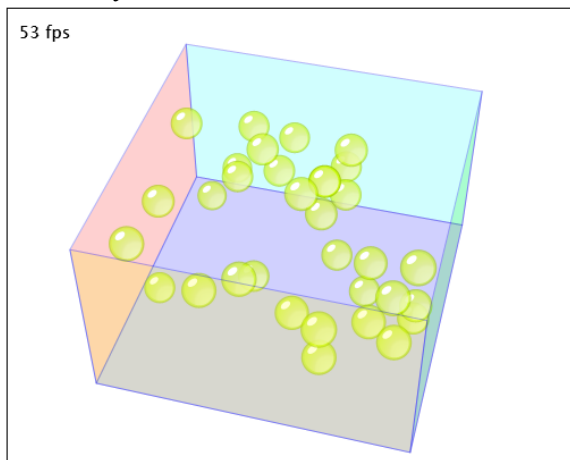
Learning Laboratory in Wharton School developed several classroom simulations, in fact collaborative games based on Flex technology. One such simulation entitled “Tragedy of Tuna”

is a typical example of “tragedy of common resources”.



Picture 2: An example of collaborative simulation game

Such common resources (for example air, water,..) could be exploited by everybody and nobody is responsible for their conservation. As people are not responsible for comfort of future generations this leads to tragedy. The mentioned example of Tuna Tragedy puts students in such position: every group of students represents a particular country with its tuna fishing fleet. They should balance their decisions that impact commonly shared resource.



[start](#) | [stop](#) | [gravity switch](#)

Figure 3: Simulation of Brownian motion prepared with SilverLight

Word processor Buzzword is another interesting WEB tool which enables sharing of documents and in such a way collaborative work. The documents are stored on WEB. A teacher could with a similar RIA supervise the assignments of his learners and eventually asses them.

We could also raise the question how RIA could be used in particular subjects. Such good examples are still missing. Flex and Silverlight

offer an environment which could use 2D – and 3D graphics for better visualization. This could be particular useful for various simulations of natural phenomena. Figure 3 shows a simulation of Brownian motion, developed with Silverlight.

Figure 4 presents a screenshot from a program for interactive visualization of vectors and geometric shapes in 3D space. Similar programs offer visualization of different functions.

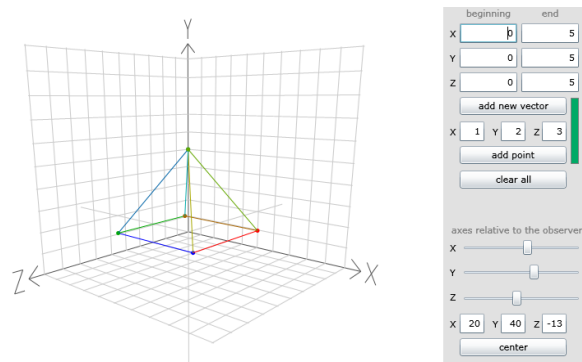


Figure 4. Visualization of geometric shapes in 3D space

#### 4. Case study: Conversion from Java to AS3

As a practical example of a complex simulation tool the known xyZET was considered. This program was first developed at IPN, University of Kiel for UNIX systems. Currently I was re-engineered in java (javaXYZ). The same program was now converted in ActionScript 3 (shortly AS3). Figure 5 presents a comparison of both versions. JavaXYZ was converted to AS3 with J2AS3 converter.

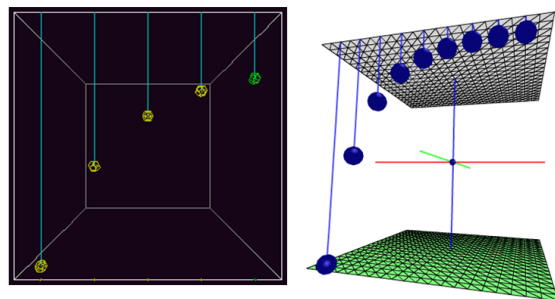


Figure 5: Comparison of java and AS3 version of XYZ

Another example demonstrating much better graphical capabilities of AS3 version of xyZET demonstrates the simulation of various orbits of a

satellite rotating around Earth. Various parameters and simulation itself can be controlled by JavaScript calls integrated in a tutorial hypertext.

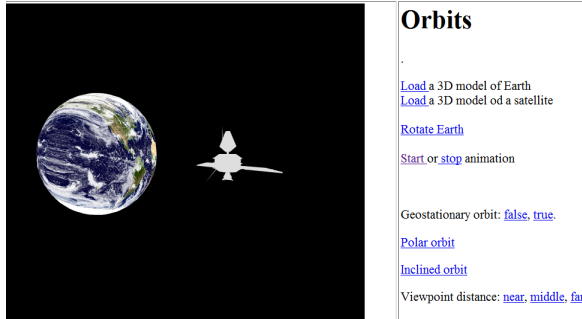


Figure 6: Orbits of a satellite rotating around Earth.

## 5. Conclusions

The initial experience with the capabilities of rich Internet Applications often lead to mistakes or misuse well known in usual creation of hypertext pages. Creators of such materials try to show their skills and knowledge with too many links, with exaggeration of different fonts, in strange colours and background textures, and sometimes with exaggerated animations within WEB pages. Do not fall into temptation to offer too much “richness”. To most of the users the usual model based on hypertext pages with limited interactivity is sufficient. The adaptation to new approaches is a process which requires time. New standards appear and take effect slowly. “Richness” should be added slowly and only where it improves usability. Research of user experience and usability verification will help us in decision how much richness is appropriate in a given time. We should think about when to use classical and when enriched hypertext.

Rich internet applications offer better audio-visual capabilities and a more effective collaboration in the classroom and outside it. In distance learning a better collaboration and contacts between the teacher and learners are facilitated. The teachers could submit the educational materials in digital libraries in real time. The learners could collaborate in team projects and in different environments: using personal notebooks, in computer equipped classrooms, using computers of their friends, ..

The conception to share our stuff on servers gives to our work and mobility new aspect. In a limited sense even our mobile phones could be

used. As mobile devices become better and better new challenges will be in front of us. In next years we can expect mobile reach internet applications. And this will extend the concept of classroom from the school into a pervasive environment.

## 6. References

- [1] Eric W. Orts. The Tragedy of Tuna, <http://www.wharton.upenn.edu/learning/tragedy-of-the-tuna.cfm>
- [2] Ryan Stewart. Rich Internet applications in education, <http://blogs.zdnet.com/Stewart/?p=601>
- [3] Ryan Stewart: RIAs: Rich Learning for Higher Education, <http://connect.educause.edu/Library/EDUCAUSE+Review/RIAsRichLearningforHigher/46322>
- [4] Sasa Divjak: Rich Internet Technologies, [http://colos.fri.uni-lj.si/SUMMER\\_SCHOOL\\_2008/GRADIVA/ria.ppt](http://colos.fri.uni-lj.si/SUMMER_SCHOOL_2008/GRADIVA/ria.ppt)

## New Era of Genetics: Good to Superior

B.M. Viralkumar, P.S. Bhavisha, M.J. Vibhuti, M.B. Yogesh and S.T. Vrinda  
Saurashtra University, Dept. of Biosciences,  
Rajkot 360005, INDIA  
viral\_mandaliya@yahoo.com,  
bhavisha.sheth@gmail.com,  
vibhuti115@gmail.com,  
yogeshbapodariya@gmail.com,  
thakervs@gmail.com

**Abstract.** The processes of natural selection and evolution have played an important role in diversifying life in all its forms, although the efficiency varies amongst them at large. The unity in the diversity is by far needed to bring the selective characteristics of more than one organism to a single but efficient one. Genetically Modified Organisms (GMOs), produced by the combination of the principles of biology and genetic engineering, have revolutionized the fields of biology, medicine, therapeutics and agriculture at large. The paper reports the review of the aspects of the new realm of Genetically Modified organisms like production, uses and applications.

**Keywords:** genetically modified organism, biotechnology, plant tissue culture.

### Introduction

Life on the earth occurs in various forms that are unicellular to multicellular organisms. Multicellular organisms such as plants and animals are made up of hundreds and thousands of cells while bacteria consist of a single cell (1). When cells divide during the growth of an organism the genetic material is transferred to new cells (2). The genetic material of an individual is made up of collection of genes (3). Genes are the factors that are responsible for desired product and functional characteristics. For example, in different persons with different eye colours like blue and brown eye, the colour of eyes is depending up on the genes that are present in an individual. The genes are made up of DNA (Deoxyribonucleic acid). Sometimes any alteration in the number or arrangement of these genes that either natural or artificial, leads

to formation of new trait that was not present earlier.

Advances in sciences have resulted in the growth of a wide variety of techniques, which result in genetic modification (4). Genetic modification is the process of altering the DNA in a cell (5). Often genetic modification involves isolating the DNA encoding a single gene from one organism and inserting it into the genetic material of another organism (6). The genes of desired characters were incorporated into an individual that adds a new trait in the individual. The new genes added organisms are termed as genetically modified organism or GMO. For example, if genes that responsible for orange colour in orange rose were incorporated in a cotton fiber, so garments made up of it will naturally having orange colour (Figure 1), so it can be eco-friendly. These techniques have been applied to a wide range of micro-organisms, plants and animals, resulting in increased scientific understanding of organisms, their interactions, genetics, and functions, as well as enabling production of enzymes.

### Preparation of GMOs

In nature genetic modification can occur when exogenous DNA penetrates the cell membrane for any reason. To do this artificially may require attaching the genes to a virus or just physically inserting the extra DNA into the nucleus of the intended host with a very small syringe, or with very small particles fired from a gene gun. However, other methods exploit natural forms of gene transfer, such as the ability of *Agrobacterium* to transfer genetic material to plants, or the ability of lentiviruses to transfer genes to animal cells.

The first reported recombination of genetic material was in 1973, so this technology is just over 30 years old (7). One of the first applications was the production of insulin by bacteria (insulin to be used for treating diabetics was previously derived from pig pancreas); the recombinant insulin product was approved by the FDA in 1982. The bacteria used for this purpose is a strain of *E. coli*, a common organism (it is a major bacteria in the human intestinal tract), into which the human insulin gene is inserted. The advantage of this technology is that the product matches human insulin exactly and it is cheaper

to produce; the pig product is more likely to cause allergic reactions.

Insulin production is started by the inoculation of a vessel of culture medium with a genetically modified *E. coli* bacterium (7). The *E. coli* have had a human gene spliced into their DNA compelling them to produce human insulin. The insulin is harvested by lysing the dead bacteria and then separating out the pre-insulin from the rest by centrifugation and filtration. The pre-insulin has then to be "folded" into its active tertiary structure by treatment in a refolding vessel with buffers of various concentrations. After enzymatic cleavage of this product and chromatographic separation, the insulin product is crystallized, deep frozen (under clean room conditions), and is then ready for fill and finish.

An example of genetic modification is the introduction of a gene from the soil bacterium *Bacillus thuringiensis* into the genes of a crop plant (8); the selected gene codes for a protein that is toxic to certain insects. This genes transferred plants were propagated by various tissue culture techniques. The genetically modified plants then produce the protein, making them resistant to pests like the European Corn Borer or Cotton Boll Worm. The successful examples are Bt cotton (9), Bt maize (10), Bt potato (11), etc. By using this technology, the yield of plants is higher (since fewer are damaged by insects) and the use of insecticides against these pests can be reduced. Other pest-resistant GM crops on the market today have been engineered to contain genes that confer resistance to specific plant viruses.

There are several examples of development of genetically modified animals. Genetically modified mice are prepared by change an endogenous gene. The method can be used to delete a gene, remove exons, add a gene, and introduce point mutations (12). Often it used to study cellular and tissue-specific responses to disease. This is possible since mice can be created with the same mutations that occur in human genetic disorders, the production of the human disease in these mice then allows treatments to be tested.

## Potential benefits of GMOs

Those promoting GMO use generally agree that technology has helped improve food production. For evidence, they point to the "green revolution" when agriculture became industrialized and large-scale fertilizer and pesticide use became common practice. GMO advocates believe that GMOs will continue this tradition of technology advancing food security for the growing human population (13). GMO proponents believe that GMOs have the potential of reducing pesticide and herbicide use, providing better nutrition by increasing the nutritional content of crops, improving crop yields to feed a rapidly growing world population, promoting market competitiveness, and overcoming environmental conditions such as drought and heat.



Figure 1 Production of genetically modified cotton

In case of pharmaceuticals, the use of the vaccinia-rabies vaccine, a GMO derived from

vaccinia and rabies viruses, successfully eliminated rabies (14). Genetically modified cows are a promising solution to the large-scale production of therapeutic proteins because they can be modified to express a specific protein into a frequently occurring biological process, such as milk production (15). This cow have been modified to express a protein in their mammary glands, can churn out gallons of protein rich milk more efficiently for a longer period of time.

### Ethical Issues

Are we blurring the lines between species by creating new genetically modified individuals? While the issue of the morality of crossing species boundaries reflects differing world views and may be conceptually unclear, there are known risks associated with xeno-transplantation of genetically modified cells or organs from animals to humans (16). Similarly, by combining animal DNA and human DNA with plant DNA, do we run the risk of creating new diseases for which there is no treatment? It may leads to any disaster on the earth (17).

### Conclusion

Genetic modification is the alteration of an organism's genetic makeup by introducing another organism's genes into the original organisms DNA, so that the organism will produce an enzyme or protein or even antibiotic. But to go beyond the laws of nature may reflect the new adversity on the earth. Thus, GMOs has both positive and negative side of the coin.

### References

- [1] Heylighen F, Campbell DT (1995). Selection of Organization at the Social Level: obstacles and facilitators of metasystem transitions. *World Futures: the Journal of General Evolution*. 45: 181-212.
- [2] Whitcomb EA, Taylor A (2009). Ubiquitin control of S phase: a new role for the ubiquitin conjugating enzyme, UbcH7. *Cell Division*. doi:10.1186/1747-1028-4-17.
- [3] Bastians H, Topper LM, Gorbsky GL, Ruderman JV (1999). Cell cycle-regulated proteolysis of mitotic target proteins. *Mol Biol of the Cell*. 10: 3927-3941.
- [4] Ermolli M, Fantozzi A, Marini M, Scotti D, Balla B, Hoffmann S, Querci M, Paoletti C, Van den Eede G (2006). Food safety: screening tests used to detect and quantify GMO proteins. *Accred Qual Assur* 11: 55–57
- [5] Ghisleri LR, Fresno A (2008). Spanish Competent Authority experience in the evaluation of GMO files in collaboration with EFSA. *J. Verbr. Lebensm.* 3 Supplement 2: 60 – 61. DOI 10.1007/s00003-009-0419-z.
- [6] Grohmann L (2008). GMO Detection Methodology. *J. Verbr. Lebensm.* 3 Supplement 2: 42. DOI 10.1007/s00003-009-0409-1.
- [7] Issues Surrounding Genetically Modified (GM) Products by Subhuti Dharmananda, Ph.D., Director, Institute for Traditional Medicine, Portland, Oregon, <http://www.itmonline.org/arts/gmo.htm>
- [8] Yan W, Shi W, Li B, Zhang M (2007). Overexpression of a Foreign Bt Gene in Cotton Affects the Low-Molecular-Weight Components in Root Exudates. *Pedosphere*. 17 (3): 324-330.
- [9] Blume YB (2000). Key Issues for Ukrainian Acceptance of Genetically Modified Plants and Comparison with Other Central and Eastern European Countries, in Proc. of the 6th Intl. Symp. The Biosafety of Genetically Modified Organisms (July 8–13, 2000, Saskatoon, Canada), Fairbairn, C., Scoles, G. McHughen, A., Eds., Univ. of Saskatchewan: Univ. Extension Press, 2000, pp. 15–20.
- [10] Achon MA, Alonso-Dueñas N (2009). Impact of 9 years of Bt-maize cultivation on the distribution of maize viruses. *Transgenic Research*. 18 (3): 387-397.
- [11] Ferry N, Mulligan EA, Majerus MEN, Gatehouse AMR (2007). Biotrophic and tritrophic effects of Bt Cry3A transgenic potato on beneficial, non-target, beetles. *Transgenic Research*. 16 (6) 795-812.
- [12] Capecchi MR, Evans MJ, Smithies O (2007). They were declared laureates of the 2007 Nobel Prize in Physiology or Medicine for their work on "principles for introducing specific gene modifications in mice by the use of embryonic stem cells", or gene targeting.

- [13] Ya BB (2007). The International Symposium “Biosafety Issues in Implementation of GMO: New Research Approaches, Regulation, and Public Perception” and Its Appeal in Support of the Development of Agricultural Biotechnology. *Cytology and Genetics*. 41 (3): 137–141.
- [14] Val GI (2006). Whither Agbiotechnology? *Nature Bio-technol.* 24 (3): 274–276.
- [15] Wells D (2004). Cloning and Transgenic Technology to Produce Genetically Enhanced Dairy Cattle in the Future. *Reproductive Technologies Group 2003*. 27 March 2004.
- [16] Kiss J (2008). GMO long-term effects: Relevance of environmental risk assessment. *J. Verbr. Lebensm.* 3 Supplement 2: 45. DOI 10.1007/s00003-009-0412-6.
- [17] Finck M, Seitz H, Beismann H (2006). Concepts for General Surveillance: VDI Proposals Standardisation and Harmonisation in the Field of GMO-Monitoring. *J. Verbr. Lebensm.* 1 Supplement 1: 11–14. DOI 10.1007/s00003-006-0062-x.
- 
- 

## Cartoon for Communicating Science – An Emerging Trend

<sup>1</sup>A. Ray and <sup>2</sup>A. Dutta

<sup>1</sup>Dept. of Communication and Journalism, Gauhati University-14, Guwahati, INDIA

<sup>2</sup>School of Professional Studies,

K. K. Handique State Open University, Dispur, Guwahati-6, Assam, INDIA

ankurandutta@yahoo.co.in,

anamikadady@rediffmail.com

### Introduction

When the trace of living existence has been identified, from that very moment the man tries to discover the reality. Indeed, to accomplish a comfortable life, man continuously embarks upon the challenges from nature- the origin of science. Man has discovered fire. We know all about the Stone Age, Iron Age, Bronze Age etc. We are familiar about the evolution of cultivation process, process of weaving and cooking food etc. So it is well proved that knowledge on science is necessary for human being sustainable development and for this mass awareness on science is necessary for all total society development as the history depicts. But the real portrayed is quite different. Science awareness is not reaching to the general people and so it has become incapable to achieve its basic purpose of human life. Science still remains an unfamiliar and alien area for common people due to lacking of attractive, lucid and catchy presentation to non-experts by the experts.

Science communication is facing various problems as chatting capability, mass accessibility, cultural like-minded, linguistic and socio-cultural variety, socio-political obstacles, proper process of communicating science successfully and professionally and inculcating scientific temper among the people etc. Only that science messages should be communicated, which is confirmed, genuine, tested, verified and true. Authenticity of the scientific knowledge is must for science communication because wrong, incorrect, untrue, unauthentic information may give rise terrible situation.

On the other hand it is extremely necessary to bring a change in the attitude of the general mass from the non-scientific to the scientific one and



to motivate them living in a scientific life. Science communication means to acquaint the masses with scientific knowledge for scientific awareness. All the arguments come to end when society mirrors a wide gap between scientific community and common mass, which needs to be bridged. To get rid of centuries old misbeliefs and superstitions and accomplish a familiar platform for science for mass, regional network and languages are very significant at grass root level. In science communication those 'science' is communicated which is common for all with the concept 'science should be enjoyed by all'.

Along with the other competent modern and traditional-folk media for science communication, it cannot be denied that effective potentiality of cartoon can make people enjoy science as well as easily can make them grasped the scientific temperament beyond the age bar.

### **Significance of the study**

Science communication does not only mean to include the word 'science' as the contents. Talk 'about science' not 'on science' is a general tendency which should never be devoid of scientific contents. The very basic method of science communication means explaining common science 'how and why'. Nobody enjoys science unless it is linked with the linguistic stuff of cuts and curls, covered with surprising and genuine facts, and flavoured with piquant instance through vivacious presentation. So there is awful necessity for dissemination of science sense among the common masses. But selection of the right medium, format, style and language for science communication is very important task considering human background, sentiment, curiosity and amusement.

It won't be untrue to say that cartoon is very emerging, very fun orientated and attractive medium for all section and for all age groups. Not only that, it has a direct influence. The colloquial dialects, the familiar format, context and content of the media give much clarity in communication. It is so flexible that any science message or themes can be accommodated in them for inculcating scientific temperament.

### **Objective**

1. To analyze the impact of cartoon on general masses in communicating science.
2. To explain the evolution of cartoon and scientoon.
3. To scrutiny the job prospects of cartoon in science communication especially in Assam
4. To study the initiatives taken in the field in Assam.
5. To investigate the procedure of on hands training on cartoon in terms of science communication at grass root level people.

### **Research Methodology**

Qualitative method has been employed. To collect the primary data, we followed interview & observation, case study method. For collecting the required information to complete the work we have contacted and taken help a few relevant sources. Keeping in view the complexities of social customs, cultural norms and values of the villagers, we specially have given stress on informal interview.

For secondary sources we tried to explore a few web sources and books. At last we went for a hands on training in village on cartoon drawing by a group of Guahati University. There we tried to get feed back and tried to assess the impact and effectiveness of this particular medium.

### **Discussion**

The field work mirrors a few very important data. On that basis the discussion may be started. According to that cartoon is one of the best media for communicating science to the general people and is now fast becoming an admired device to popular scientific thinking around the globe. It is popularly used as a drawing depicting a humorous situation, often accompanied by a caption or a drawing representing current public figures or issues symbolically and often satirically. [1]

At the very outset let us discuss on the meaning of cartoon. Actually, cartoon is a form of illustration with varied meanings and imagination. The term has evolved from its original meaning from the fine art of the late middle ages and renaissance. It is a combination of caricature i.e. funny drawing and satire i.e. funny saying. A caricature is the distorted

presentation of a person, type or action, which looks funny. Cartoons were typically used in the production of frescoes, to accurately link the component parts of the composition when painted onto plaster over a series of days. Such cartoons often have pinpricks along the outlines of the design, a bag of soot was then rubbed over the cartoon, held against the wall to leave black dots on the plaster. Cartoons by painters such as Raphael and examples by Leonardo da Vinci are highly prized in their own right. A monthly sheet of caricature began publishing in London in 1830. Famous cartoon magazine Punch got started publishing in 1841 while another such magazine College Humour was published in 1920s and 1930s. New Yorker began publishing in 1925. In this way cartoons become a very popular medium of effective communication. Gradually, cartoons were used by some thinkers to communicate or disseminate the complex part of science to the general mass and 'scientoon' came to the screen [2].

### Impact cartoon

At the late nineteenth century, cartoons have been usually featured as regular typical characters, and contained either a complete story or a series of episodes. The history says that *The Yellow Kid* (1895, with words on the shirt of "the Kid") was the first to regularly employ text. [3] The Yellow Kid was created by Richard F. Outcault. A bald headed, toothless, grinning kid, dressed in a yellow sack-like garment made the history in its own. This character depicted life in the slums of New York which was able to achieve extreme popularity [4]

One of the comic pioneers Richard Felton Outcault (14/11863 - 25/9/1928, USA) was the inventor of the comic strip. Outcault was graduated from the McMicken University in Cincinnati and settled in New York. The *Electrical World*, *Life* and *Judge* are some illustration work for publications. Praising his performance media tycoon Joseph Pulitzer offered to work for the *New York World* in 1894, for which he concocted a series of cartoons set in certain quarters in Manhattan, which eventually resulted in the feature 'Down in Hogan's Alley'. It raised the circulation of his newspaper called *Sunday World* in New York. Then using yellow ink in colour printing was rare because it didn't dry properly. When one of the

World's foremen of the colour-press room wanted to experiment with a new type of yellow ink, he used the shirt of one of Outcault's characters as a test area. 'The Yellow Kid' was born.



The Yellow Kid was at the zenith of success. The character and its creator also became a pivot in the newspaper battle between tycoons Pulitzer and William Randolph Hearst. With two rival 'Yellow Kids' appearing in the two newspapers, a new phrase in the American newspaper vernacular was born i.e. "yellow journalism". Around 1901 'Lil' Mose', the first strip with a black as its principal character (in James Gordon Bennett's *New York Herald*), in 1902, 'Buster Brown', another classic including a popular line of kid's shoe which is being used to advertise for cigars and whiskey, 'Buster Brown' until 1921, 'Tommy Dodd' and 'Aunt Ophelia' in the *New York Herald* (1904), as well as 'Buddy Tucker', featuring a side-character from 'Buster Brown' were a few Outcault continue creations[5].

Cartoons have the rare ability to say or express serious issues in a light hearted manner. So, anything of importance can be treated with both seriousness and a dash of humour added to it, which would have a universal appeal. The very fact that it can appeal to all ages and in any parts of the world without creating any offence to anybody is a gift in itself. Thus, having a greater reach and accessibility by the people, the rate of its success definitely goes higher.

The civic relevance between a cartoon and a comic is very simple. A cartoon is an animated visual format with sound and a comic is a written, printed format in black and white or colour. Some characters appear in multiple formats, having an animated series on TV, movie or comic strip. Characters from *Peanuts*, *Cats*, *Felix* and *Garfield*, *Mickey Mouse*, *Donald Duck* and a host of *Walt Disney* and *Walter Lantz* are some examples. Other characters may appear in only one format such as in many video games

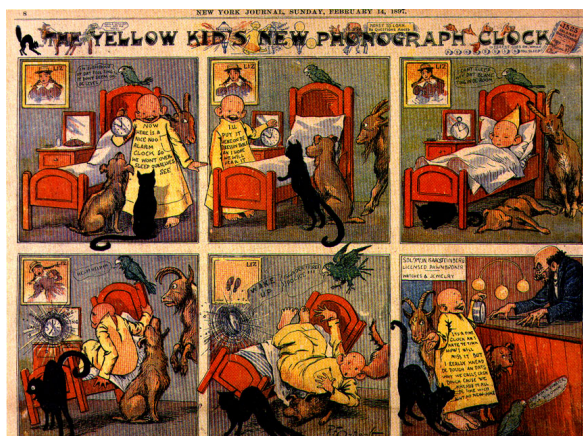
which is yet another venue. Cartoonists may work in many different formats as single panel gag cartoons, editorial cartoons, comic strips, comic books, graphic novels, or animation [8]. Animation is a film technique in which film makers create the illusion of motion, rather than recording it with a camera as live action. In making an animated film, a filmmaker photographs a series of drawings or objects one by one. Each drawing makes up one frame of the film. When the film is shown through a projector, the subjects appear to move. Animation is most popular in creating cartoon films. Advertisers may also employ animation techniques to advertise their products on television. In addition, producers of instructional films may use some kinds of animation to help explain a difficult idea or an idea that could not be shown in live action. Animation can also be combined with live action in a film [9].



[10]



[11]



'The Yellow Kid'[6]

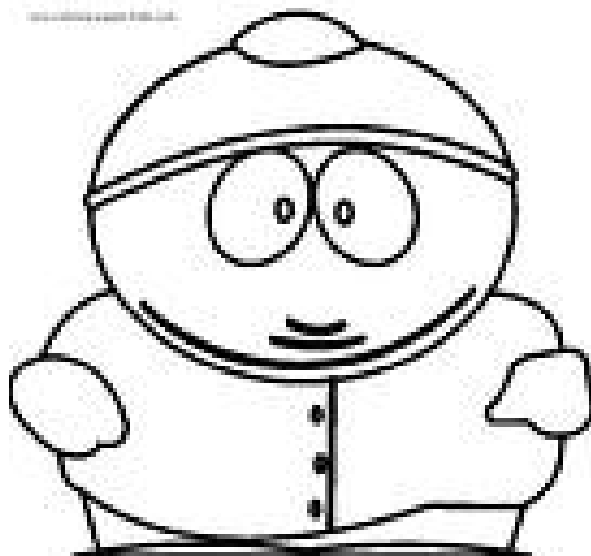
Here we can have some example of popular cartoon character. Disney (The famous dialogue: "I can do it") has an impact on children. The Lion King: I may be little, but I am strong is very popular also.



Mickey Mouse in Steamboat [12]

The Simpsons and south park are the main satirical cartoons that impact our culture [13]

The whole world in cartoon is presented in certain way that automatically impresses our mind. The cartoons are based on different themes like fighting, jumping, kicking, killing etc. Normally when we see this we enjoy it a lot. For example-when Jerry is fighting with Tom is well liked. We like Spiderman who can jump from here and there, and also climb any high wall. The kids grow a tendency to be Jerry, a Superman. So it has been established that cartoon character can reach to our heart very easily. Science being dreaded by some people thinking that its not a subject for the general masses, could be simplified through the use cartoons.



The science trough cartoon can be recognized as scientoon. Scientoons are a novel class of science cartoons that not only makes some one laugh but also carry some scientific information, message while attracting one's attention towards a problem in a thought provoking way. Scientoons have revolutionized the way through which science can be communicated by making complex and highly technical science subjects very simple and easily understandable. It is undoubtedly a great contribution towards communicating science by making it understandable and enjoyable to common man and experts alike[17].



[14]



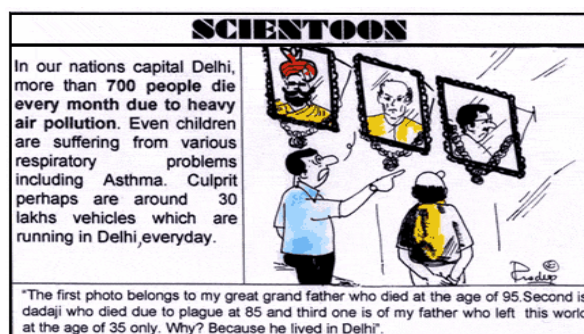
[15]



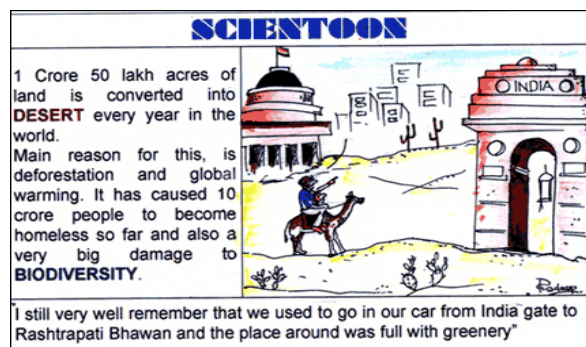
[16]

### The concept of Scientoons

The term 'scientoon' was coined by an Indian scientist and artist as well, Dr Pradeep Srivastava, a scientist from the Central Drug Research Institute (CDRI), in 1988, while delivering a lecture on the topic 'Development of drugs and pharmaceutical industry in developing countries' in a conference held at the National University of Singapore. The Royal Swedish Academy and Swedish National Committee for Science and Technology, which organized the 32nd International Union of Pure and Applied Chemistry Congress in 1989 at Stockholm, Sweden, accepted a research paper entitled Scientoon for presentation at the congress. This paper explained how scientoons can be used to educate the people about the various rules and phenomena of chemistry [18].



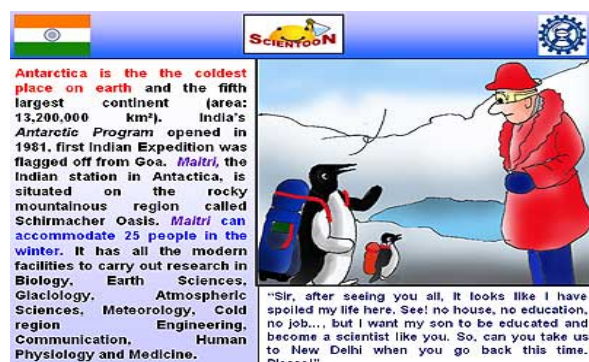
The presentation Deforestation & Global Warming through scientoons [21]



The presentation Species in Danger: Indian Cheetah through scientoons [22]



The presentation climate change through scientoons [23]



Scientoon in Assam [24]

From 1990, Dr Srivastava started using scientoons for explaining and highlighting various environmental issues, concepts and problems. The United Nations Environment Programme published a report on this novel approach in its Asia-Pacific Newsletter. In 1993, this Indian scientist chose an important analytical technique, 'mass spectroscopy' for delivering lectures using scientoons. This was a unique attempt to explain a highly technical subject in a very simple and interesting manner through scientoons. Incidentally, scientoons is the branch of science based on cartoons providing information about the latest researches, subjects, concepts and data through wit and humour in a simple, understandable and interesting way [19].

The presentation Air Pollution in Delhi through scientoons [20]

Cartoon is a language of miracle showing with enormous strength to convey thoughts. It is able to express at a glance the most acute and brief messages, combining the best coalition among form, context and content. The cartoon is vector of information, commentator, critic, discloser of conscience. In these days of dangerous globalization, the cartoon is the language of the better future which can be considered to cement of our changing civilization<sup>24</sup>. As a powerful medium of visual communication comics cross all borders of language and creed. Cartoon can help in working for the environment, women's issues, population, HIV/AIDS, peace and human rights and other civic science issues [25].

In Assam there is a regular use of cartoon in different media with different context. Basically it is usually seen in political context. But Bigyan Jeuti, Prantic like magazine have pioneered cartoon for science. Late Dost Habibur Rahman (famous parody singer) was the first person to draw scientoon in Assam (in Bigyan Jeuti, late 60s). After that Khiradhar Baruah, the veteran science communicator and National

award winner in science communication field extended his contribution for in Bigyan Jeuti in this regard.

In the modern days though the cartoon is in the great hype, the cartoonist who are working for science popularization is really in less number. In Assam, one or two persons seldom do science cartoon which is negligible to consider. The young cartoonist Sumanta Baruah of Assam is having an endless effort in the promotion of science through cartoon and comics. His creation has been able to take place in many magazines and journals like Science Reporter [NISCAIR(CSIR), New Delhi], Resonance (Indian Academy of Sciences, IISc, Bangalore), Bigyan Jeuti (Assam Science Society, Guwahati), Drishti (Edited & published by Dr. D.C.Goswami on behalf of Govt. of Assam), Satsori (Pratidin House, Guwahati), Journal of Assam Science Society (Assam Science Society), Prantik (Guwahati, Assam). This young chap's cartoons have been exhibited in 3rd Rhodes International Cartoon Exhibition, Greece (2006) and in International Cartoon Festival, Iran (2006). 'Science Shapes Life' is a book by him which is a compilation of his selected cartoons published by the Assam chapter of Indian Science Writers' Association.



"Sir by mistake you have given the assurance of bringing rain instead of proper irrigation" [27]



"My dear friend, we will be saved if the future generation does not blame us that we started the concept 'pollution'" [28]

### Employment scope in cartoon

The avenues in the scope of cartoons are increasing with the advancement in technology. Today Animation as a career is a much in demand sector. Apart from good artists being employed in various print media houses as cartoonists, people having a knack in drawing can also find themselves being involved in the fields of Advertising, NGO's, Grassroots Comic activist, Animation sector, Web designer, etc.



"The evolution of *Homo sapiens*" - celebration of the Darwin birth ceremony [29]



I agree they are using e books, audio books etc. Can't you rejoice with me because I am saved? [30]



Aren't those tearing drops between her sweat drops? [31]

One who is having ingenuity, artistic skills, panache of sketching, ardour, hallucination skills, sense of colours, steadiness and devotion for in work for him it is a rewarding career in animation Industry. XII standard qualification for diploma or degree and graduation level for post graduation diploma/degree is needed in animation. After that the person can work as a professional animator, modeller, layout artist, scanner operator, key frame animator, compositor, graphic designer, content writer, web designer, etc in various film productions centres, TV channels and studios, business houses, educational institutes, publishing house, medical/legal/insurance industry for presentation and models, defence (virtual reality), advertising world (ads and commercials), fashion industry, etc. There are various professional courses that one can study like advanced diploma in digital visual communication and animation, diploma in rotoscoping, traditional and stop-motion animation, 3-D/2-D animation, human anatomy, drawing, Interactive multimedia, web authoring, film animation, etc. These courses focus on training with latest techniques of animation world. 'In a recent report, NASSCOM, the apex body of IT software and services, makes it clear

that although growth has been limited by the current economic downturn, growth in the industry is still strong with the animation and gaming industries in India projected to grow at annual rates of 22 and 49 percent respectively during the next few years to 2012. The report also states that currently 15,000 people work in animation and gaming in India and the demand in the same number lies till the next four years'. Many private and public institutes offer courses in animation in various parts of India like NID, Ahmadabad [www.nid.edu], IIT Mumbai and Guwahati, Zee Institutes of Creative Arts [www.zica.org], Arena Multimedia [www.arena-multimedia.com], Indian Academy of Digital Arts & Science, Pune [www.iadasanimationworld.com], Institute of Gaming & Animation, Pune, Maya Academy of Advanced Cinematics [www.maacindia.com], BITS, Ranchi [www.bitmesra.ac.in] [32].

### The procedure of hands on Training in Cartoon

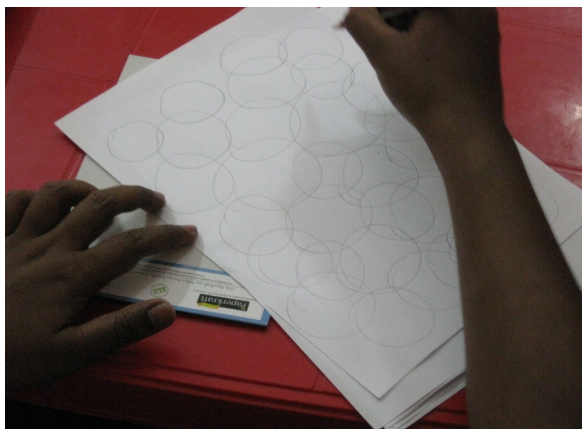
The cartoon may be popularizing among the general people of a society to inculcate the scientific temperament. In a few festivals (Bihu, Silpi Divas, Rabha Divas etc) of Assam, various competitions among the children and youth like 'go as you like' (children fashion show), drawing etc. To popularize cartoon as a medium, competition may be organized.

A noteworthy initiative has been taken by the Gauhati University in this regard. The students of Mass communication of the University have formed a group named 'Grassroot comics' to popularize the medium among the grassroots people. The members of this group were trained by the World Comics India. World Comics India (WCI), which is an accumulation of artists, media persons, social activists and grassroots people formed in June 2002. It has also worked in collaboration with World Comics Finland, which has worked in various African and Latin American countries. WCI emerged from an extensive diversity of backdrops to create a social movement that recognizes comics as a powerful tool for social transformation. Numerous grassroots activists and people with little formal training in illustration and story writing have been able to use comics to express their thoughts in their own way.

Encouraged by this noble approach of WCI, the Grassroot Comics has started to train the grass root people of the society to draw cartoon in a lucid way to conglomerate their thoughts-sentiments-aspiration- grievances through cartoon. The group already has organized a few such workshops in remote villages of Kamrup District, Assam. Among them workshops in collaboration with NGOs like Mushroom Development Foundation (MDF) to train villagers of Sonapur in mushroom cultivation, in association with the Voluntary Health Association of Assam (VHAA) to prepare comics against the ill-effects of tobacco followed by comics display in public places like schools, colleges, the zoo and Gauhati University, training programmes for school students and children of shelter homes, workshop for Guwahati University students etc. [33]. Comics are produced in different formats – wall poster comics, printed wall posters, booklets and strips. This genre of communication concentrates on story than art. As every human can draw, he can easily draw rough caricatures which would be polished by comic trainers. One such group, 'New Ways' strives to promote this new medium in Assam [34]. The training needs three full days. The work plan of the training days is as follows.

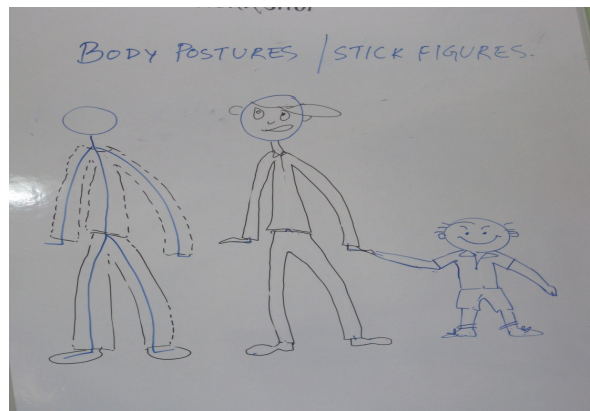
#### Day 1

- Introduction of the trainers and the concept of cartoons through face to face communication.
- The participants are asked for Free hand drawings.
- Different facial expressions by manipulating the letter O and T are taught.
- Then they are asked to accessorize them by putting hairstyles, beard, glasses, etc.



- Explaining the concept of a story: Making the participants aware of the difference between an essay and a story. Explaining to them the importance of Theme, Focus, Sequence of Events, importance of Drama, Message and Target Group while writing a story. Civic science message are told to be incorporated.
- The story is split into four parts.
- Story writing session with a group analysis is carried out.

#### Day 2



- Drawing exercises: The participants are asked to undertake drawing exercises on BODY POSTURES by starting with stick figures then moving to flesh and clothes. Then different body postures could be tried out by a trainer posing for the participants.
- Cartoons grammar: The participants are explained the various details pertaining to the technical aspect of making a comic. Things like the use of different Speech Balloons, Readability, etc. are explained to the participants.
- Visual Scripts: The participants are asked to work on the visual scripts and make rough



drawings by dividing their story into four halves and putting in the dialogues on their illustrations.



- Margins and Inking: The margins are given and inking is taught after which the participants start working on their final art work.
- Heading or Title: An appropriate title or heading which is attractive enough and does not give out many details about the story is sought and put on the comic.

### Day 3

- Critique Session: A critique session is undertaken by putting up all the comics made by the participants and a round of critical appreciation is done with a bid to highlight the good points in a comic as well as discuss the lacuna. This session is done to boost the confidence of the participants and make the realized about the basic needs of the scientific temperament.



**Field Testing:** Field testing is an important attribute of the workshop as it is only in a field where the real success of a medium can be gauged. Usually the fields are chosen based on factors like the availability of target audience if it is theme based, because it will be best received if the medium reaches to the desired target group. It is done in places like market areas, schools, colleges, movie halls, etc. Feedbacks are taken from the audience which serves as an important tool to assess its success.



### Feedback procedure

- The feedbacks are received during the field testing done at the end of the workshop. In fact the field testing session is the crux of the whole workshop as it is there where the actual success of the medium can be determined. The cartoons after completion are taken to the field and showed to the people, they are explained about the concept and asked to read the cartoons. The answers from the respondent are the measurement of the effectiveness of the medium.
- On the other hand an active group is formed among the participants. They extend their contribution through the training process of the following villages. Like wise a chain of science cartoonists is being tried to create to sustain the science sense among common people.

### Conclusion

Cartoon is taken in a humorous or unserious demeanour which has the rare ability to appeal to all categories of people. It has the capacity to express the most serious issue in a light hearted manner and nevertheless be well heard. Modern technology has no doubt revolutionized the trend

of it, but yet it strives on with its various formats at display. The essence of this media lies in fact, anyone can use it. The main goal of this medium is to provide an alternative medium to the people where the reach and access of mainstream media is negligent. The cartoons more often than not lead to a public debate or at least arouse the minds of different people and change their way of thought resulting to a positive change.

Cartoon can be duly used in communication media due to its mass appeal. And last but not the least, who wouldn't like the combination of an important piece of advice offered with a good laugh and attractive visuals. Catering to all groups of human beings, this can be a strong tool for social development and a great tool of science communication.

## Reference

- [1] 'Science though Cartoon', The Assam Tribune, Anamika Ray & Ankuran Dutta.
- [2] 'Science though Cartoon', The Assam Tribune, Anamika Ray & Ankuran Dutta.
- [3] 'Comics',  
[www.answers.com/topic/comics](http://www.answers.com/topic/comics)
- [4] Hand book of journalism and Mass communication by V.B Agarwal & V.S Gupta
- [5] 'R. F. Outcault', [lambiek.net/artists/o/outcault.htm](http://lambiek.net/artists/o/outcault.htm)
- [6] 'Yellow Kid - Hogans alley', [unit1-petegittins.blogspot.com](http://unit1-petegittins.blogspot.com)
- [7] [chnm.gmu.edu](http://chnm.gmu.edu)
- [8] <http://www.eslbase.com/articles/comics.asp>
- [9] World Book Encyclopaedia.
- [10] [disney-clipart.com/.../mickey-mouse16.php](http://disney-clipart.com/.../mickey-mouse16.php)
- [11] [disney-clipart.com/.../mickey-mouse16.php](http://disney-clipart.com/.../mickey-mouse16.php)
- [12] [homepaddock.wordpress.com](http://homepaddock.wordpress.com)
- [13] [www.coloring-pages-kids.com/coloring-pages/ca](http://www.coloring-pages-kids.com/coloring-pages/ca)
- [14] <http://shahriar08.files.wordpress.com/2008/11/2008-130-the-impact-of-the-baby-bonus.jpg>.
- [15] [tumblrquote.tumblr.com](http://tumblrquote.tumblr.com)
- [16] [spidermannews.com](http://spidermannews.com)
- [17] 'Science though Cartoon', The Assam Tribune, Anamika Ray & Ankuran Dutta.
- [18] 'Science though Cartoon', The Assam Tribune, Anamika Ray & Ankuran Dutta.
- [19] 'Science though Cartoon', The Assam Tribune, Anamika Ray & Ankuran Dutta.
- [20] <http://www.scientoon.com/>
- [21] <http://www.scientoon.com/>
- [22] <http://www.scientoon.com/>
- [23] <http://www.scientoon.com/>
- [24] [http://www.worldpresscartoon.com/temp/late\\_3c.php?year=2009&jury=1213](http://www.worldpresscartoon.com/temp/late_3c.php?year=2009&jury=1213)
- [25] [worldcomicsindia.com](http://worldcomicsindia.com)
- [26] [www.cartooncosmos.com](http://www.cartooncosmos.com)
- [27] [www.cartooncosmos.com](http://www.cartooncosmos.com)
- [28] [www.cartooncosmos.com](http://www.cartooncosmos.com)
- [29] [www.cartooncosmos.com](http://www.cartooncosmos.com)
- [30] [www.cartooncosmos.com](http://www.cartooncosmos.com)
- [31] [www.cartooncosmos.com](http://www.cartooncosmos.com)
- [32] 'Science though Cartoon', The Assam Tribune, Anamika Ray & Ankuran Dutta, Sept 20, 2009.
- [33] 'Comic for Change', [www.assamtribune.com/oct0409/sunday1.html](http://www.assamtribune.com/oct0409/sunday1.html), Oct 4, 2009
- [34] 'Comic for Change', [www.assamtribune.com/oct0409/sunday1.html](http://www.assamtribune.com/oct0409/sunday1.html), Oct 4, 2009

## Environmental Interpretation in Forest Urban in PUC Minas

A.C. Sanches-Diniz<sup>1</sup>, L.P. da Rocha  
Afonso<sup>2</sup> and J.A. Leite-Dutra<sup>3</sup>  
Museu de Ciências Naturais PUC Minas, Av.  
Dom José Gaspar, 290, Bairro Coração  
Eucarístico. Belo Horizonte, Minas Gerais,  
BRASIL

<sup>1</sup>anacsdiniz@yahoo.com.br;

<sup>2</sup>jesicaalves\_15@yahoo.com.br,

<sup>3</sup>lidiabio2011@yahoo.com.br

**Abstract.** The environmental interpretation in natural areas leads to reflections, giving each participant to review its stance in the face of natural environments. For the people of urban centres, the tracks provide diversification of routine work, study and wasted. The interpretation of the Trail Bem-Te-Vi in urban forest in Belo Horizonte, Minas Gerais, Brazil has been contributing as an alternative method of contact with nature in the big cities combining content hands-on activities, the interpretation is developed in an attractive, provocative and enjoyable with the various profiles of public.

**Keywords:** environmental interpretation, conservation, educational practices, track, urban forest.

### 1. Introduction

The learning with play contact with the natural environment presents us the opportunity to break with ways to feel, think and drive our actions, with values sedimented by a routine that keeps us regarding our animal / natural: intuition, instinct, ability to deal with the unexpected, it all lost the daily urban environment. And being in nature breaks the force, negotiations and confrontations that lead to the construction of new readings on ourselves, our joys, our beliefs about who we are what we like and what we believe. (Cassino, 1998).

The Earth gives clear signs of exhaustion due to the adverse impacts caused by human society that has been causing disharmony in nature, affecting the current quality of life and significantly compromising the survival of future generations.

Everyone must know that each one, each citizen is part of the whole and individual attitudes directly affect the environment and land that make up this planet a larger system that also interacts with other systems... Environmental education comes to rescue the positive relationship between man, nature and the universe, helping to develop an ethical awareness of all forms of life with whom we share this planet.

The consumer society needs to change their concepts about the nature, interacting with the environment positively and not just exploratory.

The taste for hiking and exploration in natural refuges always existed and people sought for this purpose trails in natural refuges. The groups were usually led by natives, local people, familiar with the route, pointing curiosities. These activities served as the basis for what is now called the Environmental Interpretation.

The term interpretation of the nature or environmental interpretation refers to a set of principles and techniques to encourage people to understand the environment by practical experience merge.

The basic goal of environmental interpretation is to reveal the meanings, relationships or natural phenomena through practical experience and means of interpretation, instead of a simple statement of facts and figures. (TILDEN, 1967).

The environmental interpretation includes the translation of technical language of a natural science to be understood by people in general, so interesting for the listener. (HAM, 1992)

The objectives of the Environmental Interpretation are to facilitate the knowledge of nature in order to conserve its natural resources, historical and cultural, to achieve the satisfaction of visitors, adding value to the visitor experience, show the need for heritage conservation visited.

The visitor satisfaction is directly related to the new. The more you learn new things, his greatest satisfaction.

Thus, the form of mediation of content must be well done. Interpretations should be more provocative than explanatory, arousing curiosity in the participants, avoiding the implementation of content in long exposures. The visitor must be an active rather than passive.

The interpretation is characterized by informality and charm, the provocation stimulus, curiosity and reflection and the use of

interactions, comparisons and analogies with real life experiences, covering topics relevant aspects often overlooked and / or seemingly insignificant.

Initiatives to environmental interpretation in forests are extremely important in process of changing paradigms, review, recovery and reversal of values, because the approach to environmental issues leads to reflections, giving each participant to review their posture facing the environment natural.

For residents of urban centres, trails in natural environments, may have the role of psychological recovery and diversification of activities, offering something different from the routine of work, study and consumption, promoting a closer relationship with nature.

Often the lack of alternatives is that prevents this approach and, according Boo, 1992, Takahashi, 1998, “this fact makes the demand for natural areas increase, especially among urban populations, who are seeking more contact with nature”.

People in cities do not have money or time to go to remote forests, in this way the interpretive activities in urban forests are an alternative to more contact with nature for these people.

Tilden, 1977, in his book “Interpreting Our Heritage”, underscores the importance of direct contact with the elements that are being interpreted through practical activities, in order to give participants a real ownership of the content and inserting each as part of the whole.

The area of this work, the "Forest of the PUC," is a fragment of 10 ha of seasonal semideciduous vegetation (plants lose some of their leaves during the dry season), inserted in a residential area and isolated from any other type of vegetation (Figure 1).

This urban area has a good diversity of flora and fauna, habitat of several species of invertebrates and reptiles, with two species of mammals recorded, the possum-eared white (*Didelphis albiventris*) and the marmoset (*Callithrix penicillata*). The greatest diversity of species is the birdlife, as well-te-vi, soul-to-cat, and toucans, among others. The native vegetation is well preserved, with species such as cedar, alligator-wood, jatoba...



Figura 1 – Vista área da “Mata da PUC”

The forest of the PUC is frequently visited by students, such as access to campus officials. The forest is also frequented by school students and public visitors, led by educators, as complement the activities of the Education Program of the Museum of Natural Sciences PUC Minas.

## 2. Methodology

The idea of environmental interpretation at the PUC Mata came up with bibliographic research on interpretation and environmental education and the need to improve the educational activities developed in the local tracks.

Then began the project "Implementation of the Forest Interpretive Trails PUC Minas, Campus Eucharistic Heart," which began in February 2009, with the main objective to plan and prepare scripts for interpreting the tracks of the Mata da PUC Minas.

There are several types of audiences that visit the Museum PUC Minas suggesting the construction of interpretative activities differentiated to meet children and adults, teachers and students, the elderly and disabled.

In the first stage of the project, which gave her between February and May 2009, the path chosen for implementation of the Interpretation was already used by educators in the museum activities, from then on called "Trail Bem-Te-Vi" due to the constant presence of this bird throughout the route.

Were defined themes and stopping points for organizing the work of educators. This paper describes the techniques, phrases and educational

material for interpretation, such as plates, replicas and choice of natural elements to touch.

The proposal also includes ongoing evaluation of activities through questionnaires at the end of the trail, beyond the analysis of perceptions of visitors and educators.

There are many initiatives by the museum educators, to promote lectures, trail rides and other recreational or educational activities that result in better informed and well-being for visitors. However not all of these activities can be classified as Environmental Interpretation. These activities can be considered techniques and instruments that make up the approach of Environmental Interpretation.

The process of interpretation begins in 1957 with the philosopher Freeman Tilden, which considers the interpretation "educational activities, it disseminates meanings and inter-relations through the use of original objects, direct contact with the resource and the ways illustrative rather than simply communicate the literal information."

Thousands of naturalist, historians, archaeologists and specialists are engaged in the work of revealing, to such visitors as desire the service, something of the beauty and wonder, the inspiration and spiritual meaning that lie behind what the visitor can with his senses perceive. This function of the custodians of our treasures is called Interpretation. (Tilden 1977: 10)

1. Any interpretation that does not somehow relate what is being displayed or described to something within the personality or experience of the visitor will be sterile.

2. Information, as such, is not interpretation. Interpretation is revelation based upon information. But they are entirely different things. However all interpretation includes information.

3. Interpretation is an art which combines many arts, whether the materials presented are scientific, historical or architectural. Any art is in some degree teachable.

4. The chief aim of interpretation is not instruction, but provocation.

5. Interpretation should aim to present a whole rather than a part, and must address itself to the whole man rather than any phase.

6. Interpretation addressed to children (say, up to the age of twelve) should not be a dilution of the presentation to adults, but should follow a

fundamentally different approach. To be at its best it will require a separate programme.

Tilden (1977:9)

To maintain interest and attention, information needs to be presented in interesting and stimulating ways. Interpretation which is boring and monotonous, difficult to read, listen to or work out is not likely to attract much attention or hold an audience for long.

Sam Ham (1992) defines the qualities of effective communication as the PEROT principle. That is Enjoyable, Relevant, Organised and Thematic.

In "Manual de Introdução à Interpretação Ambiental" – Projeto Doces Matas – Minas Gerais (IEF/IBAMA/Fund Biodiversitas/GTZ. Outubro de 2002), "Environmental Interpretation is meaningful, relevant or irrelevant when we are able to relate its contents with something we already know or experience... because the information passing through our list of experiences and personal experiences, so finding, meaning."

"Humans as a species instinctively pay greater attention to differences and changes. Any repetition will quickly lose visitor attention, and without attention it is difficult to create successful communication."

Moscardo (1999:28)

In a provocative interpretation the interpreter invites visitors to reflect, ask questions and allows the theories are developed by the visitor, from their observations and perceptions.

"To be at its best it will require a separate programme." (Tilden1977)

The "identity" of the interpretation is provided by the main message, according to some authors, is the main feature for an interpretation of good quality.

Studies on the capacity of the human shows that only five to nine ideas are treated at the same time, yet the ideas follow a logical sequence. For an interpretation organized, "there must be a beginning, middle and end."

"The interpreter must prepare a presentation so that visitors can distinguish easily the main points."

"The interpretation should be interesting, pleasant, charming, hold public attention and entertain you. The media used must provide a non-formal atmosphere." (Projeto Doces Matas – Manual de Introdução à Interpretação Ambiental. Minas Gerais, 2002)

The process for conducting an environmental interpretation of quality depends greatly on the interpreter and the way they communicate with the public. Some factors may compromise the quality of interpretation, such as reporting isolated, disconnected and the use of technical language, that for the general public, causes a certain distance. Moreover, the interpreter must allow freedom of the visitor, without influencing their perception, so that it (yet) has their own feelings and draw your own conclusions. The interpreter can still avoid the use of large text, with too much information, but without reducing it to undermine the content.

Below are the technical data of the Trail Bem-Te-Vi:

**Extension:** approximately 800 meters **Level of difficulty:** average time duration (with interpretative activity): approximately 1 hour. **Input:** area adjacent to the Museum PUC Minas. (Figure 2).

**Audience:** Community school, organized groups and visitors to the Museum PUC Minas in general.

Interpreting the Trail Bem-Te-Vi The topic is the general idea of the interpretative approach. The themes are the messages passed along the way, related to the topic. The topic set for interpretation of the Trail Bem-Te-Vi was the Environmental Conservation, and the themes covered are: characteristics of the fauna and flora, fauna versus local impacts (construction, deforestation, garbage), personal contributions to sustainability, sustainable activities in environmental natural.

Ways and Means interpretation techniques are the various resources used to accomplish the Environmental Interpretation. On the Trail Bem-Te-Vi were selected points, information boards and objects to touch.

**Interpretative Points:**

The visitor is invited to play in the tree (Figure 3) and observe carefully, because its trunk resembles the hull of the alligator.

The natural process of nutrient cycling is shown in an area full of dry leaves.

“What we observed in these trees is that in the winter, the leaves change colour and fall. This phenomenon is natural life of these trees. This phenomenon helps reduce loss of water during the dry period. Visitors are invited to observe the trees. (Figure 4).



Figura 2 – Entrada da Trilha Bem-Te-Vi

All are important in the vast web that is life. The web represents the links between people, which are linked both by their positive attitudes, which help in conserving the environment, as the negative, that contribute to degradation. So it becomes essential to know the consequences of human intervention in environments, so that from the acquisition of consciousness, each one takes its importance in the transformation and reconstruction of an environment conducive to all forms of life. Small acts taken together can and do make a big difference.

The web of life is a dynamic normally used with the goal of integration between teams, through the exchange of knowledge and relationships between participants and, based on this principle, several adjustments are made according to the message you want to work with the group.

The dynamic "Web of Life" was adapted to work awareness of the need for change in attitudes and habits by encouraging a more positive relationship with nature, emphasizing the cultivation of respect in general.

Participants are invited to stay in a circle and say a positive action and a negative relationship with nature. With one end of the string held in the hand, throw the roll to another participant of the wheel, at random. The next person picks up the ball and, after winding the line on one finger, will repeat the same process as the guide. And so, the activity will continue until all of the group

have been presented and described their attitudes. At the end of the activity there will be a kind of web formed inside the circle, where the wires are joined to each other. Participants perceive the interaction between all actions, both positive and negative with respect to nature. The reflection on the need for paradigm shift and attitudes is automatic at the end of the activity (Figure 5).

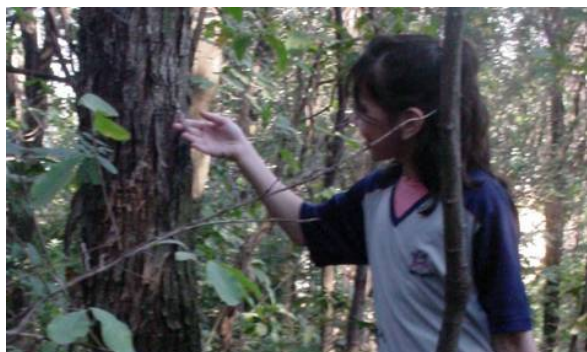


Figura 3 – The visitor is invited to play in the tree (Piptadenia gonoacantha)

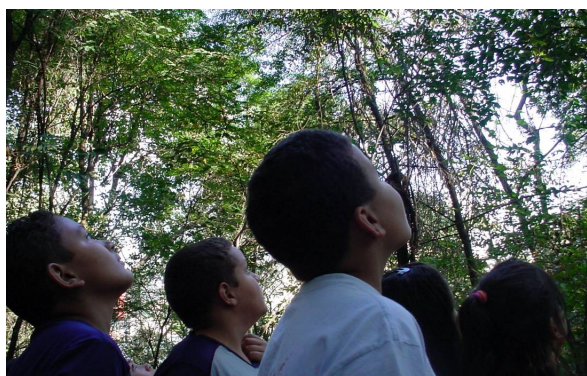


Figure 4 – Visitors are invited to observe the trees

Rappel were installed in some parts of the trail. This initiative provides plenty of adventure and fun and ends the activity with pleasure. (Figure 6).

### 3. Results and Discussion

The interpretation of the Trail Bem-Te-Vi was developed in May, June and July, with students and teachers in nursery and elementary schools, as well as spontaneous public who attend the museum, composed of families, youth and adults. Approximately 300 people visited the trail during this period.

In the July holidays the script was developed in Project Holiday at the Museum, with children of 04 and 09 years, with the presence of

characters of Brazilian culture, such as "Caipora" and "India Mayara. (Figures 7 and 8). With the help of children, the characters addressed the environmental education, collecting the garbage from the forest and saving the animals of the hunter.



Figure 5 – dynamic web of life



Figure 6 – Rappel - ending with adventure

Structures for the interpretive trail are being implemented gradually. Feeders were installed at strategic points to supply the fruit, which act as attractive to birds and the monkeys (Fig. 9).

The evaluative questionnaires were administered randomly at the end of each activity

to at least 5% of the public who developed the trail. In general the trail, even with little infrastructure, was evaluated as satisfactory by the public, as follows below:

In evaluating the dynamic "Web of Life," 92% of the public interviewed considered that it contributes to awareness. The remaining 8% thought that it does not contribute. (Diagram 1). 74% considered the trail in very good condition. (Diagram 2).

95% considered the content being used as very good, and 5% rated it as good. (Diagram 3).



Figure 9 – Feeders for birds



Figure 7 – “Índia Mayara”

Of the respondents, 92% considered that the Interpretation has been educational. (Diagram 4)

In assessing the performance of the educator, 7% marked the item "regular" 10% "good" and 83% marked "excellent". (Diagram 5).



Figure 8 – “Caipora”

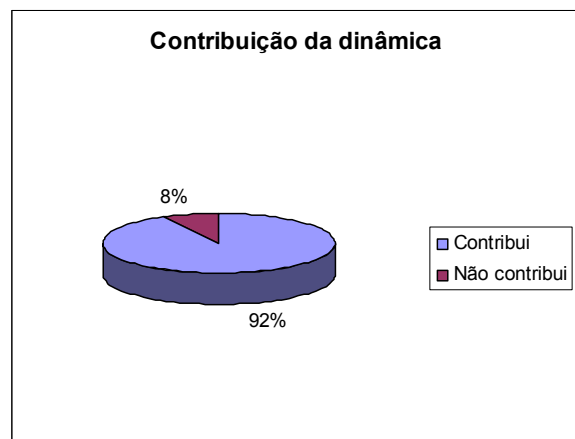


Diagram 1 – dynamic "Web of Life,"

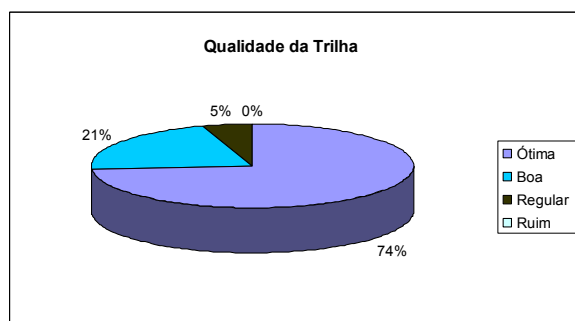
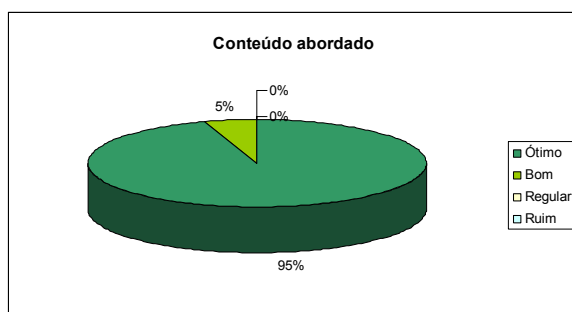


Diagram 2 – Quality trail





Graphic 3 – Quality Content

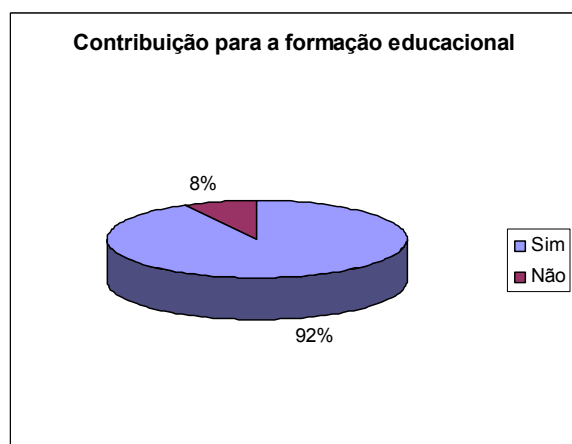


Diagram 4 – Interpretation Educational

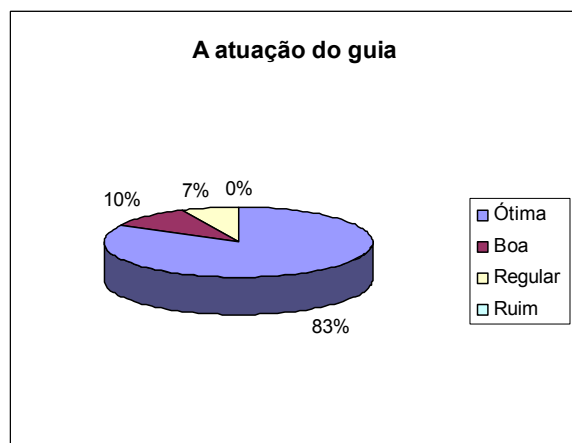


Diagram 5 – performance of the educator

The development of the draft interpretation of the Trail Bem-Te-Vi helped in Environmental Education staff, reducing impacts before observed, such as garbage and unnecessary deforestation. It also encouraged the creation of the Revitalization of the Forest of PUC (in preparation), the responsibility of the Museum of Natural Science and the ICB (Institute of Biological Sciences) PUC Minas.

The project "Implementation of the Forest Interpretive Trails PUC Minas, Campus Eucharistic Heart" was proposed and performed by students of Biological Sciences at PUC Betim, Minas Gerais, Jesica Alves Leite Dutra and Lidia Poliana da Rocha Afonso, in the 1st half of 2009 by Discipline Bachelor Stage I, under the guidance of Professor Miguel Ângelo Andrade (Professor at PUC Betim and Coordinator of the Biological Sciences at PUC Minas), and Co-supervision of Ana Cristina Diniz Sanches (Division of Education - Museum).

The second phase of the project, underway since August 2009 is the construction of parts and development of interpretive script from a universal design, aimed at the accessibility of various groups, including the blind, wheelchair users and the elderly, promoting and encouraging interest in conservation.

The trails are excellent tools for environmental education, stimulating the capacity for observation and reflection.

The environmental interpretation is a way to bring men to rethink the way they see and feel the planet as a whole, from direct contact with the natural surroundings, revealing the everyday reality and rethinking their attitude.

#### 4. References

- [1] BOFF, L. Ecologia e espiritualidade. In: TRIGUEIRO, A. (org.). Meio Ambiente no século 21. Rio de Janeiro: Sextante, 2003.
- [2] CAPRA, F. Alfabetização Ecológica: desafio para a educação do século 21. In: TRIGUEIRO, A. (org.). Meio Ambiente no século 21. Rio de Janeiro: Sextante, 2003.
- [3] \_\_\_\_\_. 50 Coisas Simples que as Crianças podem fazer para Salvar a Terra. The Earth Works Groups. Tradução: Reynaldo Guarany. Ed. José Olympio
- [4] DIAS, G. F. Educação Ambiental: princípios e práticas. São Paulo: Gaia, 1992.
- [5] DIEGUES, Antonio Carlos. O mito moderno da natureza intocada. 4. ed. São Paulo: 2002.
- [6] FERRARI, Aída Lúcia; CAMPOS, Elisa. De que cor é o vento? Subsídios para ações educativo-culturais com deficientes visuais em museus. Prefeitura de Belo Horizonte, 2001.

- [7] FREIRE, P. *Pedagogia da Autonomia. Saberes Necessários à Prática Educativa*. 38<sup>a</sup> Edição, 1996.
- [8] \_\_\_\_\_. *Manual de Introdução à Interpretação Ambiental elaborado pelo Projeto Doces Matas – Minas Gerais (IEF/IBAMA/Fund Biodiversitas/GTZ. Outubro de 2002)*
- [9] MARANDINO, M. *A Pesquisa Educacional e a Produção de Saberes nos Museus de Ciências. História, Ciências, Saúde-Manguinhos, Rio de Janeiro;*
- [10] \_\_\_\_\_. *O Pequeno Cientista Amador. Organizadora: Luisa Massarani. Série: Terra Incógnita. Casa da Ciência, 2005;*
- [11] \_\_\_\_\_. *Unidade de Políticas Públicas – UPP. Município Acessível ao Cidadão. Coordenado por: Adriana Romeiro de Almeida Prado. São Paulo, 2001.*
- [12] VASCONCELLOS, Jane N. de O. *Educação e Interpretação Ambiental em Unidades de Conservação. Paraná: Fundação O Boticário. Caderno de conservação. 2006. ISSN 1807 5088*
- 
- 

## Support Material for In-school Hands-on Experiments

B. Rangachar  
Founder Executive Director, Clt India,  
Jakkur Post & Village,  
Bangalore -560 064, INDIA  
bhagya@cltindia.org

**Abstract.** Expanding learning opportunities and giving access to quality education for children in under-served communities has been the focal point of CLT's developmental work since 1997. Technology has been an enabler in this key process. To counter and respond to shortage of elementary school teachers and resource-starved government schools, CLT has engaged in sourcing teachers with subject-expertise and digitally capturing their pedagogical practices. Multi-media and video-recorded content as ICT Tools is integrated with classroom teaching to make it more effective. For experiential learning, as support material for popularizing Hands-On-Science, demonstration experiments as DVDs, hand-written-notes and a Touch & Tell lab is given.

**Keywords:** hands-on science, ict tools, support materials, television, videos.

### 1. An NGO perspective

This Paper is written with an NGO perspective at the grassroots level. Our scale of operation is small with 40 plus schools, but our involvement in the last ten years working with Government schools in and around Bangalore and in the interiors has been at a very deep level. At CLT, our work has involved working with one government school with 1,000 children in semi-rural area for 5 years where we provide e-support. An After-school Centre – Intel Computer Clubhouse at CLT- consists of kids from 5-6 villages where technology is central, and approach to learning is exploratory, peer-peer, self-directed, constructivist and mentor-driven. Currently, CLT is engaged in building e-content repository in English and Kannada for State Board syllabus and is being used in 40 government schools, 3 English medium private schools with State Board syllabus, and one non-formal school for construction workers' children.

## 2. Scope for alternative education

In this article, the author explores the missed opportunities for learning in the resource-starved rural Elementary Schools in India and the challenges teachers face in a given day.



Figure 1. Resource-starved classroom

It also puts forth arguments that support the need for Alternative Education- as early as Elementary Education- and how Education through Technology can play a role in tackling some looming issues in rural schools in India.



Figure 2. Teacher absenteeism

As it is generally understood, Alternative education has a role to play wherever and whenever schools and communities can not fulfil their commitment to give a conducive learning environment for their kids.

That could be for various reasons- schools not nearby or just a shell for a school; teachers with

multiple classes, teachers not qualified or no teachers for many periods, as commonly seen. As a matter of fact, teachers are not appointed for each grade; it is by number of students.<sup>1</sup>

Percentage of Single-Classroom Schools by Category: 2005-06

School Category	Number of Classrooms				
	All Schools/ All Areas	Rural Areas	Urban Areas	All Government Schools	All Private Schools
Primary Only	13.52	14.13	7.29	14.56	4.25
Primary with Upper Primary	1.78	1.95	1.05	2.02	1.09
Primary with Upper Primary & Secondary/ Hr. Secondary	1.09	1.25	0.82	1.65	0.72
Upper Primary Only	3.31	3.44	2.10	3.35	3.15
Upper Primary & Secondary/ Hr. Secondary	0.91	1.07	0.44	1.21	0.53
<b>All Schools (All Areas)</b>	<b>9.54</b>	<b>10.37</b>	<b>3.99</b>	<b>11.04</b>	<b>2.43</b>
All Schools (2004-05)	10.39	11.33	4.45	11.78	2.62
All Schools (2003-04)	10.94	11.86	4.96	12.24	2.62
All Schools (2002-03)	12.08	13.05	5.82	13.35	2.51

Figure 3. Single classroom statistics

The smaller the village the more chances are there that an entire school of 6 grades has less than 40 kids and the school is not eligible for more than one teacher. Even schools having extra classrooms, combine all grades in one room, with the teacher juggling between assignments on different Black Boards.



Figure 4. Combined classrooms

The strategies for achieving Universal Primary Education with the expansion of enrolment and gender parity have been successful. However, with regard to the retention and survival rate to the last grade to complete elementary education is around 60% and the quality of education is till an issue.<sup>2</sup>

The World Education Forum in 2000 emphasized and set goals for Education for All and The Right to Learn with a commitment to expanding learning opportunities for everyone.

In the context of India, where two thirds of the population lives in villages, it is seemingly more challenging to attain the Millennium Development Goals without giving access to the opportunities. While schools need to be upgraded without a doubt, they can not be the only platform for the diverse educational needs of the rural population. The time is ripe, as other researches recommend, for several strategies to come together for a flexible amalgam of formal, informal and non-formal approaches to provide e-strategies to support rural education in India.<sup>3</sup>

### 3. Education technology



Figure 5. Teacher-mediation

We have learnt from our own experience of working with rural government schools, and other supporting research, that the remoteness of schools greatly affects quality of education and that the relative change Educational Technology would make is far greater at the bottom of the pyramid, thus supporting the argument that “ET should reach the under-privileged first and not the other way around”<sup>4</sup>

Remoteness generally implies that the schools are in the interiors and are insulated in many ways without the access to opportunities. On the other hand, it could also include communities that may not be in the interiors, but are excluded from the opportunities that ‘good schools’ offer.

This Paper is based on our work at CLT Resource Centre, a hub that draws teachers from all disciplines to share their best practices. The multi-media content with video-based recordings make its way to spoke schools as DVDs under the banner CLT e-Patashale.

Here, e-support content is intended to be absorbed in 3-4 ways as the situation demands;

as a support tool for teacher-mediation; as filler where the teacher might not have in-depth subject-expertise or for a substitute teacher; kids facilitating a e-lesson during teachers’ absence.

The point in case is about inculcating scientific and technological temper for the mainstream schools with the limitations the system has at present. What does the current environment offer? Kids are the passive recipients of information in a directed or controlled space where the communication is dictated by outdated practices of exchange of information from the textbook to the blackboard to the kids’ note books. If time permits, repeat everything in a chorus.

### 4. Capturing the teaching moment



Figure 6. Video capture of teaching

A good teacher doing a Science lesson relating to familiar things and situations, with hands-on experiments with locally available materials, virtual though it might be, seems to be the next best thing to a good teacher in a good school with appropriate resources. As the situation warrants, support materials in the form of customized lessons with value additions, teacher-aids, experiments, live-recorded lessons by good teachers could fill the lacunae and bridge the divide that the remote schools face. I would like to add that a special emphasis is placed for CLT e-Patashale Science content to ‘capture the teaching moment’.

The process is about exposing best practices of inquiry-based, activity-based, applied learning through live video-captures as opposed to only graphics-design templates driving a Science lesson.

Out of the 40 schools that have the CLT e-Patashale content for more than a year, five

schools were observed for a period of 16 weeks, specifically for the Science content.

All teachers had 10 years of formal education with an additional 2 years of teachers training, except for one teacher with a college degree who hoped to get transferred to a High School. Four of the five schools were rural, while one was in semi-rural area. None of the teachers lived close to the villages and some had to travel 2 hours by bus to reach the school. Hence there were some culturally accepted delays.



Figure 7. Transfer of heat

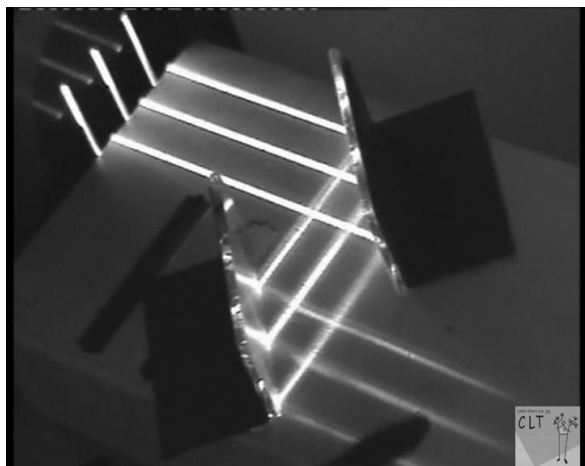


Figure 8. Reflection of light

## 5. Our learning

Initially, when we first introduced ET, we were met with the same dialogue as most would with technology – an external foreign element that needed to be dealt with special training and time-slots etc. Almost none of the teachers did any mediation between technology and black-board due to the discomfort in switching gears from technology-aided teaching to delivery.

They would use it as one special class during the week. Later, when the format of our content changed to suit their needs better with easy navigation and localization -it was also broken down to many small components giving flexibility for mediation - they gained more confidence to integrate with their teaching. It was generally used as supplementary material after the initial black-board writing in 2 schools. They also liked the images and voice-overs and said that it made it easy to understand the concepts. 2 other schools used it as filler as they found Science too challenging to teach. However, one teacher that had a Science degree was ambitious enough to try a few experiments himself. Although he didn't want to be teaching in Elementary Schools forever, being more qualified than the rest of the teachers with a Science degree, he made many trips to CLT Resource Centre asking for more experiments.

Yet, it is not to say that these Science experiments are being experienced by all the children in hands-on fashion,. However, it changed the classroom dynamics with teachers exhibiting more confidence to engage children with queries; they were facing the children more and the blackboard less, thus making themselves little more accessible to children. Kids were more animated as they were engaged. Teachers would Pause and add their comments to the video experiments. Kids would watch the experiments that were very doable, in some cases, with a lot of interest.

Few months back, we converted all the DVDs to be played on TV/DVD, as well.

Other unrelated observations - Couple of teachers that had kids in elementary schools in small private schools wanted an extra set of copy to take home. During our observation, we saw a teacher writing something on the Black Board and realized that she had an error with the facts after watching the e-lesson. She then went back to the Board and corrected herself.

Some risk factors were stolen PCs – 3 out of 30 schools had PCs missing and teachers' reasons were less than convincing.

## 6. Conclusion

In our observations at the After-School Computer Clubhouse, we find that children are naturally drawn to Science and Technology without knowing what it is called! They find it

fun when they are engaged - hands-on. They tune out the monotone voice of a teacher coming at them at some point. It is about applied-learning, constructivist, peer-to-peer, collaborative, on their own, doing mistakes, correcting themselves etc. Teacher's role should be only to get their curiosity going to find out more about it by themselves and gradually, 'teachers' evolving to becoming 'Mentors'!

We have a while to go before breaking away from set patterns, especially in rural schools. In the interim, can we create other layers of support for the main stream schools? Although our content is more of an anchor, guide, resources and a teacher's support tool for many, few motivated teachers can emulate certain practices or do good mediation between technology and blackboard to make their teaching more effective.

A few days back, a friend who is educated and has his children in high-end private schools mused, "I wonder though what children gravitate towards if left on their own -on the web - it seems to be music, games..., art? My kids are influenced by peers and play Disney website games, I guess some may even read up on Science, maybe very few. My only question is that kids may not go towards learning, what is required to pass the exams or specific disciplines like math and science-which are required whether we like it or not for passing exams."

Could it be that that we don't apply our knowledge about how children learn naturally and build it into their everyday teaching/learning-hours? Left to themselves with things to explore, kids are continuously learning. Sugata Mitra has left us with a fascinating observation in one of his recent talks that learning is a Self-organizing system and parts of elementary education can happen on its' own!

Hopefully, this argument could lead us all to explore to come up with alternatives for newer vista in education with a special focus to foster Scientific and Technological temper!

## 7. Acknowledgement

We are very grateful to Prof D.R.Baluragi for his outstanding commitment and contribution towards development of activity-based science content with hands-on approach.

## 8. References

- [1] Pratham Foundation
  - [2] Future policy choices for education sector in Asia by Shailaja Fennell
  - [3] E-strategies to support rural education in India, by Kumar Misra, Pradeep
  - [4] Sugata Mitra - Lift Conference
  - [5] DISE - District Information System for Education  
<http://www.schoolreportcards.in>  
<http://www.azimpremjifoundation.org/html/statistics.htm>
- 
-

## The Creation and the Creator: A Rewarding Experience in a Functional Neuroanatomy Teaching Course

M.I. Nogueira<sup>1,2,3</sup>, W. Allemandi<sup>3</sup>, C.A. Chiroso-Horie<sup>4</sup>, C. Sitamoto<sup>5</sup> and S. Sitamoto<sup>5</sup>

<sup>1</sup>Biomedical Sciences Institute, Laboratory of Neurosciences, Universidade de São Paulo (USP), BRAZIL

<sup>2</sup>Institute of Psychology of University of São Paulo, BRAZIL

<sup>3</sup>Anatomy Department of Biomedical Sciences Institute, BRAZIL

<sup>4</sup>USP- Pro-Reitoria of Culture and Extension, BRAZIL

<sup>5</sup>USP- Pro-Reitoria of Culture and Extension, BRAZIL  
minog@usp.br

**Abstract** The adoption of alternative methods of teaching is essential in any educative approach, but they are precious tools when the purpose is to stimulate and awake creativity in students. The innovation we introduced consisted of requesting those groups, formed by three or four students, elaborate two three-dimensional anatomic models; one a general model of the central nervous system and the other specifically related to their area of interest. They should use the knowledge of the theoretical classes and respect anatomical proportions and relationships. Their creativity was encouraged through their choice of the anatomic region or structure of the nervous systems to model. It was required in their selection of the materials to be used too. The materials used were the most diverse; wool, electric strings, wires, wood, nails, hangers, fabric, paper, cardboard, plastic, hand moulded material, gelatine, and glue along with others. The beauty, diversity of form and richness of details enchanted both the experts and laity involved with the subject. The exposition by the students of the models at the end of the course, the exhibitions we performed at different places of the University and at the Science Museum during a special event of VI Exhibition of Material for Science Teaching and Social Inclusion, made us sure of how much the students got in return of their efforts at both:

knowledge and self confidence, working as volunteers in extra periods to show their **creation** to undergraduate and high school students, teachers and general visitors in a clear exercise of “hands-hearts and minds-on” as **creators**.

**Keywords:** science teaching, hands on science, creativity in teaching, 3D models, arts & science neuroanatomy.

### 1.Introduction

Teaching in anatomy as well as in related disciplines has been improved with more detailed knowledge of the body, of its macro- and microstructures, and the availability of such new resources as multimedia, computational equipment and programs. The increasing number of publications and events dedicated to the subject confirms this dynamic [1,2]. These efforts reflect the dedication and enthusiasm of committed professionals convinced of their ideals, and has thus influenced the conclusion that basic education is as fundamental as is research for the sense of nationhood of a people and country.

Individual efforts have been made to minimize the lack of necessary investment in education, and in both human and material resources [3]. The emphasis has been to strengthen pure research and the educational policies of many institutions have served to amplify the imbalance between research and education, especially where the professional has to shine in both activities, and besides administrative tasks as well. Some subjects, like Anatomy, face even additional difficulties [4].

Not only the educators but also the institutions recognize that even though many students have a natural motivation and even excitement at the possibility of handling and exploring anatomic material, still others are apprehensive and concerned about fixatives' smell, appearance of the corpses and presumed health risks. Actually, without proper warn and adherence to necessary security precautions, those risks might indeed become real. On the other hand, the specificity of some school program also promote disappointment to some students not complete aware of their choice. Another source of concern might be the presence of this discipline in the first semesters of college, when students are beginning their lives at the

university. This period represents for many of them the revealing of challenging possibilities and a traditional independence. These changes taken together with the absence of a direct or indirect tutor might promote concern and distraction. In addition, the students' erroneous impression that learning anatomy is limited to memorizing endless lists of names must be challenged.

In this scenario, goodwill and the right attitude might be decisively significant in overcoming or minimizing difficulties, attracting and getting the students engaged. Willing to try new approaches, we adopted many interactive procedures illustrating the vital compromise between form and function in the body's structures. In tandem with this, we decided to explore the creativity of the students asking them to plan and construct 3D models of the nervous system.



**Figure 1:** Collection of the different 3D models of the Central Nervous System produced. The mostly used materials was porcelain Doug (biscuit), strings, plastic tubes, glass bowl filled with gelatine (eye with nerves and muscles).

## 2. Material and Methods

Students registered in the courses of Speech, Audiology, Physiotherapy and Occupational Therapy, enrolled in our discipline of Neuroanatomy (one semester long) were challenged to be creators.

The innovation we introduced consisted of requesting those groups, formed by three or four students, elaborate two three-dimensional anatomic models; one a general model of the central nervous system and the other specifically related to their area of interest. Their creativity was encouraged through their choice of the anatomic region or structure of the nervous

systems to model. It was also required in their selection of the materials to be used. The construction of the model would have to reflect the anatomical and topographical relations and proportions of the human bodies, according to a selected biotype. This proposal aimed to offer an opportunity to the students to apply the knowledge obtained in theoretical lectures and practices, to the task of configuring and constructing the 3D models. This activity, besides demanding attention to the spatial organization of the body, emphasized anatomic and functional differences, intra-specific and gender variability, and also pathologic alterations.

The proposal was received with the usual enthusiasm and receptivity displayed by students. The appraisal of the completed models was scheduled for the end-of-term, through a presentation in front of the whole class, when not only the presentation but also the fulfilment of the required topics and the quality of the model would be considered.

## 3. Results

We were positively impressed at the creativity and dedication reflected in the models. The beauty, diversity of form and richness of details enchanted both the experts and laity involved with the subject. The materials used were the most diverse; wool, electric strings, wires, wood, nails, hangers, fabric, paper, cardboard, plastic, hand moulded material, gelatine, glue along with others. For example, among the produced models there were an anatomic brain atlas made with superposition of transparencies, and an animation program of neuroanatomy for PC computer (figures 1-6).

The enthusiasm these models aroused among colleagues from others disciplines encouraged us to prepare the first exposition. In this particular instance we felt attracted by the opportunity to recall and reinforce the following aspects: the history of the anatomy, its social, artistic and scientific importance, but also, specifically to illustrate to the students that: the manifestation of creativity in its various forms is essential to the accomplishment of the continuous exercise of living at the professional and personal activities.

This first exhibition was mounted at the library of the Institute of Ciências Biomédicas of the Universidade de Sao Paulo (Brazil), as part

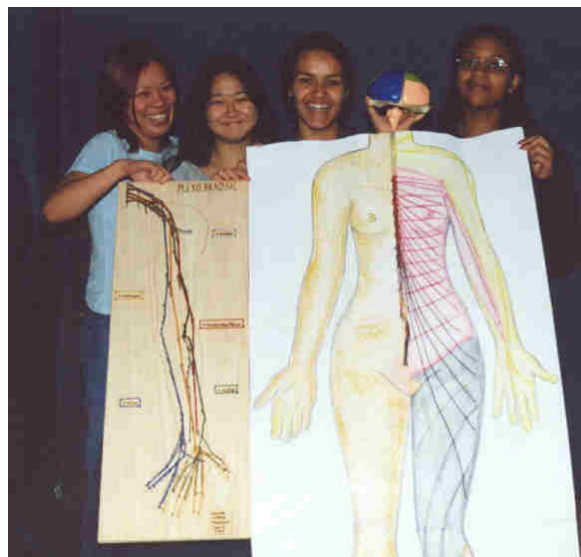


of the library's annual commemorations week. An explanatory card with a clarifying text was developed to accompany each model displayed. The written information consisted of the title, the objectives and significance of each model, a list of the materials used as well as the name of the students and their basic specialization. An oversized poster explaining the origins and development of this experience was added to the exhibition as a whole. This poster summarized the history and scientific importance of the anatomy and neurosciences.

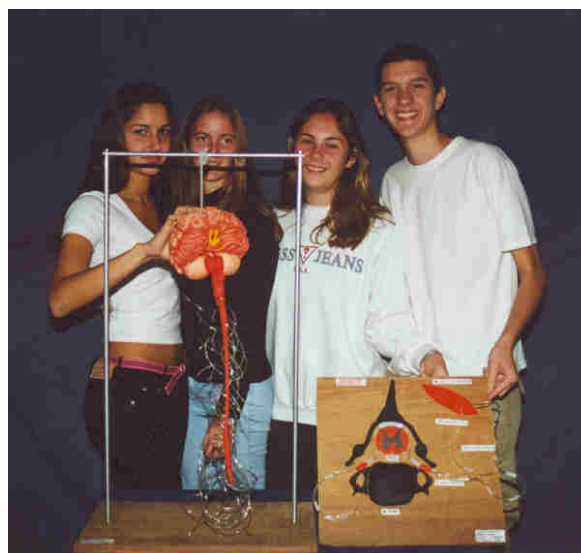
Among the many positive comments related to the exhibition, we point out the observation of one professor on the model of the upper member. This model was built up over a wood plate, in which wool strings of different colours and nails were used to represent the contours of the arm, forearm and the hand, depicting their respective innervations in different levels of depth (figure 2A) according to the height of the string as attached to the nail. The professor found very interesting and didactic the resource promoted by this model, because it made so easy to visualize the effects of an anesthetic on a certain area in relation to the point of its injection.



**Figure 2:** 3D models of the Nervous system. **A.** Spinal nerves of the arm represented by strings of wool attached to nails in a wood plate. **B.** Woman body depicting the central nervous system and at the left side different spinal nerves and respective dermatomes, produced with biscuit and cardboard.



**Figure 3:** Afferent nerve fibers passing through the various levels of the Central nervous system. Strings and cardboard drawings were used.



**Figure 4:** 3D models of the Nervous system. **A.** Central nervous system produced with biscuit and plastic tubes hanging in a metallic support. **B.** Model of a spinal cord inside a vertebra, illustrating a muscle reflex, the same material as model A was used.

The repercussion of the exhibition performed at the library and the enthusiasm of the participants and visitors, encouraged us to register it in the VI Exhibition of Material for Science Teaching and Social Inclusion, a symposium of the Estação Ciência of the Universidade de Sao Paulo, The Science Museum. Once accepted for registration, the models and their explanatory texts and poster were exhibited for five days (figures 7 and 8). Undergraduate students and some of the post-

graduate students of the Anatomy's program took alternating turns as volunteer monitors to explain the objectives and details of the models.

The low cost, beauty, functionality of the models along their didactic possibilities made a very good impression on teachers and students of the primary and high school levels. A similar exhibition was requested by the Institute of Psychology, Program of Neuroscience, at the beginning of the classes of that year. This last one deserved a special report at the newspaper of the university "Jornal da USP" nominated "Nerves of string". Later, this same exhibition was installed at the Institute Biomedical Sciences to the arriving students in general. Part of it, was also at the internet in the site of the Section Culture and Extension Program, for some time, it was relatively well consulted, and was also reached by the Google site. Most students report at the end of the semester they never had so much fun and leaned so enthusiastically, what was confirmed by their grades which median was 40% higher when compared to the students of the previous course.



**Figure 5:** 3D model of the Nervous system inside a plastic doll. **A.** Dermatomes drawings at the anterior surface and **B.** inside representation with electric strings of the spinal nerves at the right side of the body attached to the central nervous system made of biscuit.



**Figure 6:** 3D model of the muscle spindle reflex, representation with the central nervous system. Strings and biscuit were used and a raincoat hanger.



**Figure 7:** Stand with the models at the VI Exhibition of Material for Science Teaching and Social Inclusion "ICB / USP" – Estação Ciência.

#### 4. Discussion

The knowledge of human anatomy is indispensable to the exercise of professionals in the area of health and physical activities. It requires a basic code, as the alphabet, say, of some basic structures from which others are derived, obeying topographic and functional relationships. This understanding is accomplished with the comprehension of the specific relations pertaining to the different components of the human body [5]. Aristoteles (384-322 AD), considered the first comparative

anatomist, identified the human being as the most complex animal, recognizing that the diversity of forms results from the variable potential of each organism to explore the environment. Approximately 500 years later the Greek physician, Galeno of Pergamon (living in Rom, second century AD), in recognizing the preponderance of the function over the shape, achieved contributions that lasted for more than 11 centuries, period of the decline of the roman kingdom [6]. Thus, these contributions established the influence of the environment and its function on the shape and architecture of the body [6,7]. Aspects we planned the students to understand through the constructions of 3D models observing the structural relationships and proportions in the human body.

However, art and science exert a crucial role in awaked creativity that should not be ignored. Which would be the relations among: Anatomy, Art and Science?



**Figure 8:** Part of the student team working as volunteer to present the models at the VI Exhibition of Material for Science Teaching and Social Inclusion. At the right we see Prof. E.Hamburger, Director of the Estação Ciência, using glasses, and at the center C.Mattos, Director of events of the same Science Museum.

Let's rescue some history; in the Renaissance, the artists habitually studied the human body in detail, to better reproduce it. According to that movement, art is a creation of the intelligent linkage of conception and observation. Thus art is under the rule of perfection that might be conquered even formulated to be taught with precision [6]. A splendid result of genius and rigor of representation of human body is the artistic work of Michelangelo Buonarroti "The Creation of Adam" (part of the ceiling of the Sistine Chapel, at the Saint Peter's Basilica, Rome). A contemporaneous important

renovation at the academic-scientific environment was promoted by Andreas Vesalius, physician considered the founder of the modern anatomy. Vesalius, against the principles of the Catholic Church, studied and taught through dissecting corpses. One of his important contributions is the awesome book "De Humani Corporis Fabrica" (1543), illustrating in different planes and positions, the various parts of the human body, which until that time was bare and many times erroneously represented. The title of the exhibitions we performed was a reference to the splendid Michelangelo's work referred to, and the creative process experienced by the students, reaffirming and illustrating the audacious contribution of Vesalius.

At this point, one might be curious about neuronatomy, its origins, the evolution of the nervous system and its role as science. The phylogenetic aspects of the nervous system were considered by Charles Darwin (1809-1882), with his contemporary Thomaz Laycock (1812-1876) referring to the phylogenetic scale emphasized in the encefalization process the organic basis for the gradual substitution of simple vital process, by the instinct and from this by the mental faculty. The higher complexity of the encephalization is observed in the human being, and it is evident in arts and science as an expression of mental power. The integrated and plastic ability of the nervous system deriving from its hierarchical functioning was identified by Herbert Spencer, 1855, when he established that in the CNS, new structures or layers were superimposed to attend the demand of exploration of diverse environments [6, 7, 8].

Among other considerable landmarks, the origin of the neurosciences is attributed, at the beginning of the XIX century, to the German Ludwig Edinger and to the American brothers Clarence and Charles Herrick, whose works acknowledge that the complexity of the CNS was achieved by the addition of new elements (forebrain) over one basic structure, phylogenetically ancient, related to the vital functions (the brainstem) [6]. The end of the century XX presented a considerable evolution in the amount of information related to the nervous system concerning its organization, connections, and mechanisms of action, cognitive and behavioural process, among many other aspects. The years 1990-2000 were nominated "The Brain Decade" due to the amount and the quality

of research accomplished [9]. Nevertheless, challenges still remain; provoking our minds, depicting that there is much more to be explored.

Working with the students on their feelings and the impression left with “lay people” it became easy to them realize how frequently the acquired knowledge might be classified as banal or trivial. That is, in the workday environment where it was generated; but when considered alongside diverse cultural backgrounds its importance stands out [10, 11].

The student’s oral presentations of the results conformed to the usual pattern to their age, with some allowance for inhibitions and undervaluation of their own efforts. However, when reporting to the class the impression made and on their family, friends and whoever had followed the evolution of the work their admiration and interest on the task in progress became evident along with its scientific and clinical implications.

This additional exercise of reflection confirmed the value of the study in light of the different ways of reporting it, in both personal and professional life. An additional interesting gain of this task — again of students producing models based on outside information they had to acquire — was the achieved integration among the disciplines they were taking at that time, whose dynamics involved other teachers, and their disciplines, in questions about the body and the specific subject they choose to represent. For instance, in the building up of a model on the monosynaptic spinal arc reflex, comprising the muscle, its muscular spindles and its different afferent and efferent fibers, the spinal cord level at the origin of that specific nerve, as well as its dorsal, ventral, ipso- and homolaterals horns, the physiology teachings were linked to the anatomy ones. Impressions registered by other teachers, lecturing those students, confirmed how important was the adoption of the philosophy of hands- hearts- and minds-on [12,13] since it promotes activation of multiple brain areas therefore making learning, memory consolidation more effective [9,11].

## 5. Conclusion

Teaching and learning might represent a simultaneous enjoyable and effective activity. Science and art might coexist, awaking interest and spreading knowledge. Joining different

generations; as was the case in this experience seniors and young adults promoted enriched contributions and proved the multidisciplinary nature of the construction of knowledge. Teaching and learning are activities that require dedication, but that also bring rewards, which deserve personal and institutional investments.

The generation of this manuscript was stimulated by the belief that a positive experience should be shared, but even more important, it aimed to encourage procedures that grow out of the emphasized aspects of this work — cooperation, creativity and search.

“A teacher affects eternity; he can never tell  
where hers/his influence stops”

A. Henry Adams.

## 6. Acknowledgements

The authors acknowledge the stimulus and support of Dr. Margarida de Mello Ayres from the Committee of Cultura e Extensão of the Institute of Biomedical Science, Dr. Ii-sei Watanabe Chairman of the Anatomy Department, the NAP-NeC (IP-USP) and EC Azmitia by the stimulus, as well as the priceless help of Dennis M. Mardon and Charles Jules “friends forever”.

## 7. References

- [1] Chopin, SF. Undergraduate Research experiences: The translation of science education from reading to doing. *The Anatomical Record*. 269:3-10. 2002
- [2] Haines, DE., Hutchins, JB. and Lynch, JC. Medical Neurobiology: Do we teach Neurobiology in a format that is relevant to the clinical setting? *The Anatomical Record (New Anat.)* 269:99-106. 2002
- [3] Duschl, RA, Schweingruber, HA. And Shouse, AW. Taking Science to School: Learning and Teaching Science in Grades K-8 Committee on Science Learning, Kindergarten through Eighth Grade. 2007
- [4] Philips-Conroy, J. The uncertain future of Gross Anatomy. *Science*, V.300. p. 2031.2003.
- [5] Blits, KC. Aristotle: from, function, and comparative anatomy. *Anat REc (New Anat.)* 257:58-63. 1999.

- [6] Finger, S. *Origins of neuroscience: A history of explorations into brain function*. Oxford University Press, 2001.
- [7] Hein, GE. *Constructivist Learning Theory: The Museum and the Needs of People*. CECA (International Committee of Museum Educators). Lesly College. Massachusetts USA, 1991.
- [8] Tattersall, I. *Becoming Human. Evolution and Man Uniqueness*. Harcourt Brace & Company, New York, 1998.
- [9] Novack, CR; Strominger, NL; Demarest, RJ. and Rugiero, DA. *The Human Nervous System Structure and Function*. Sexta edição. New Jersey, EUA: Humana Press Inc, 2005.
- [10] Bear, MF. and Connors, BW; Paradiso, MA. *Neuroscience: Exploring the Brain*. Third Edition, Lippincott Williams & Wilkins, 2006.
- [11] Hein, GE. *Constructivist Learning Theory: The Museum and the Needs of People*. CECA. (International Committee of Museum Educators). Lesley College. Massachusetts, USA. 1991.
- [12] Bransford, JD; Brown, AL. and Cocking, RR. *How people learn: brain, mind, experience and school*. Expanded Edition. 2000. National Academic Press at: <http://www.nap.edu/catalog>.
- [13] Pavão, AC. and Leitão, A. *Hands-on? Minds-on? Hearts-on? Social-on? Explainers-on? 45 Dialogos & Ciência: Mediação em museus e centros de Ciência*. Ed. Luisa Massarani, Rio de Janeiro: Museu da Vida/Casa de Oswaldo Cruz/Fiocruz, 2007.
- [14] Wagensberg, J. *Debates on Education: Educating on the border between intuition and comprehension*. Initiative of the Jaume Bofill Foundation and the Universitat Oberta de Catalunya, 2004.  
<http://www.debats.cat/eng/2004/wagensberg/index.html>
- 
- 

## Hands-On Optics: Training Courses For School Teachers

M.F.M. Costa<sup>1</sup> and B.V.Dorrió<sup>2</sup>

<sup>1</sup>Universidade do Minho, Dept. de Física  
Campus de Gualtar, 4710-057 Braga  
PORTUGAL

<sup>2</sup>Universidad de Vigo,  
Esc. de Ingenieros de Minas, Dept. de Física  
Lagoas, Campus de Marcosende, Vigo,  
GALICIA-SPAIN

[mfcosta@fisica.uminho.pt](mailto:mfcosta@fisica.uminho.pt); [bvazquez@uvigo.es](mailto:bvazquez@uvigo.es)

**Abstract.** For long time optics' scientists all around the world realised the importance to the development of optics of providing our school students a good effective education in optics. A large range of quality educational support materials was developed and is readily available. Fortunately this is also true in what concerns materials to be used in hands-on experiments based learning covering virtually all fields of optics and also intended or adapted for use at all school levels. Recent trends in educational policies are given science education an increasing importance within school' curricula. Further efforts must be developed in order to increase the importance of optics in school syllabus and generalize it throughout all school levels, while guaranteeing a quality effective education. This demands a strong focus on an active investigative hands-on experiments based study of the different subjects of light and optics by the students at the classroom in formal context but also in different informal activities. In this process the role of the teacher is of crucial importance. Quite often, however, teachers are not adequately trained in this type of pedagogic approach and frequently feel the need of further training in these issues but also on the recent advances of optics and photonics. In order to tackle this need a number of different training courses for school teachers, from pre-school to high school and vocational training schools, were designed and will be presented and discussed in this communication.

### 1. Introduction

Science teaching at all school levels should be generalised and rendered more effective in order to guarantee a strong and sustainable

improvement of Science and its technological applications while improving and extending scientific literacy in our societies [1]. All over the world this is being, fortunately, accepted by governments and civil society institutions. Europe calls for more Science and Technology graduates trying to achieve the targets set in Lisbon Strategy to make the European Union "the most dynamic and competitive knowledge-based economy in the world capable of sustainable economic growth with more and better jobs and greater social cohesion, and respect for the environment by 2010" [2-5].

These demands add increasing pressure to the school and to school' teachers. Science teachers in particular face higher demands. In these troubled times students and teachers themselves (all of you in fact...), can hardly foresee a future coherent career, teachers must find ways of attract [6] and engage the students into the learning process. Informal and non-formal activities can have a very positive impact [7,8] but in-classroom activities are fundamental and here a hands-on investigative experiments based active learning is fundamental [9]. Unfortunately frequently our science teacher were trained in an essentially theoretical way and are not used to perform experiments and even less to induce or even allow the students to act hands-on, not being taught to understand the process or trained for it.

Light, Optics and Photonics have a crucial importance in our lives and to the prospects of development of our world with breathtaking developments in many different fields, including fibber optics sensor and communications, image acquisition and processing, lasers, photodynamic therapy, real time holography, optical computing, solar energy conversion and light sources... There is a lot of on-line information provided by universities, museums,... that can be directly employed by teachers [10-18].

On these lines we have developed and are running training courses [19] on hands experiments teaching approaches. The general objectives of these Hands-on Optics, supported by the European Commission (Life Long Learning/ Comenius action) are to provide schoolteachers from basic to secondary and vocational schools strong effective knowledge on the basics of optics, focusing on an intensive training in the execution of hands-on experimental activities on the major optics

subjects. Hands-on/minds-on skills will be developed allowing the teachers to organise experimental activities in their class in a confident and effective way (Figure 2). So protocols for searching proper information related with the main topics covered during the course are given in such a way that selected hands-on optical activities can be carried out in an independent way in the future [for example, 20-25].

## 2. Methodology

The early as possible in their education the students should introduced to and get acquainted with basic optics concepts as those related to the nature of light, the subjects of general optics, geometrical physical and quantum, but also with advanced subjects of utmost importance and actuality as wave guidance, fibre optics and telecommunications, image digitalization and processing, light production and energy conversion, optical processing and computing,... Not only specific knowledge must be acquired but also and specially the ability of exploring reasoning, acting interactively to be able to find, analyse and solve new interdisciplinary problems, should be explored and enhanced as extensively as possible.

The best way of achieving an effective sound education of the students on these optics issues is by inducing the students to an active committed participation in the teaching/learning process, through investigative practice and experimentation, making use of the new instruments and resources of the Information Society. Although a strong focus should be put into these hands-on approaches the theoretical perspective should not be forgotten and introspective abstract reasoning activities should be allowed, in particular if the characteristics of a student or group of students advise it. Constructivism [26] construcionism [27] and conceptual learning [28] among many other approaches should be explored.

## 3. The structure of Hands-on Optics training course

Although there will be a theoretical introduction to the theme, the course's methodology will essentially be based on practical experimental activities hands-on/minds-

on, followed by reflection and discussion. There will be a final assessment/evaluation session.

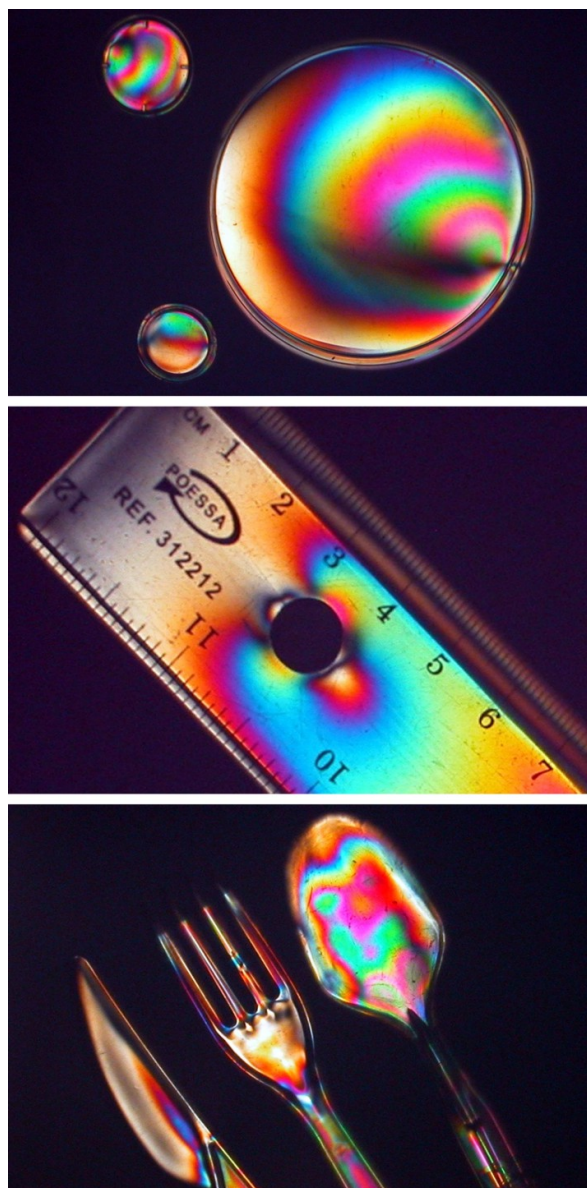


Figure 1. Hands-on Optical Activity: Light Polarization and Birefringence.

The pedagogic approach we suggest to be used relies on a functional integration of different pedagogical theories and practices namely the constructivism, conceptual learning and pro-active learning by hands on experimentation and research. Responsibility, critical reasoning and observation, method and flexibility, interdisciplinarity, volunteer self-rewarding commitment, joint efforts and teamwork, are the main keywords that should guide all pedagogical activities. Making use of

the new instruments and resources of the Information Society [10-18].

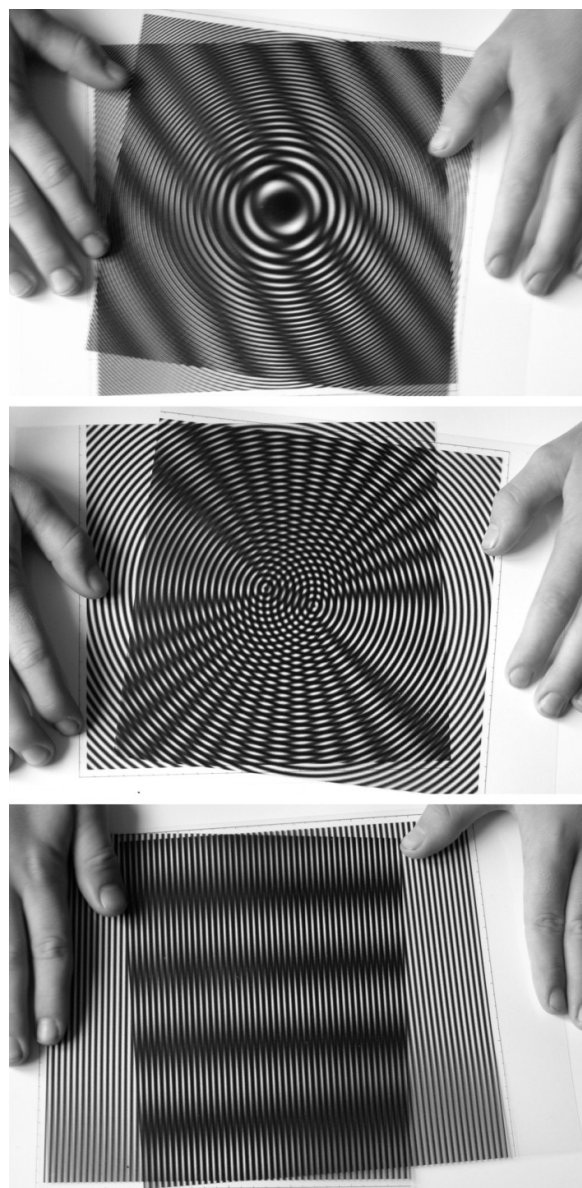


Figure 2. Hands-on Optical Activities: Moiré effect.

The week long training course is mostly practical and strong personal interaction among the students (the physics and science teachers) and with the trainers and tutors is expected and will be encouraged (enforced...).

We expect the teachers to act as students also in order for them to better understand the problems difficulties and behaviours of their own students.

Apart from the main curricular optics subjects we introduce lectures and workshop on transversal issues like motivational tools and activities including the resource to non-formal or

informal activities. Computer modelling and simulation tools can be very useful in helping complementing or even inducing hands-on experimental works. Often teachers work “alone” and feel that way.

call “Continuous” provides a series of observation based investigative activities covering basic light and optics concepts presented in an essentially non-guided way. The essential idea here is not to “show” or present an experiment but yes to induce the discovery process [35].

The follow-up of the course participants is considered of the highest importance. Enquiries and quizzes will be delivered to the teachers, together with support material to be filled by the teachers themselves and their students for a period no shorter than 3 years, to be returned to the course organiser for analysis and statistical treatment. Further training courses on more advanced topics will be made available in a near future [19]. On the other hand we expect the participants to enrol and be active members of the Hands-on Science Network were they will find a mutually supporting and nourishing ground [19].

In Figure 3 we show the schedule of the two Hands-on Optics training course run in 2009 in Spain and Portugal [35].

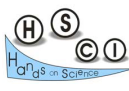
1 <sup>st</sup> Training Course on Hands-on Optics, April 3 to 11, 2009, Vigo, Pontevedra, Spain & 2 <sup>nd</sup> Training Course on Hands-on Optics, September 3 to 11, 2009, Braga, Portugal	
<b>Syllabus:</b>	
1st day 18:00 Registration	
2nd day 9:30 Opening and presentation, M. F. Costa 10:00 Optics: Past, present and future B. Dorrio, D. Sporea, M. F. Costa, 11:30 Hands-on science P. Michaelides 14:30 Introduction to optics. The basics I. M. F. Costa, B. Dorrio, P. Michaelides 17:00 Discussion	
3rd day 9:30 Constructivism. Theory and practice I. S. Gatt 11:30 Constructivism. Theory and practice II. S. Gatt 14:30 Introduction to optics. The basics II. M. F. Costa, B. Dorrio, P. Michaelides 18:00 Discussion	
4th day 9:30 Introduction to optics. The basics III. M. F. Costa, B. Dorrio, P. Michaelides 14:30 How to organise a hands-on experiments class. The scientific method P. Michaelides 16:30 Safety issues D. Sporea 18:00 Discussion	
5th day Free day. Visits to local schools and interaction with local teachers and students	
6th day 9:30 Hands-on activities I. The nature of light. B. Dorrio, C. Lima, M. F. Costa 14:30 Hands-on activities II. Color and vision. N. Tsaglotis, J. Fernandes, M. F. Costa 16:30 Hands-on activities III. Reflection and refraction. J. Fernandes, N. Tsaglotis, M. F. Costa 18:00 Discussion	
7th day 9:30 Hands-on activities IV. Ray tracing. M. F. Costa, R. Batista 11:30 Hands-on activities V. Prisms lenses and mirrors. J. Fernandes, C. Lima, M. F. Costa 14:30 Hands-on activities VI. Fiber optics, polarisation, diffraction, holography. M. F. Costa, N. Tsaglotis, C. Lima 18:00 Discussion	
8th day 9:30 “Funny” optics. Ideas for Science Fairs. M. F. Costa, P. Michaelides, B. Vasquez 11:00 Computer simulation on Microsoft Excel. V. Fonseca 14:30 Commence EU School’ cooperation projects. M. F. Costa, P. Michaelides 16:30 Course’ evaluation and conclusion 19:30 Farewell dinner	
9th day Departure	
<i>(Every day: Coffee break - 11:00 and 16:00; Lunch 12:30; 19:30 Dinner)</i>	
Trainers: Professor M. F. M. Costa (University of Minho), Professor B. Dorrio (University of Vigo), Professor F. G. Michaelides (University of Crete), Professor S. Gatt (University of Malta), Dr. D. Sporea (NIPNE), Prof. V. Fonseca (University of Minho). Tutors: Dr. N. Tsaglotis, Dr. R. Batista, Dr. C. Lima, Dr. J. Fernandes.	

Figure 3. Program of the “Hands-on Optics” training course

The establishment of cooperation mechanisms among schools and teachers from the same environment but especially when coming from different countries and cultures [29] may be very important for the teachers and individuals but also as educators. This issue will also be explored specially addressing the possibilities in the frames of the European Union foreseeing other opportunities (Erasmus Mundus like for instance).

The preparation for the course is considered important [30,31]. The participants receive in advance two Guides for Hands-on Experimental Activities and the Teacher’s Handbook, which contains a theoretical presentation on General Optics [32,33,34]. One of the guides includes 42 experiments, all to be explored during the course, divided into main topics and graded from elementary to secondary level. The other guide

#### 4. Conclusion

The development of optics and photonics requires a large number of well prepared highly motivated scientist and technicians that should be teach and trained as early and as efficiently as possible in a positive rewarding environment. The new stringent requirements of the modern society demand not only the gathering of specific knowledge but also and specially of the competencies the ability of acting interactively to be able to find, analyze and solve new interdisciplinary problems. The best way of achieving an adequate formation of our students on these issues is by inducing the students to an active committed participation in the teaching/learning process, through hands-on investigative practice and experimentation.

Teacher training activities on the hands-on investigative experiments based learning of optics in all school levels and in informal contexts should widely promoted and disseminated.

#### References

[1] Costa MFM; “Hands-on Science”; Selected Papers on Hands-on Science (ISBN 978-989-



- 95336-2-2); Costa MFM, Dorrió BV, Michaelides P and Divjak S (Eds.); Associação Hands-on Science Network, Portugal; pp. 1-13 (2008).
- [2] European Commission; White paper on education and training: Teaching and learning-Towards the learning society (White paper), Office for Official Publications in European Countries, Luxemburg (1999).
- [3] European Commission; Europe needs More Scientists: Report by the High Level Group on Increasing Human Resources for Science and Technology. Brussels: European Commission (2004).
- [5] European Commission; Science Education Now: A renewed pedagogy for the future of Europe, Brussels: European Commission Directorate-General for Research Information and Communication Unit (2007).
- [6] Lisbon European Council; 23 and 24 March 2000, Presidency Conclusions, ([http://www.europarl.eu.int/summits/lis1\\_en.htm](http://www.europarl.eu.int/summits/lis1_en.htm))
- [7] Lima CFS and Costa MFM; "Optics and Pool: Play the Game"; Selected Papers on Hands-on Science (ISBN 978-989-95336-2-2); Costa MFM, Dorrió BV, Michaelides P and Divjak S (Eds.); Associação Hands-on Science Network, Portugal; pp. 182-185 (2008).
- [8] Costa MFM, Dorrió BV, Muramatsu M and Pavão A; "Proceedings of the 5th International Conference on Hands-on Science. Formal and Informal Science Education" (ISBN 978-989-95095-3-5); Associação Hands-on Science Network, Portugal (2008).
- [9] Esteves Z, Cabral A and Costa MFM; "Informal Learning in Basic Schools. Science Fairs", Int. J. Hands-on Science; vol. 1, n.º. 2, pp. 23-27 (2008).
- [10] Costa MFM, Dorrió BV, Michaelides P and Divjak S (Eds.); "Selected Papers on Hands-on Science" (ISBN 978-989-95336-2-2); Associação Hands-on Science Network, Portugal (2008).
- [11] <http://demoroom.physics.ncsu.edu/>
- [12] <http://www.exploratorium.edu/snacks/>
- [13] <http://www.wfu.edu/Academic-departments/Physics/demolabs/demos/>
- [14] <http://physicsdemos.phys.cwru.edu/>
- [15] <http://www.fas.harvard.edu/~scidemos/demotoc.html>
- [16] <http://demolab.phys.virginia.edu/demos/demos.asp>
- [17] <http://demo.physics.uiuc.edu/LectDemo/>
- [18] <http://physicslearning.colorado.edu/PiraHome/>
- [19] <http://www.exploratorium.edu/snacks>
- [20] <https://webgate.ec.europa.eu/llp/istcoursedata/index.cfm?fuseaction=DisplayCourse&cid=7412>
- [21] Branca M and Soletta I; "Construction of Optical Elements with Gelatin"; Phys. Teach. 41 249 (2003).
- [22] Graham RM; "Real image produced by a concave mirror"; Phys. Teach. 44 186 (2006).
- [23] Gluck P; "Compact Disk Optics"; Phys. Teach. 40 468 (2002).
- [24] Gluck P; "Teaching Image Formation by a Lens"; Phys. Teach. 44 206 (2006).
- [25] Mak SY; "A simple method to determine the refractive index of glass"; Phys. Teach. 26 526 (1988).
- [26] Goodman DS; "Optics demonstration with the overhead projector" (ISBN: 1-55752-650-8); Washington:SPIE (2000).
- [27] Gatt S, "Constructivism—An effective Theory of Learning"; in Gatt S and Vella Y (Eds.), Constructivist teaching in Primary School Social Studies, Mathematics, Science, ICT, Design and Technology, Agenda Publishers, Malta, (2003).
- [28] Ribeiro C, Coutinho C, Costa MFM and Rocha M; "A Study of Educational Robotics in Elementary Schools"; Selected Papers on Hands-on Science (ISBN 978-989-95336-2-2); Costa MFM, Dorrió BV, Michaelides P and Divjak S (Eds.); Associação Hands-on Science Network, Portugal; pp. 580-595 (2008).
- [29] Zamarro JM, Molina GJ and Núñez MJ; "Teaching Physics Modelling with Graphic Simulations Tools"; Selected Papers on Hands-on Science (ISBN 978-989-95336-2-2); Costa MFM, Dorrió BV, Michaelides P and Divjak S (Eds.); Associação Hands-on Science Network, Portugal; pp. 69-73 (2008).
- [30] Sjoberg S.and Schreiner C; "How do learners of different cultures relate to Science and Technology? Results and Perspectives from the ROSE Project", Asian-Pacific

Forum on Science Learning and Teaching,  
Volume 2, Issue 6, Forward p.2 (2005).

- [31] Dorrió BV, Rúa A, Soto R and Arias J; “Hands-on Physics Bibliography”, Proceedings of the 1st International Conference on Hands-on Science, Teaching and Learning in the XXI Century, Divjak S (Ed.), 2004 July 5-9, Ljubljana, Slovenia, University of Ljubljana, pp.: 119-124, 2004, (2004).
- [32] UNESCO, 700 Science experiments for everyone, New York: Doubleday (1962).
- [33] Costa MFM, Hands-on Introduction to Optics / Introdução à Óptica (bilingual edition) (ISBN 989 95095 2 3), Hands-on Science Network, (2006).
- [34] Costa MFM; “Learning Optics at Basic Schools by Experimentation”; Selected Papers on Hands-on Science (ISBN 978-989-95336-2-2); Costa MFM, Dorrió BV, Michaelides P and Divjak S (Eds.); Associação Hands-on Science Network, Portugal; pp. 25-28 (2008).
- [35] Costa MFM; “Introduction to Fiber Optics and Telecommunications”; Selected Papers on Hands-on Science (ISBN 978-989-95336-2-2); Costa MFM, Dorrió BV, Michaelides P and Divjak S (Eds.); Associação Hands-on Science Network, Portugal; pp. 492-496 (2008).
- [36] <http://www.hsci.info/>
- 
- 

## Experimental Models of Urban Sustainability Based on Indicators

M. Sasek-Divjak

Urban Planning Institute, Trnovski Pristan 2,  
1000 Ljubljana, SLOVENIA  
[mojca.sasek@uirs.si](mailto:mojca.sasek@uirs.si)

**Abstract.** Understanding and evaluating of “sustainable development of cities” is important for all actors which are interested in the evolution of the cities. It includes also broader public and is particularly important for young generations. In the paper we present the system of indicators, with which we can monitor and estimate urban conditions in the present and planned city. The system of indicators could become an appropriate support for the evaluation of sustainable conditions, for the planning operations, and for decision-making at different levels. It could be used too as a basis of experimental models in educational processes focused in the environmental problems.

**Keywords:** measuring sustainability, system of indicators, sustainable development, urban development, simulation.

### 1. Introduction

Understanding and evaluating of “sustainable development of cities” is important for all actors which are interested in the evolution of the cities. It includes also broader public and is particularly important for young generations. In the paper we present the system of indicators, with which we can monitor and estimate urban conditions in the present and planned city.

The improvement of urban quality is one of the primary goals of city planning and design. Due to the rapid growth of urbanised areas, many pollution problems have arisen with negative feedback on the quality of life in cities and their gravitational areas. Cities and other settlements are the key factors in the strategy of sustainable development which incorporates the reduction of environmental pollution, reasonable management of space and natural resources, rational use of energy, careful management of waste, etc. In addition to environmental protection including the preservation of historical, cultural, and

natural heritage, the term "sustainable development" comprises substantial values of the urban environment, whose aim is to ensure the quality of both physiological and psychological spheres of living.

Settlement development policies are closely connected to social-economic development policies. The physical space reflects the development decisions in all areas of life and work. For this purpose all questions with regard to spatial planning should be solved comprehensively, in connection with economic and social development, and take into consideration natural potentials and limitations, observing the principles for sustainable development. This means harmonisation of economic and social development tendencies paralleled by the protection and improvement of the environment. It requires the joining of environmental protection with economic and other policies and with decision making in all areas of activities. Concerning settlement policies, the sustainable viewpoint is extremely important, as the activities that are connected with settlement processes are the cause of the biggest changes and burdens on the environment.

When dealing with the advancement and execution of these policies we come across many problems and contradictions that need solving. The term sustainable development itself contains the contradiction, as it combines both the development and the protection viewpoint. We have ascertained that the sustainable balance will not be reached, if we do not reach higher economic and social dynamics in urban and rural areas (offer employment possibilities, economic development, social care) and also better environmental protection. It is not always easy to link the development and the protection strategies.

Some other contradictions we meet in the advancement of sustainable planning:

Market mechanisms (with consideration of only short term profits) work often against planning, in particular against the sustainable orientation;

- Local actions are not always in accordance with national goals;
- Sectional work organisation can work against inter-sectional activity;
- Citizens have opposing requirements that on one side include the spatial decision making

influence and on the other behaviour as users; the so-called paradox of the user against the citizen;

- Certain interests of the community which are in opposition with the individual interests (known symptom at the problematic objects, i.e. not in my back yard) etc.

The challenge of sustainable development in the long run requires big changes in our thinking and behaviour, in social life and in the economy. Because of the rapid changes in the environment and accumulation of other economic and social problems we have to act and reorganise quickly. Apart from the development of firm mid and long-term principles we can gain a lot in the short-term by making smaller steps in the right direction. Successful execution of these principles depends mainly on the ability to connect and form partnerships at all government levels, in the private sector, professional institutions non-governmental organisations, in the wider society and also on the active role played by the local community. Continuous monitoring and evaluation of the policy results, the situation and direction of development are important for correct decision making. We have decided on sustainability as the goal and we need to know how to measure it. For this purpose we first need to set up the basic parameters of sustainable development and establish a system of indicators for measuring.

## **2. System of indicators for measuring sustainability in urban areas**

Urban areas have a crucial influence on sustainable development; they are continuously growing and changing the image of the Earth with densely populated parts, industrial areas and extensive transport and road networks. Activities in the city have a negative influence on the environment i.e. air, soil, water, waste, audio and visual pollution. These problems indirectly affect the human habitat, people's health and quality of life. Within the city organism we wish to gain environmental, social and economic balance, so-called internal sustainable balance. We have to consider the influence on the city from the surroundings and the outgoing city influence, on the countryside hinterland and the region.

Sustainable city development means that the city together with the surrounding countryside (gravitational area, region) achieves ecological

and social-economic balance. The urban system that has not achieved this balance has fallen into crisis and this reflects the negative consequences of our industrial-technological society. The term sustainability embraces the care for natural sources and environment, and also cultural and human demands. The social balance (for example negative influence of unemployment), human and culturally rich environment and psychological satisfaction are also important. All parameters together present sustainable city development, that is a composite of the particular balances.

The presented system of indicators bases on several existing researches. The selection has been upgraded and partly changed. The directions are given considering the European New Charter of Athens [1]. The first and the second sets include environmental and socio-economic indicators, prepared on the basis of a study of The European Foundation from Dublin [2]. The third set comprises physical space indicators and has taken into consideration the research from The Hague [3]. The fourth set includes urban design indicators that took into consideration the design principles [4].

Sustainable urban indicators represent a tool for measuring sustainable development and assessing the foreseen changes. The first task is the creation of a database, the next one the formation of indicators in accordance with previously set goals. However, we must be aware of the fact that indicators can offer only a limited picture of spatial conditions rather than the complex realities, because it is not possible to quantify all the elements that have impact on the environment. It is therefore necessary to select the key indicators. They should be directly obtained, they must be clear, simple, scientifically sound, verifiable and reproducible; transparency is a must. For holistic observation it was necessary to join various disciplines and fragmented knowledge. To put such system into practice requires interdisciplinary work, co-operation of professionals from various domains where all contribute their own data and adjust them to suit the others.

The formation of indicators and the system for measuring sustainable development depend upon the level of treatment (national, regional, local, etc.), upon the conditions, processes, and problems occurring in the environment, upon the developmental policy, and the set goals. This is

why indicators should be changed and upgraded. The formation of indicators is an unfinished process closely dependent upon actual needs. Each city is unique and has to find its individual paths towards sustainability. Consequently, the chosen system has been devised enough flexible to allow necessary modifications and extensions.

Whilst evaluating the meaning of individual indicators we tried to establish a balanced evaluation on the city level. Individual indicators have different meanings depending on the level; city level, quarter, neighbourhood (local level). For this purpose we introduce various evaluations for the particular level.

### 3. Four sets of indicators

Indicators should demonstrate which city parts have either a positive or negative direction of development, in view of the set goals. The system of indicators, like urban sustainable strategies, consists of four groups: environment, social-economic, physical space and urban design. The result is a total index of sustainability, and it indicates a complex evaluation.

- **First set: Environmental indicators**

- Global climate,
- Air quality,
- Rain acidity,
- Ecosystem codification,
- Urban mobility,
- Waste management,
- Energy consumption,
- Water consumption,
- Indicators of interference (noise, smells, etc)
- Other.

- **Second set: Social-economic indicators**

- Social equity - legality,
- Accommodation conditions,
- Urban safety,
- Economic and social balance (for example: income, age)
- Citizen participation (in city management)

- Other.
- **Third set: Indicators of physical space**
  - The urban substance situation (age of buildings, state of preservation, facilities, etc)
  - Urban infrastructure (roads, sewage, water, electricity, gas, telephone, etc)
  - Size and quality of the open area (squares, streets, embankments, etc)
  - Green areas (size, quality and accessibility)
  - Equipment of centres,
  - Distance from the centres,
  - Other.
- **Fourth set: The urban design indicators for the city:**



Figure 1: Total sustainability index - case of Ljubljana city

- Urban scale and pattern for reaching the human environment: taking into account largeness, height of a building in relation to its surroundings, proportion of mass, aesthetic dimensions,
  - Harmony (compatibility) of objects and places with regards to topography and between themselves,
  - Perception aspects of orientation (concept of streets, objects placing and relation of their masses, visual openness, views),
  - Accessibility, clarity of orientation in particular for pedestrian,

- Activity, suitability of activities, variety of programs, street life and life on the square (shops, bars, walking, passageways)
  - Variety of urban areas, identity and individuality in the shaping of individual urban structures and places,
  - Appearance and proportion of open spaces to built-up areas,
  - Variety of architectural elements in the identification sense, visual and symbolic abundance (style, composition, standard)
- Pedestrian areas: design and equipment (design of squares, streets, greenery, urban equipment)
- Aesthetic environmental qualities: architectural issues, visual and symbolic richness, visually pleasing details,
- Other.

Each single indicator was separately defined and the method of measuring described. A table of all indicators was prepared together with evaluation, scores, and weighting factors that could be taken into consideration either for single indicators or for the whole group. The computer model EKO was developed and devised for the calculation and demonstration of significant factors that have impact upon sustainable urban development. The structure has been designed hierarchically and comprises a system of indicator trees. Ljubljana has been shown as a detailed case study where we have partly used the available and partly some hypothetical data.

#### 4. Conclusions

Towns, as the most important human settlements, are the main originators of development, for they represent the basis for economic and social interrelations. At the same time, they are great consumers of space and natural resources, and are polluters of the environment. Therefore, we have tried to define which characteristics of the urban way of life and which components in the city structure have the strongest impact, either positive or negative, on the process of sustainable development. The basic idea of the working hypothesis was that we could prepare a system of measuring sustainability, which would become a tool for monitoring and assessing the space and planned operations, only by studying the parameters of sustainable development.

The term "sustainable development of towns" has been often used inappropriately as a synonym for environmental protection. In fact, it encompasses more important qualities of the urban and living environment. We expect that the results of the research will bring about a changed and more integrated attitude towards the planning of towns and will be a useful instrument in decision-making. The system of indicators, together with the computer-aided EKO model, for which we have set the basis in the research, should be further developed and upgraded. Basically adequate databases must be prepared. With such improvements, the system of indicators could become an appropriate support for the evaluation of sustainable conditions, for planning operations in the urban environment, and for decision-making at different levels. But, only a sheer statement of indicators and their total index of sustainability cannot contribute to urban quality if there is no political will for a change for the better.

We have established that in Slovenia the majority of the sustainable domains are still neither adequately analysed nor interpreted, although various institutions have gathered numerous data. This is the reason why it is necessary, in the first place, to create an adequate database, preferably as a part of a joint computer aided database for monitoring the actual state and the level of urbanization in Slovenia. Such a database should be accessible to all those experts that are engaged in the field of spatial planning and management and to the broader public as well.

Certainly each place and city needs to be analysed with regards to their regional and local characteristics and the model should be adapted to the place and time. Continuous monitoring of the activities and the conditions of the environment, sources of its endangerment and trends in urban development, that form the basis for decision making, are becoming one of the main developmental-existential tasks for future decades.

## 5. References

- [1] New Charter of Athens 2003. The European Council of Town Planners' Vision for Cities in the 21st Century. UNESCO SHS. Lisbon 2003.
  - [2] Mega V. Urban Sustainability Indicators for Europe, Proceedings of the International Conference The European City - Sustaining Urban Quality. Copenhagen 1995.
  - [3] Adriaanse A. Environmental Policy Performance Indicators, Dutch Ministry of Housing, Physical Planning and Environment, The Hague 1993.
  - [4] Sasek Divjak M, Implementation of Habitat Agenda in Slovenia. Urban Planning Institute of the Republic of Slovenia, Ljubljana 2003.
  - [5] Li, G.; Weng, Q., Measuring the quality of life in city of Indianapolis by integration of remote sensing and census data. Int. Journal of Remote Sensing, Volume 28, Number 2, 2007, Taylor and Francis Ltd.
- 
-

## High Volume Fly Ash Concrete: An Innovative, Cost Effective and Eco-Friendly Revolution in Construction Industry

S.K. Chaudhary

Asst Engineer, Road Construction Dept.,  
Patna, INDIA

**Abstract.** Deterioration of Concrete structures in marine environment has been a matter of great concern for engineering fraternity throughout the world. In an effort to improve the performance of Concrete structure Investigations have been made to develop durable, cost effective and eco friendly concrete composite using fly ash in a specified percentage (by weight) in place of cement. Study of behaviour of plain concrete and high volume fly ash concrete having fly-ash in high volume exposed to different aggressive environment (5% H<sub>2</sub>SO<sub>4</sub> Solution, 5% HCL Solution, 10% (NH<sub>4</sub>)<sub>2</sub>SO<sub>4</sub> Solution and 10% NaOH Solution) for 28 days revealed that High Volume fly ash concrete was more durable than ordinary Portland cement concrete. A specified percentage replacement of cement (by weight) by fly ash makes the concrete impervious and enhances the compressive strength and durability of concrete exposed to different aggressive environment. The strength of PCC exposed to aggressive medium reduced significantly. This reduction in strength was mainly due to expansive salt formation and weakening of bonds. The formation of expansive salt also resulted in cementitious properties and loss of weight. The investigations were carried out to establish correlation between durability and deterioration in properties for both undamaged concrete and concrete damaged by chemical attack.

### Introduction

Concrete is the most widely used man made construction material in the world. Though plain cement concrete is quite strong mechanically, it suffers from several drawbacks such as low tensile strength, permeability to liquids and consequent corrosion of reinforcement, susceptibility to chemical attack and low durability particularly in the coastal region and in aggressive environment where the structure is

subjected to significant distress or deterioration within their expected life span. The emphasis of worldwide research has been to seek ways of improving performance, wide and economical use of these materials by development in materials and construction technology. The improvement in performance of cement concrete has been achieved by producing new concrete composite by adding fly ash in high volume to cement concrete.

Huge amount of fly ash generated at thermal power station and other industrial plant posing a great environmental problem has led to a world wide search for effective utilization and disposal of this waste product of great nuisance value. In India more than 65 major coal based thermal power plant with an installed capacity of 110 million ton of fly ash per year. Its threat to environment, ecology and human health is well documented and a lot of research is taking place to effectively transform this waste into a resource. With this view point, the author has made an attempt to utilize fly ash in high volume (50%) to concrete in place of cement to improve its strength, durability and performance and at the same time to make it cost effective and eco-friendly also.

High volume fly-ash concrete (HVFC) is an approach to maximize the fly-ash input in concrete. Briefly this type of concrete has very low water to cementitious ratio, very low water content and incorporates about 50% of fly ash (ACTM Class F, low calcium fly ash). In view of the low-water content, high range water reducer (super plasticizer) are used. The HVFC has all attributes of high performance concrete namely excellent mechanical properties, low permeability and superior durability.

HVFC is a composite material consisting of fly ash in high volume, coarse aggregate, fine aggregate and water. It possesses several advantages such as attaining high compressive strength, imperviousness, better resistance to fatigue and good resistance to acid and sea water. The main focus of this paper is to highlight results of study carried out on the durability properties of concrete when a specified percentage (by wt) of fly ash is used to replace cement in conjunction with strength development.

## Materials

The materials used in this investigation were ordinary Portland cement of 43 grade conforming to IS 12269:1987, fine aggregate and coarse aggregate. Fine aggregate was washed river sand with fineness modulus 2.57. Its uniformity co-efficient was 1.9. The coarse aggregate was crushed stone aggregates of size 20mm and down having fineness modulus 6.24. Fifty percent of fly ash (class-F type having surface area of 16000 cm<sup>2</sup>/gm) was used in this investigation. To make this concrete **high performance and self compacting** in nature Naphthalene based Superplasticiser conforming to bureau of Indian standard, and viscosity modifying agent were used.

## Mix design

Mix design of M 30 strength was prepared for all the test. This mix design was based on IS code method. HVFC was prepared by addition of 50% fly ash (by weight) in place of cement.

## Experimental investigation

Twelve PCC cubes of M 30 strength and set of three concrete cubes with different fly-ash content (viz. 10%,20%,30%, 40%, 50% by weight of cement) of 150 mm size were cast. These cubes were as per mix design. PCC and HVFC cubes were cured in water for 28 days. PCC and HVFC (each of 3 sets) having fly ash 50% (by weight) in place of cement were immersed in 5% H<sub>2</sub>SO<sub>4</sub> solution, 5% HCL solution, 10% (NH<sub>4</sub>)<sub>2</sub> SO<sub>4</sub> solution and 10% NaOH solution for 28 days. Compressive strength of PCC and HVFC were determined before and after exposure to chemicals.

To study the behaviour of PCC and HVFC exposed to aggressive environment, following tests were carried out:

1. Weight Loss Test at an interval of 7 days
2. Compressive strength test
3. pH test.
4. Carbonation test
5. Ultrasonic pulse velocity test

Table-1 shows Chemical Analysis of fly-ash obtained from Durgapur Steel Plant (West Bengal). Table-2 shows designation of Mix. Table 3 shows compressive strength of HVFC having different fly-ash content. Compressive

strength of PCC and HVFC cubes after 28 days exposure are tabulated in Table-4. Weight loss of both types of concrete after exposure to corrosive environment is presented in Table-5. Table-6 shows carbonation depth, pH Value and results of UPV for both concrete.

Results of both types of concrete were compared. The deterioration and performance were correlated.

S.No.	Composition	Percentage
1	SiO <sub>2</sub>	60.40
2	Al <sub>2</sub> O <sub>3</sub>	24.60
3	Fe <sub>2</sub> O <sub>3</sub>	9.60
4	CaO	2.10
5	MgO	0.40
6	SO <sub>3</sub>	0.35
7	Loss on ignition	2.07
8	Surface Area (Cm <sup>2</sup> /gm)	2998

Table 1. Chemical Analysis of Fly Ash

Designation	Percentage of	
	Fly Ash	Cement
M-0	0	100
M-10	10	90
M-20	20	80
M-30	30	70
M-40	40	60
M-50	50	50

Table 2. Designation of Mix

Fly ash by Weight of Cement	Average Cube Compressive Strength (N/mm <sup>2</sup> )
10	48.5
20	52.7
30	47.75
40	46.50
50	45.25

Table 3. Average Cube Compressive Strength of Fly Ash Concrete



Chemicals	Average cube Compressive strength of PCC (N/mm <sup>2</sup> )	Average cube compressive strength of HVFC (N/mm <sup>2</sup> )
5% H <sub>2</sub> SO <sub>4</sub> solution	10.5	40.20
5% HCL solution	15.5	39.35
10% (NH <sub>4</sub> ) <sub>2</sub> SO <sub>4</sub> solution	21.25	42.60
10% NaOH solution	32.65	45.10

**Table 4. Comparative Compressive Strength of PCC and HVFC after 28 days exposure of Chemicals**

Chemicals	Type of Concrete	Wt. Loss (%) after			
		7 days	14 days	21 days	28 days
5% H <sub>2</sub> SO <sub>4</sub> solution,	Plain	6.10	10.50	14.50	18.98
	HVF C	-	0.05	0.15	0.20
5% HCL solution,	Plain	5.40	10.20	13.10	15.40
	HVF C	-	0.11	0.16	0.25
10% (NH <sub>4</sub> ) <sub>2</sub> SO <sub>4</sub> solution	Plain	1.90	3.20	4.70	6.30
	HVF C	-	0.04	0.10	0.15
10% NaOH solution	Plain	0.70	1.50	1.70	1.87
	HVF C	-	-	-	-

**Table 5. Comparative Weight Loss of PCC and HVFC After exposure of Chemicals**

Chemicals	Types of Concrete	Depth of Carbonation (mm)	PH	UPV (Km/sec)
5% H <sub>2</sub> SO <sub>4</sub> solution	Plain	7.3	2.0	0.95
	HVFC	0.2	11.8	3.95
5% HCL solution	Plain	5.2	4.0	1.70
	HVFC	0.1	12.2	4.1
10% (NH <sub>4</sub> ) <sub>2</sub> SO <sub>4</sub> solution	Plain	3.0	8.5	2.11
	HVFC	-	12.5	4.25
10% NaOH solution	Plain	-	11.5	4.10
	HVFC	-	12.5	4.45

**TABLE 6. Comparative Statement of Depth of Carbonation, pH and UPV of PCC and HVFC after 28 Days Exposure of Chemicals**

## Discussion and results

### Visual Examination

There was no appreciable difference in colour for PCC and HVFC except in HCL and NaOH solution. The colour of NaOH solution containing HVFC cubes became yellowish and a whitish deposit was deposited on the top surface of cubes. The colour of concrete cubes (plain and HVFC) in HCL solution became brownish. But when PCC were immersed in NaOH solution, no change in colour was observed.

After 28 days of exposure it was observed that aggregates of PCC in H<sub>2</sub>SO<sub>4</sub>, HCL and (NH<sub>4</sub>)<sub>2</sub>SO<sub>4</sub> solution were more visible. Aggregates of HVFC in H<sub>2</sub>SO<sub>4</sub>, HCL and (NH<sub>4</sub>)<sub>2</sub>SO<sub>4</sub> solution were slightly visible. It was due to washing out of cement paste. But in NaOH solution no such observation was made because cement paste was not washed out due to alkaline environment. Deterioration in H<sub>2</sub>SO<sub>4</sub>, medium was more than any other medium for both type of concrete.

### Weight Loss Test

The weight of both types of concrete cubes was taken before immersion into solution. The weight loss was found at an interval of 7 days. The loss in weight of PCC and HVFC cubes is shown in Table-5. It was seen that there is an improvement in the resistance to corrosive attack with incorporation of fly ash.

It can be seen from table-5 that were was negligible loss in weight for HVFC in H<sub>2</sub>SO<sub>4</sub> medium, while for PCC it is maximum up to 18.98%. This is likely due to formation of voluminous calcium sulphoaluminate (ettringite). Loss in weight of PCC in HCL medium is maximum upto 15.4%. This is likely due to formation of calcium chloroaluminate. Similarly weight loss in (NH<sub>4</sub>)<sub>2</sub>SO<sub>4</sub> medium for PCC is maximum upto 6.3%. This is due to formation of less voluminous calcium sulphoaluminate.

But in NaOH medium for PCC, weight loss was only up to 1.87%, which is very less. This is due to strong bond, non-leaching of lime and alkaline environment which do not promote deterioration of concrete. Hence PCC is most durable in NaOH medium. Negligible weight loss reported in the table indicates improved dimensional stability and better integrity of concrete with the addition of fly ash.

### Compressive Strength Test

The compressive strength of concrete cubes was determined as per IS 516:1959 at a loading rate of 140 kg/cm<sup>2</sup>/min on 200 ton compression testing machine.

It was observed from table-4 and fig-1 that the compressive strength of PCC and HVFC shows less value in H<sub>2</sub>SO<sub>4</sub> medium than all other medium. It was also observed that PCC deteriorate more than HVFC in all medium.

### Carbonation and pH Test

Carbonation is the effect of CO<sub>2</sub> from atmosphere reacting with alkaline component Ca(OH)<sub>2</sub> in concrete in presence of moisture thereby converting this Ca(OH)<sub>2</sub> to CaCO<sub>3</sub>. This can be detected by adding phenolphthalein on different depth of concrete and observing the colour profile. Pink colour shows the effect of carbonation while colourless profile shows no carbonation.

From table-6 and fig-2 it can be observed that the depth of carbonation is more for PCC in H<sub>2</sub>SO<sub>4</sub> medium while it is least for HVFC in HCL medium. In (NH<sub>4</sub>)<sub>2</sub>SO<sub>4</sub> and NaOH medium for HVFC, no carbonation was observed.

From table-6 and fig-3 it is observed that in every medium, pH for HVFC is more than plain concrete. It was also observed that in NaOH medium this value is maximum for HVFC while minimum for plain concrete in H<sub>2</sub>SO<sub>4</sub> medium.

### Ultrasonic Pulse Velocity Test

This is a well recognized non destructive test method to assess the homogeneity and integrity of concrete exposed to aggressive environment. This method basically involves the measurement of velocity of electronic pulse passing through concrete medium from a transmitting transducer to a receiving transducer. The test was performed with the help of digital ultrasonic concrete tester. Time was recorded in microseconds. The thickness of concrete specimen divided by the time gives pulse velocity.

From table-6 and fig-4 it can be seen that UPV for PCC is less than that of HVFC in every medium. In NaOH medium its value is 4.10km/sec for PCC and 4.45 km/sec for HVFC. Lower velocity indicates more transit time thereby more chemical attack and integrity of concrete has disturbed more. It may be due to expansive salt formation, presence of voids and weakening of bonds. UPV study reveals the fact that PCC has deteriorated more than HVFC in

every medium. It is also clear from study that PCC has deteriorated more in H<sub>2</sub>SO<sub>4</sub> medium.

### Potential of utilisation of hvfc in the housing sector

High volume fly ash concrete can be used in foundation and concrete block masonry. For example a low cost house having a plinth area of 249 square feet consisting of living room, a Hall, Kitchen, bath and verandah has been considered and the total consumption of fly ash has been estimated and reported in table-7.

S.No	Particulars	Quantity	Fly ash per cum	Total Quantity of fly ash
1.	Cement concrete in foundation	1.44 cum	400Kg	576Kg
2.	Concrete block masonry in foundation	10.61cu m	500Kg	5305 Kg
			<b>Total</b>	<b>5881 Kg</b>

Table 7. Consumption of Fly ash in Low Cost Housing

India needs to construct about 40 millions dwelling unit in order to meet the demand because of shortage of housing. Assuming that 50% of the above dwelling unit use HVFC, the total requirement of fly ash can be estimated as following:

$$\text{No. of House} = 20 \text{ Million}$$

$$\text{Fly ash required} = 20 \times 5881 = 117.62 \text{ Million Ton}$$

The present generation of fly ash is 110 Million ton in India. Therefore even if 50% of total housing stock uses HVFC in foundation and concrete masonry block in foundation only, there is going to be shortage of fly ash. Apart from low cost housing, HVFC can be used in column, beam of multistoried building, bridges, road etc. However, different uses fly ash in low volume are in bricks, doors and windows, roofing, paint etc. which have already been experimented by author.

### Economic aspect

On the basis of manufacturing cost Utilization of HVFC having Self compacting property has potential to reduce the cost of cement concrete having similar compressive strength by nearly 30% as per Author's analysis. The reduction in cost is due to reduction in cement consumption, use of by product i.e fly ash, saving in electricity, saving in labour cost related to compaction work and increase in productivity.

### Environmental aspect

Utilization of HVFC minimizes the CO<sub>2</sub> emission problem to the extent of its proportion of cement. Utilization of HVFC in low cost housing will also reduce CO<sub>2</sub> load on atmosphere by 102 million ton. Similarly, Utilization of HVFC in PSC Sleeper will reduce CO<sub>2</sub> load on atmosphere by 23382 ton per year as per author's analysis. This has a lot of significance to the agenda of climate change summits, particularly in the context of India's consent to sign the KYOTO protocol. This facilitates our participation in clean development mechanism (CDM) that may earn 3 to 10 dollars for every ton of CO<sub>2</sub> abated under carbon Credit. Such trading mechanism is a win-win situation for all of us for promoting this clean technology.

As we witness the draught in recent years in almost major part of the country, the culprit is nothing but the climate changes induced by human activities resulting in the phenomena of El Nino and La Nino. All of us are going to encounter such a future whereby inheriting millions worth of property becomes redundant against the basic needs of sound and safe living. This is where our commitment to protect the ecology has a lot of significance towards sustainable development. Utilisation of high volume fly ash concrete is one major task in such a sound technological march.

### Conclusion

1. HVFC is a cost effective, durable, high strength and eco-friendly material in Aggressive Environment.

2. Since this concrete is high performance and self compacting in nature (i.e no noise pollution), it can be termed as a silent revolution in the field of construction Technology.

3. It is an energy conservation technique in aggressive environment as it eliminates electricity requirement for compaction of concrete and provide ample opportunity to use by product material such as fly ash.

4. In every medium HVFC shows better performance than PCC.

5. HVFC is most durable in NaOH medium.

6. The compressive strength with 50% fly ash as an admixture has shown improvement over conventional concrete.

7. The loss in strength of PCC was due to expansive salt formation and weakening of bonds.

8. Loss of cementitious property of PCC in H<sub>2</sub>SO<sub>4</sub> medium was maximum and it was minimum in NaOH medium.

9. Lower ultrasonic pulse velocity indicates higher deterioration.

10. UPV test is a quick and scientific method to assess the performance of concrete exposed to aggressive environment.

### REFERENCES

- [1] Neville A.M., "Properties of concrete", 3<sup>rd</sup> edition, Pitman publishing company London 1989.
- [2] Banerjee S.N., "An introduction to corrosion science and its inhibition", Oxanion Press Pvt. Ltd., 1987.
- [3] Chaudhary S.K., "Ultrasonic Pulse Velocity Test for corrosivity of concrete structure", Indian Railway Journal, August 1999, pp. 17-18.
- [4] Shetty M.S., 'Concrete Technology', S. Chand & Company Ltd., 1997
- [5] Gambhir M.L., 'Concrete Technology', Tata McGraw-Hill Publishing Company Ltd., New Delhi, 1956.
- [6] Mehta, P.K., Concrete Structure, Properties and Materials, Prentice Hall.Inc., New Jersey, 1986.
- [7] Lawrence, C.D., Sulphate attack on concrete, Mag. Concr. Res.V.42, 1990, pp.249-264.
- [8] Wood, H., Durability of Concrete Construction, A.C.I. Mater. Jour., 1968, Monogram No.4.
- [9] Singhal. D, Agrawal.R and Nautiyal B.D, 'Chloride resistance of ordinary portland cement concrete" jour of institution of engineers, Vol. 79 August 1998, pp 63-66.
- [10] Mani.K, Annamalai.S., Chellapam.A, Srinivas.P, Kalyansundaram.P, "An approach to investigation of corrosion affected concrete structure and some data from case studies, "Indian concrete journal, vol.72, No.6, June 1998, pp287-295.
- [11] Code of practice for plain and reinforced concrete, IS: 456-2000, Bureau of Indian Standard, New Delhi.
- [12] IS: 269-1976 specification for ordinary and low heat portland cement: B.I.S, New Delhi.

- [13] IS: 383-1970, specification for coarse and fine aggregate from material sources for concrete, BIS, New Delhi.
- [14] IS: 516-1959, Method for test of strength of concrete, BIS, New Delhi.
- [15] Buenfiled N.R and Newman J.B “The permeability of concrete in Marine environment; Magazine of concrete research Vol. 36, 1984, pp 67-80.
- [16] Kayyali O.A, ‘Strength and porosity of portland cement paste subjected to chloride penetration, journal of materials in Civil. Engg. ASCE, Vol.1, 1989, pp 10-19.
- [17] Ouyang, C., Nani.A and Chang W.F., Internal and External Sources of Sulphate Ions in Portland Cement Mortar: Two Types of Chemical Attack, Cem. Concr. Res., V.18, 1988, pp 699-709.

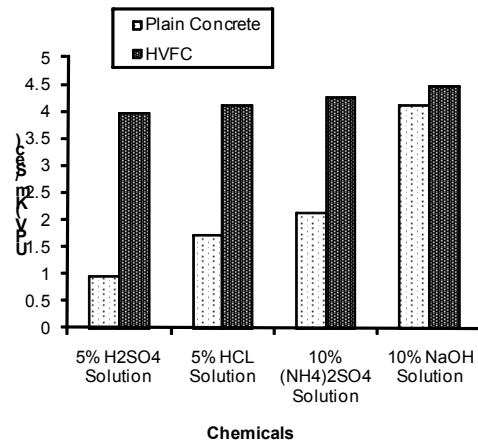


Fig.4 UPV Vs Chemicals

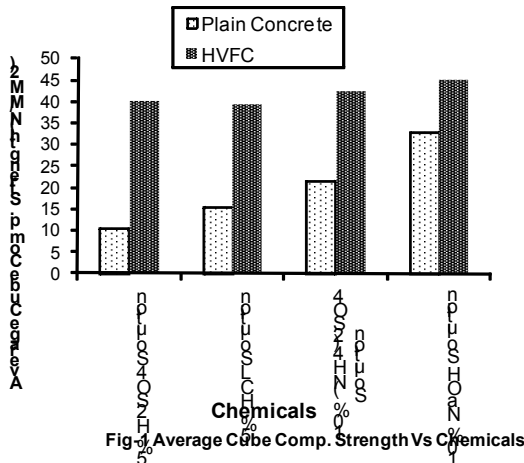


Fig.3 Average Cube Comp. Strength Vs Chemicals

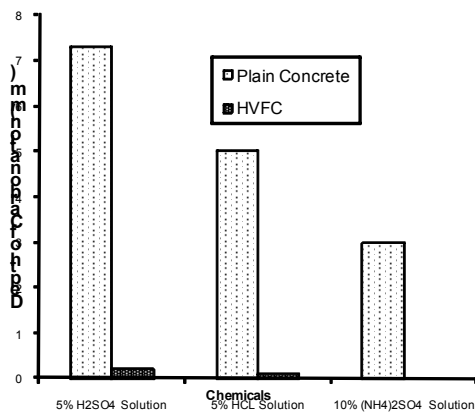


Fig-2 Depth of Carbonation Vs Chemicals

## Family Hands-on Activities in Science and Technology Education for All: Gifted and Ungifted, Children and Adults

J. Trna and E. Trnova  
Masaryk University, Faculty of Education,  
Porici 7, 60300 Brno, CZECH REPUBLIC  
trna@ped.muni.cz

**Abstract.** Family education is an innovative educational method in science for gifted and ungifted children and adults. Family science education is defined as expanding science knowledge and skills from the school setting to home. These hands-on activities require simple equipment which can be found in most homes. From the pedagogical constructivist point of view it is important to select educational activities suitable for families. These are daily and safe living. The combination of phenomena on the human body and hands-on experiments results in motivation for all. Family hands-on activities can help identify and develop students gifted in science.

**Keywords:** daily and safe living, family science education, hands-on experiments, motivation in science education.

### 1. Family science education and lifelong education

At the present time, science education is becoming lifelong education. The reason is the rapidly growing number of new applications and the expanding knowledge in science. The fact that science knowledge gained in school does not satisfy the necessities of a human lifetime anymore could be a source of negative attitudes towards science. Many adults are gradually losing touch with current science knowledge and they sometimes do not understand how new appliances work, therefore they frequently do not use them. This negative attitude might be transferred from parents and grandparents to their children who subsequently feel the lack of motivation to study science. So a pedagogical research problem focused on how to reverse this negative trend appeared.

Our research and experience brought us to develop an educational method called family science education (FSE). This type of education is implemented by the transfer of knowledge and skills from the school setting to families. Students who do FSE at home have the potential to inspire their siblings, parents and grandparents. We believe that FSE is an efficient educational method, which nevertheless requires several conditions to be met. The main one is interesting educational content that is based on using relevant knowledge and skills from a student's everyday family life.

FSE could become a significant and effective part of parents' and grandparents' lifelong education. As it is a by-product of formal school education, it does not demand any additional financial costs.

Generational barriers to education result from the considerable acceleration of science knowledge as well as school education. Parents and grandparents are often unable to help students with homework, because they do not understand the educational content and technology. The older generation may come across new knowledge and products they cannot use or manipulate (e.g. ICT). Then complications, even insuperable obstacles may arise in the individual's life. FSE may play a part in the lifelong education of older generations by exposing them to science information that could be beneficial.

### 2. Family science education and motivation of students

A crucial problem of contemporary science education is how to motivate students. Research shows that an overwhelming segment of the young population takes a negative or neutral attitude toward science. Science teachers are looking for motivational techniques which would help to eliminate a negative attitude toward science. Our research has produced findings concerning the use of cognitive motivational techniques [4]. We can increase the motivation with a combination of these cognitive techniques. Cognitive motivation has a positive advantage, but using just this type of motivation is not enough.

It is not possible to omit social and achievement motivation that are formed in the social and family environment [1]. The key

factor is a student's family, especially during the primary school age. If a student is surrounded with a family who has a positive attitude toward science, this environment will affect the student's inclination toward science education. This student may be appreciated for good school results in science, and the parents, for example could buy the child science toys, go on science trips; or enrol the child in informal science activities.

The question is how to influence families in order to motivate students positively. It seems that a suitable method might be FSE in which students participate. These students help transfer science knowledge to their families who can subsequently develop a positive attitude toward science. It is essential to find the ideal factors in science education that could be easily used in a family setting. Our pilot research shows the existence of suitable educational contents for FSE, especially knowledge and skills concerning daily and safe living.

### **3. Family science education and hands-on activities**

Hands-on activities applied to science education have various attributes which can be used in FSE. The most important attributes are:

- Use of objects and materials of daily life (they are commonly found in homes)
- Low-cost objects and materials of everyday life (as they do not increase families' financial costs, they are accessible to everyone)
- Easy implementation (activities do not require special knowledge and skills – they can be accomplished by most family members)
- Transparency of natural phenomena (natural phenomenon is easily observable and comprehensible to a layman)

Given the reasons stated above, hands-on activities are seen as suitable for FSE. From the motivation point of view, increasing the effect of motivational techniques and methods of their combination is vital. There is a possibility of associating hands-on activities with the educational contents appropriate for FSE. On that account we have applied hands-on activities of the human organism in our research. The first research results are promising and they raise

hopes that either lifelong adult education or backward motivational effect on a student will work efficiently. Next we will focus on the theme of science hands-on activities in more detail.

### **4. Hands-on activities and daily and safe living in family science education**

Daily and safe living is appropriate content used in FSE. These contents are [5]:

- The human organism: Students are acquainted with the parameters of the human body which can be expressed with the aid of quantities, units and laws. Also external conditions are very important for preservation of vital functions of the human organism including health.
- Home, entertainment, sports etc: Students can be motivated by explanation of basic features in everyday life such as heat and light sources, means of transport, audiovisual techniques, chemical agents, domestic plants and animals etc. Information on economical and ecological behaviour in everyday living is growing more and more important.
- Safety risks: Protection against negative extraneous influences on the human organism and information on safe behaviour in transport, at work etc.

For students and adults the human organism is an interesting object. An important advantage of teaching and learning about the human organism is that teaching aids are not needed because everyone has a body.

Understanding human body measurement is a very practical approach to the prevention and diagnosis of certain diseases or risks. The important theme is life protection against dangerous influences, which include the fast change of atmospheric pressure and speed, effects of forces, temperature fluctuations, radiation etc.

Every student can be motivated by the combination of hands-on activities and a human body experimenting and measuring within the educational content. With the assistance of hands-on activities with our body we can also diagnose potential health risks. Prevention of at-risk factors is based on human body measurements.

Many human body parameters can be measured by students and adults such as temperature, weight, blood pressure, body mass index etc. We realized the research of educational efficiency of these activities in FSE.

#### 4.1. Flat foot

We used the measurement of flat feet as the educational content for our research [6]. The research of the effectiveness of FES was carried out twice (in 2006 and 2009). One hundred students in the fourth grade in primary science lessons were taught how to measure flat feet.

Students' theoretical background:

The foot structure is very important for various movement conditions of the body. The most known disorder of flat feet is caused by fallen arches. Inappropriate footwear is a large contribution to this disorder. That's why the length and width of the foot is important when buying the correct shoes.

Students' hands-on activity:

Paint the sole of the foot with water (oil, ink etc.) and step on suction paper. Use a ruler to measure the widest ( $w_1$ ) and narrowest part ( $w_2$ ) of the footprint (Figure 1). Calculate  $I = w_2 / w_1$ . Evaluate results using the Table 1.

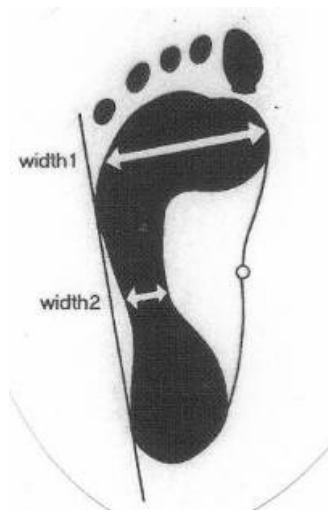


Figure 1. Flat foot

Table 1. Flat foot

$I = w_2 / w_1$	
normal foot	$I = \text{less } 0,45$
start to be flat	$I = 0,45$
flat foot	$I = \text{more } 0,45$

A questionnaire was distributed to the parents of students after two weeks. Parents were asked to answer four questions concerning the measuring for flat feet. The questions, the percentage of positive answers and the number of questionnaires received back is in Table 2.

Table 2. Flat foot - research results

		Percentage of answer: YES (2006):	Percentage of answer: YES (2009):	Number of received questionnaires (2006/2009):
1	Do you know a simple method of measuring flat feet?	68	65	75/80
2	Did you receive this method from your children?	60	62	75/80
3	Have you measured your foot using this method	24	30	75/80
4	Have you found latent flat feet in your family?	4	5	75/80

The research results verify the effectiveness of FSE in the primary school science by the use of the combination of hands-on activities and human body measurement.

#### 4.2. Obesity

The measuring of obesity was used as the educational content for our next research on the effectiveness of FSE in 2008. The obesity diagnosis is also good human body measurement content for FSE. One hundred students of the eighth grade in lower secondary science lessons were taught how to measure for obesity.

Students' theoretical background:

Body weight is defined as an essential parameter that helps us to find out the state of health and

even predict health complications in the future. The often used parameter for body weight assessing is body mass index (BMI). The latest investigations verify the importance of the distribution of fat (types of obesity). Fat distribution is possible to find by means of waist and hip circumference which is more predictive of cardio respiratory risks than BMI. The WHR index is the ratio of these two parameters.

Students' hands-on activity:

Use a measuring-tape to measure your waist circumference and hip circumference. Calculate  $WHR = \text{waist circumference} / \text{hip circumference}$ . Evaluate results using the Table 3.

**Table 3. Obesity**

WHR = waist circumference / hip circumference	Types of fat distribution / health risk	boy/man	girl/woman
	Rather peripheral / no risk	up to 0,85	up to 0,75
	Balanced / no risk	0,85 – 0,90	0,75 – 0,80
	Rather central / low risk	0,90 – 0,95	0,80 – 0,85
	Central / high risk	above 0,95	above 0,85

A questionnaire was distributed to their parents after two weeks. Parents were asked to answer four questions concerning the obesity measuring. The questions, the percentage of positive answers and the number of questionnaires received back are in Table 4:

		Percentage of answer: YES (2008):	Number of received questionnaires (2008):
1	Do you know a simple method of measuring obesity using WHR?	50	84
2	Did you receive a method of measuring obesity using WHR from your children?	43	84
3	Have you measured your WHR using this method?	22	84
4	Have you found latent obesity in your family?	12	84

**Table 4. Obesity - research results**

The results of our second research verify the effectiveness of FSE also in the lower secondary science by the use of a combination of hands-on activities and human body measuring.

### 5. Diagnostics of science gifted students by family science education

FSE might hold another essential function. It is believed to be diagnosis and development of gifted students in science. According to today's parental demands, school should provide diagnosis of a student's giftedness and carry out further development [2]. That is a principal condition for making use of student's giftedness for future positions in the labour market and also in developing the economic and social status in life.

Professional orientation and student's progress have a comparable value to desirable physical development concerning future life. Within the FSE method, the student's family is able to find out and/or verify the school's recommendation for their child's area of talent. There are different tools: finding out student's interest in science activities (keeping domestic animals, creating models, trying experiments etc.), family games and diagnostic tests that can be applied by parents. We have developed a diagnostic test for the diagnose of an analytic science observation for students aged 5-11 years. The student's ability is part of science giftedness. Below is an example of this test:

Test: „Find Einstein in yourself“

The test contains 20 items (tasks) with multiple choice. Only one answer A, B or C is correct. Particular items are chosen so as to suit quite a wide age spectrum of children, from 5 to 11 years old. We tried to balance the items against age and gender of the involved children so the problems would be taken from the world of both boys and girls. The tasks are also pictorial in order to use the test with younger children but also to support clearness and to develop associate images.

Example of test items:

Mum poured hot tea into three mugs (Figure 2). The first mug was metal, the second mug was ceramic and the third one was plastic. In which mug will the tea get cold first? (Correct answer: A).



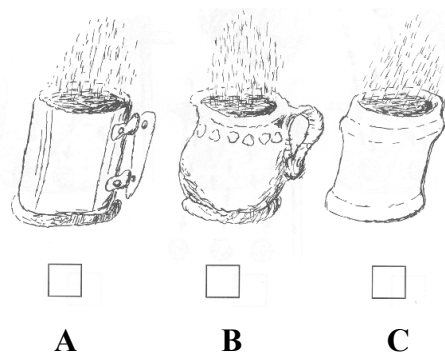


Figure 2. Heat conduction

The test was piloted in the Czech Republic in 1998 on 800 children at the ages of 5, 7, 9 and 11. It was standardized within joint Czech-Polish research [3] on a sample of 5000 respondents in 1999. The test has the following partial aims:

- to set a level of the analytical observation ability and the ability of creation of preconceptions
- to determine the relationship between the level of abilities and children's age
- to find out the relationship between the level of abilities and children's gender

## 6. Science teachers training and family science education

As a part of the whole range of other teachers' professional training techniques, the FSE method is regarded as inseparable from science teachers in-service training. It requires understanding the interaction between students and their family background. The basis of professional preparation of a science teacher for FSE is a system of knowledge and skills (pedagogical content knowledge = PCK) which form the competency for this activity. Relevant PCK resulting from FSE implementation would become a subject of research, including the action research of skilled teachers. Promising results could then be given to other teachers within their long life education.

## 7. Conclusions

FSE has a great potential to become an essential method for adult lifelong education as well as a motivational technique for gifted and non-gifted students. However, it requires additional research and eventual inclusion into

pre-service and notably in-service science teacher training. This training can be supported by efficiently passing on the best elements of skilled teachers' PCK and also by creating teaching aids and curricular materials for practical application.

## 8. Acknowledgements

The study was created and supported within the project projects "Special Needs of Pupils in Context with Framework Educational Program for Primary Education"(MSM0021622443).

## 9. References

- [1] Bransford J D, editor. *How People Learn. Brain, Mind, Experience, and School.* Washington: National Academies Press; 2000.
- [2] Kanevsky L. *Gifted Children and the Learning Process: Insightness on Both from the Research.* In: Monks F, Peters W, editors. *Talent for the Future.* Assen: Van Gorcum; 1992.
- [3] Trna J, Krajna A, Ryk L, Sujak-Lesz K, Lesz A. *Predyspozycje fizykalne dzieci przed nauczaniem fizyki w szkole.* Biuletyn Informacyjny. Centralnego Ośrodka Metodycznego Studiów Nauczycielskich w Krakowie 2000; 18/19: 48-52.
- [4] Janiuk M, editor. *Science and Technology Education for a Diverse World.* Trna J, Trnova E. *Cognitive Motivation in Science Teacher Training.* Lublin: M. Curie-Skłodowska University press; 2006. 491-498.
- [5] Trna J, Trnova E. *Everyday Living and Safe Living in Simple Science Experiments.* In: *Science and Technology Education in the Service of Humankind. 12th IOSTE Symposium.* Penang: University Science Malaysia; 2006. 556-561.
- [6] Costa M, Ed. *Selected Papers on Hands-on Science.* Trna J, Trnova E. *Safety of the Human Body in Hands-on Science Experiments.* Braga: Associacio Hands-on Science Network, Vila Verde; 2008. 572 - 579.

## Role of Household Chemicals in Recycling

R.W. Sugumar and T. Jabapriya  
Department of Chemistry, Madras Christian  
College, Chennai – 600 059, INDIA  
wilfmcc@rediffmail.com,  
nanc\_smily@yahoo.com

**Abstract.** Chemistry teachers can invigorate even the most reluctant class with a properly done and eye-catching demonstration and many common concepts can be taught using household chemicals which we use on a day to day basis. In our undergraduate ‘green chemistry’ classes we effectively use the household chemicals to highlight the importance of environmental protection through recycling of materials. For nearly a decade we have experienced the increased inquisitiveness of the students when we use these pedagogic devices for enlivening a classroom. Water is a necessary household chemical and it is becoming increasingly a rare commodity. To drive home the relevance of recycling in environmental protection, we draw a parallel with the mechanism with which Mother Nature is recycling her resources. In this context, water cycle is quoted as an example of recycling at the macro level. At micro level, the maintenance water content in our body is explained and the two strategies of our body namely ‘water loss-water gain’ and ‘water turnover’ are used to conserve body. As students realize the recycling at the macro and micro levels by nature, the hands on activities are used to impress the students how they can contribute to recycling in a small but significant way.

Apart from the recycling of natural resource like water, the recycling of anthropogenic and xenobiotic materials occupies a central position in preservation of our environment. The students are invited to collect different human made polymeric materials and they are taught the three tier system of classification of such materials. They are asked to look for the recycling symbol in them and identify the universal resin number given to these materials. The reasons for giving Arabic number 1 for PET bottles is explained and various methods of recycling options for PET are discussed. The students were thrilled to know that the fibre obtained from recycled PET

bottle is used to produce the fabric material including the T shirts and sarees.

With this understanding the depolymerisation of the PET bottle is either demonstrated to the class or the students themselves are allowed to do this experiment from the PET bottles that they have collected.

These demonstrations are combined with interesting anecdotes on material recycling and such an approach is invariably found to create a positive classroom environment and it serves as an excellent means of science communication.

The positive response of students to this approach as indicated in the survey results reiterates the success of such approaches.

**Keywords:** depolymerization, green chemistry, pet bottles, recycling, resin code.

### Introduction

The teacher centric approach of learning always revolves around the mode “I teach you learn”. With an appropriate amount of “drill and kill” methodology, a student’s field of experience can be broadened to a large extent. However, even more depth in understanding could be obtained if this linear model could be expanded to include “I learn and I can help you learn by facilitating your learning opportunities” approach. Such an approach would definitely involve the usage of “hands-on” methodology and the use of analogies.

Green chemistry is the way to provide things we benefit from today in a clean and sustainable way that does not harm the planet. Though very broad in its approach, green chemistry deals with minimizing waste, recycling, reducing resource usage, using renewable resources and improving safety.

These values can be best explained by employing experiments that illustrate chemistry of ‘real’ world. The philosophy behind recycling is best understood when articles that we use on a daily basis are subjected to recycling activity. Many plastic products, particularly those used for packing have a short period of usefulness and are soon discarded. Currently about 80% of discarded plastic ends up in landfills, with the consequent that plastics account for nearly 25% of the volume of landfill refuses [1]. In such a scenario, recycling of plastics assumes paramount importance and the students should be

motivated to develop recycling as a habit in order to save the planet [2].

### What is Recycling?

“Recycling is a series of activities that includes collecting recyclable materials that would otherwise be considered waste, sorting and processing recyclables into raw materials such as fibers, and manufacturing raw materials into new products.”

### How much water is available for the world's needs?

A hands-on math activity is tried to introduce the idea that we have a limited, shared supply of water in the world. A 4-liter bottle is filled with water. A few drops of blue food colouring are added to represent all the water on Earth. 2.5% of 4 liters is calculated (100 mL) and this quantity was placed in a clear container. This represents the amount of freshwater on Earth. 75% of this amount is removed (75 mL) to show the amount of water that is trapped in glaciers or water that is too deep in the ground to be used. This amount of water is placed in a separate container. What is left (25mL) is the total water available to us but not all of it is accessible to us. A drop of water from this water is withdrawn and placed on a watch glass. This small amount—less than 1% of the Earth's total water supply—is all the water in the world available to meet people's needs, including water needed for drinking, washing and farming.

### Water Recycling- micro and macro levels

Recycling is not a new state of art technology and Mother Nature has been using it efficiently for millions of years. Material recycling by nature at the micro and macro levels is highlighted by with the help of water management in human body and the water cycle at the geochemical level. The proper amount of water is also the key for sustaining and maintaining a healthy life. Water transports nutrients and metabolic products throughout the body to balance cell contents and requirements. Water maintains biological activities of proteins, nucleotides, and carbohydrates, and participates in hydrolyses, condensations, and chemical

reactions that are vital for life. On average, an adult consumes 2 to 3 L of water: 1-2 L as fluid, 1 L ingested with food and 0.3 L from metabolism. Water is excreted via the kidney, skin, lung, and anus. The amount of water passing through us in our lifetimes is staggering. Water is the major component of all living things. For example, the water content of the human adults is 70%, roughly the same proportion as the earth's surface.

The water content of main organs of human beings is given below:

Main organs water contents

Brain 75%

Heart 75%

Kidney 83%

Liver 86%

Lung 86%

Muscle 75%

Essentially a balance has to be maintained in animals between water gained and lost. The main source of daily gain and loss in humans can be listed as follows.

Daily gain mL Daily loss mL

Drinking 1300 Evaporation from lungs 400

Food 850 Evaporation from skin 500

Food oxidation 350 Water in urine 1500

Water in faeces 100 2500

Drinking is by far the simplest way of redressing water loss. A sense of thirst is no more a signal that water loss has exceeded gain and the balance has to be restored. The kidneys eliminate excess water.

The oxidation of food, the primary purpose of which is to provide energy for metabolic processes, also frees water within the system. For example, 1 g of fat will yield 1.1 g of water. Many desert animals have this as the main source of water. They have compensatory physiological systems, which limit the loss of water.

Evaporation of water from the lung or from the skin plays an important part in heat regulation. Most organisms' tolerance to temperature changes is quite limited. The upper limit of tolerance for most species is around 45 °C but long before the limit of tolerance is reached the body reacts to keep the temperature down. Dogs pant and exhale moist breath. Horses and humans sweat. In both cases the latent heat of water ensures that an adequate cooling effect is obtained with relatively small loss of water. In any case some loss of water by exhalation is inevitable because the presence of

water in the respiratory passages and lungs is necessary for them to function. The respired air is saturated with water. It has been calculated that humans exhale around 400 mL water per day.

Besides **gain and loss** there is a quite substantial **turnover of water** in the body. A man, for example, per day secretes 1000-1500 mL saliva, 1000-2000 mL gastric juice, 500-1000 mL bile, 600- 800 mL pancreatic juice and 200 mL intestinal juice and bulk of this is reabsorbed. The kidney too is involved in this process of turnover, around 90% of the fluid passing through it being reabsorbed and only 1% serving to facilitate excretion of unwanted metabolic products.

The water turn over mechanism represents the recycling of water by our body.

At the macro level the material water cycled and recycled via water cycle. The analogy of second hand material is highlighted here. Nature favours second hand materials and the very same water that we drink now might have been drunk by Dinosaurs long time ago.

## Green Chemistry

As a part of curriculum, Green Chemistry is taught both at UG and PG levels in the Department of Chemistry [3]. Apart from theoretical explanation on the principles of Reuse, Reduce and Recycle, students are allowed to carry out experiments based on these principles. One such experiment is the recycling of PET bottles. The cleaned post consumer recycled PET bottles are cut into the flakes and pellets and are used as raw materials to form polyester fibre in the laboratory.

## What are plastics?

Plastics are made up of building blocks called hydrocarbons, which are derived from petroleum or natural gas, also called fossil fuels. They are considered nonrenewable resources because the conditions under which they were formed no longer exist. Also, the mining, transportation and refining of petroleum creates a lot of pollution. By reusing plastics again and recycling what we can, we can help slow the virgin production of this natural resource. There are seven types of plastic, all with different scientific properties. Because of the differences in their properties,

they cannot be melted together to form new plastic. It is difficult (with current technologies) to collect and properly sort the different types of plastic from one another which makes recycling opportunities for plastics more limited than some other materials. Today, plastic numbers 1 and 2 are commonly accepted in community recycling programs. In the future, technology and innovation will hopefully lead to greater collection, recycling and remanufacture of plastics into other useable products.

## PET Waste: A new environmental problem

Polymers have become the important materials for science and technology development, and high standard of living. The modern society cannot live or progress without polymers. Synthetic polymers have become very versatile and useful materials for modern technology. Because polymers are low cost and can be easily fabricated to consumer products by fast automated machines, they have been widely used in form of packaging materials for farm, forest, dairy products and other consumer items. The usual strength and durability of polymers, however desirable they may be create threat to environmental pollution when these are discarded after use.

That the synthetic polymers, unlike natural ones, do not rust or rot or not easily degraded in the outdoor environment, they accumulate in the garbage dump site and cause litter. Thus most of the applications of synthetic polymers are based on their relative resistance to environmental degradation including biodegradation.

Indiscriminate disposal of Polyethylene tetra-phthalate (PET) bottles used in the packaging of soft drinks and drinking water is an emerging environmental problem in Chennai and its adjoining areas. Statistics reveal that in Chennai, the total amount of PET bottles generated is about 140 tones per month [4]. No proper unit for the recycling of PET bottles existed in the whole Chennai for long. The process of recycling followed an unscientific method that ends up in unauthorized bottling by unscrupulous people. Only recently, Futura polyester Ltd, Chennai is utilizing the waste PET bottles in their fibre manufacturing units as raw material.

## PET Recycling

There are a number of emerging technologies that are generically referred to as depolymerization processes. These processes -- like glycolysis and methanolysis -- break down the PET plastic into its individual chemical components, which can then be recombined back into PET plastic. While not used extensively, these technologies are employed when the economics warrant and offer yet another market opportunity for post-consumer PET plastic containers [5, 6].

The plastics are classified into a 3-TIER category.

Top Tier – The hydrocarbon backbone of polymer is entirely aromatic and includes polymers like polyphenylene sulphide.

Middle Tier – The hydrocarbon backbone is part aliphatic and part aromatic. PET is an example of middle tier plastics.

Bottom Tier – The hydrocarbon backbone is aliphatic – Examples are polyethylene (PE) and polypropylene (PP).

On moving from bottom tier to top tier, cost per Kg increases, structural integrity improves and resistance to heat, fire and chemicals improves.

Selection of PET for recycling thus represents balance between cost and performance.

In the present experiment, three grams of PET obtained from clear PET bottles and cut in 1x1 cm squares are placed in a 100mL round bottom flask along with a Teflon coated stir bar, 30 mL benzyl alcohol and 0.5 g zinc acetate. The mixture is refluxed for 24h. The product mixture is washed with distilled water and the water decanted from the mixture. After adding 50 mL of methanol to the product mixture, it is cooled in ice bath to yield white crystals of crude dibenzyl terephthalate. The crude product is dissolved in 100 mL of hot methanol and a hot filtration is performed to remove insoluble impurities. The purified product is collected and characterized.

Recycled PET is manufactured into numerous products. The five major generic end-use categories for recycled PET plastic are 1) packaging applications (such as new bottles), 2) sheet and film applications (including some thermoforming applications, such as laundry scoops), 3) strapping, 4) engineered resins applications (such as reinforced components for

automobiles), and, 5) fiber applications (such as carpets, fabrics and fibrefill) [7,8].

## Survey Results

As a part of self evaluation of the programme, a questionnaire, on a five point scale, from strongly agree to strongly disagree was circulated and the students were made to respond to the questions (Table 1).

S.No	Questions	Strongly agree %	Agree %	Neutral %	Disagree %	Strongly disagree %
1	I was challenged by the PET project portion of the course	31.58	42.11	21.05	5.26	0
2	The PET project was more time consuming than other laboratory assignments	15.79	52.63	5.26	26.32	0
3	I needed to use critical thinking skills to complete the project	0	26.32	47.37	21.05	5.26
4	Prior laboratory assignments in this course helped prepare me for the project	10.53	68.42	10.53	5.26	5.26
5	The PET project was more interesting than typical laboratory assignment	31.58	52.63	5.26	0	10.53
6	I enjoyed working independently during the project	31.58	42.11	21.05	5.26	0
7	I discussed chemistry with other students during the project	0	26.32	31.58	31.58	10.53
8	All parts of the project went as planned	10.53	20.21	5.26	64.0	0
9.	I was surprised by some results I obtained during the project	42.11	42.11	5.26	5.26	5.26
10	I would recommend continuing the programme as part of the course work	52.63	31.58	5.26	0	10.53

Table 1. Survey Results

It was clear from the survey results that the students generally agreed that the PET project was more interesting than typical chemistry laboratory assignments. Instead of wondering why a particular experiment was introduced in their curriculum, students now realize the relevance of the experiment. (Question 5). The students unanimously agreed that they needed to use critical thinking skills in the project. The structure of the project allowed the students to work independently which most of them enjoyed. (Question 6). As with any investigative chemistry problem, not all parts of the PET project went as planned (question 8). This is a valuable lesson for the students. The students were allowed to understand the reality of the problems that may arise while executing a plan.

While students did not feel that they discussed chemistry more with their classmates during PET project, (question 7), the teachers found a substantial increase in instructor-student interaction. Many students did not hesitate to ask the teacher for clarification when they encountered problems. Even when they were solving the practical problems using their skills, they did not miss a chance to check with the instructor whether they are following the right path. The informal atmosphere allowed the students to interact with the instructors without any inhibition.

The students also agreed that the project was time consuming than other laboratory assignments. (Question 2). Majority of them were also surprised by some of the results that they obtained during the project. (Question 9). There will always be differences between what we assume based on appearance and the actual chemical composition of the product obtained. An overwhelming majority of the students recommended continuing the PET project as a part of the course in the future. (Question 10).

## Conclusion

The Green Chemistry principle, 'Recycling' can be best explained by adopting the combination of hands on methods with analogies while teaching the students the method of recycling PET bottles. The students were exposed to the challenges associated with recycling plastics.

## References.

- [1] Recovering Resources-Recycling Citizenship. Jutta Gutberlet. Ashgate Publishing; 2008.
  - [2] Pongracz, E and Pohjola, V' Re-defining waste, the concept of ownership and the role of waste management', Resources Conservation and Recycling 2004; 40: 141-53.
  - [3] Green Chemistry: Theory and Practice. Anastas P. and Warner J. C., Oxford Science Publications; Oxford, 1998.
  - [4] Jayashree Vencatesan, Current Science 2007; 93(3): 290.
  - [5] Cesare Lorenzetti, Piero Manaresi, Corrado Berti, and Giancarlo Barbiroli Chemical Recovery of Useful Chemicals from Polyester (PET) Waste for Resource Conservation: A Survey of State of the Art Journal of Polymers and the Environment, 2006; 14(1): 89.
  - [6] Firas A., Dumitru P, Recycling of PET, European Polymer J.2005; 41: 1453-1477.
  - [7] Feedstock Recycling of Plastic Wastes Aguado J and Serrano D, Royal Society of Chemistry, Cambridge; 1999.
  - [8] Production-Integrated Environmental protection and Waste
  - [9] Management in the Chemical Industry Christ C, Wiley-VCH, Weinheim; 1999.
- 
-

## Communicating Science through ICT: A study of VKC's in Puducherry

D. Jayaprakash

*Research Scholar and in the Department of  
Media Sciences, Anna University Chennai,  
INDIA*

**Abstract.** The objective of this paper is to explore the functioning of the ICT intervention through Village Resource Centres (VRCs) and their sub-units Village Knowledge Centres (VKCs). This paper involved field visits, focus group discussion and non-participant observation methodology.

### Focus on Information Technology

Communication of information about science is essential for good governance. IT can help democratize governments. It can make information transparent and thus reduce bureaucratic and political control over information. APSWAN or Andhra Pradesh State Wide Area Network enables connectivity among departments as well as the various offices of each department. CARD or Computer-aided Administration of the Registration Department has become one of the most successful examples of e-governance. Many other states in India have followed suit. If not anything, such initiatives have speeded up transactions and have brought in some amount of transparency. Andhra Pradesh is setting up Internet kiosks at all public call booths in all its villages. In fact, hoarding of information is common with government departments; and data that are vital for grassroots development are normally not revealed. But ICT-centred governance would usher in free flow of government information to all those who needed it. Thus, people can benefit directly without having to grease the palm of middlemen.

The point is that IT can make a difference even in a society handicapped by underdevelopment and illiteracy. There is all the more the need to take up IT-centred development since grants are readily available for IT projects – you could easily get a grant for setting up an irrigation management information system but not for desilting the irrigation channels.

Non-government organizations involved in science-based activism such as AIDS awareness and environment awareness too employ science communicators. Of late, people are particularly interested in health and environment, and this has been reflected in increased coverage of these subjects in the media. Curriculum should also reflect this reality and offer special papers on Environment and Health. The scope for specializing in environment communication and health communication is increasing.

Information forms the basis to create awareness, though awareness to action calls for an integrated approach to development. For instance, the Kothmale project in Sri Lanka experimented with Internet browsing through radio. Here the questions of the listeners are searched in the Internet and the answers translated into the local language and contextualized by volunteers, and then broadcast. The project expanded knowledge base. According to Wijayananda Jayaweera (2001), given that information becomes knowledge only when it is discussed and contextualised in the community, the radio-browsing model has many advantages over browsing the Internet individually, particularly when language becomes a barrier to understand the content.

The Kothmale Internet browsing through radio project has opened up new job opportunities for the rural youth. It also increased the level of educational achievements among students. By encouraging community participation, the project strengthened the community bonds. Government websites constantly updated the content to augment database constantly accessed and transmitted over radio. Thus the project helped build e-governance too. Technology was demystified so that all could share its benefits. The people also took part in the management of the station and had a say in the scheduling and programming. The individualistic medium of computer / Internet (normally used only by the elite) is here made a collective medium for the masses.

### Definition of key words

Some of the key words used in the research which will be operationalized are:

- Science communication
- Science journalism

- Scientific temper
- Campus community radio
- NGO community radio
- Sciencetoon
- Exposure

### **Village resource centres**

Let us now look at the village resource centres (VRCs). The centres in the Pondicherry Union Territory of India have been developed by the M.S. Swaminathan Research Foundation in Chennai. Pondicherry, which was the administrative headquarters of the French territories in India, comprises 130 villages and the Pondicherry town. Tamil is the language spoken with English and French as languages of the administration. About 20 percent of the rural families live below the poverty line.

In 1997, MSSRF started a programme that would use access to information as the key to holistic rural development. Later in early 1998, the Information Village Research Project was established with financial support from International Development Research Centre (IDRC), Canada. MSSRF provided villages with free technology and information in exchange for the villages' promise to house the computers and staff their operation. MSSRF gave four Pondicherry villages in its network other practical, highly local information, which was distributed through the village computer network in the local language, Tamil. Mostly, information which was not on the Internet was disseminated.

The village knowledge centres were first established in Kizhur, Mangalam, Embalam and Veerampattinam villages of Pondicherry. The four villages were linked to an MSSRF hub at Villianur through an ingenious wireless system which served as a VRC. The centre at Embalam was uniquely located on the premises of a village temple, which is owned by the community through an informal trust. In each centre, a Pentium PC with multimedia and a DeskJet printer had been installed in a specially designed box to prevent rodent attacks on the instruments. The computer could be connected to the wireless network through a modem and a specially designed interface. The volunteers too

contributed news from the locality. A graduate of the Indian Institute of Technology at Kanpur oversaw the project. A local area network based on Very High Frequency (VHF) radio had been established with the Villianur office serving as a hub, handling voice communication as well as data. The project was later expanded to 12 villages of Pondicherry.

Formerly called "information shops", the village knowledge centres provide information to the rural population on relevant issues such as: health (vaccine/medicine availability in the nearest health centre); relief information (loans, availability of officials); agriculture (local market prices for rural produce); transportation information; micro-meteorological information (relating to the local area); surface and groundwater-related data; and translating English-based Internet content into Tamil and contextualizing it.

The village knowledge centres were operated by individuals on a semi-voluntary basis. Such individuals were identified on the basis of the following criteria: education (at least high school); socio-economic status (marginal farmers were given preference); gender (other things being equal, women were given preference); and age (preferably in the 20-25 age group). They were given two days of training by MSSRF. The training session consists of demonstrations of the wireless instruments, training in its use PC keyboard and mouse, and use of conditioned power supply. And one person per village was selected from among the trainees, for each of the centres.

The equipment was provided to the operators and they were trained in the basic operations of a computer, elements of word processing, spread sheets and HTML, using e-mail and Web browsing, use of the radio modem, and general matters, including basics of upkeep. The training and materials are in Tamil, the local language.

Value addition by professionals or trained individuals, to networked information helped rural families to have accessibility. A small VRC office in a centrally located village, Villianur, served as the value addition centre, where the project staff surfed the Internet for useful contacts or technologies.

Each centre varied slightly in the way it was operated and supported. In Kizhur, the volunteers were chosen by the Village Development Council, which also nominated a 23-member (14



men and 9 women) group to guide the centre's operations. At the centre in Embalam all the volunteers were women in the 21-27 age group; each of them spent half-a-day at the centre, rotating the schedule.

### **Three points to start a village knowledge centre based on MSSRF experience are:**

1. It is a people-centred programme based on community ownership. The community as a whole must endorse it.
2. It must take into account the local context and the information needs of the local people. Only then it can provide useful demand-driven services. Although we may use a variety of technologies in gathering and reaching the information, the programme is not meant to demonstrate the power of technology. Usefulness is more important than the use of latest technology.
3. The programme should be inclusive and not be associated with one group or caste; it should allow everyone to take part. The ICT-enabled knowledge centre should be located in a public space, say in a village school or panchayat building, to ensure social inclusion in access.

### **Different models tried out**

A few of the early MSSRF centres housed in individuals' homes had to be closed down, as the benefits were not reaching all members of the community, especially people belonging to the Dalit community. Social inclusion, reaching the unreached and voicing the voiceless are articles of faith in the MSSRF-IDRC ICT programme. This project was followed by several other ICT-enabled information delivery projects (often referred to as 'info-kiosk' projects) in different parts of India. Information needs vary from place to place. Villagers in a fishing village are keen to get accurate forecasts of wave heights and location of fish shoals. The women need more information on health-related issues from women doctors. That is why it is important to provide timely locale-specific information. The

information provided should be authentic and useful in the specific context. Knowledge centre staff work closely with partner organizations such as agricultural universities, Krishi Vigyan Kendras (KVKs), human and animal health institutions, research laboratories and field stations and marketing organizations.

The project continues to experiment with a range of technologies, but it is people-centred, focusing on people and their contexts. Both connectivity and content were given concurrent attention. The work in each village starts with social scientists / social workers getting to know the people and making a study of their needs and current level of familiarity with sources of information and the technological means to gather information. Rural families need both dynamic and generic information. Dynamic information includes managing and market factors as related to crops, animal husbandry, fisheries, agro-forestry and agro-processing, whereas generic information includes local news, employment news and government schemes. Information provided should be demand-driven. The project is bottom up and recognizes the local people's right to know from the very beginning. Information needs of the community and the people's familiarity with different technologies and communication channels should be assessed, particularly through participatory rural appraisal. Fostering a sense of local ownership has been an important feature of this programme. For MSSRF to move into a village and help set up a knowledge centre, the village community has to provide a room in a building which has easy access and provide volunteers as well as pay for electricity and upkeep of the centre. The village volunteers are trained in the operation of computers and maintenance of the communication equipment as well as to gather and input information. The emphasis is on overall development; i.e., the project is society-centric rather than technology-centric.

Information is a necessary but not a sufficient condition for empowerment. Information has to be linked to the means of using the information. For example, if old people are empowered with knowledge relating to cataract, they should know where the cataract eye surgery can be performed at a low or no cost (in Pondicherry, the Aravind Eye Hospital provides this facility). In fact, increased health expenditure due to serious ailments is an important reason for farmers'

indebtedness and even suicides. ICTs are tried out to bridge gender, social, economic and technological divides. The resource centre is at the core of the ICT for rural development movement.

Several other initiatives such as self-help groups, skill building, micro-credit, literacy, agriculture, health, governance and education are built around it. Poverty will persist so long as a large proportion of the rural population is engaged only in unskilled work. Here ICT is being used to bring about a paradigm shift from unskilled to skilled work and from routine on-farm to value-added non-farm activities. Having experimented with ICTs in a dozen villages in Pondicherry, MSSRF takes the concept of VRCs to other regions and other parts of the country.

This MSSRF-IDRC project was designed as a test bed for research into how ICTs could be used in rural development. MSSRF scientists have tried a variety of communication technologies for transferring information (voice, data, image, etc.) between the knowledge centres. These include Internet, VHF two-way radio, spread spectrum, World Space Radio, satellite communication using C and Ku bands and low-cost wireless technology.

Each project had its unique model. Some models were government supported, and others adopted a business model that made users pay from the beginning. Two such were established by large industrial houses, essentially to reach out to clients and supply them with products useful to them (ITC's e-chaupal and Hindustan Lever's iShakthi). n-Logue, an IT company largely promoting the technologies developed by IIT, Chennai, has a franchise model, wherein they provide an info kiosk (PC with an Internet and videoconferencing facility, scanner, photocopier) at a low cost and train the kiosk owner, and the owner provides different services and tries to earn a reasonable income.

The Veerampattinam centre, though unique in its own right, represents the model of MSSRF VRCs. The concept of a resource centre in these villages revolves around community needs and the centres have become places where anyone who needs to share information can go. The approach of MSSRF is to have people as the focus. It looks at local contexts and needs and then proceeds to satisfy those needs within their context. It is ready to use any technology that comes in handy. For example, in VRCs and

VKCs, it uses notice boards, public address systems (loudspeakers put up in different streets of a fishing village) and a local language twice-monthly community newspaper along with solar (photovoltaic) energy, the Internet, spread spectrum technology and Motorola two-way radio. Technology is often a mere enabler. What people want delivered is healthcare, education, agriculture, markets, entitlements, credit, and better livelihoods.

When the tsunami struck in December 2004 at Veerampattinam fishing village in the southeast coast of India, a mysterious spring showed up in the temple tank drawing crowds. So, when the tsunami hit the beach initially, most of the villagers were seen around the tank and could be evacuated by panchayat leaders. Mani, a fisherman, saw the waters rising when he was working on his boat motor and raised an alarm. He first alerted six women, who were on the beach, hurrying them into a boat, which was then swept into the village. He rushed to the public address system (in the VRC), which was found locked, broke it open and alerted the village. Veerampattinam, which has more than 6,200 people, lost one life that day. Thus goes a news report in *The Hindu* (Muthalaly 2004).

Such VRC initiatives of the MS Swaminathan Research Foundation (MSSRF), Chennai, are an effort to present workable models of providing information and communication technology (ICT) for development. They strive to offer services that closely suit community needs. The idea is that a well-placed computer linked with other ICT tools – like an irrigation pump or a community well – may become another tool for development. Each day, the project's staff downloaded a map from a US Navy website that showed the wave heights and wind directions at sea. This not only increased the catch of fisher folk but also contributed to their safety. The project also helped improve access to markets through the availability of prices and marketing opportunities information; improved access to health infrastructure; increased exposure of rural youth and school students to computer-based networking; increase in awareness of ecologically sound techniques in agriculture and animal husbandry, leading to enhanced income. But all these are tried out mainly through ICT intervention. MSSRF has demonstrated that a VRC is a workable model, and the National Alliance for Mission 2007 took the task of

making every village a knowledge centre by taking ICT there, before the country celebrated the 60th anniversary of Independence in 2007. This paper examines whether ICT intervention in rural development is sustainable.

ICTs can be described as a varied set of goods, applications and services used to produce, store, process, distribute and exchange information. They include both the most familiar technologies of television, radio and telephone (now called older or traditional ICTs) and the relatively newer ones – personal computers, mobile phones, satellite and wireless technologies and the Internet. Increasingly, the demarcations between these media or delivery channels are blurring as the world becomes more networked, as evidenced by interconnected telephone services, standardized computer hardware and seamless data transmission (UNDP 2001). ICT includes radio, television, telephone, computer, Internet services, web-based PCs, mobile phones, WLL network, projectors, wireless sets, I-pods, interactive boards and many more such kind of devices which are helping people to gather information and also communicate through the same.

ICT demonstrates its contribution as a tool, a resource for learning and as a catalyst in thinking. As a tool it takes on the 'donkey work' of processing and displaying information in a variety of forms. As a resource for learning, it provides insight into the nature of the subjects being studied. As a catalyst in thought, it organizes and presents information to the learner and provides the opportunity to develop higher order skills of analysis, interpretation and evaluation (Loveless 2003). ICTs can mesmerize many and distort perception and public discussion. The real crux of the matter is not technology but information. Here one would like to say that how much information is available in all the accessible and timely manner how many people at any given time surrounded by a deluge and digital hype, governmental and civil society participants at the world summit on international society run the risk of missing this crucial point (Gunawardhane 2004).

### **Self-help groups**

ICT Self-Help Groups (SHGs) are being promoted to organize and manage these village knowledge centres. The self-help group (SHG)

account software developed by the MSSRF facilitates SHGs in villages to maintain and store all its records in the computer. SHGs know people's priorities the best. According to Prime Minister Manmohan Singh (2004), there are seven priority sectors for focused attention. These are agriculture, water, education, healthcare, employment, urban renewal and infrastructure. These seven sectors (saat sutra) are the pillars of the development bridge we must cross to ensure higher economic growth and more equitable social and economic development. There are numerous ongoing rural ICT projects in different parts of the country. Synergy and convergence are attempted among all ongoing efforts.

Take the story of S. Chitra, president of the Durga women SHG in K. Ramanathapuram. She and her group are operating a highly scientific small-scale factory producing *Pseudomonas* Floureceus fungicides. They have a five-year business plan and are confident about prospects for the future. The only help they needed from MSSRF was the initial idea of what they could do as a group to improve their livelihoods. ICTs in the form of information are thus helping a group of otherwise poorly educated women take charge of their lives and that of their families.

In an area constrained by language, literacy and connectivity barriers, simply installing computer telecentres without providing assistance would be insufficient. With such assistance, the emergence of VRCs and info-kiosk movement has demonstrated that the local panchayats and self-help groups can take advantage of appropriate ICTs and that they can easily access the scientific and technical knowledge they need to solve local problems and enhance the quality of their lives, as well as to communicate their own insights and needs back to government departments and scientists. A national movement of knowledge centres needs to be established in mission mode to ensure quick implementation at the local level, create information infrastructure and locally appropriate and relevant content for rural economy through active involvement of Gram Sabhas, local SHGs and NGOs (Communication Initiative 2004).

## **Mission 2007 to Rural Knowledge Movement**

Formed in May 2004, the National Alliance for Information and Communication Technologies (ICTs) for Basic Human Needs sought to take the ICT-enabled knowledge revolution to all of India's 637,000 villages by August 15, 2007, when the country celebrated its 60th year of Independence. The Alliance saw itself as acting as a catalyst for technology innovation for rural ICT applications and connectivity. It worked to bring the private sector and the academia together with strong support from civil society organizations for experimenting every innovation among the target communities. The Alliance was using networking and partnership as strategies for taking ICTs to the poor and the disadvantaged in India's rural communities. One focus of these task force activities was how to use the ongoing efforts by the government and the private sector in creating an ICT infrastructure, human networks, and political institutions to provide multipurpose information kiosks in rural areas.

The Jamsetji Tata National Virtual Academy for Rural Prosperity had been established under the guidance of MSSRF. Mission 2007 envisaged creation of a cadre of one million grassroots level Fellows. In association with alliance partners it was identifying a million grassroots knowledge workers who will be enlisted as Fellows of the Academy. They would be the torch bearers of the knowledge revolution in Indian villages. The knowledge centres were being set up and managed by ICT self-help groups comprising both women and men.

The goal of taking the benefits of ICT to every village in the country can be accomplished only by providing a platform for partnership [particularly with grassroots civil society partnership] among the numerous agencies and individuals who are working in different parts of the country in setting up information kiosks and other methods of empowering rural people with the technologies associated with the digital age.

The first meeting of the MSSRF-Tata National Virtual Academy for Food Security and Rural Prosperity was held on February 21, 2004. In this meeting, it was decided that the NVA should help launch an Every Village a Knowledge Centre Movement in collaboration with IGNOU, the 11 State open universities and

other appropriate government and non-government organisations. The idea is to cover all villages by generating synergy between different technologies, particularly between the Internet and the community radio and the symbiosis among all institutions engaged in the field of technological and skill empowerment. Although the target was not achieved within the specified period, it was worth the effort.

The deadline passed by without much of the task of Mission 2007 being accomplished. But the cause was noble. Mission 2007 concretized the concept of ICT enabling of all the villages of India. After August 15, 2007, it was converted into the Grameen Gyan Abhiyan (Rural Knowledge Movement). The so-called movement has over 400 partners with an aim to creating a rural knowledge revolution. It has built multi stakeholder partnership with different ICT4D models. They include the community based models, entrepreneurial models, government models, business models or the corporate models, cooperative models, and combinations of all these models in pairs or more. The movement aims to address the knowledge gap that exists in rural areas, and the divide between the Shining India and the non-Shining majority. It strives to develop a user controlled, owned and managed network which will help reach the rural population in terms of information, knowledge and skill empowerment.

### **Lessons learnt**

The MSSRF initiative of setting up VRCs and VKCs gives contextualized information to villages regularly. The VRC earlier functioning from Villianur has been shifted to Pillyar Kuppam. Thirteen VKCs functioning under that VRC are managed by local volunteers. The projects are supported by grants from the International Development Research Centre, Canada, and other agencies. Notice-boards, loudspeakers, and a local newspaper are used to disseminate information. Notice-boards are updated daily. Loudspeakers are used to announce weather forecast twice a day and other information such as the schedule of panchayat meetings. Since 2002, *Namavoor Sethi* (Our Village News) comes out as a fortnightly newspaper giving government news, political news, employment news, healthcare news, and agricultural information. Now the newsletter is

being distributed at the doorsteps, but this procedure is going to be changed and the newsletter will be henceforth kept in the VKCs itself to eliminate distribution efforts and to make all the villagers visit VKCs.

VKCs have a Microsoft Unlimited Potential Programme through which free self-learning CDs are given to high and higher secondary students to teach themselves courses such as Computer fundamental, Microsoft Word, Microsoft Excel, Microsoft Powerpoint, Microsoft Access, Digital Media, Internet Browsing and Web Designing. The students who finish a two-month course are awarded certificates from the Microsoft. But most students use the VKCs only for playing computer games, which nevertheless makes them computer savvy. Occasionally, VKCs conduct awareness programme against AIDS and liquor consumption. Vermiculture and mushroom farming have been tried out with the information backing from VKCs.

One question repeatedly asked is that why India, weighed down by high rates of illiteracy and underdevelopment, should spend heavily to provide villages with ICT. Should not the priorities be on schooling, health and agriculture? But then, we should not be lacking behind in information technology revolution that is gripping the entire world. Also, the mere fact funds are readily available for IT rather than tackling malnutrition means that IT for grassroots development needs to be taken up. According to M.S.Swaminathan (2007), "from my long experience in agriculture, I find that whenever poor people derive some benefit from a technology, the rich also benefit. The opposite does not happen."

Information technology, particularly the Internet, has opened up new frontiers. The Internet has no borders, no censors and no Big Brother. It could be a place to learn about issues, connect with those affected by issues, start conversations about remedies, raise funds for solutions, coordinate solution teams, post the whole process and invite real-time feedback from participants around the world. Organizations working for social change are already employing information technology and the Internet to achieve their goals (Tresser 2003).

Local bureaucrats are often reluctant to give up their monopoly on information, which can be a source of power used to extract bribes. This

may be one of the reasons why ICT intervention fails once the demonstration phase is over. Not always the success of a project should be seen in terms of its sustainability in terms of continuance of the project. A good number of VRCs and village knowledge centres of MSSRF might have folded up. After the demonstration phase, such projects often cease as grants dry up or the project manager on the spot quits taking up a high paying job. But one's loss is another's gain and thus the skills imparted to the project staff do not go waste.

Also, the fact is that the villagers have undergone an attitudinal change and they have got over the fatalistic mindset. More so, they have been focusing more on livelihood issues which no doubt ranges high in the priority list of villagers. If villages abandon virtual communities and involve actively in local (physical) communities, there is nothing wrong in it. After all, the focus of VKCs was on how the communities could improve their livelihoods using information to innovate, and take charge of their own destinies.

Harris and Rajora (2006) studied whether the ICT projects were reaching goals of utilization by communities to improve lives and livelihoods through better access to education, agricultural information, weather, health information, and markets. They found that there is a need to train staff for skills in organizing the community to continually expand use of the technology and skills for dependable maintenance of technology. The users should have a say in determining the sort of technology and content.

A few of the early MSSRF centres housed in individuals' homes had to be closed down, as the benefits were not reaching all members particularly the marginalized. Likewise, lessons can be learnt from experiences. The centres should be located in a public place and not be associated with any one caste or group. Bridging divides such as digital divides, caste divide and gender divide is a prime aim of ICT intervention.

A sustainable business model should be evolved. Public-private partnership has proved to be the most sustainable model, based on the MSSRF experiments. This will also take care of the public relations aspect of the project at least in the interest of the partners. A wide range of services should be offered with the most basic technology possible. The services offered should be closely related to the needs of the community.

The info-kiosk should serve as a communication hub, providing multiple telephone and communication services to the village, a virtual academy and training centre and banking, to have greater economic viability.

Democracy requires that people have the ability to move from participation to power. A strategy of working through and with grassroots organizations needs to be adapted. Partnership in terms of local civil society activism rather than posh corporates or NGOs will promote sustainable rural development. The activism of these kinds of grassroots organizations is the need of the hour. It can serve as an effective democratic tool, if grassroots organizations are strengthened.

Some NGOs use the Internet to learn about the experiences of their counterparts elsewhere and replicate them in their area without adapting them to the local context. This short-cut solution is counterproductive. The same problem is there when MSSRF's village resource centres are replicated without much understanding of the social processes (which include an agrarian orientation) that went along with it.

The successful Satellite Instructional Television Experiment (SITE) of 1970s had to cease as the American satellite was made available for the project for just one year. The father of the Indian space science, Vikram Sarabai, had said India would use the satellite communication and leapfrog into developing; but this did not happen despite initiatives in satellite-based communication. This does not mean satellite TV was incapable of doing this. The fact is (i) communication for development was not promoted extensively and (ii) other infrastructure necessary for development was not made available. IT initiative at the grassroots can take lessons from SITE. It is better not to depend on temporary high technological intervention. Some low profile sustainable technological models like the use of loudspeakers along with a computer centre will work wonders. Unless ISRO or some corporate sponsors are ready at hand or a revenue model is in place, continuance of the project is not possible.

Routine power failures and overloaded telephone lines make connecting to the Internet a frustrating proposition. Of course, solar power and wireless telephone have also been tried out.

An integrated use of the Internet and community radio will be an effective means of

reaching the unreached and giving voice to the voiceless, now that NGOs can set up community radio stations in India.

The local communities should be able to run the centres when the implementing agency withdraws its backing. The centres should be owned and managed by ICT self-help groups, grassroots institutions such as local panchayats, farmers' associations, or fisher folk's cooperatives. Members of all strata such as caste and gender should form part of such a centre. Some technical skills required for maintaining a connectivity infrastructure should also be in place.

## References

- [1] Communication Initiative. "National Alliance for Information and Communication Technologies (ICTs) for Basic Human Needs - India." [www.comminit.com/pds72004/sld-10439.html](http://www.comminit.com/pds72004/sld-10439.html) 2004.
- [2] Chowdary, T.H. 'Andhra Pradesh - a success story.' A paper presented at a national seminar on 'Electronic Governance & Democracy in the New Millennium - Challenges & Opportunities', AMIC-India, Chennai, Dec. 11 and 12, 2000.
- [3] Dagron, Alfonso Gumucio. "Village Knowledge Centre." *Making Waves - Stories of Participatory Communication for Change*. New York: Rockefeller Foundation, 2001.
- [4] Gunawardene, Nalaka. "When the World Collides?" *Media Asia* Volume 31, Number 2. 2004.
- [5] Harris, Roger, and Rajesh Rajora. *Empowering the Poor: Information and Communications Technology for Governance and Poverty Reduction*.
- [6] Asia-Pacific Development Information Programme (APDIP), 2006.
- [7] Jayaweera, Wijayananda. "A Pilot in Integrating Radio and Internet - Kothmale Community Radio in Sri Lanka." [http://www.unesco.org/webworld/public\\_domain/kothmale\\_docs/seminar\\_report.pdf](http://www.unesco.org/webworld/public_domain/kothmale_docs/seminar_report.pdf) 2001.
- [8] Loveless, Avril. *The Role of ICT*. London: Continuum, 2003.
- [9] Muthalaly, Shonali. "A Phone Call Saved an Entire Village." *The Hindu*. Chennai, December 31, 2004.

- [10] Singh, Manmohan. Independence Day Address, New Delhi. August 15, 2004.
- [11] Swaminathan, M.S. Quoted in "Making Waves" Communication Initiative. [http://www.idrc.ca/en/ev-102848-201-1-DO\\_TOPIC.html](http://www.idrc.ca/en/ev-102848-201-1-DO_TOPIC.html) Accessed in March 2007.
- [12] Toolkit for Setting up Rural Knowledge Centres. Chennai: M.S. Swaminathan Research Foundation, 2005.
- [13] Tresser, Tom. "The Internet is not a mall." <http://www.tresser.com/change.htm> Accessed in 2003.
- [14] United Nations Development Programme. Information Communications Technology for Development: Synthesis of Lessons Learnt. New York: UNDP Headquarters, 2001.
- 
- 

## Utilisation of Fly Ash in the Construction of Roads and Embankments

S.K. Chaudhary

Assistant Engineer, Road Construction Dept,  
Patna, INDIA

**Abstract.** Fly ash is a waste material produced by thermal power stations during the process of generation of electricity by using Coal. Indian Coals have very high ash content, as high as 40-50 percent and about 70% of coal produced is utilized for power generation. With the increase in installed thermal capacity and poor quality of coal, huge quantities of fly ash is getting accumulated near thermal power plant posing environmental problems. Hence there is an imperative need for bulk utilization of fly ash. Roads and embankments is one such application in which fly ash can be gainfully used in bulk quantities replacing the scarce top soil and valuable mineral resources. This paper describes the various methods of road and embankment construction using fly ash, their technical and economic aspects and gives salient details of some national and international project also.

### Introduction

Roads are the life line of any nation. It is needless to say that Network of road play major role in progress and prosperity of the people.

There are 75 thermal power stations in India which produce about more than 120 million tons of fly ash every year. It poses problems of contamination to land, water as well as environment as a whole. Hence, all the civil Engineering fields have to take urgent steps for disposal / utilization of fly ash in the most economical way. The present level of utilization is very low. Potentially fly ash can find many application such as building materials like bricks and cement, construction of dams and hydraulic structures, as a filler material in mines, soil conditioner and fertilizer in agriculture and extraction of products like alumina, magnetite etc. On many of the possible applications of fly ash, extensive R&D works has been done in India and abroad. Technology is therefore known for bulk utilization of fly ash in different fields, a major area of bulk utilizations is civil engg.

work, one of which is road and embankments. Research and experiences have shown that it is possible to achieve economy by use of appropriate mix of soil – fly ash and soil – lime – fly ash without compromising the quality of end product. Similarly fly ash can be used for constructing rigid pavements and embankment fill material.

### FLY ASH FOR EMBANKMENT AND ROAD CONSTRUCTION

Fly ash is a refractory material and abrasive in nature and its particle size is very fine. Over 85 percent of coal used for power generation in India is bituminous rank and the remaining lignite. Hence, most of the generated fly ash is F type and contain < 10% Cao. The average specific gravity of fly ash particles varies from 1.9 to 2.4.

Difference between Indian and US fly ash is given Table 1.

S.No.	Property compared	Indian Fly ash	US Fly ash
1	Loss on Ignition	<2%	5-8%
2	SO <sub>3</sub> Content	0.1 – 0.2%	3 – 4%
3	CaO Content	1 – 3%	5 – 8%
4	Increase in concentration of trace elements after combustion	3 – 4% times in comparison to source coal	10 times or more in comparison to source coal
5	Rate of leaching	Lower	Higher

**Table 1. Difference between Indian and Us Fly ash**

Fly ash proves as the best soil substitute with superior shear strength and engineering properties. These properties can be augmented through stabilization with lime Or OPC. Thus fly ash can find place for embankments and sub grade in roads. For such a potential associated with Fly ash, the attention paid in India is decimal in the background of more than 120 million tons of generation annually, and massive infrastructure needs throughout the country.

As per the Australian guide, strength and compressive properties of fly ash resemble a medium to dense sand, but with a compacted mass of only 60 percent to that of dense sand. Hence the guide recommends the use of fly ash for backfilling retaining walls or for constructing

embankments, enlisting the following characteristics:

- High internal angle of friction
- Low unit mass
- Low compressibility
- reduced settlements when used as fill material
- ease of compaction
- its self hardening properties, resulting in a possible reduction in fill pressures on structures.

Utilization of fly ash in bulk quantities for road work depends on the interaction between fly ash and sub grade soil. If the type of soil available in the area is found to be amenable to pozzolanic action with fly ash, strength parameters of soil would improve when fly ash is added. This characteristic of fly ash is important in formulation of pavement specification and permits utilization of fly ash in bulk quantities for road construction. Generally clayey soil reacts with pozzolanic compounds present in fly ash. No such reaction has been observed in case of sandy soils or gravels. Silty soils also react with fly ash to a limited extent; this reaction can be improved by using an additive such as lime. Fly ash has been used for constructing different layers of road pavements, details of which are given below:

#### 1. Sub base / Base Construction

Conventionally water bound macadam (WBM) has been used as the base course material in majority of the Indian roads. Presently wet mix macadam (WMM) has been used as the base course material in majority of the Indian roads. The filler used for WBM/WMM and being a material of low plasticity, it has very little binding property. Hence, WBM/WMM gets softened on being wetted. As a result pot holes are formed under traffic which gets enlarged subsequently. Lime-fly ash bound macadam using lime stabilized filler (mixture of lime, fly ash and sand or gravel in suitable proportion) will inhibit softening in presence of water effectively lead to longer life and better serviceability of the roads. The proportion 1:2:9 of lime, fly ash and gravel /sand has been found to be satisfactory.



## 2. Semi rigid / Rigid pavement

Fly ash can be utilized for constructing upper layers of pavement using specifications of lime fly ash concrete, dry lean cement fly ash concrete, roller compacted concrete, high performance concrete etc. These types of materials are referred to as semi rigid pavements due to their higher flexural strength. They can be adopted in a variety of ways like base courses or wearing courses of heavy traffic corridors or low traffic volume roads respectively.

Lime fly ash concrete is particularly suitable for heavy rainfall areas, black cotton soil areas and location where good quality aggregates are not easily available. The stiffer lime fly ash concrete layers distribute the load over large area of sub grade through slab action thus transmitting lesser amount of the stress to the sub grade. Lime fly ash concrete is designed with zero slumps as compaction in the field is generally done by rollers.

Dry lean cement fly ash concrete (DLFC) uses fly ash for partial replacement of sand. Research shows 100 to 175 percent increase in compressive strength by mixing 50% fly ash in place of sand. This has benefits like reduced bleeding, lesser segregation, improved cohesiveness and reduced pavement thickness due to higher strength. Similarly roller compacted concrete (RCC) is a zero slump Portland cement concrete which is placed using a paver and compacted using a road roller. In RCC paving, 30 – 50 percent of cement can be replaced using fly-ash. It can be used primarily for heavy loaded area, but best suited for low and medium traffic volume roads. RCC can be used for all categories of road as lower layer.

High performance concrete (HPC) is a recent development in concrete technology. Very early strength concrete can be used for repairing cement concrete pavement and very high strength concrete can be used for pavement construction. Fly ash is an essential ingredient of HPC. Use of HPC in road pavement can result in lesser pavement thickness, extended service life, reduction in self weight and possibility of early opening to traffic.

## 3. Embankment Construction

Intermediate soil layers are often provided in the fly ash embankment for ease of construction, to facilitate compaction of ash and to provide

adequate confinement. The compacted thickness of intermediate soil layers may vary from 0.2m to 0.4m. Such intermediate soil layers minimize liquefaction potential. To avoid the possibility of any liquefaction to occur, fly ash should be properly compacted to at least 95 percent of modified proctor density and in case water table is high, it should be lowered by providing suitable drains or capillary cut off. The top 0.5m of embankment should be constructed preferably using selected earth to form the sub grade for the road pavement. Even though fly ash can be compacted using either vibratory or static roller, vibratory rollers are recommended for achieving better compaction. Compaction is usually carried out at optimum moisture content or slightly higher. Side slopes of 1:2 (V: H) is generally recommended for embankment construction using fly ash. Geo-synthetic materials like geo-grid or geo-textiles can be used as reinforcement for construction of fly ash embankments. This will improve the shear strength, minimize deformation and avoid necessity of retaining walls. Steeper slopes are possible with the provision of geo-grid / geo-textile reinforcements. The design of fly ash embankments is basically similar to design of soil embankment. The most common type of failure of embankment is toe failure, slope failure and base failure. Regardless of the type of failure, the basic principle of stability analysis is to compare those factors contributing instability to those resisting failure. The design methods use limits equilibrium method for stability analysis of embankment. Computer software is also available for quickly analyzing stability of different types of section.

### Technical aspects

For a fill material to be used in roads and embankment, the properties of concern are specific gravity, compaction characteristics, workability, angle of internal friction, cohesion etc. Through the variation in the properties of fly ash from one thermal power station to another does exist, but it is not so significant as compared to such variation in soils. Fly ash from power plants in India has properties as discussed in following paragraphs:

- **Specific Gravity:** Specific gravity of coal ash particles ranges from 1.8 – 2.0 as

compared to that of soil which is in range of 2.6 – 2.7 g/cc. Due to lightweight, it imparts less load on sub-soil, hence can be used on weak sub-soils.

- **Compaction Characteristics:** It is the most important parameter for selection of a material for roads and embankments. Here too, coal ash has a favourable point. It may be noticed that though the maximum dry density of fly ash at OMC is less than that of soil, but it is not due to loose compaction or presence of the voids, rather it is due to lower specific gravity of ash particles. Further fly ash is easy to compact and can be compacted by using either static or vibratory rollers.

- **Permeability:** Fly ash has permeability in the range of  $10^{-4}$  cm/sec. Its high permeability ensures free and efficient drainage.

- **Rate of Consolidation:** Fly ash gets consolidated at a faster rate and primary consolidation gets over very quickly. So it has low compressibility and shows negligible subsequent settlements. Thus it can be used in bridge abutments also.

- **Bearing Capacity:** Fly ash has higher value of CBR as compared to soil. So it can provide a more efficient design for a particular load bearing capacity.

- **Shear Strength Parameters:** Fly ash has angle of internal friction in the range of  $35^{\circ}$  to  $42^{\circ}$ , which is quite high as compared to that of soils ( $30^{\circ}$  to  $35^{\circ}$ ). Value of the angle of internal friction increases even more upon compaction. Fly ash when moist possesses apparent cohesion too. So it can provide greater stability of slopes as compared to soil, and slope steeper than that for soil can be provided in the embankments.

### Other aspects

Other aspects which add to the advantages in the use of fly ash in geo-technical application are also equally important. A few of these are highlighted here:

- **Easy availability:** Almost all the thermal power stations have the problem of disposal of high volumes of fly ash generated by them. In such circumstances thermal power stations would like to supply as much fly ash to its users as they require. Thus fly ash is abundant and almost freely available material.

- **Environment Protection:** Fly ash, if not disposed of safely or utilized gainfully, may be a

hazardous waste / environmental pollutant. By utilizing fly ash in roads and embankments, not only the problem of disposal of fly ash can be reduced, but also demand of land for dumping of fly ash would be reduced. The top soils, which were traditionally used in construction of roads and embankments, would also be saved, which is a scarce resource, creating low lying areas and depriving the country of agricultural product from the fertile land.

- **Economy:** Most of the time good soil is to be transported from long distances, which is highly uneconomical. On the other hand fly ash is available at almost zero cost except the transportation cost. Thus there can be enormous amount of saving by using fly ash in roads/embankments if fly ash is used in place of soil. Apart from direct savings there are indirect savings in the forms of cost of safe disposal of fly ash; cost of land required for fly ash disposal and cost of fertile soil.

- **Performance:** The post construction observations have established that fly ash is no longer a waste material and has been proved as a better alternative to the soil for road and embankment construction.

### Experience of using fly ash in road sector

After considering all the concerned factors (technical, environmental, economical etc.) one would appreciate that fly ash is a better alternative to the soil for road / embankment construction and its use makes sense from all angles.

### National Scenario

Brief details of some of the projects executed in the recent past are given below:

- i. High Volume Fly-ash (HVFA) Road at Ropar: HVFA technology was adopted for the first time for constructing a small stretch of road near Ropar, Punjab. The length of two-lane road is 0.75km and thickness is 300mm. The pavement concrete was laid directly on the existing road. Nearly 50% Portland cement of 53 grade was replaced with fly ash to produce HVFA concrete.

- ii. Construction of Reinforced Approach Embankment for Vishveshvaraya Setu: Delhi Public work Department (PWD) in

association with CRR I and Fly ash Mission, constructed the reinforced fly ash approach embankment on one side of the slip roads adjoining NH-2 in the Vishveshvaraya Setu (Okhla flyover) project. The length of the approach embankment is 59m while the height varied from 7.3 to 5.3m. Geogrids have been used for reinforcement of fly ash and a total quantity of 2700 cum of ash was used for filling.

iii. Construction of Demonstration Road embankment Stretch at Raichur: At Raichur in Karnataka State, demonstration stretch of 1 km length of MDR was constructed during Dec 96-Apr 97, using fly ash from Raichur Thermal Power Station. Fly ash was used for sub-base and base course construction and also for construction of one section of rigid pavement (dry lean cement fly ash concrete overlaid with roller compacted concrete).

iv. Construction of Eastern Approach Embankment for Second Nizamuddin Bridge: A new four lane bridge has been constructed across river Yamuna along side of the existing Nizamuddin Bridge on NH-24. Fly ash from near by Indraprastha Power Station was used for construction of this embankment.

The Project is unique of its kind, as fly ash has been used for construction of high embankment in the flood zone. A total quantity of about 150,000 ton of fly ash was used for construction.

### International Scenario

Many projects involving use of fly ash in road and embankment construction have been completed successfully abroad. Some successfully completed projects, which have shown good performance, are given below:

i. High volume fly ash road: In Wisconsin state of USA, HVFA concrete roads with 50% cement replacement with fly ash is performing satisfactory since 1983.

ii. Delaware Ash ramp Embankment Project: In this project nearly 10,000 ton of stockpiled ash was used to construct the main access ramps for the interchange in 1987.

iii. Pennsylvania Ash Embankment Project: Approximately 3,50,000 ton of fly ash was used for highway embankment construction near Pittsburgh in 1988. The embankment is approximately 500m long, 80m wide and 16m high.

iv. Georgia Highway Ash Sub-base Demonstration: In cooperation with the Georgia Department of Transportation, Georgia Power Company and Georgia Environment Agency, a three part test section of a two lane high way was designed to include ash as a sub-base and base course material. The project was completed in 1985.

v. Machigan Road shoulder replacement with Coal Ash: A test section of four lane state high way was designed to include ash as a base course material under the road shoulder. Ash has been stabilized using cement. The project was completed in 1982.

vi. Kansas Highway Recycled Pavement Demonstration Project: This Project involved pavement recycling using class C fly ash. The project was completed in 1982.

vii. Processing concrete Pavement Demonstration: The highway demonstration project of most interest to concrete design community was executed in 1988 in North Dakota, in which 70 percent of the cement in concrete pavement was replaced using fly ash.

### Economic aspects

Apart from direct saving involved with fly ash in construction, there are indirect savings in other cost also. These other costs are in the form of cost of safe disposal of fly ash, Cost of land required for fly ash disposal and cost of loss in food grain production, while that soil would otherwise had supported.

The economy in the cost of road construction using fly ash would depend on the leads and cost of various materials. From cost analysis it was observed that though the initial cost of construction with lime fly ash techniques having composite rigid pavement and surfacing may be at par or more (about 19.3%) than the conventional considering the total cost incurred (including their in-service maintenance ) for their long term performance up to 25 years, the rigid surfacing specifications with semi rigid layers are 44.0-50.7% cheaper whereas the composite semi-rigid layers with flexible top are only 6.8% cheaper than the conventional specification.

### Conclusion

1. Large scale utilization of fly ash by adopting lime fly ash techniques for road constructions will greatly assist in the disposal of

fly ash which is a source of atmospheric pollution and the disposal of which is considered to be a national problem.

2. Lime fly ash techniques provide semi-rigid characteristics to the pavement layer and improve load bearing capacity of pavement.

3. Fly ash base construction technique for road embankment is economical.

4. Due to minimal maintenance cost as well as better performance, the existing conventional technology of road and embankment construction should be immediately replaced with fly ash based technology.

5. A thorough geotechnical investigation of the site and fly ash would be necessary to execute successful road and embankment projects incorporating fly ash as construction material.

6. The use of fly ash in roads and embankments is the only such possible use where a major part of the country's production can be consumed.

## References

- [1] Murty, AVSR, Guru Vittal, U.K., Havanagi, V.G., 'Construction of road embankments using fly ash', Proceedings of the National Seminar on fly ash Disposal and Deposition – Beyond 2000AD, Organized by IIT, Kanpur, 1999, pp 198-203
- [2] Dean M. Golden, 'Expanding Coal ash utilization in concrete construction', International Symposium on Concrete technology for Sustainable Development in the 21<sup>st</sup> Century, Hyderabad, 1999, pp 97-125.
- [3] CRRI Project Report on Second Nizamiddin Bridge Approach Embankment, 1999;
- [4] Electric Power research Institute, California, 'Fly ash Design Manual for Road and site Applications, Prepared by GAI Consultant, 1992.
- [5] IRC 36-1970, Recommended Practice for the Construction of Earth Embankments for Road Works.
- [6] IRC 75- 1979, Guidelines for the Design of High Embankments.
- [7] CRRI, Construction of Reinforced Soil Wall at Okhla Flyover, New Delhi, Project report, 1996.
- [8] CRRI, Construction of Reinforced Soil Wall at Hanuman Setu, Delhi Project Report, 1996.
- [9] CRRI, Utilisation of Fly Ash in the Construction of Eastern Approach Embankment for Second Nizamuddin Bridge, New Delhi, Project Report, 1999.
- [10] Deep Chandra, Guru Vittal, U.K., Murty, AVSR, 'Road construction using Fly Ash Aggregates', International Symposium on Beneficiation, Agglomeration & Environment, Bhubaneswar, 1999, pp 38-41.
- [11] Singh R.B, Khanna Pallavi, and Agrawal R.K, 'Utilisation of Fly ash in Embankments with Geogrid and Anchor Reinforcement', National Seminar on Fly ash characterization and its Geotechnical Applications, Indian Institute of Science, Bangalore, 1999, pp 179-186.
- [12] Singh R.B, Khanna Pallavi, 'Studies on Combined System Reinforcement for Raising of Ash Dykes and Embankments, Proc. Indian Geotechnical Conference, Calcutta. 1999, pp299-302
- 
-

## Alteration in Antibacterial Potential of *Nigella sativa* L. Seed During Different Phases of Germination

I. Zareeen Ahmad, A. Kamal  
and J.M. Arif

Department of Biotechnology, Integral  
University, Dasauli, Kursi Road,  
Lucknow-226026  
Uttar Pradesh, INDIA  
iffat77@rediffmail.com

**Abstract.** *Nigella sativa* L. belongs to family Ranunculaceae. It is an annual flowering plant used widely in India and other Asian countries as a condiment and flavouring agent in food. Since the ancient times, the plant is being used for several ailments, as in infectious diseases and metabolic disorders. It has also been used traditionally as spice, carminative, condiment, aromatic, stimulant, diuretic, stomachic, liver tonic and digestive. It has been found useful in loss of appetite, vomiting, and puerperal diseases. It is also used commercially as emmenagogue and galactagogue and stimulant of uterine contractions. Some scientists have also explored its antibacterial and antifungal activities. The rate at which the bacterial strains are becoming resistant to the available antibiotics has necessitated the demands a renewed effort to investigate for new antimicrobial agents which could prove to be effective against pathogenic bacteria resistant to current antimicrobials. *Nigella sativa* seed, in various germinating stages, was studied for antibacterial activity against various pathogenic bacteria resistant to a number of available antibiotics.

The pathogenic bacteria used for the present study included Gram-negative bacilli, namely, *Pseudomonas aeruginosa*, *Enterobacter aerogenes*, *Klebsiella pneumoniae*, and *Salmonella typhimurium* and Gram positive bacterium, namely, *Staphylococcus epidermidis*. The aqueous extracts of *Nigella sativa* in various germinating stages were prepared by distillation and concentrated in vacuum. The powder was dissolved in dimethyl sulfoxide prior to the test. DMSO was used as a negative control showing no effect on the growth of bacteria. The extracts were tested for antibacterial activity using Broth dilution method to determine minimum inhibitory concentration and agar cup diffusion

method to determine zone of inhibition. The antibacterial potential of the extracts was also compared with the commercially available broad-spectrum antibiotics, namely, streptomycin, penicillin, ampicillin, tetracycline, erythromycin, and doxycycline which were also used as a positive control. All the microorganisms tested were resistant to ampicillin and penicillin. The highest antibacterial activity was seen on 9d, 10d and 11d of germination while the seed at 0d showed no activity. The zone of inhibition ranges from 15 to 20mm. It can be concluded that there was moderate antibacterial activity. The results showed day-dependent activity and not the dose-dependent activity.

Phytochemical studies on *Nigella sativa* seeds revealed the presence of volatile oil (1.5%), fixed oil (37.5%), nigellin, melanthin and thymoquinone. Secondary metabolism starts usually when the primary metabolism runs at top speed and enough assimilates required for further use have been accumulated. The variation in the antibacterial activity shown by the seeds in different stages of growth and development might due to the changes in the content of these metabolites. In dormant seeds, no DNA replication occurs and protein biosynthesis works at a hardly detectable level. During germination, there is always an increase in volume due to water uptake by the cells. This results into the initiation of numerous metabolic activities. During growth, the metabolic processes reach their optimum level. As a consequence there is an increase in biomass rapidly. These variations in the metabolic activity might lead to the alteration seen in the antibacterial activity.

**Keywords.** *Nigella sativa*, germination phases, extract, antibacterial activity, resistance.

## Promotion of Scientific and Technological Temper

G. Shankar  
Govt Teacher's Education College,  
Khagaria, INDIA  
g\_shankar\_2007@yahoo.co.in

**Abstract.** Even sixty-two years after independence, despite several government-run programmes and Ngos spousing the cause of rational experimentation and debunking superstitions, we have not been able to make a significant change in the mindset of the Indian populace. Our efforts at inculcating scientific temper have not given the desired results. Superstitions are not confined to villages alone. There has been a disturbing rising trend in superstitious beliefs of late. For instance, more marriages are being decided on the basis of matching of horoscopes than a generation ago. Besides, new superstitions such as Vastushastra and Feng Shui have caught the fancy of people of almost all strata of society. It is so hard then to inculcate a scientific and technological temper in individuals. I am of the view that everyone is born with a science temper. The child wants to touch, feel, experiment, explore everything on its own—the basic ingredients of scientific temper. Our existing education system stops children from questioning and exploring. As a result, they lose the tendency to ask questions and explore natural phenomena, rather accepting notions forced upon them without putting them through the scientific rigour.

This paper presents in brief how head and hand go hand in hand for the promotion of scientific and technological temper. The findings are based on 'The Hands-on Science Project for 20 schools'. The findings of a case study of two villages and one municipal area reflect the rising trend of superstitions which cause financial burden on the people and developmental hindrances.

This paper tries to answer the questions:

How hands-on science can contribute to the promotion of scientific temper; how scientific temper should be incorporated in to the school curriculum and how through it we can have an access to the common people.

The information from this paper will be useful for planning science education in order to

meet the challenge of promoting scientific and technological temper of the Indian populace.

**Keywords:** rational experimentation, superstitions, horoscopes, vastushastra, feng shui, scientific temper.

### Introduction:

The status of science education in the country is very shocking. Though Indian scientists have made their mark, the country still lags behind and even today science remains mostly confined to the scientific world. Since science education in our country is faulty, it cannot be a matter of masses. It is really a dangerous proposition. The lack of proper science education and scientific temper create a vicious superstitious belief system. A number of stories from time to time crop up from the different parts of the country narrating their woes generated by superstitions.

Head and hand must go hand in hand for the real achievements of science. New awakening requires undoing the errors of science and restabilising the public understanding of science and technology by starting a science literacy campaign through the formal system of education which we already have.

There is a need to expand the horizons of science and technology to the poorer sections of society. The word 'scientific' was first used in 1840 by W. Whewell. Science is reasoned knowledge about facts, things, persons, natural phenomena and social behaviour. 'Temper' is a particular state or habit of mind especially with respect to disposition. Therefore, scientific temper represents a spirit of inquiry based on logical reasoning. The ability to think objectively, logically and analytically leads to the development of scientific temper. This paper attempts to devise the way to nurture scientific temper that one can be liberated from dogmatism, irrational beliefs and superstitions. One of the innumerable examples of the season of miracles goes back to 2006 when it all started with the waters of the sea in Mumbai turning sweet, or putting it more scientifically, less salty. The next we heard it was idols drinking milk, and then a tree oozing water and the form of a renowned saint appearing inside a cave. Not only this, we heard of sacred water coming out from idols and Christ entering a human body as part of a special occult session in a prestigious Lucknow

school- it goes on and on, until one starts wondering whether India has suddenly turned into a hotspot or the most favoured destination for miracles of all kinds and hues.

Scientific explanations are available for all such miraculous occurrences. But the human mind is often conditioned to accept facts as they are told without inquiry. Moreover, with people facing situations of grief and sorrow, of pain and suffering, and of illness many of which are at present untreatable, long-drawn-out and intractable, they often turn to what would be regarded as supernatural or irrational, for some amelioration and relief. It is recognized as basic human psychology. There is also the ever-present danger of power brokers and vested interests arranging such miraculous occurrences for their own narrow, monetary and even vicious ends. Blind faith in miracles and other supernatural phenomena promotes dependency on godmen, magicians, tantriks and other power brokers. Blind faith could destroy people's health, as happened in Mumbai when gullible people began drinking the dirty sea water; it could destroy people's wealth, as when precious milk went down the drain in the belief that idols were drinking it; it could even destroy lives, when the gullible sacrifice of children's lives on the advice of godmen and tantriks.

It is sad that science and scientists have not done enough to dispel irrational and unscientific beliefs. A major effort on the part of the scientific community is called for in this regard. My approach consists of an organized attempt to address the problems and shortcomings of science education which contributes to the superstitious state of the common people and to encourage to imbibe and internalize the method of science, prominently 'hands-on science' in such a way that it could relate teaching and learning techniques with real life situations. Recognising ground realities is a must. Recent government policies have concentrated on elementary education (though I feel it is more quantitative than qualitative) through the sarva shiksha Abhiyan and also on higher technical education (more its, aims, nits and more seats in the existing ones), science education with something new is nowhere in the agenda.

### Methods

Science education suffers from lack of lack of experimental facilities, absence of quality

teachers, inadequacies in curricula and lack of flexible subjects and course combinations. The environment or surrounding of every school is a ready-made source of objects, happenings and relationships to investigate. Thus even if a school has a few internal resources for active science, it is never short of an environment which can support a great deal of scientifically and educationally valuable activity.

#### A brief detail of 'The Hands-on science project for 20 schools:

District: Begusarai State: Bihar Year: 2008-09 No of Schools: 20

#### Regular Activities:

- Drawing up a plant profile
- Watering the plants of school garden
- Sky watching(once a week)
- Collection of insects(living and dead)
- Field visit
- Cleanliness drive(once a week)
- Debate/discussion/cultural activities every week
- Organising science meals for the scientific exposition of miracles in the feeder areas of the schools.

In the beginning of 2008 this project was organized for 20 schools. Taking all the odds – existing plight of govt. rural schools, the indifferent attitude of teachers and education on contract, into consideration, minimum activities were selected within means in terms of monitoring, orientation of teachers, running activities regularly and successfully. By and large, all the selected 20 schools continued the activities throughout the year despite adverse situations and circumstances. It is noteworthy that when the teachers were driven to non-academic work by the district administration, some students of higher classes took up the leadership and the activities continued.

Regular nurture and nourishment to the plants made the school lively, attractive and environmental-friendly bamboo fencing were arranged by the community. This paved a way to prepare plant profile and their nourishment. The local teachers were given the task of helping the children watch sky once a week. A fortnight meeting of resource teachers along with core group children was conducted on Sundays. To show the importance of any organism in an ecosystem and how various biotic and abiotic

components interact and affect each other, a small eco-pond and wormarium were also built up in the schools. The basic objective of these activities was to allow the participants to observe the behaviour of various living organisms in their natural habitat and to draw their own conclusions about their role in a particular eco-system. Once a week the local teachers and the community trainers devoted one hour to sky-watching. With the help of resource teachers children learned to identify various stars forming the shape of bear, lion, scorpion and man with arrow were really an amazing experience for them.

Active and important six months of the project witnessed the most interesting interaction of the student with local man, who as believed by the local people, had the ability of catching live snakes. He answered many queries raised by the children and confessed that he did not possess supernatural power. What he had was knowledge about the local snakes. According to him, most of the local snakes are not poisonous and also did not pose any danger to his life while he trapped them. It was decided in the beginning that two camps in a year would be organized. The first two-day camp was organized in May-2009. Five students from each school were selected for the camp. All the participants who were unknown to each other at the commencement of the camp within two days became intimate friends. Within two days, they had discovered new methods and approaches to learn about nature without the help of books. A new confidence was clearly visible on their faces. Believe it or not, this is a rare happening in the life of a government school.

Since I, the organizer of the project, have been displaced for some reasons as well as the teachers of the project, it is getting somewhat slow and non-responsive. Similar is the case with all such transitory projects for want of concrete footing in terms of established system.

In order to examine the positive impact of the activities of the project, a household survey of 2000 population of a remote village of downtrodden mass and municipal area of all the communities which was not covered under the project to examine the awareness with regard to some important aspects of life.

Figures in %

NECESSITY	WILLINGNESS TO OPT	INCOME GROUP RURAL			INCOME GROUP RURAL WILLINGNESS TO OPT			
		<Rs 3000	Rs 3000-5000	Rs 5000-8000	Rs 8000-10000	Rs 10000-15000	Rs 15000-30000	Rs 30000+
Treatment for Reproductive aspect	Doctors	17	22	48	56	59	50	48
Vastu Aspects	Vastuvid	0	0	0	72	85	89	91
For employment, marriage, settlement of litigations, etc.	Tantrik/ Astrologer	0	10	12	89	90	96	98
Performing Yagnas	Pandit Or Babas	0	15	17	97	98	99	99
Matching horoscopes	Astrologer	0	0	0	94	97	98	98

**Discussion and Observation:** Teaching outside the classroom was earlier not conceived by the teachers. They pretended it for want of time and took as an additional work. By organizing such a project, 'each one, plant one' got a momentum. A group of students with guide teachers started maintaining record register of plants. At present, the students are looking after their plants and observing their growth daily. This is a form of hands-on science. This project is an attempt in this direction by involving children in such activities which help them in understanding the environment around them and which would also help them to rehabilitate their environment and spread this message in the society in order to attract the common people towards science of nature.

The house-hold survey followed by the six-month tenure of the project highlights the income groups of the masses where the project was going on and the masses where there was no project. Rural income groups of the project area show their options in comparison to higher income groups of municipal areas. This survey underlines the fact that existing education alone cannot promote scientific and technological temper. Continuous and rigorous hands-on science activities are required for this.

## Conclusion

Facing embarrassments, ridicules, several impediments and possibly failures, this study of mine on hands-on science related to a project concludes:

- Joyful teaching-learning processes bind teachers and students in a meaningful rope.
- An activity makes the child think how to meet the challenge of 'doing', providing informal learning and motivates him/her to try.
- Activity-based teaching cannot be a part of regular classroom teaching is proved wrong.



- Coming of villagers to the teachers for scientific advice proves that they have been cut off from science.

- Using environment as a laboratory, innovative techniques in term of hands-on science can be adopted in inculcating scientific temper among students for a better quality of life. This will do a lot in the context of our situations and circumstances dominated by the have-nots of the society.

### Recommendations

- A bold step is required to challenge the orthodoxy of Indian Science Education..In all the schools, colleges, universities and science centres, science should be practiced. We must remember the Hoshangabad science Teaching Programme (HSTP) which started in 1972 as a pilot project in 16 schools of Hoshangabad district in Madhya Pradesh. At the time of its abrupt closure in 2002, it was running in around in 1000 schools in 16 districts of the state. The HSTP was unique in that it was a state programme, running in ordinary govt schools supported by a large academic resource group. Although no longer a running programme, the HSTP has had great influence on the discourse of education in the country. Such a model will meet the wider aims of science education. This is scientific science education.

- Every elementary school must have science curriculum of 60% hands-on 40% theory. This has to be implemented with a deep and strong sense of responsibility.

- A genuine provoking national debate on science education is a must. It must result in lighting the spark of the search for knowledge in the creative, fertile, adventurous minds of the young.

- Revamping Of science education is a must.

- At the elementary level of education, at least two science teachers in each and every school should be appointed through rigorous recruitment system which consists of missionary zeal, hands-on experiences and scientific bent of mind. They should be given special status in all respects.

- The undergraduate courses in India are to be made into 8-semester-course or a four year programme. During these four years the students are expected to go through not only lecture

classes, but spend a good bit of time in research/application/field work. Only 5 and some other Indian Institutes of Science Education and Research will not meet all the requirements of our country.

- Students of IITs and NITs must be sent to villages for at least six months for the promotion of scientific and technological temper.

- IITJEE and AIEEE top 10000 rank holders must be given basic science. 10000+ rank holders should be given engineering and other streams.

- Our formal system of science education from bottom to top should be tackled with strong will-power keeping this fact in mind that all the efforts for the promotion of scientific and technological temper has not given encouraging result even after more than a half century of independence.

---

---

## Effective Science Communication Practices and Simple Hands-on Activities: Two Important Elements of Teacher Professional Development

S. Perera

Centre for the Public Awareness of Science,  
The Australian National University,  
Canberra, Australia  
Sean.Perera@anu.edu.au

**Abstract.** Inquiry-based pedagogy remains a key reform recommendation for school science internationally. Many science teachers are, however, challenged by inquiry. Mounting evidence suggests two main reasons for teachers' reluctance towards this student-centred approach of instruction: a lack of a well grounded science knowledge base; and inadequate exposure to inquiry in practice. This paper presents qualitative evidence from Australian, Indonesian and Sri Lankan science teachers who participated in one-day professional development workshops that exemplified constructivist learning. The findings indicate that simple hands-on activities and effective science communication practices can help to foster inquiry.

**Keywords:** constructivism, hands-on, inquiry, professional development, science communication.

### 1. Introduction

The literature suggests that school science should yield outcomes beyond the confines of mere classroom learning [5],[8]. In fact, it is believed that school science is effective only when it is "linked with the broader community" [19, p.19] and when students are able to "generate fruitful and relevant questions and frame them in an effective way for investigation" [7, p.228]. Such a shift in emphasis, from traditional content-based instruction, requires science teachers to "focus more on the nature of science and on the evidence and arguments of scientific ideas, and help students develop skills of engaging in fruitful argumentation" [24, p.670]. Consequently, a key recommendation for science education reform internationally requires teachers in the classroom to emulate the

investigative processes of scientific inquiry [13], [16], [17], [22].

Despite the onus placed on student-centred inquiry, recent studies reveal that recommended pedagogy fails to feature in many science classrooms [20]. Instead, it is reported that teachers continue to employ traditional models of content transmission [15]. While the absence of inquiry in most science classrooms is lamented [2], it is irrefutable that teachers' reluctance to implement inquiry stems from the challenge it represents.

There are two predominating reasons for this reluctance. First, many teachers lack a well grounded science knowledge base with which to facilitate inquiry in the classroom. Second, only a few teachers have had sufficient exposure to scientific inquiry, and are aware of what it entails, to be able to use it in the classroom.

The lack of adequately developed knowledge about scientific concepts, particularly at tertiary level, is a deterrent to inquiry-based pedagogy. For example, it was found that 50% of Australian middle school science teachers did not have relevant university science qualifications [26]. This lack of well constructed knowledge structures is manifested in their disinclination towards inquiry. It also explains their discomfort to uncertainty, questioning and puzzlement that are inherent to inquiry-based pedagogy [4]. In such situations, it is reasonable for teachers to be prone to self-doubt [23], especially those who have not experienced science as a means of inquiring into the natural world [27].

Second, the limited exposure of teachers to inquiry at school and university prevents them from implementing pedagogical reform. In fact, their apprenticeship ingrains traditional models of teacher-centred instruction, dominated by content, which is far removed from inquiry-based pedagogy [14]. Many teachers teach as they have been taught [21], and if they are aware of inquiry-based pedagogy they remain oblivious about how to actually implement it in the classroom.

Professional development for teachers has long been used to complement education reform. Advocates insist that inquiry-based approaches that are grounded on constructivist learning experiences should also be employed in the professional development of teachers [17], [27]. This would enable teachers "to learn about science and science teaching with the same

methods and strategies as students should learn science in schools” [18, p.190]. This paradigm shift is deemed essential, as it would help teachers to construct confident understandings about science through personally meaningful learning experiences [10]. These understandings are necessary to implement inquiry-based pedagogy. Professional development based on inquiry would also offer teachers the opportunity to actively and collegially experience inquiry hands-on [6].

Studies fail to recognize, however, the potential for short-term professional development programs - essentially the one-day workshop model - to complement education reform. Only a few studies mention the possibility of exploring short-term professional development as a means to motivate teachers to adopt inquiry [18], [25]. This paper presents evidence from a qualitative study that explored this possibility.

## 2. Research study

The Centre for the Public Awareness of Science (CPAS) at the Australian National University, offers one-day workshops entitled “Creative Science Teaching Using Simple Materials” for secondary school science teachers in Australia and elsewhere. As their name implies, these workshops employ simple, readily-accessible equipment. They also draw on the science centre traditions of public engagement. Interviews with the workshop facilitators, early on in the study, confirmed that constructivist learning principles were used to design the workshop activities. I investigated six such workshops. I present here findings from interviews with a purposeful random sample of 38 teachers (19 Australian, 10 Sri Lankan, 9 Indonesian) who participated in those workshops.

I interviewed the teachers using a standardized open-ended interview format [11]. First, I asked them if they believed the workshops had informed their scientific understandings. The next series of questions probed how the workshops, if successful, informed those understandings.

## 3. Results and discussion

All 38 teachers agreed that the workshops informed their understandings. As two Australian teachers remarked:

“I came away with a really good package of stuff. And that wasn’t just sort of in-the-hand stuff, but in-the-head as well.”

“Yes it has benefited me because, obviously there are a few scientific concepts that I didn’t understand... the workshop has given me the mental tools, I guess, to be able to convey those concepts to the kids.”

It was evidenced from similar responses that the workshops succeeded in informing the teachers’ scientific understandings. Therefore, it was necessary to find out next how the teachers believed this was achieved in the workshops.

Interview findings highlighted two workshop features that played pivotal roles. The first of these, which all the teachers acknowledged, was the simple materials used in the workshop activities. They used words like “surprise”, “fascination” and “amazement” to describe these experiences. An activity known as the “Buoyancy see-saw” was described by one Sri Lankan as follows:

“I liked the two cups of water balanced on a strip of wood. When we put our fingers into the water we saw how pressure increased with depth. I was amazed how such a simple device could convey such a deep message.”

A reason behind the teachers’ appreciation of simple materials was their transferability to the classroom. In fact, it is believed that transferability of information should be an important element of teacher professional development [9]. As explained by an Indonesian teacher:

“Simple materials are easy to get and they are cheap... I think the students would be happy if we used simple materials. They would definitely be more interested in these than standard laboratory equipment that we normally use...”

As one Australian teacher explained further, simple materials are transferable because their workings are obvious to the students:

“I like hands-on stuff because you can actually see what happens. And I think it is the same with kids, they can see it happening.”

The teachers’ responses indicated that the simple hands-on activities informed their

scientific understandings in a similar way. As one Sri Lankan teacher remarked:

“The results of the experiments done that day were directly evident. All the experiments had definite observable results so it was possible to understand the fundamentals behind it.”

The teachers agreed that in order to teach science, they need to be confident about their own understandings. As another Sri Lankan teacher commented, experiences with hands-on activities had enabled such a level of confidence:

“... I could only completely understand the concept involved when I was able to experience it for myself. Until then I cannot explain this phenomenon to the student. I myself have to comprehend it first.”

Second, the teachers believed that effective science communication practices helped to inform their understandings during the workshops. In particular, their responses highlighted three such practices: use of narratives, simple dialogue-type delivery style, and animated communications.

The teachers believed that the use of anecdotes and stories rendered familiarity to the scientific concepts. In fact, a recent study states that narratives help to bridge between scientific and non-scientific speech [3]. As explained by one Australian teacher:

“I particularly remember what we were told about the movie Titanic, as a way of describing buoyancy... These stories of the real world helped to make links to science.”

Also, there were two or three facilitators present at each of the workshops. The facilitators interacted with one another while presenting to the teachers. The teachers appreciated this style of dialogue, particularly the way in which the facilitators freely discussed scientific concepts and critiqued each other. They pointed out, moreover, that the facilitators’ dialogue-type delivery style was effective because they chose to use simple, easy to comprehend language. As one Australian teacher remarked:

“The level of dialogue seems a good mix of academic, but at the same time what a general lay person can speak. They could have spoken at a very theoretical level, but they chose not to.”

The teachers found that the facilitators’ use of body language, voice intonation and theatrical devices animated their communications. By communicating science in such ways the facilitators conveyed (“almost infectiously” as

one Australian teacher stated) their enthusiasm and passion for science. The Sri Lankan and Indonesian teachers, in particular, for whom English was a second language, appreciated the facilitators’ animated communications because they crossed language barriers. As one Indonesian teacher described:

“I know enough English to understand what was said, but the body language, gestures, the way they moved their hands and their facial expressions, with these things the message got through much better.”

Eminent scientists, like Michael Faraday and Lawrence Bragg, have emphasised good delivery is paramount when communicating science to the public [1]. Their writings also recognise the importance of expression, simple language and simple experiments. In order to engage an audience, Faraday states that “it is necessary to pay some attention to the manner of expression. The utterance should not be rapid and hurried...but slow and deliberate, conveying ideas with ease from the lecturer and infusing them with clearness and readiness into the minds of the audience.” A more recent analysis of public physics lectures concur that narrative, visual-story and comprehensible language should form the framework of scientific discourses with the public [12]. The responses above, from teachers in the present study, indicated that science communication practices in the workshops played an important role in conveying scientific ideas effectively.

#### 4. Conclusion

This study offers evidence that professional development courses which incorporate simple hands-on experiments can offer science teachers much needed exposure to inquiry-based learning. Teachers were able to construct personally meaningful understandings about science. They were, therefore, more confident about their own scientific knowledge. This study also showed that science communication practices played an important role in such learning environments. They helped to build a bridge between science and commonplace events, making science more personally relevant to the teachers. Science communication practices also helped to transcend language barriers in the workshops for Sri Lankan and Indonesian teachers. These benefits of effective science communication

practices should not be limited only to the professional development of teachers. Opportunities to explore the potential of science communication in formal science education in the classroom are also needed.

## 5. Acknowledgement

I acknowledge Professors Susan Stockmayer and Michael Gore at and the Centre for the Public Awareness of Science, ANU for enabling the workshops and this study.

## 6. References

- [1] Advice to lecturers. An anthology taken from the writings of Michael Faraday & Lawrence Bragg. The Royal Institution of Great Britain. Author; 1986.
- [2] Australian Education Review: Re-imagining Science Education. Tytler R. Australian Council for Educational Research; 2007.
- [3] Avraamidou L, Osborne J. The role of narrative in science communication. *International Journal of Science Education* 2009; 31(12): 1683-1707.
- [4] Barnett J, Hodson D. Pedagogical content knowledge: Toward a fuller understanding of what good science teachers know. *Science Education* 2001; 85(4): 426-453.
- [5] Beyond 2000: Science education for the future. Millar R, Osborne J. King's College London School of Education; 1998.
- [6] Borko H. Professional development and teacher learning: Mapping the terrain. *Educational Researcher* 2004; 33(8): 3-15.
- [7] Burbules NC, Linn MC. Science education and philosophy of science: Congruence or contradiction? *International Journal of Science Education* 1991; 13(3): 227-241.
- [8] Changing the subject: Innovations in science, mathematics and technology education. Black P, Aitkin J. Routledge; 1996.
- [9] Cohen DK, Hill HC. Instructional policy and classroom performance: The mathematics reform in California. *Teachers College Record* 2000; 102(2): 294-343.
- [10] Designing professional development for teachers of science and mathematics. Loucks-Horsley S, Love N, Stiles KE, Mundry S, Hewson PW. Corwin Press; 1998.
- [11] Educational Research. Gall MD, Borg WR, Gall JP. Longman Publishers USA; 1996.
- [12] Kapon S, Ganiel U, Eylon BS. Explaining the unexplainable: Translated Scientific Explanations in public physics lectures. *International Journal of Science Education*; 2009. <http://www.informaworld.com/smpp/content~content=a907874773> [24.02.09]
- [13] Kurikulum 2004. Ministry of Education Jakarta. Curriculum Centre; 2004.
- [14] Lee C, Krapfl L. Teaching as you would have them teach: An effective elementary science teacher preparation program. *Journal of Science Teacher Education* 2002; 13(3): 247-265.
- [15] Lyons T. Different countries, same science classes: Students' experiences of school science in their own words. *International Journal of Science Education* 2006; 28(6): 591-614.
- [16] Ministerial Council on Education, Employment and Youth Affairs. Australia's common and agreed National Goals for Schooling in the twenty first century. *Curriculum Perspectives* 1999; 19(4): 8-9.
- [17] National Science Education Standards. National Research Council. National Academy of Science Press; 1996.
- [18] Posnanski TJ. Professional development programs for elementary science teachers: An analysis of teacher self-efficacy beliefs and a professional development model. *Journal of Science Teacher Education* 2002; 13(2): 189-220.
- [19] Primary Connections. Hackling MW, Prain V. Australian Academy of Science; 2005.
- [20] Rennie L, Goodrum D, Hackling M. Science teaching and learning in Australian schools: Results of a national study. *Research in Science Education* 2001; 31: 455-498.
- [21] Schoolteacher: A sociological study. Lortie D. The University of Chicago Press; 1975.
- [22] Science & Technology Curriculum. National Institute of Education Sri Lanka. National Institute of Education Press; 2004.
- [23] Shymansky JA, Henriques L, Chidsey JL, Dunkhase J, Jorgensen M., Yore LD. A professional development system as a

catalyst for changing science teachers.  
Journal of Science Teacher Education 1997;  
8(1): 29-42.

- [24] Simon S, Johnson S. Professional learning portfolios for argumentation in school science. International Journal of Science Education 2008; 30(5): 669-688.
- [25] Van den Berg E. Impact of in-service education in elementary science: Participants revisited a year later. Journal of Science Teacher Education 2001; 12: 29-45.
- [26] Who's teaching science? Meeting the demand or qualified science teachers in Australian secondary schools. Harris KL, Jensz F, Baldwin G. Australian Council of Deans of Science; 2005
- [27] Yager RE. The Constructivist learning model: Towards real reform in science education. The Science Teacher 1991; 67(1): 44-45.
- 
-

## Development of Soft and Hard Materials with Engineered Microstructures: Some Simple, Hands-on Techniques for Synthesis

G. Banerjee<sup>1</sup> and D. Sanyal<sup>2</sup>

<sup>1</sup>Department of Chemistry, Indian Institute of Technology Roorkee, Uttaranchal, INDIA

<sup>2</sup>Central Glass and Ceramic Research Institute, 196 Raja S. C. Mullick Road, Kolkata, INDIA

gourabbanerjee70@gmail.com;  
sanyald@gmail.com

**Abstract.** Materials science and engineering has undergone a major paradigm shift in recent times with an emphasis on developing smart, engineered materials with controlled microstructures for tailored functionalities and properties. Such engineered materials attract research interest for a wide gamut of advanced technological applications, such as, novel sensors and actuators, membranes for ultra- and nano-filtration, catalysts for reactors, solid electrolytes for solid oxide fuel cells (SOFC), thin films structures for photovoltaics, drug delivery systems, biomedical implants, microphotonics and so on. In recent years, many advanced techniques for fabrication of smart materials with engineered microstructures have been developed, such as, self assembly through hydrophobic interaction, lithography, reamineform technique, thermal reduction process etc. In this article, we present simplified techniques for synthesizing solid and hollow polymer microspheres which can be used for a variety of novel applications as sensors, drug delivery systems, pollution mitigation system etc. We also demonstrate use of these microspheres as templates for preparing ceramics with engineered pore structures which can be used as membranes, electrolyte for SOFC, catalysts etc. Hollow polymethyl methacrylate (PMMA) microspheres were fabricated using a density matched multiple water-oil-water (W/O/W) emulsion technique with and without polymerization reactions. Tailored surface properties of these polymer microspheres were achieved by a special solvent washing technique. The shape of the PMMA microspheres exhibited uniform sphericity and a monomodal/bi-modal size distribution depending

on various experimental parameters. Solid polyacrylamide (PAM) microspheres were synthesized by a simple sedimentation polymerization technique yielding monodispersed particles. The synthesis of ceramics with controlled porosity has been achieved in a template assisted synthesis with the help of polymer microspheres as templates and ceramic powder as target materials. In the present work, a polymer-ceramic core-shell structure was developed by creating suspensions of polymer and ceramic particles separately and mixing them together. The polymer-ceramic core-shell structure formed due to electrostatic attraction between the ceramic particles with suitable surface modification using appropriate surface active agent, such as, polyethylenimine and the oppositely charged polymer particles. The core-shell structure was filtered, dried and sintered to produce ceramics (e.g., alumina, titania) with controlled, spherical porous microstructure which is not achievable by any conventional ceramic processing technique.

### Introduction

Synthesis of homogeneous polymer microspheres of controlled size have been the object of attention for the last three decades due to a variety of novel industrial and research applications related to biomedical engineering, food processing, chemical synthesis, nanotechnology, microfluidics, microelectronics and so on. Such studies have been conducted with various objectives and end uses, such as, chromatography, ion exchange, coatings, calibration standards, immobilization of enzymes, solid state synthesis of protein, drug delivery, nuclear imaging, cell culturing etc. The overall performance of the systems in which these microspheres are used depend on a variety of properties of these microspheres, such as, particle size, size distribution, porosity and pore structure, surface area, swellability, mechanical strength, permeability, biocompatibility, reactive functional sites etc.

These polymeric microspheres can be synthesized in two forms – solid spheres and hollow spheres; the latter are sometimes known as microcapsules. Recently there is a renewed interest in preparing these hollow microcapsules for producing novel microreactors where synthesis of functional materials occur inside

these capsules. Alongside the developments of polymer microspheres, interesting and important research activities are being pursued for fabricating ceramic-polymer core shell structures primarily for producing ceramic structures with controlled porosity. The major impetus for such research comes from the biomedical applications, advanced sensor development, fabrication of microporous ceramic membranes for ultrafiltration of polluted water and industrial effluents, porous electrodes of solid oxide fuel cells etc. A variety of techniques have been applied to produce porous ceramic materials for the above mentioned applications, such as, replamineform process, use of foam producing or reactive agents which produce gases during calcinations and so on. However, most of these processes give rise to pores of random shape, size and orientations. Often such wide and random distribution of pores in the sintered ceramics, such as, alumina, silicon carbide, titania or hydroxyapatite do not yield an end product for the advanced biomedical, sensor, filtration or such other applications.

## Techniques Of Synthesis

### Synthesis of Microspheres

*Chemical Polymerization*

*Suspension Polymerization*

*Sedimentation Polymerization*

*Dispersion Polymerization*

*Distillation Precipitation Polymerization*

*Emulsion Polymerization*

### Synthesis of Porous Ceramics

*Powder Pressing and Sintering*

*Sol-Gel Process*

*Gelcasting Method*

## 1.1. Synthesis of Hollow PMMA Microspheres from Polymer Precursors

In the present method, a primary emulsion of water in oil (W/O) was dispersed in another aqueous phase which resulted in a water/oil/water (W1/O/W2) type emulsion.

Sodium lauryl sulphate (SLS) was used as the primary surfactant for preparing the W1/O type emulsion. Polyvinyl alcohol (PVA) was used as the second surfactant for preparing the multiple (W1/O/W2) type emulsion. The steps for preparing the hollow microspheres are described as follows:

(1) At first an equivalent mixture of 1,2 dichloroethane and benzene (99% pure) from E-Merck, Germany was prepared as a solvent for the poly(methyl methacrylate) (Av. Molecular Weight 120,000) powder from Sigma Aldrich, Germany. The selection of these solvents were dictated by the similar boiling temperature, temperature dependence of vapour pressure and latent heat of vapourization of these solvents which facilitate drying of these solvents without any change in density. The concentration of the oil phase was varied between 1 to 5 weight percent. For preparing the W1 phase, the primary surfactant, sodium lauryl sulphate (90% pure) from E-Merck, Germany was added to the aqueous phase in concentration range of 0.1 to 1.0 weight percent. The second water phase W2 was prepared by adding PVA (Average Molecular Weight 125000, 86.0 to 89.0 % hydrolysis) from S. D. Fine- Chem Ltd., Mumbai, India. In the concentration range 2 to 5 weight percent. (2) The W1/O emulsion was prepared by mixing 2 to 10 ml of aqueous solution of SLS in 50 ml of oil phase with the help of mechanical stirring for 15 minutes followed occasionally by magnetic stirring for about 15 minutes. The concentration of the SLS was allowed to vary from 0.3 weight percent to 2.0 weight percent. The concentration of SLS was found to affect the formation of microsphere.

(3) The W1/O emulsion was poured in the second emulsion comprising W2 phase.

The volume of the second emulsion was varied in the range 10 ml to 100 ml. stirring was done to obtain well dispersed droplets of double emulsion. The volume of the second emulsion also had a considerable effect on the formation and quality of the microsphere.

(4) The hollow microsphere was finally obtained from the W1/O/W2 double emulsion by drying in an air oven at a temperature between 60 to 70 °C for removal of the solvent. The duration of drying was varied between a couple of hours to up to 24 hours under ho condition, followed by 24 to 48 hours under ambient conditions.



### 1.2. Synthesis of Hollow PMMA Microspheres by Crosslinking of Co-monomers

An alternate was also attempted in the present work by starting from a precursor comprising PMMA and a multifunctional co-monomer - dibutyl phthalate (DBP). For initiation and crosslinking of the free radical emulsion polymerization, benzoyl peroxide (BPO) and N, N'-methylenebisacrylamide (MBAM) were used in varying proportions. Typically, for 0.1. The W1/O/W2 double emulsion was prepared in the same manner as described in the previous section. For cross-linking and polymerization, the double emulsion was heated in a constant temperature bath (manufactured by M/S S. C. Dey & Co., Kolkata) to a temperature in the range 55 to 65 oC where the temperature was maintained isothermally with an accurate PID controller with  $\pm 0.5$  to 1% accuracy in the range ambient to 150 oC. The hollow PMMA microspheres formed after crosslinking and polymerization were obtained by drying in the same fashion as described in the preceding section.

### 1.3. Surface modification of PMMA microspheres

In case of PMMA microspheres which were synthesized from polymer precursor by the double emulsion technique without any polymerization, it was found that the drying process occasionally failed to yield microspheres with requisite property.

Moreover, as the solvent evaporation took a considerably long time – between 24 to 72 hours – it was felt that a technique for achieving surface hardness of the microsphere during its synthesis was necessary to curtail the synthesis time and impart adequate strength to the microspheres. In the present work, we used organic chemicals, such as, acetone, benzene, toluene etc. for modifying the surface of the microspheres formed in the double emulsion process and 0.5 to 1 ml of acetone was added to the emulsion system during formation of microspheres. The rest of the procedure was similar as in section 1.1.

### 1.4. Synthesis of Solid PAM Microspheres by Sedimentation Polymerisation

Solid polyacrylamide (PAM) microspheres were synthesized in the present work using a sedimentation polymerization route. 10 mmol (0.71 gm) of Acrylamide (99%) monomer of E-Merck, Germany and 1 mmol (0.154 gm) of MBAM cross-linker were dissolved in an aqueous solution of 98% pure ammonium persulphate, (NH<sub>4</sub>)<sub>2</sub>S<sub>2</sub>O<sub>8</sub> of E-Merck, Germany (0.01gm in 5 ml of water). The monomer-crosslinker-initiator precursor solution was introduced by syringe as droplets to a heated bath of light paraffin oil kept in a perspex cavity of 35 mm x 35 mm cross-section and 250 mm height. The temperature of the oilbath was maintained in the range of 85 to 90 oC. The height of the cavity was decided on the basis of sedimentation time for the droplets to settle at the bottom. Typically a sedimentation time of 5-7 seconds ensured that partial gelation of the drops takes place. This prevented coalescence of the drops at the bottom of the cavity. Further cross-linking and polymerization of the partially gelled droplets deposited were then allowed to occur for approximately 2 hours at 50 oC.

### 1.5 Synthesis of Microporous Ceramics

The polymer microspheres synthesized as above has been used as templates for preparing porous ceramics with controlled shape and size of the pores. A core shell polymer-ceramic structure was formed as follows. Spherical PMMA powders with size varying in the range 60  $\mu$ m to 500  $\mu$ m in diameter which were synthesized in the present work were used as template materials. Alumina ceramic powders (Al<sub>2</sub>O<sub>3</sub> A16SG of Alcoa) with BET area 8.5 m<sup>2</sup>/gm and titania powders (TiO<sub>2</sub>, E-Merck) were used as ceramic building blocks. For preparing the core-shell structure Polyethylenimine (PEI) of Fluka with molecular weight in the range 600000 to 1000000 was used for surface modification of the ceramic particles.

In a typical synthesis of porous alumina ceramics, a dispersion of 5 gms of Al<sub>2</sub>O<sub>3</sub> powder in 95 ml of double-distilled water was prepared using 0.1 ml – 0.5 ml of PEI to maintain a pH of 8. PEI acted as a cationic dispersant to impart surface

modification of the alumina powder such that a highly positive surface charge potential

developed in the alumina powders. For preparing a stable dispersion, the mixture was ultrasonicated followed by magnetic stirring, each for 15 minutes duration. 0.5 gm of PMMA polymer particles were dispersed in 25 ml of water and 0.1 – 0.5 ml formic acid was added to maintain a pH of 4 such that the PMMA particles became negatively charged. The PMMA suspension was also ultrasonicated and magnetically stirred for achieving a stable dispersion. The Al<sub>2</sub>O<sub>3</sub> suspension was then mixed with the PMMA suspension and the resulting solution was stirred for 20 minutes. The oppositely charged polymer and ceramic particles attracted each other to form the polymer-ceramic core-shell structure. The resulting mixture was filtered and dried in an air oven at 70 oC for 24 hours to obtain a solid polymer-ceramic core-shell structure which upon sintering produced ceramics with

## 2. Results and discussion

In this section we summarize the effects of various processing techniques described in sections 1.1 to 1.3 for synthesis of porous PMMA microspheres and the synthesis of template assisted porous ceramics as described in section 4.5. In the early stage of preparation of the double emulsion process, the PMMA microspheres, formed after injection from syringes with needles of various sizes (diameters – 0.545 mm, 0.7 mm, 0.9 mm etc.), accumulated in the petridish or beaker as floating liquid mass. The image is taken from a Video camera mounted on an Olympus SZX7 Stereozoom optical microscope. The dual water-oil phases in the sphere are clearly visible in the central sphere.

After sufficient residence time for drying and solvent evaporation, the size of the resulting microspheres would change considerably. Typically, from a precursor comprising 1% PMMA solution of 20 ml, 0.8% Lauryl sulphate solution of 0.5 ml and 1% PVA solution of 10 ml, the resulting PMMA microspheres obtained after solvent evaporation for 44 hours.

Because of the long time required in solvent evaporation and the associated size reduction of hollow PMMA microspheres, two alternatives for synthesis were attempted (a) synthesis of PMMA by cross-linking (section 1.2) and (b)

surface modification of PMMA by acetone washing (section 1.3).

In a typical study pertaining to cross-linking of co-monomers by benzoyl peroxide (B.P.O), 1% PMMA (25 ml), 1% Lauryl Sulphate (0.5 ml) and 2% B.P.O. solution was taken in a syringe (with 0.9 mm dia needle) in 6 ml quantity and was injected to PVA(300 ml) in a beaker. The mixture was heated to 62 oC for approximately 6 hours.

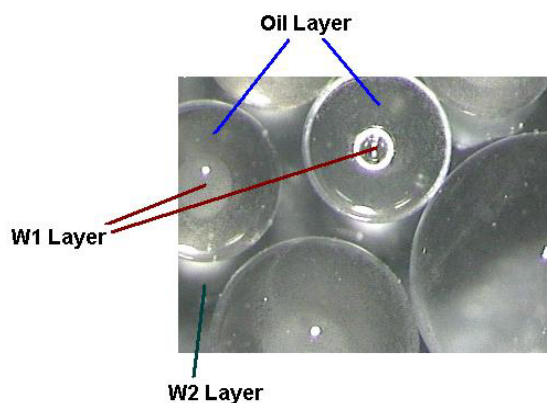


Figure 1 Liquid PMMA spheres floating in double emulsion

In this process, the cross-linking imparted adequate surface hardness, but at the cost of transparency of the spheres. The processing time got drastically reduced from 48 hours to 6 hours. A simpler, room temperature surface modification technique was attempted by washing the PMMA microspheres after their initial formation by acetone washing as described in section 1.3. The concentration of acetone was found to have its effect on the quality of surface modification. The PMMA microspheres which are shown were formed by drawing 1 ml solution of 1% PMMA and lauryl sulphate in a syringe with 0.545 mm dia needle and mixing it with 0.5 ml acetone before injecting to PVA in a petridish. Then using the same needle solution was sucked up and transferred to a beaker. Evaporation of the solvent yielded the microspheres. It is evident that the surface modification did not occur throughout the spherical surface and was confined to certain zones as evident from the localized zones of opacity.

The level of surface modification in this case was higher than that for 0.5 ml acetone. A third sample was prepared from a precursor comprising 1% PMMA (25 ml), 1% Lauryl Sulphate (0.5 ml). The precursor was mixed with

2.5 % acetone in a petridish. After solvent evaporation for 12 hours, the surface modified PMMA microspheres obtained. Two other interesting effects of surface modification by acetone washing observed in the present study are (a) prevention of coalescence and retaining the size distribution (b) self assembly of microspheres in an ordered structure.

Unlike the PMMA microspheres with unmodified surface, the surface modified PMMA spheres were not prone to break up as the lauryl sulphate was washed out with distilled water to facilitate rapid evaporation of solvent. The surface modification due to acetone washing imparted a solid skin and prevented coalescence or break up. This also allowed preservation of the original size distribution of the PMMA spheres. Also, it was observed that the spheres tended to self-assemble into an ordered technique described in sections 1.1 to 1.3 are shown in Figure 2 as histograms.

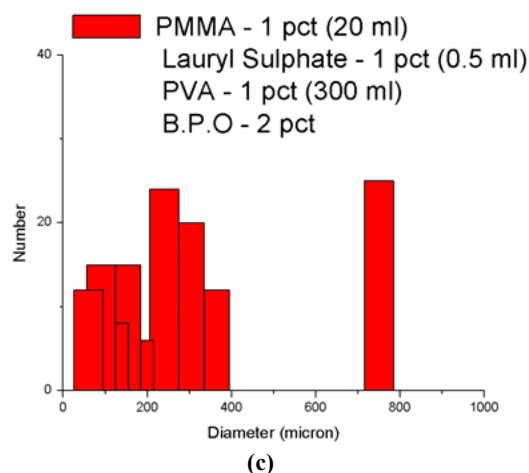
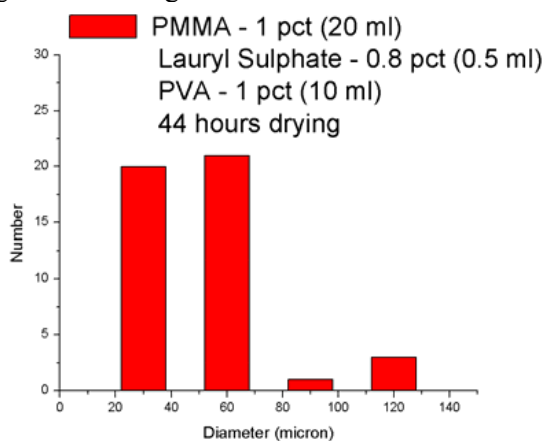
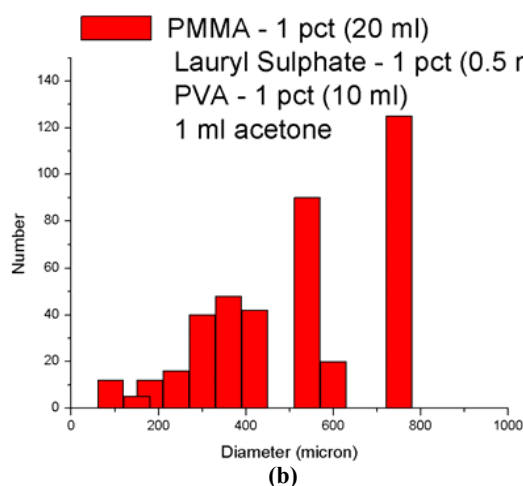


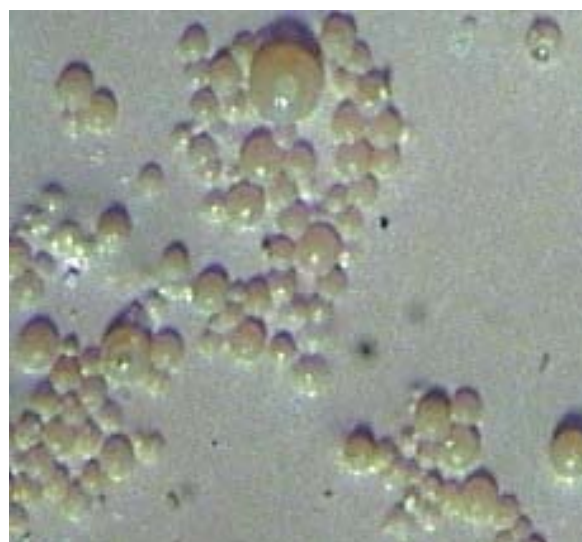
Figure 2 Histograms for size distribution of PMMA microspheres synthesized (a) without crosslinking (b) with acetone washing (c) with crosslinking by BPO



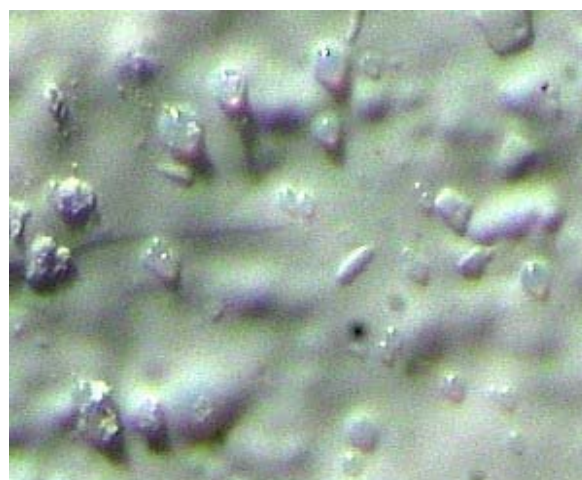
(a)



(b)



(a)



(b)

Figure 3 depicts the polymer-ceramic core-shell structure synthesized in this work.

From these histograms, it is observed that while surface modification and structure crosslinking leads to a rapid synthesis of PMMA microspheres, the spheres have a wide range of size distributions compared to the microspheres synthesized without any crosslinking or surface treatment. In the latter case, the PMMA microspheres have a bimodal distribution in the range 30-60 microns.

With the help of the PMMA microspheres synthesized as above, core-shell structures of alumina and titania were prepared as described in section 1.5.

### Acknowledgement

I would like to acknowledge the guidance of my supervisor Dr. D. Sanyal and the support of Director, CG&CRI and Head, NOCCD and A. R. Mollah, Scientist, Glass Division, CG&CRI during this work.

### References

- [1]. S. Voyutsky, Colloid Chemistry, Mir Publisher, Moscow (1978)
  - [2]. J. Yano, K. Sanada, R. Patil, Y. Ooyama, K. Komaguchi, Y. Harima, Materials Chemistry and Physics, vol:106, pp 279-285 (2007).
  - [3]. Tuncel, K. Ecevit, K. Kesencil and E. Piskin, J. Polymer Sc., Part A, vol:34, pp. 45-55 (1996).
  - [4]. E. Ruckenstein and L. Hong, Polymer, vol:36, pp. 2857-2860 (1995).
  - [5]. D. Horak, F. Svec and J. M. J. Frechet, Journal of Polymer Science, Part A, vol:33, pp. 2329-2338 (1995).
  - [6]. F. Bai, B. Huang, X. Yang and W. Huang, Polymer, vol:48, pp. 3641-3649 (2007).
- 
- 

## Physics Models to Estimate Averages and Errors on Quantities Used in Economics

I.R. Chisleag Losada<sup>1</sup> and R.Chisleag<sup>2</sup>

<sup>1</sup>National School of Political and Administrative Studies,  
Bucharest, ROMANIA

<sup>2</sup>University "POLITEHNICA",  
Bucharest, ROMANIA  
chisleag@gmail.com

**Abstract.** The values,  $x_j$ , of the quantities,  $X_j$ , used in macro-economic accounting, based upon: statistics, evolution models, laws, market projections and even on common sense, are considered relatively exactly known, but with values expressed up to 1k – 1M monetary units (\$, £, €, Rs, RON).

Being used in the text of a Law (f. e. in a National Budget Law), these values are supposed to be trustworthy and binding. A similar assumption is valid for the figures used in the documents at the micro-economic level (of companies a.s.o.), but with figures expressed more detailed, in monetary units, f. e. Frequently, their users are not even aware that they are using averaged values, not the actual (true) values.

The primary quantities,  $X_j$ , are, more or less exactly known, with errors  $s_{x_j}$ , on the values  $x_j$ . The values  $x_j$  of these primary data,  $X_j$ , are used to obtain some derivate quantities,  $F_k = F_k(X_1, X_2, \dots, X_j, \dots, X_n)$ , like, in Macro-economics, yearly: gross domestic product,  $P$ ; government revenues,  $R$ ; government spending,  $E$ ; budget deficit,  $D$ , defined as  $D = [(E - R) / P]$ ; other synthetic indices. They are, later on, largely used, at local, national or international levels, by decision makers, party leaders, media a.s.o. which refer to them and eventually, act based on them.

The functions defining derivate quantities are supposed to be exactly known, as well as their values, ignoring the existence of absolute errors  $s_{x_j}$  on the average values,  $x_j$ , of the quantities  $X_j$ .

The errors in basic quantities  $s_{x_j}$  propagate to the derived quantities, by the compounding of errors, subject to mathematical (and physical) formula, possibly leading to misinterpretation of derived quantities (functions). Sometimes, the errors values  $s_{F_k}$  on the functions  $F_k$ , might be

larger than the values  $f_k$  of the functions themselves, particularly for functions defined as differences of other functions and specifically, during crisis periods when there are a fast, less predictable, evolution.

How reliable are the values  $f_k$  of derivate quantities  $F_k$  and how large are the absolute errors  $s_{fk}$  of  $f_k$  in the forecasts, projections a. s. o. included in such binding documents – laws?

The current financial (particularly, accounting) practice (at least in Romania), does not offer a satisfactory answer about the reliability of projections at the instants the law is drafted, passed, signed and started to be implemented, in spite of the provisions of law being supposed to be compulsory.

Generally speaking, any figure in accounting is subjected to errors. How to estimate them?

In the paper, there are developed some models to evaluate averages and errors on quantities used in Economics, particularly in Macro-economics, based upon the sets of data collected, models based upon techniques used in processing Experimental Physics data, as to further develop the existing current mathematical models, based on figures (dimensionless), used in the preparation of a Budget and on a larger scale, in accounting.

The mean, average, middle, expected or central tendency of a data set replaces the true, actual, unknown value. The average is calculated by combining the readings related to a data set and computing a number as being the average of the set. There are many different descriptive statistics that can be chosen as a measurement of the central tendency of the data items. In the paper, there are defined: the median (used most often to describe house prices and incomes), mode; the: arithmetic (the most common), geometric (used to compute average percentage return), harmonic, quadratic (Root-Mean-Square), weighted and truncated means.

The systematic, random and rough errors are precisely defined considering: instrument and procedural errors, faulty process of processing the data and the personal bias.

There are introduced the standard deviation, the relationship between standard deviation and mean, the confidence interval; the standard error of the mean (SEM) and shown how to decrease the uncertainty in obtaining a mean value estimate.

There are introduced formulae to be used to compute propagation of uncertainty (or propagation of error) as an effect of variables' uncertainties (or errors) on the uncertainty of a function based on them, considering the variance-covariance matrix on  $x_j$ .

Some of the introduced models to estimate systematic and random errors are checked, being applied, specifically, for forecasted State Budget Law figures, to make a concrete analysis of the forecast on the **D**, Deficit of the Romania Budget, in Romania, in 2009. The analysis starts with the figure provided for in the Romania Budget Law, No.18/26.01.2009: **D** = **(E – R)/P=2.06 %**. There have been consulted the forecasts of experts on the evolution in 2009 of the Budget parameters as of March 15, 2009 and computed: the absolute linear error,  $\Delta D$  [

$$\Delta D = \frac{1}{P} (\Delta E + \Delta R + D * \Delta P)$$
 ], found to be **9%** and the standard error **S<sub>D</sub>**, [ 
$$S_D^2 = \frac{1}{P^2} * (S_E^2 + S_R^2 + D^2 * S_P^2)$$
 ], found to be **6.5%**.

The revised official forecast for the **D** in 2009, as of September 1, 2009, based on the evolution of the economy in the first 2009 and after receiving a loan from IMF, is **7.3%**, figure **covered** by the models used by the authors. A new check is due on final, actual, 2009 economic data, in March 2010.

---

---

---

## Sonochemical aldol condensation using copper perchlorate as catalyst in solventless media

S. Puri<sup>1</sup>, B. Kaur<sup>1</sup>, A. Parmar  
and H. Kumar<sup>2</sup>

<sup>1</sup>Department of Chemistry, Punjabi University, Patiala-147002 (Pb.), INDIA

<sup>2</sup>Department of Chemistry, Sant Longowal Institute of Engineering & Technology, Longowal-148106 (Pb.), INDIA  
choprahk67@gmail.com

**Abstract.** Copper perchlorate has been found to be new and highly efficient catalyst for aldol condensation of aldehydes and ketones under solventless conditions, at room temperature. The reaction is rapid, clean and eco-friendly for the synthesis of variety of 1,3-diaryl-2-propenones. Use of ultrasound irradiation helped in increasing reaction yield and decreasing reaction times.

**Keywords:** 1,3-diaryl-2-propenones, copper perchlorate, aldol condensation; 1,4 Michael adduct.

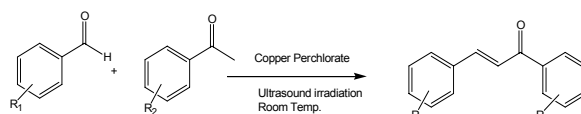
### 1. Introduction

Chalcones (1,3-diaryl-2-propene-1-ones) are natural substances found in a number of plants or synthetically prepared. These compounds are of a high attention due to their use as starting materials in the synthesis of a series of heterocyclic compounds [1–4]. The main method for the synthesis of chalcones is the classical Claisen-Schmidt condensation in the presence of aqueous alkaline bases. They are obtained also via the Wittig reaction [5], by the Friedel–Crafts acylation with cinnamoyl chloride, or photo-Fries rearrangement of phenyl cinnamates [6]. The aldol reaction is performed also under acidic medium, using HCl, BF<sub>3</sub>, B<sub>2</sub>O<sub>3</sub>, p-toluenesulfonic acid, etc. [6]. The most common method applies ethanol saturated with HCl. The yields are low and vary between 10% and 40% [7]. There are many solid basic catalysts that have been applied in the synthesis of chalcones, such as MgO [8], hydrotalcites [9–11], natural phosphates

modified with NaNO<sub>3</sub> or KF [12–15], metal doped carbon catalysts [16,17] and

aminopropylated mesoporous silica [18,19]. Even though these reactions provide advantages due to its heterogeneous nature, the major drawback is associated with poor selectivity to chalcone in strong basic conditions. To improve the selectivity in synthesis of chalcones, solid acid catalysis has been tried, but only few have been reported [20]. Ultrasonic irradiation leads to the acceleration of numerous catalytic reactions as well as in homogeneous and heterogeneous systems [21] and significant improvements can be realized with regards to the yields [22–30]. The sonochemical phenomena originate from the interaction between a suitable field of acoustic waves and a potentially reacting chemical system; the interaction takes place through the intermediate phenomenon of the acoustic cavitation. Recently, the alkane sulfonic acid group functionalized ionic liquids were reported offering a new possibility for developing environmentally friendly acidic catalysts due to the combination of the advantages of liquid acids and solid acids, e.g. uniform acid sites, stability in water and air, easy separation and reusability [31].

In continuation of our work to develop new and eco-friendly synthetic methodologies [32,33] here we wish to report synthesis of chalcones using copper perchlorate as catalyst under ultrasound irradiation. To best of our knowledge, there are no earlier reports of copper perchlorate catalyzed synthesis of 1,3-diaryl-2-propenones under ultrasound irradiation in solventless conditions.



**Scheme 1.** Copper perchlorate catalyzed synthesis of 1,3-diaryl-2-propenones in solventless conditions under ultrasound irradiation

### 2. Results and discussion

Chalcones are commonly synthesized via the Claisen–Schmidt condensation. This reaction is catalyzed by acids and bases under homogeneous conditions. Our aim was to use copper perchlorate as catalyst for synthesis of 1,3-diaryl-2-propenones (**Scheme 1**) in good yields and shorter reaction times using substituted aromatic aldehydes and a broad variety of ketones.

The reaction was optimized using 4-methoxyacetophenone and 4-

methoxybenzaldehyde as model substrate in presence of different amounts of catalyst copper perchlorate (Table 1). The best results were obtained with 20 mol% of catalyst copper perchlorate. Excess of catalyst (40-60%) caused increase in rate of reaction but side products like 1,4 Michael adducts were formed.

Entry	Cu(ClO <sub>4</sub> ) <sub>2</sub> mol%	Time(min)	Yield (%)
1.	5	90	45
2.	10	80	60
3.	15	70	75
4.	20	60	93

Table 1: Effect of amounts of catalyst copper perchlorate on synthesis of 1,3-diaryl-2-propenones.

Entry	Cu(ClO <sub>4</sub> ) <sub>2</sub> mol%	With Sonication	Without Sonication
		Yield (%) Time(min.)	Yield (%) Time(min.)
1.	0	Nil	Nil
		150	360
2.	5	15	5
		110	360
3.	10	30	20
		95	360
4.	15	65	28
		65	300
5.	20	95	32
		45	300
6.	40	65	26
		40	300

Table 2: Effect of amounts of catalyst copper perchlorate with or without sonication for synthesis of 1,3-Bis-(4-methoxyphenyl)-propenone.

The reactions were performed with variety of aldehydes and ketones at room temperature using ultrasound irradiation. Copper perchlorate was found to be one of efficient Lewis acid catalyst in terms of lesser reaction times and good yields (Table 3).

E ntry	Pro ducts	Ald ehy de	Keto ne	Tim e(mi n.)	Yiel d (%)	M.P t. <sup>o</sup> C
1.	1a	Ph	Ph	50	93	57-58
2.	1b	4-OMe	4-OMe	45	95	103
		ePh	Ph			104
3.	1c	2-C <sub>4</sub> H	4-OMe	90	75	44-
						46

4.	1d	3O Ph	4-OMe	110	68	188
		ePh				h
5.	1e	Nap	4-OMe	105	89	149
		thyl				Ph
6.	1f	Ph	4-OMe	60	95	74-
						Ph
7.	1g	2-NO <sub>2</sub>	Ph	60	89	132
		Ph				
8.	1h	3-NO <sub>2</sub>	Ph	110	92	142
		Ph				
						143

Table 3: Copper perchlorate catalyzed synthesis of 1,3-diaryl-2-propenones in solvent less conditions under ultrasound irradiation.

Here in this reaction copper perchlorate acts as Lewis acid. It helps in formation of enolate intermediate by adding to the carbonyl carbon of aryl ketone which resulted in differently colored transition state (depending on aryl ketone). Also copper perchlorate added to carbonyl group of aryl aldehyde which helped in increasing electrophilic nature of carbon. After the intramolecular attack of enolate ion and dehydration gives the desired product in good yields.

Copper Perchlorate catalysed synthesis of chalcones generates specifically (E)-isomer. Presence of (E)-isomer was confirmed by value of coupling constant. (J = 15.50-15.60 Hz). The formation of products was confirmed by comparing the melting points, IR and NMR data with authentic samples and literature data (Table 4).

Entry	Products	PMR(CDCl <sub>3</sub> ) δ	IR (cm <sup>-1</sup> )
1.	1a	7.81-7.65(m, 5H, Ar-H);	1658, 1585
		7.82 (d, 1H, =CH); 7.50 (d, 1H, =CH);	
2.	1b	7.10-7.32 (m, 5H, Ar-H);	1654, 1594.
		8.05 (d, 2H, Ar-H); 7.82 (d, 1H, =CH);	
		7.62 (d, 2H, Ar-H); 7.47	

3.	1c	(d, 1H, =CH); 7.00 (t, 4H, Ar-H); 3.88 (s, 3H, -CH <sub>3</sub> ); 3.85 (s, 3H, - CH <sub>3</sub> ) 8.06 (d, 2H, Ar-H); 7.63 (d, 1H, =CH); 7.51 (d, 1H, =CH); 7.49 (d, 1H, =CH); 6.99 (d, 2H, Ar-H); 6.70 (d, 1H, =CH); 6.50 (s, 1H, =CH); 3.87 (s, 3H, -CH <sub>3</sub> ); 7.99 (d, 2H, Ar-H); 7.78 (d, 1H, =CH); 7.60 (d, 2H, Ar-H); 7.41 (d, 1H, =CH); 6.93 (d, 4H, Ar-H); 5.58 (brs, 1H); 3.86 (s, 3H, - CH <sub>3</sub> ); 8.64 (d, 1H, =CH); 8.27 (d, 1H, Ar- H); 8.09 (d, 2H, Ar-H); 7.93-7.88 (m, 3H, Ar-H); 7.63 (d, 1H, =CH); 7.59- 7.49 (m, 3H, Ar-H); 7.00 (d, 2H, Ar- H); 3.89 (s, 3H, -CH <sub>3</sub> ); 8.02 (d, 2H, Ar-H); 7.78 (d, 1H, =CH); 7.60 (d, 2H, Ar-H); 7.49 (d, 1H, =CH); 7.05-7.22 (m, 5H, Ar-H); 3.86 (s, 3H, - CH <sub>3</sub> )	1656,1600.	7.	1g	8.35 (d, 1H, =CH); 8.10- 7.85 (m, 4H, Ar-H); 7.65 (d, 1H, =CH); 7.58-7.40 (m, 5H, Ar-H); 8.01 (d, 1H, =CH); 7.95- 7.74 (m, 4H, Ar-H); 7.69 (d, 1H, =CH); 7.56-7.42 (m, 5H, Ar-H);	1652,1588,1330
4.	1d	3371,1654,1583.	8.	1h	1654,1589,1335		
5.	1e	1654,1600	<p><b>Table 4: NMR and IR spectral data of 1,3-diaryl-2-propenones <u>3a-h</u>* in solvent less conditions under ultrasound irradiation.</b></p> <p>*All the compounds gave satisfactory C, H, N analysis</p> <p><b>3. Experimental</b></p> <p>All melting points recorded are uncorrected, open capillary measurements, using sulphuric acid bath. IR spectra were recorded using KBr pellets on a Perkin-Elmer spectrophotometer, NMR spectra on AL-300F (Bruker) FT NMR spectrophotometer using tetramethylsilane (TMS) as internal standard. Sonication was performed in ELMA, Transsonic T 310/H Ultrasonic cleaner (with a frequency of 35 KHz), Hans Schmidbauer GmbH &amp; Co., Germany. The reactions were performed in open vessels.</p> <p><b>3.1. Synthesis of 1,3-diaryl-2-propenones, General Procedure</b></p> <p>Aromatic aldehyde (1.0mmol) and aromatic ketone (1.0mmol) were mixed together in a beaker followed by addition of Cu(ClO<sub>4</sub>)<sub>2</sub> (20 mol%). The reaction mixture was kept in ultrasound bath at room temperature for time as shown in <b>Table 3</b>. The progress of reaction was monitored by TLC. After completion of reaction the reaction mixture was quenched with ice cold brine solution and then extracted with ethyl acetate solution. The combined ethyl acetate layer was dried over sodium sulphate, filtered and evaporated under reduced pressure to give the crude product. The crude product was recrystallized by hot ethanol to give analytically pure samples of product.</p>				
6.	1f	1656,1590					



*1,3-Bis-(4-methoxyphenyl)-propenone* (Table 3 , Entry 2) - Melting Point – 103-104 °C. IR (KBr, cm<sup>-1</sup>) 1654, 1594.; <sup>1</sup>H NMR (300 MHz, CDCl<sub>3</sub>) δ 8.05 (d, 2H, Ar-H); 7.82 (d, 1H, =CH); 7.62 (d, 2H, Ar-H); 7.47 (d, 1H, =CH); 7.00 (t, 4H, Ar-H); 3.88 (s, 3H, -CH<sub>3</sub>); 3.85 (s, 3H, -CH<sub>3</sub>).

#### 4. Conclusion

In conclusion, the synthesis of 1,3-diaryl-2-propenones was successfully carried out in solventless media using copper perchlorate as catalyst at room temperature under ultrasound irradiation. The method offers several significant advantages, such as, high yields, easy handling, and cleaner green reaction profile which make it a useful and attractive method for the efficient synthesis of 1,3-diaryl-2-propenones.

#### References

- [1] B.A.Bhat, K.L.Dhar, S.C.Puri, A.K.Saxena, M.Shanmugavel, G.N.Qazi, Bioorg. Med. Chem. Lett. 15 (2005) 3177.
- [2] S.Wang, G.Yu, J.Lu, K.Xiao, Y.Hu, H.Hu, Synthesis (2003) 487.
- [3] X.Wei, J.Fang, Y.Hu, H.Hu, Synthesis (1992) 1205.
- [4] F.L.Ansari, S.Umbreen, L.Hussain, T.Makhmoor, S.A.Nawaz, M.A.Lodhi, S.N.Khan, F.Shaheen, M.I.Choudhary, A.Rahman, Chemistry & Biodiversity 2 (2005) 487.
- [5] C.Xu, G.Chen, X.Huang, Org. Prep. Proced. Int. 27 (1995) 559.
- [6] D.N.Dhar, The Chemistry of chalcones and related compounds, John Wiley & Sons, New York, 1981.
- [7] J.F.Miquel, Bull. Soc. Chim. Fr. (1961) 1369.
- [8] S.C.Hargrove-Leak, M.D.Amiridis, Catal. Commun. 3 (2002) 557.
- [9] M.J.Climent, A.Corma, S.Iborra, Primo, J. J. Catal. 151 (1995) 60.
- [10] M.J.Climent, A.Corma, S.Iborra, A.Velty, J. Catal. 221 (2004) 474.
- [11] A.Guida, M.H.Lhouty, D.Tichit, F.Figueras, P.Geneste, Appl.Catal. A 164 (1997) 251.
- [12] S.Sebti, A.Solhy, R.Tahir, S.Abdelatif, S.Boulaajaj, J.A.Mayoral, J.I.Garcia, J.M.Fraile, A.Kossir, H.Oumimoun, J. Catal. 213 (2003) 1.
- [13] S.Sebti, A.Saber, A.Rhihil, R.Nazih, R.Tahir, Appl. Catal. A: General 206 (2001) 217.
- [14] S.Sebti, A.Solhy, R.Tahir, S.Boulaajaj, J.A.Mayoral, J.M.Fraile, A.Kossir, H.Oumimoun, Tetrahedron Lett. 42 (2001) 7953.
- [15] D.J.Macquarrie, R.Nazih, S.Sebti, Green Chem. 4 (2002) 56.
- [16] V.Calvino, M.Picallo, A.J.Lo'pez-Peinado, R.M.Marti'n-Aranda, C.J.Dura'n-Valle, Appl. Surf. Sci. 252 (2006) 6071.
- [17] C.J.Dura'n-Valle, I.M.Fonseca, V.Calvino-Casilda, M.Picallo, A.J.Lo'pez-Peinado, R.M.Marti'n-Aranda, Catal. Today, (2005)107–108.
- [18] X.G.Wang, Y.H.Tseng, J. C.C.Chan, S.Cheng, J. Catal. 233 (2005) 266.
- [19] X.G.Wang, Y.H.Tseng, J. C.C.Chan, S.Cheng, Micro. Meso. Mater. 85 (2005) 241.
- [20] S.Shylesh, P.P.Samuel, Ch.Srilakshmi, R.Parischa, A.P.Singh, J.Mol. Catal. A, 274 (2007) 153.
- [21] R.Miethchen, Ultrasonics 173 (1992).
- [22] L.H.Thompson, L.K.Doraiswamy, Ind. Eng. Chem. Res. 38 (1999) 1215.
- [23] H.Xu, W.-M. Liao, H.-F. Li, Ultrason. Sonochem.14 (2007) 779.
- [24] K.P. Guzen, A.S. Guarezemini, A.T.G. Orfao, R. Cella, C.M.P. Pereira, H.A. Stefani, Tetrahedron Lett. 48 (2007) 1845. and references cited there in.
- [25] A.K. Sinha, B.P. Joshi, A. Sharma, V. Kumar, R. Acharaya, Aus.J.Chem. 60 (2007) 124.
- [26] A.K. Sinha, A. Sharma, B.P. Joshi, Tetrahedron 63 (2007) 960.
- [27] V. Kumar, A. Sharma, M. Sharma, U.K. Sharma, A.K. Sinha, Tetrahedron 63 (2007) 9718.
- [28] N.M.A. Rahman, T.S. Saleh, M.F. Mady, Ultrason. Sonochem.16 (2009) 70-74.
- [29] E.K. Goharshadi, Y. Ding, N.M. Jorabachi, P. Nancarrow, Ultrason. Sonochem.16 (2009) 120–123.
- [30] G.H. Mahdavinia, S. Rostamizadeh, A.M. Amani, Z. Emdadi Ultrason. Sonochem.16 (2009) 7 - 10.
- [31] A.C.Cole, J.L.Jensen, I.Ntai, K.L.T.Tran, K.J.Weave, D.C.Forbes, J.H.Davis Jr., J. Am. Chem. Soc. 124 (2002) 5962.

[32] A. Parmar, H. Kumar, Synth. Commun. 37 (2007) 2321-29.

[33] S. Puri, B. Kaur, A. Parmar, H. Kumar, Hetero. Commun. 15 (2009) Article in press.

---

---

## **Multi Purpose Teaching Aid**

P. Pati

Govt. Girls' High School, Boudh, At/po/Dist-  
Boudh, Orissa, INDIA

### **Innovating teaching aids**

The word innovation, according to Oxford Dictionary, means the introduction of novelties, the alteration of what is established a novel practice and a change in established methods. Generally, in the field of education to innovate is to create something new which markedly deviates from traditional practices which have been followed since a long time to impart education at different levels. For the innovating teaching purpose a simple low cost model can be used for the better understanding of students in the fields of Science.

### **Multi-purpose teaching aid**

It is one of the Innovating teaching aids which can be used in any primary & secondary class room situation. Students can be able to use it without any difficulty to understand certain principles of physical science easily.

### **Requirements for the construction of this aid**

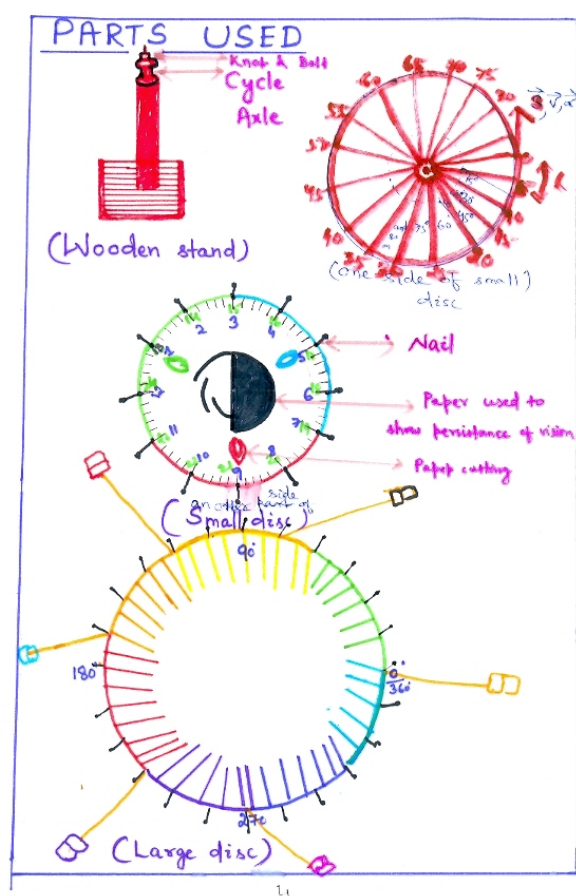
- i. Two ply wood disc 16cm radius & 8cm radius respectively
- ii. Wooden stand
- iii. Cycle axle.

### **Construction of device**

Cycle axle should be fitted to the wooden stand. A round shape drawing sheet having 16 cm radius is to be attached by gum in a ply wood disc of same size. Twenty four nails to be fixed in the disc. In the circumference the difference between two nails 2.5cm. The disc is to be attached to the axle. Another two round drawing sheet having 8 cm radius is to be attached to both side of the ply wood disc of same size. The drawing sheet of one side should be divided into three parts, Red-Blue-Green coloured papers is to be used respectively. To demonstrate colour mixing, white colour will be produced after

combination of these three primary colours. In this side twelve nails to be attached to make it

Convenient for moving freely with the help of any thread. In another side paper strips of 6cm. length and 1.5cm breadth are compactly used. Two knots to be attached below and above the large disc to the axle. In the large disc and small disc nails to be coloured. It should be noted that I discs can be easily removed and attached to the axle. One knot should be used to make it tight when it is fitted to the device. From large disc six woollen threads should be hanged from every nails, to tie the origami projects.



### Application

Teaching of many principles related to Physical science, Craft can be fruitful by using this simple device in various situations.

### Application in physical science

1. Newton's disc experiment can be easily demonstrated by using this device. White colour is the combination of seven colours out of which

Red, Blue and Green are primary colours, these three colours used in the same proportion create white colour. This experimentation can be done with the help of this disc.

2. By using origami items hanging from threads, Principle and working of centripetal force and centrifugal force can be easily explained.

3. By moving freely the nails appear to vanish due to colour combination. So the principle of illusion can be easily explained.

### Example of Accelerated Motion

If a particle moving in a circle with uniform speed, the direction of particle in each position changes with respect to time in other words the velocity of a particle moving in uniform circular motion changes which can be referred as accelerated motion. So this is an example of uniform accelerated motion.

### Linear displacement and angular momentum

Linear displacement, angular momentum, even linear velocity can be calculated easily.

$L$ =linear displacement,  $\theta$ =angular displacement,  $\omega$ =angular velocity,  $r$ =radius

$$\omega = \theta / t, \theta = l/r, w = l/rt, \omega = l/t \times l/r, \omega = v/r$$

$$\Rightarrow v = r \omega$$

$$v = \text{Linear velocity} = \text{radius} \times \text{angular velocity}$$

### Action of couple

When a force is applied tangentially to a body it produces a turning effect about the point of suspension. When two equal and opposite forces having different lines of action is applied to a body, it tends to rotate the body. For example, when the small disc is rotated by winding a string over it, by pulling and releasing it, then a couple acts on it due to which the body rotates.

### Craft

This device can be used to make various designed woollen covers for filer, telephone, designed flowers etc. So, Learning and earning can be simultaneously done by using this device.

## Joyful doll

During leisure it can be used as a joyful doll and six participants can get pleasure by scoring points from 1 to 6 while coming to rest after free moving with the help of threads and origami projects used in the large disc. While free moving, it produces wind current. So, it can be used as a hand fan also.

## Conclusion

So, it is one of the low cost teaching aid having so many advantages and helpful to explain various principles of physical science in the class room.

---

---

## Inter-relations Robot – Renewable Energies: A Science/Technology/Society/Environment Methodological Educational Approach

S. Oliveira e Sá<sup>1</sup>, M.A. Pereira dos Santos<sup>2</sup> and M.F.M. Costa<sup>3</sup>

<sup>1</sup>Escola EB 2,3 Alberto Sampaio,  
PORTUGAL

<sup>2</sup> Departamento de Física, Universidade de Évora, Largo dos Colegiais, 2,  
4700 Évora, PORTUGAL

<sup>3</sup> Departamento de Física, Universidade do Minho, Campus de Gualtar,  
4710-057 Braga, PORTUGAL  
mfcosta@fisica.uminho.pt

**Abstract.** The main goal of education is that one that considers and includes the pupil as active subject in the learning process, in remembering and in developing his one reasoning structures and even in his self-motivation [1, 2]. The teacher must have in mind two types of objectives: the ones that relate to the learning products, the contents; and the ones that aim at the processes of learning them selves, that is, the techniques and strategies that the pupils must use to understand the contents. Motivation plays, thus, a rather important role in the learning activities [3].

Science education must be sought as a way of contribution to the formation of enlightened citizens who, conscientious of the potentialities and the limits of the scientific and technological knowledge (for instance nuclear energy, nanotechnologies or global warming [4-7]), can take profit of the vast equipment (robots for instance [8-12]) that becomes part of their everyday life, as well as to have a rational and scientifically clarified intervention in the management of resources, in the preservation of the environment (for instance using and defending the use of photovoltaic solar panels for green electricity production [13]), in the improvement of the quality of life and in all decisions in our democratic societies that may involve directly or indirectly scientific or technological aspects.

The use of robots in experimental hands-on pedagogic activities allows a stronger focus and

commitment of the pupils, of all cognitive levels (seduced for the discovery but also the adventure, the challenge and the game inherently herein involved), certainly offering an unforgettable learning experience. The incorporation of this game playing like experiences renders this type of experience extremely powerful educationally [14]. Furthermore in this way science will be further approached to our students and to the society in general

## References

- [1] A. Champagne, E. Leopold and J. Anderson, Factors Influencing the Learning of Classical Mechanics, *American Journal of Physics* 48 (1980) 1074.
- [2] L. McDermott, C. Lillian, M. Rosenquist, and E. van Zee, Student Difficulties in Connecting Graphs and Physics: Examples from Kinematics, *American Journal of Physics* 55 (1987) 503.
- [3] L. Camacho, *Memórias de um Tempo Futuro - Realidade Virtual e Educação*, Hugin, Lisboa, 1996.
- [4] D. Bower, *An introduction to polymer physics* (Cambridge University Press, 2002).
- [5] P. W. Atkins, *Molecular Quantum Mechanics*, 3a Edição, Oxford University Press, New York (2001).
- [7] S. K. Mendiratta, *Introdução ao Electromagnetismo*, ed. Fundação Calouste Gulbenkian, Lisboa (1984).
- [9] R. F. Bianchi, *Estudo das propriedades electrónicas e ópticas de filmes e dispositivos poliméricos*, D. Phil. Thesis, São Carlos (2002).
- [10] C. Byrne, High School Chemistry Education and Virtual Reality, Human Interface Technology Laboratory, January 1996, [http://www.hitl.washington.edu/projects/learning\\_center/publications.html](http://www.hitl.washington.edu/projects/learning_center/publications.html).
- [11] H. Moravec, *Homens e Robots - O futuro da inteligência humana e robótica*, Gradiva, coleção Ciência Aberta, n.o 57, Lisboa, 1992.
- [12] H. Rose, *Assessing Learning in VR: Towards Developing a Paradigm Virtual Reality Roving Vehicles (VRRV) Project*: Human Interface Technology Laboratory, Report N&ordm; TR-95-1, February 1995.
- [13] SCIENCE SPACE PROJECT, The Potential Importance of Virtual Reality Technology for Science Instruction, July 1994, <http://www.jsc.nasa.gov/cssb/vr/ScienceSpace/>.
- [14] W. Winn, A Conceptual Basis for Educational Application of Virtual Reality, Human Interface Technology Laboratory, January 1996, [http://www.hitl.washington.edu/projects/learning\\_center/publications.html](http://www.hitl.washington.edu/projects/learning_center/publications.html)
- [15] J. Pople, D. Beveridge, *Approximate Molecular Orbital Theory*, ed. McGraw-Hill Book Company, New York, (1970).
- [17] P. Yam, *Surreal Science - virtual reality finds a place in the classroom*, *Scientific American* 268 (1993) 103.
- 
-

## Knowledge As A Service (KaaS) by Using A Modern Knowledge Based System Through Reusable Components

T. Shah  
VNSGU, Surat, INDIA  
proftejas@gmail.com

**Abstract.** Knowledge plays a vital role in every stage of communication, learning and research. As the era will come when knowledge will be provided as one service, which is of regular usage. Constructing a modern knowledge based system is a challenging task and requires a lot of effort for development of knowledge database and extracting relevant knowledge when required from that. In this paper I have analyzed the new vision of knowledge empowerment by using the reusable components.

This paper analyze the requirements of providing knowledge as a service directly utilized by the end user which can be the students and constructing such kind of system with the extension of available knowledge base system by utilizing the different components. Such system requires the fundamental of pay as per the knowledge you are using. Students will be directly benefited from this system in education.

**Keywords:** Knowledge As A Service (KaaS), knowledge based system, end user, reusable components

### I. Introduction

The use of latest knowledge based system helps in many areas of teaching. The students, teachers, researchers are taking the advantage of already developed and existing system which are developed with the help of expert system. The knowledge extraction and collaboration from the existing system will benefit a lot with cost effectiveness. The cloud-computing era is trying to provide the users everything as a service. As the service-oriented architecture is producing meaningful information with the integration of all the services, we can consider the knowledge as a service to be used only when required.

This paper explains the provision of knowledge as integrated service from the modern

knowledge based system. The other facets are focusing on the aspects of using the components, which are already available. If the new system requirement is coming which produces the knowledge, to develop such kind of system will require lot of efforts and that is also the challenging task. Instead of that by using the components to existing knowledge-based system, we can create the environment of modern knowledge based system, which helps the students to experiment with hands-on science. The mass of students, teachers, and researchers can only required to pay whatever knowledge they are using from this system.

Software reuse is one of the most important areas of interest in computer science as it may improve the productivity and quality of software development. Since the consideration of this activity as an engineering process, different proposals about reuse have been made following different models. As new programming paradigms for application development were proposed (e.g., structured programming, functional programming, object-oriented programming, etc.) new approaches for reuse were also considered, giving rise to interesting contributions that have reduced considerably the effort required for building new applications. In particular, the scenario provided by internet has promoted the interest in this approach because it provides a virtual platform with searching facilities that significantly increases the number of potential users of available reusable components. [1]

It is very difficult to create the expert system, which produces the knowledge, so by using the reusable components it is possible to construct the new system. The efforts are going to be saved as such system will require infrastructure, components construction and other software utility.

With the use of Knowledge As A Service (KaaS) paradigm one can be benefited from reusability and sharing of the data. E.g. The students working on the live practical of protein calculation among species, with such kind of knowledge based system, he can be benefited from getting analysis of protein class as the service provided to him.

Another advantage is to reuse the knowledge, which is coming from the collection of components.

## II. Knowledge as a service (kaas) paradigm

The application usage of the knowledge based system placed on the cloud, so everyone can access it and users need to pay only for what they are using.

The Knowledge As A Service Paradigm will include following components with respect to the student who will be using the knowledge to perform the practical on various subjects.

### A. Software as a service (SaaS)

A SaaS application runs entirely in the cloud (that is, on servers at an Internet-accessible service provider). The on-premises client is typically a browser or some other simple client. The most well-known example of a SaaS application today is probably Salesforce.com, but many, many others are also available.

### B. Attached services

Every on-premises application provides useful functions on its own. An application can sometimes enhance these by accessing application-specific services provided in the cloud. Because these services are usable only by this particular application, they can be thought of as attached to it. One popular consumer example of this is Apple's iTunes: The desktop application is useful for playing music and more, while an attached service allows buying new audio and video content. Microsoft's Exchange Hosted Services provides an enterprise example, adding cloud-based spam filtering, archiving, and other services to an on-premises Exchange server. [2]

### C. Knowledge As A Service (KaaS)

A KaaS application runs to extract the knowledge from the modern knowledge based expert system and provides these directly to the end user. Every processing on data and information is done on the system side and after extraction one will get the knowledge as the end user service. With respect to this paper, student will get the immediate help on the experiment he is performing by collecting knowledge from system which converts the information into semantic format that student can understand.

## D. Cloud platforms

A cloud platform provides cloud-based services for creating applications. Rather than building their own custom foundation, for example, the creators of a new SaaS application could instead build on a cloud platform. As Figure 1 shows, the direct users of a cloud platform are developers, not end users. Understanding cloud platforms requires some agreement on what the word "platform" means in this context. One broad way to think about it is to view a platform as any software that provides developer accessible services for creating applications. The next section looks at this idea in a bit more detail. [3]

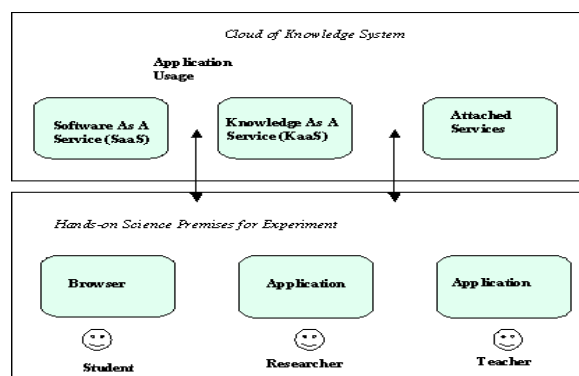


Fig. 1 The paradigm of Knowledge As A Service

The Fig. 1 indicates the architecture from where the user can get the service of knowledge if knowledge based system can be incorporated on to the cloud. As indicated in the figure, students, but researchers as well as teachers get benefited from the knowledge-based cloud and they can perform experiment on already available components.

The user can work on the premise where hands-on science technique is going on and the system is producing the knowledge. With KaaS, you can also get the benefit of SaaS and other attached services on the knowledge cloud.

Data in the cloud refers to the cloud storage idea, where data is stored somewhere on the Web through abstract APIs with loose schemas and without *any* constraint of space, availability and scalability. Clients can *completely* rely on the data cloud and count on loose coupling, as access is not tied to particular access patterns dependent on the use of specific schemas. This loose coupling is similar to the one provided by Triplespace Computing [4] [5] an emerging coordination paradigm combining semantics,

tuplespaces and Web Service technology for the persistent publication of knowledge and the coordination of services using that knowledge.

The Triplespace Computing paradigm with data in the cloud forming the “knowledge in the cloud” vision, which incorporates support for knowledge (semantic data), coordination (collaboration) and self-organization (internal optimisation). [6]

Students can save the semantic of the different experiments in the cloud database. When extraction is going on from the system side, the user can get the knowledge, which required.

### III. A modern knowledge based system

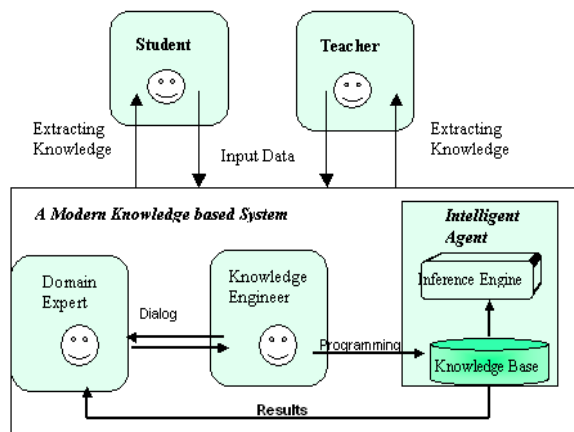


Fig.2 A Modern Knowledge based System

As indicated in the Fig. 2 Students can interact with knowledge bases system which is comprising of Domain expert, Knowledge engineer and intelligent agent. The intelligent agent will interact with the inference engine, which extracts and stores data in the knowledge base.

Teachers and researchers can access knowledge to teach the students directly from the knowledge based system.

As and when required, if there is any addition to knowledge students and teachers both can input more data for the required domain. After extracting the knowledge from the knowledge-based system, it should be applied to the experiments where it is required.

### IV. Issues and challenges

The KaaS paradigm is going on the basis of pay for what knowledge service you are getting

from the system. But here the main challenge is to have the interaction between the practical experiment that student is performing and extracting knowledge from the modern system.

The other challenge is to take payments from the students. Generally this system is going to be implemented either in school or college, so how to get payment for the usage of knowledge. We can provide knowledge from the system and can take the charges as semester fees or we can take token fees from the students for collecting payment.

### V. Conclusion

As the teaching world is drastically changes, it requires such kind of system, which generates the knowledge and collaborated throughout the organization. The Knowledge As A Service (KaaS) paradigm specified here will take care about producing the knowledge, which is useful to the end users. Reusable components will create a system that requires less effort, as it can happen to develop a new system starting from the scratch. Hence this paper generates immense knowledge to perform any kind of experiments while learning for students as well as to teachers.

### References

- [1] Martin Molina, Jose L. Sierra, Jose Cuenca “Reusable Knowledge-based Components for Building Software Applications: A Knowledge Modelling Approach” International Journal of Software Engineering and Knowledge Engineering Vol. 9 No. 3 (1999) 297-317.
- [2] David chappell august 2008 “Short introduction to cloud platforms an enterprise- oriented view”
- [3] David chappell august 2008 “Short introduction to cloud platforms an enterprise- oriented view”
- [4] Fensel, D: “Triple-Space Computing: Semantic Web Services Based on Persistent Publication of Information.” In: IFIP Int’l. Conf. on Intelligence in Communication Systems, pp. 43–53 (2004)
- [5] Simperl, E., Krummenacher, R., Nixon, L.: “A Coordination Model for Triplespace Computing”. In: 9th Int’l. Conference on Coordination Models and Languages, pp. 1–18 (2007)



- [6] R. Meersman, Z. Tari, and P. Herrero  
“Towards Knowledge in the Cloud” OTM  
2008 Workshops, LNCS 5333, pp. 986–995,  
2008. c\_Springer-Verlag Berlin Heidelberg  
2008.
- 
- 

## Wireless embedded control system for home automation

H.J. Lad and A. S. Chaudhari  
Gujarat Univ., Udhana-Magdalla Road,  
Surat, INDIA

*hiteshlad.msc@gmail.com,*  
*shailesh\_mca@yahoo.com*

**Abstract.** Advance technology developments in home real-world management automation system make more comfortable safe home. To automatic management system continuously measure different home environment parameters like temperature, light intensity, water level surround the home. On the bases of measurements system intelligent devices take as early as corrective controlling steps to control the situation requirements. Features of Wireless embedded control system like flexibility, modularity, s/w modifications without changes in hardware, economical, etc.. are most suitable for home automation system. Environment parameters measured by the sensor devices and collect the information which access by control system at regular schedule and send control Ir(Infrared)-command signals to the automation control system. Scheduling of events can be handled by firmware program which is inbuilt in the embedded system. Wireless system provides faster and efficient communication between the sensor device and control system.

### 1. Introduction

Embedded control system within home automation system provide so many sophisticated features like more self-controlled mechanism and automated scheduled intelligent device which fulfill human-being daily basic requirements[2]. Its utilize recourses very efficiently by reducing wastage of resources like water, electricity, etc... Real-world sensor measuring the different parameters at regular time intervals and fed measured data in to the

system. On the basis of Input data run the user-defined program on a special-purpose processor (microcontroller) and system takes the self decision to send particular command for the particular control unit. Embedded system designs to be flexible and reprogrammable, extensible, modular and forward-compatible, so that new components can be added without redesigning the entire system.

## 2. Proposed model:

In the proposed model sensor is sense physical environmental parameter and convert in to electrical analog signal which sends to monitor feedback and control unit(MFC). MFC translate analog signal in to digital signal by the help of analog to digital convertor (ADC). Digital signal values compare with preloaded values range related to particular parameter. In case if the measured data do not match with preloaded value range the control system take the immediate primary actions like trigger the particular appliance to maintain the stable condition and also send information to Base Control System(BCS). BCS keep record of the secondary control system events, send command to preventive action control system for the advance level controlling actions to maintain the situation requirements. Feedback System continuous scans sensor measured data at regular interval and interpret the information. System decision more deepened on the interpreted information and according to the interpretation System can generates controlling command to perform various actions on the particular appliance.

Home appliance actions handling can be possible by manually from the remote location. User Remote control device (URC) can communicate directly with home appliance and control various actions of the appliances. If URC can not communicate directly with the appliance at that time URC send information to Base control system, BCS handle the Home appliance or take

appropriate preventive action via preventive action control system.

self decision control systems do value addition in smart home. Control system takes self decision on the basis of sensor sensed physical parameter and change current status of particular home appliance like intensity of light goes down in a garden compare to predefine light intensity value garden lamps/tube lights become ON. Administrator display/interface unit control various parameter sequential display, configure and control unit give permission to system administrator to change measurement parameter critical value range in the system and also provide the complete record of critical events and give the track of prevent /protection actions.

Smart home also require security against Natural disaster by measuring environmental parameters. System finds the degree of possible damage due to the disaster can be calculated by calculating the difference between the standard built in data and the data received from various sensors. If the harmfulness of the disaster found to be very high then the system warns for the intensive actions. The moment control system finds some abnormalities then the base control system ask control system to monitor and display the situation more sharply to monitor the rate of the growth of the damaging power of the disaster. Display and control unit provides checking facility for user and after checking condition if user is not find any abnormal condition then user can reset the alarm. Automatic.

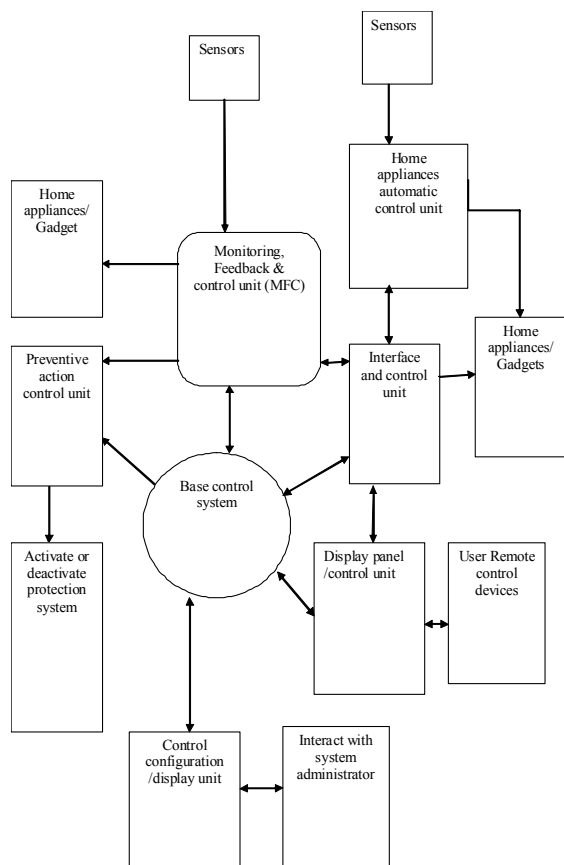


Fig. 1 . Proposed home automation system model

Control devices can communicate with each other via physical media or a wireless media like RF-radio, wi-fi, Bluetooth, Infrared (IR). Wireless communication is more suitable for automation purpose. IR wireless communication system is commonly prefer in Home automation.

### 3. Working of remote control module

RC-5 protocol provides communication between two controls systems. The user remote control system also uses to send command from remote control to control unit. We developed one wireless IR-remote control based home appliances control module to provide various appliances on/off facility, fan speed selection facility within room.

### RC-5 PROTOCOL [1],[2][3] [4], [5], [6],[7].;

Start bit 2-bit	Control bit 1-bit	Address 5-bit	Command 6-bit
-----------------	-------------------	---------------	---------------

Fig 2. RC-5 Protocol bit pattern

The start bits are always logic '1' and intended to calibrate the optical receiver automatic gain control loop. Next, is the control bit. This bit is inverted each time the user releases the remote button and is intended to differentiate situations when the user continues to hold the same button or presses it again.

The next 5 bits are the address bits and select the destination device. A number of devices can use RC5 at the same time. To exclude possible interference, each must use a different address. The 6 command bits describe the actual command. As a result, a RC5 transmitter can send the 2048 unique commands. The electrical signals convert in to optical signals by the optical transmitter which transmitted optical signals toward receiver. The receiver performs the reverse function. The photo detector converts optical transmission into electric signals, the receiver output bit stream can be used to decode the RC5 data word. This operation is done by the microprocessor typically, please note that the receiver output is inverted.

When the user pushes a button on the hand-held remote, the device is activated and sends modulated infrared light to transmit the command. The remote separates command data into packets. Each data packet consists of a 14-bit data word, which is repeated if the user continues to push the remote button.

In the RC-5 protocol 5- address bits are use for addressing room or address particular special portion of the home like garden, porch, etc... means for room no-1 address is 00001 for kitchen address is 00010 for main door address is 00011. Next 6- command bits are allocate different command to particular condition/parameter or command for particular appliance on/off information,

means tubelight-1 ON information command is 000001, command to generate smoke alarm by giving command 000010 to alarm circuit, if temperature goes beyond the preset temperature value high temperature detection command is 000011, to ON air-conditioner 000100, etc... If system find some abnormal condition in temperature at kitchen then by combining start bit-11 control-1/0 bit address bits-00010 and command bits-000011 control system transmit complete informative command-11000010000011 to base control system. Base control system decodes the command and recognizes the room location and condition abnormality type. On the bases of decoded information base control system takes preventive actions like it make ON air conditioner in the kitchen by sending command 11000010000100 to secondary control system. Secondary control system make on air-conditioner and try to maintain temperature range in the kitchen its also use in some security systems like fire preventive systems. In fire control system first detect smoke in room no-3 and fire control system send alarm command 11000011 000010 to the base control system. Smoke command information is decode by base control system and on the bases of the decoded information base control system send command 11000011000100 to fire control system to start water shavers system in the room No-3, unlocked/open doors and open the ventilators of the room number, this protocol also use to control some appliances from remotely like by using remote control, person can make room lights on/off, change fan speed, open/close garage Sutter, etc...

#### 4. Conclusion

The System is designed, modeled and simulated on computer. The result of simulation indicates the perfect functionality of the system. Modular construction based Emulator of the system provide new feature and additional facilities embedded in the

system which will be more user friendly and economic.

#### 5. References

- [1] Zoran Polic:” *Comparison of Commercial Infrared Data Coding Schemes*”, IEEE Transaction on communications, Manuscript ID.
  - [2] Javier Castro and James Psota:” *The Specification, Design, and Implementation of a Home Automation System*” 6.111: introductory [2]Digital Systems Laboratory Final Project page no:6-9Massachusetts Institute of Technology.
  - [3] Buccini / Stefan Schauer: ”*Decode TV IR Remote Control Signals Using Timer\_A3*”, Mark Application Report SLAA134 - September 2001, texas instruments.
  - [4] Victor Kremin:” *RC5 Codec*”, AN2091, Cypress Microsystems, Inc.
  - [5] Stanislav Arendarik , Roznov, Czech: ”*implementing the Infrared RC-5 Decoder on MC9RS08KA2*” : Republic Document Number: AN3402, Rev. 0, 04/2007, freescale semiconductor.
  - [6] San Bergman, “*SB-Projects [Online]*”. Retrieved October 4, 2003. Available: <http://www.xs4all.nl/~sbp/index.htm>.
  - [7] “*IR-remote control NEC protocol* ”, <http://www.sbprojects.com/>.
- 
-

## Pedagogical Material that Promotes Students Interest in Science

S. Carreira-Leal<sup>1,2</sup> and J.P. Leal<sup>1,3</sup>

<sup>1</sup>Departamento de Química e Bioquímica,  
FCUL, 1749-016 Lisboa, PORTUGAL

<sup>2</sup>Escola Secundária de Albufeira,  
PORTUGAL

<sup>3</sup>Unidade de Ciências Químicas e  
Radiofarmacêuticas, ITN, 2686-953

Sacavém, PORTUGAL

sergioleal20@gmail.com, jpleal@itn.pt

**Abstract.** Nowadays students show lack of motivation when learning science, for instance Physics and Chemistry, which is accentuated through their academic path. This fact is obvious when we see children asking a lot of questions in the first years of age which disappear in time. The situation mentioned above suggests, among other factors, a classic approach and a missing contextualization of the scientific concepts. The present academic approach prompts to that e-learning will become a normal part of the practice over time, complementing traditional methods and that students will expect e-tools and experimental work to be available to enhance and support their learning

**Keywords:** innovation, technology, science, teaching/learning, motivation, e-lab.

### Introduction

A study made at 2006 [1] suggests that experimental work and new technologies are valuable resources to increase motivation of students in science learning. A virtual laboratory, called e-lab, has these two valences: remotely (at home or at school) is possible to execute several experiments. E-lab has real experiments in a virtual environment. The intention is studying several resources to improve the science teaching/learning at schools. The goal of this virtual laboratory is give access to teachers and their students to a laboratory where is

possible to collect data at real time, increasing this way the traditional methods of analytic and numerical studies. This laboratory has also the possibility to perform experiments that need expensive material, or perform experiments without the concern about safety precautions. The Ministry of Education in Portugal intends to contribute to the increase of scientific literacy of students, assuming that the learning process should have different velocities. Furthermore, schools and teachers have to organize/adapt the curriculum of each scientific area, according to students they have at school [2]. A study from Berkeley University [3] supports an approach on Science, Technology, Society and Environment that will contribute to the increase of students' scientific literacy. Other source [4] says that students need to participate in their process of learning, which improves positive results. Only students that understand the importance Physics and Chemistry have in our lives are interested in studying science. The pedagogical practice needs to valorise activities that promote students' scientific knowledge and diversified ways of intervention/participation of students in classrooms, creating discussion opportunities inside classes. These pedagogical practices also need to promote the use of new technologies and experimental work in classrooms [5,6,7,8]. E-lab is a platform to science teaching that intend to develop scientific knowledge and motivation on students.

### Objectives

Physics and Chemistry in Portugal are frequently rejected by students because of the referred difficulty of their curricula [4]. However, Physics and Chemistry are important subjects to the construction of students' scientific literacy knowledge and to their academic path in our technological society. The essential objective of this study is to propose ways to invert this process, giving several and diversified proposals to

increase students' interest and motivation in scientific areas such as Physics and Chemistry. To achieve such goal two channels are essentially used: new technologies and experimental work. To implement that, it is important to have virtual laboratories like this to help teachers to perform some experiments that are impossible to do at school either because lack of material or by safety precautions, for example.

### **Description**

Physics and Chemistry teachers face many challenges all over the world. In many countries there is an interest in the number of students who choose Physics or Chemistry as a study subject beyond the point where it becomes an option in the school system. Students' comments on their experience of school science suggest that only a minority finds Physics or Chemistry curricula subjects of great interest. Many of them fail to see the relevance of these to their lives and concerns. Another and different challenge is the quality of teaching and learning. Teachers and educators are becoming increasingly aware that many students fail to grasp some very fundamental scientific ideas, even after many years of study. So we cannot be entirely satisfied with what we are achieving even with those who choose to study the above areas. It's important that school science became more attractive and useful to a higher percentage of school population, and that Physics and Chemistry have a high contribution on this. A study made in 2006 by one of us [1] suggests ways in which we might improve the effectiveness of our teaching of fundamental Physics and Chemistry ideas and more generally, the interface between research and practice. Is fundamental change teachers' orientation about the methods for teaching/learning science? Teachers, have to consider what responsibility they have or what are the reason or reasons to the low motivation in scientific subjects such as Physics and

Chemistry. How to motivate students? It is useful to develop collaboration strategies and share knowledge. For example, teachers can: (i) plan problematic situations with interest for the students; (ii) try to solve with students real problems; (iii) show positive expectations in the evolution of learning science. Probably the best answer to increase students' scientific knowledge is expanding the use of new technologies and experimental work in teaching methods [1]. But, in this process, teachers must have a word and be the guides of students' learning. Besides, is important teachers' initial and continuous formation keep up-to-date about new methods of learning/teaching science [9]. Here the interaction school-university is mandatory. This study discusses pedagogical challenges with regard to insert individual flexibility, collective tools and resources in order to increase the interest and motivation to the study of science. In particular, we show the potentiality of a scientific virtual laboratory that can be used any time, anywhere. This e-lab has contents for students and for teachers, and has at this time six working experiments and more than ten are almost ready to use. The six experiments are about gravity; change pressure with volume; speed of sound; change pressure with depth; launching data; and light refraction. One important reason for changing teaching/learning methods is the growing information that is fundamental for students, teachers, and the whole school community. The new curricula in Portugal recommend the need to prepare intervenient and conscious individuals in the future society, a process that begins with teachers and students discussing real problems. The investigation in didactics is always concerned about the quality of scientific education for everyone. Teachers are active agents in the action of the investigation with the implementation of the curricula at school. Nowadays the main objective of educating is forming and preparing the young people for the future, giving them the tools they need to construct their future at

professional, social and economic level. In this process new technologies have an important role. New technologies offer a great opportunity but also great challenges to teaching/learning of scientific areas. New technologies give opportunities for the creation of learning environments in an easy way than traditional methods. They can facilitate to bring real world problems into the classroom, and therefore makes the curricula more interesting for students and teachers. These kinds of resources provide tools to improve the quality of today's education. New information technologies cause a revolution in the present society. In fact, the potentialities that propitiate of these resources are crucial in today education. The observation and interpretation of natural phenomena are central goals to increase individuals' scientific literacy. In Portugal scientific education needs to enlarge the proximity between the abstract theory and the observable phenomena. Students often learn subjects by rote. They follow the prepared assignments, and are bound to handouts, textbooks, and worksheets in order to perform successfully on examinations. When faced with a situation that does not provide needed information, students become blocked with no alternative skills for acquiring new information on their own. The research in new pedagogical activities with increased scientific quality is the objective of this project. The e-lab is one of the concepts that we are working on. Problem-based learning with experimental work and new technologies places students in contextual learning situations, creating an education of meaning rather than an education of fact collecting. Students are given a real role in the problem which increases the meaning of that learning. They will readily understand why they need to have access to the concepts and how they are expected to apply them. In a preliminary study we start working with the e-lab (Fig. 1 and Fig.2) resource, which uses online virtual laboratories. The main advantage of an online virtual laboratory is the usage by schools that don't have other

possibilities to achieve material for developing experimental work with students. Till now, students' interest to learn using e-lab is clearly strong. Next step will be the production of pedagogical materials using new technologies of communication and information as virtual learning environments, e-learning projects and experiences, computer software education, videos for learning, digital libraries or repositories, and e-portfolios in order to increase students motivation and interest in science, relating the scientific knowledge with everyday life since primary school. Figure 1. Picture 1 of e-lab. Figure 2. Picture 2 of e-lab. Learning about natural phenomena in everyday life (Physics) and the materials characteristics and transformation (Chemistry) around us are interesting subject matters. According to students [1,4,6] this areas are difficult, they need engagement and the obtained marks are not as high as in other areas, so they choose to study different subjects. It is urgent and necessary to change students' mentality about science, and bring more people to these areas of knowledge.

### Conclusion

Teaching nowadays is, as always, a challenge. In order to keep students motivated and worried about scientific questions that appear all the time, in everyday situation, teachers need to change pedagogical methods in classrooms. The use of new technologies and experimental work seems to be a positive option to make students active in their process of studying science, like Physics and Chemistry. It is also important that teachers are motivated and participant in a continuous training [9] to implement virtual laboratories, virtual learning environments, e-learning projects and experiences, computer software education, videos for learning, digital libraries or repositories, and e-portfolios in order to increase students motivation and interest in science, connecting the scientific knowledge with the everyday life as soon as

in primary school in order to get the best results. We must never forget that new technologies and experimental work are only fantastic resources when well guided by teachers, to increase the interest in science, and they should never be considered as a rescue strategy to motivate students. The new technologies approach must be introduced increasingly in the teaching/learning process along the academic curricula. Starting with almost nothing, calculating without calculators and practicing mental and scientific concepts, and then increase the use of new technological resources to maintain the interest and motivation in scientific areas like Physics and Chemistry.

### Acknowledgements

S. C. Leal want to thanks the Portuguese Foundation for Science and Technology a PhD grant (SFRH/BD/44889/2008), the travel grant from Hands on Science organization and Instituto Superior Técnico, the Portuguese University Institute that lodge the e-lab platform.

### References

- [1] Leal, S. C. A química orgânica no ensino secundário: percepções e propostas. MsC. Thesis. Aveiro: Universidade de Aveiro; 2006.
- [2] Ministério da Educação, Departamento do Ensino Básico. Programa de ciências físicas e naturais: Orientações curriculares para o 3.º ciclo. Lisboa: Autor; 2001.
- [3] SEPUP. Science Education for Public Understanding Program; 2008. <http://www.lhs.berkeley.edu/SEPUP> [21/08/2008]
- [4] Paiva, J. O fascínio de ser professor. Lisboa: Texto Editores; 2007.
- [5] Leite, L. Contributos para uma utilização mais fundamentada do trabalho laboratorial no ensino das ciências. In Departamento do Ensino Secundário

(Ed.), *Cadernos Didáticos das Ciências*. Lisboa: Ministério da Educação, Departamento do Ensino Secundário; p. 78-97; 2001.

- [6] Martins, A., Malaquias, I., Martins, D. R., Campos, A. C., Lopes, J. M., Fiúza, E. M., da Silva, M. M. F., Neves, M., & Soares, R. Livro branco da física e da química (1.ª ed.). Aveiro: Minerva Central; 2002.
  - [7] Martins, I. P., Simões, M. O., Simões, T. S., Lopes, J. M., Costa, J. A., & Claro, P. R. Educação em química e ensino de química: Perspectivas curriculares. *Boletim da Sociedade Portuguesa de Química*; 95: 42-45, 2004.
  - [8] Martins, I. P., Simões, M. O., Simões, T. S., Lopes, J. M., Costa, J. A., & Claro, P. R. Educação em química e ensino de química: Perspectivas curriculares – Parte II. *Boletim da Sociedade Portuguesa de Química*; 96: 33-37, 2005.
  - [9] Marques, M. Formação contínua de professores de ciências: Um contributo para uma melhor planificação e desenvolvimento. Porto: ASA Editores; 2004.
- 
-



## Astronomy with an 8-Inch

R.K. Bhattacharyya

Department of Applied Mathematics  
Calcutta University Calcutta 700009, INDIA  
rabindrakb@yahoo.com

**Abstract.** An 8-inch reflecting telescope should be the pivotal equipment in amateur astronomy. An 8-inch reflecting astronomical telescope with heavy duty equatorial mounting brings before the eyes of the observer the magnified and distinct images of the moon, the planets in details, their satellites, nebulae and stars; binaries can be distinguished, star clusters are visible; the red, orange, greenish and bluish colours of celestial objects are discernible. The lunar surface topography, ridges and rills, and the sunspots and faculae can be studied rigorously through an 8-inch. The fascinating worlds of nebulae can be sighted and identified with clarity. The exciting, immense and as-if-living and overwhelming experiences of amateur observers and graduate or undergraduate learners with an 8-inch are depicted below. The discussion is carried out from the standpoint of astronomy education in India in particular and for developing countries in general.

**Keywords:** Halley, amateur, astronomy, education.

### Indian culture and heritage in astronomy, astrophysics and mathematics

In India, even today, not more than a microscopic few belonging to the small educated community, not to speak of the illiterate masses, have ever peeped through the telescope to look into the sky. The vast spectacular universe which unfolds itself before the eyes when viewed through the telescope remains entirely un-introduced to them for ever. (Is it because of this inability to look beyond the earth that we more often than not get bogged down with trivial earthly

problems?). But astronomy is not a subject foreign to this country. Ancient Indian astronomers accumulated great knowledge while Europe remained dormant during the period (500-1100 AD). H.T.Colebrooke's translation of Brahmagupta's *Brahmasphutasiddhanta* (628 AD) gives a chronology of ancient Indian astronomers [1]: Varahamihira (200 AD), another Varahamihira (505 AD), Brahmagupta (598 AD), Munjala (933 AD), Bhattotpala, Swetotpala (1017), Varuna-Bhatta (1040), Bhoja-Raja (1150 AD), Calyan-Chandra (1179). Not long ago, possibly holding high the banner of Indian tradition in Astronomy, Radhagobinda Chandra (1878-1975), a village astronomer, an amateur astronomer at that, of Bengal, made original contributions to knowledge on variable stars by peeping through a 3-inch telescope purchased from his humble earnings [2]. Rabindranath Tagore, the poet, and described as "the child of the Upanishads", wrote a book on astronomy titled *Viswaparichay* (Introduction to the Universe), comprising chapters on "World of Atoms", "World of Stars", "Solar System", "Planets" and "Earth". In writing this book did Tagore not carry with him the ancient Indian tradition and culture in astronomy ([3]-[5])?

### Astronomy and astrophysics teaching in modern Indian education system

However, in modern times, astronomy is taught in undergraduate colleges as part of mathematics or physics courses. There are not many university faculties in astronomy or astrophysics in the country. Punjabi University can boast of having a Department of Astronomy and Space Sciences comprising a 20-inch reflector telescope mounted on a dome at the campus at Patiala. In 1983-84 only two students were awarded doctorate degree in astronomy in the country [6], in Osmania University. Calcutta University had the tradition of teaching Astronomy from pass degree course to M.Sc. level. Now astronomy has been dropped

from B.Sc. Pass course and the course content has been reduced in B.Sc. (Honours) mathematics from 50 to 30 marks only. The University Grants Commission [7] provided 3-inch telescopes to 452 university departments in physics and mathematics and some selected colleges out of 6912 colleges, to observe Comet Halley in 1985-86. All these do not speak highly of the status of astronomy and astronomy in the university system of education. The establishment of IUCAA, the Inter-University Centre for Astronomy and Astrophysics at Pune is, however, a giant leap forward in reviving interest in astronomy and astrophysics in the country. Nevertheless the attempt should start at the grass-roots level, in schools, through colleges and universities and through encouraging amateur astronomy activities.

#### **Amateur astronomy and international Halley watch amateur observers' manual**

However, some men not unaccustomed to sciences may question if anything worthwhile is really attainable by amateur observers these days of radio astronomy ('in 30 years, radio astronomy has not only caught up with its elder cousin, optical astronomy, but has overtaken it in some fields') [8] and Ulysses [9] and other gigantic space missions. In answer, it can be asserted that amateur activities may create and sustain interest in astronomy effectively in the society at large. Amateur observation always attracts people of all ages, students, teachers and people of all walks of life. Amateur astronomy has a great role to play on the research plane, in collecting data and in making specific observational investigations of various types. It would be appropriate to quote from the International Halley Watch Amateur Observers' Manual for Scientific Comet Studies [10]: "From the very beginning, organizers of the IHW recognized that amateur astronomers could make valuable contributions supplementing the comprehensive professional observations

being planned. Because of the large number of amateurs, the interference of weather with observations would be minimized and geographic longitude coverage would be more complete than for the smaller number of professionals participating. Also, amateurs are not constrained by telescope time allotments or other duties which might limit a professional astronomer's time. Finally, there are some observations of Halley's Comet and related phenomena which are simply more easily done by amateurs and more comprehensive coverage is possible with their help." A total of 870 amateur astronomers submitted observations on astrometry, Meteor Counts, Drawings, Magnitudes (visual appearance), Photographs and Spectra of Comet Halley during January 1985 to February 1988 [11]. The data have been analyzed and sent to specialists and to IHW Archives for storage. This clearly indicates the importance of amateur observations in scientific studies in astronomy. Moreover, today's children may be taught to look beyond the planet (in more senses than literal, though!) on the eve of their lapping into the twenty-first century. Coordinated Amateur Astronomy Programme will always attract children to all people of all sections of the society. Author's own experience with an 8-inch reflecting telescope in his Department abundantly affirms this reality. Before we delve into experiences, it would be appropriate to highlight some observational methods depicted in the Manual. This Manual was published in two parts and addressed to advanced amateur astronomers, with a view to generating meaningful scientific data on COMETS. Part I describes methods of observation and observing techniques. Part II consists of Ephemeris, Maps, Star-Charts and most importantly, Models for recording various types of data such as, visual observation, photographic information, astrometric information, spectroscopic observation, visual meteor observation etc. This manual constitutes one of the most important assets for the observing amateur

astronomer. A simple observation technique is mentioned by way of illustration: The YARDSTICK CROSSBOW is a simple device used for large scale sky measurements. It is used to measure angular distances in the sky. It consists of a shaft 57 inches long and an ordinary yardstick bent slightly with a string in an arc. Inches correspond to degrees. For observation of angular distances the eye-end of the long stick should be placed in contact with observer's cheek-bone. Final calibration of the device can be made using the star separations given below: Sky Calibration Distances Star Pair: (12)-(13) Separation (in Degrees) Boo Vir 32.8 Boo Leo 35.3 Boo UMa 37.1 Boo Lyr 59.1 Lyr Cyg 23.8 Aql Lyr 34.2 Aql Cyg 38.0 Aql Sco 60.3 Ori CMa 27.1 Ori Tau 21.4 Ori Cru 26.0 Tau Aur 30.7 Cen Cru 15.6 Cen Car 58.0 Cen Eri 61.3 CMa-Sirius, Boo-Arcturus, Lyr-Vega, CMi-Procyon, Car-Canopus, Ori-Betelgeuse, Aql-Altair, Tau-Aldebaran, Sco-Antares, Vir-Spica, Cyg-Deneb, Leo-Denebola, UMa-Mizar, Aur-Capella, Eri-Achernar, Cru-Alpha Crucis, Cen-Alpha Centauri. The manual explains the need for taking dark adaptation, the difficulties posed by atmospheric transparency and sky brightness in observing Comet's tail, the size and magnitude of its coma, meteors etc.

### **Experience with an 8-inch telescope**

An 8-inch reflecting telescope should be the pivotal equipment in Amateur Astronomy. An 8-Inch Newtonian Reflecting Astronomical Telescope with heavy duty equatorial mounting (altitude 12 metres, latitude N, longitude in arc, in time, brings before the eyes of the observer the magnified and distinct images of the Moon, the planets in details, their satellites, nebulae and stars; the binaries can be distinguished, star-clusters are visible; the red, orange, greenish and bluish colours of celestial objects are discernible. The lunar surface topography, ridges and rills and the sun-spots and faculae can be studied rigorously with an 8-Inch.

The far, far away worlds of cloudy nebulae such as Orion and galaxies such as Andromeda can be sighted with clarity and excitement! Experiences with the 8-Inch Telescope unmistakably demonstrate that it is capable of exciting immense interest among the students. Some of them have already carried this interest along with them so as to take up Astronomy and Astrophysics as their career subject, some of the young amateur astronomers have thoroughly plunged themselves into amateur observational activities. For others it was found difficult to sustain their interest in Astronomy due to complete lack of photographic, photometric, spectroscopic and other modern facilities within their institutes. All these lead one to conclude that it will always be rewarding to give some more opportunity to our students, with the primary objective to stimulate their interest in the subject, to study and to observe the vastly open, excitingly splendid sky! Amateurism will lead to professionalism in research in astronomy and astrophysics in no time. This is possibly the most valuable finding resulting from an experiment with the 8-Inch Telescope installed in an undergraduate College! "Urban sky-glow is robbing us of our night skies", says the Sky and Telescope, in July 1990. It is reported that the 100-Inch telescope atop Mount Wilson in California has recently been decommissioned in part because of severe sky-glow from Los Angeles basin. It is feared that this telescope will not be able again to undertake studies on faint stars or galaxies. This clearly conforms to our experience with the 8-Inch Telescope too. The great nebula of Orion was observed with clarity and satisfaction on the night of 18 January 1980. It was a new-Moon day and the sky was completely dark under a spell of all-out electrical power-cut. This experience never returned to us. The delightful experience of discovering the far away distant worlds of great Galaxies M31 (Andromeda Galaxy: it is a spiral galaxy. Two of its close satellites are: the small

Galaxy NGC205 which is very close to the disk and the elliptical Galaxy M32 a little further away) and M33 (the Sc type galaxy in Triangulum) is already a matter of the past. It would be hard to locate the galaxies in future because of the light and dust pollution of the urban night sky. How many stars can one expect to visible through the naked eye from say Shyambazar or Gariahat in Calcutta or from the heart of Beijing in China in these nights of sky-high urban light pollution? A 3-Inch Telescope will just be useless in an urban area.

### Conclusion

Amateur astronomy excites professional research, both theoretical and observational, in astronomy and astrophysics. Some steps are therefore suggested below to popularize Amateur Astronomy. 1. District Level Astronomy Centres, equipped with reflecting and or refracting telescopes, binoculars, charts, maps, books and journals such as Sky and Telescope, European Space Agency Bulletin, Khagol etc., may be set up in some district Schools and Colleges. 2. Colleges where some infra-structural facilities already exists for carrying out astronomy activities may be selected for up-gradation that is for strengthening their resources by extending assistance in terms of equipments, part-time or full-time staff etc. In Calcutta, for example, at least three Colleges may be chosen for the purpose: St.Xavier's College (owning telescopes and telescope dome), Presidency College (owning telescopes and telescope domes) and Brahmananda Keshab Chandra College (owning an 8-Inch reflecting telescope). It is important to select some other institutes of repute located away from Calcutta. 3. An Amateur Observers' Bulletin may be published. The bulletin will publish charts, maps, ephemeris related to important impending astronomical events. It will discuss various methods such as visual, photographic, spectroscopic etc., and techniques of observing astronomical objects and phenomena viz., comets, meteors,

asteroids, the Moon, planets- their satellites and rings, eclipses, galaxies, clusters and binaries. The bulletin will publish reports of amateur observations to explore the possibility to exchange scientific-observational ideas and encourage interaction. 4. The Inter-University Centre for Astronomy and Astrophysics (I U C A A), Pune, may be urged assume the role of the pivotal amateur astronomy organization to concretize, implement and coordinate the proposals described above. 5. IUCAA may assign appropriate observation programmes to selected amateur centre referred to above. 6. District, State and National Level Amateur Astronomers' Meets may be organized regularly. 7. Prizes for meritorious observations and reporting in the Bulletin may be instituted at different levels. 8. Important publications such as the International Halley Watch Amateur Observers' Manual for Scientific Comet Studies (Jet Propulsion Laboratory, Pasadena, USA) may be translated into regional languages. This initiative is bound to develop interest in astronomy and science in general among the common people. 9. Active amateur astronomers may be invited to IUCAA and other National Centre for Astronomy for training in optical, photometric, spectroscopic and other methods of observation for short duration. 10. The encouragement in terms of assistance, invitation and assignment may be extended to active individual amateur astronomers working beyond the purview of University sector. All these efforts, in effect, will conform to IUCAA's twin objective of providing (i) a centre of excellence within the University sector and (ii) a centre for science popularization (ref: UGC Annual Report 1988-1989). All these efforts will generate greater interest and zeal for undertaking activities on astronomy and astrophysics and this in turn will encourage and promote professional research too. The European Space Agency (ESA) has undertaken a programme called "Hands-on Activities for Education" with a view to

motivating young Europeans for a future in space [15]. The famous Ulysses mission has ended in 1 July, 2008, after 17 years of remarkable success in space research. The Cassini spacecraft is still effectively orbiting the planet Saturn even after 10 years of its launch. "This historic mission's stunning discoveries and images have revolutionized our knowledge of Saturn and its moons". All these information and stimulating descriptions may be made available to our students. Reasonable programmes commensurate with our educational-social-financial environment may be launched with a view to motivating our students taking interest in the sky and space.

## References

- [1] Algebra with Arithmetic and Mensuration from the Sanscrit of Brahmagupta and Bhascara, Translated by H.T.Colebrooke, 1817.
- [2] Dhumketu (in Bengali), Radhagobinda Chandra, Puthipatra, Calcutta, 1985.
- [3] Rabindranath Tagore: A Centenary Volume 1861-1961, Sahitya Akademi, New Delhi, 1961.
- [4] Rabindra Kalpanai Bijnaner Adhikar (in Bengali), Kshudiram Das, Ananda Publishers, Calcutta, 1984.
- [5] Viswaparichay (in Bengali), Collected Works, vol. 14, Rabindranath Tagore, Government of West Bengal Publication, Calcutta, 1961.
- [6] University Development in India, Part III, University Grants Commission, New Delhi, 1988.
- [7] UGC Annual Report 1988-89, UGC, New Delhi, 1989.
- [8] The Cambridge Atlas of Astronomy, 2nd.ed., Editors: Jean Audouza & Guy Israel, Cambridge University Press, 1988.
- [9] Ulysses: A Voyage to the Unknown, ESA, NASA, ESA Bulletin, No.63, August, 1990.
- [10] Amateur Observers' Manual for Scientific Comet Studies: International Halley Watch, vols. I & II, Jet Propulsion

- Lab. Publication, Pasadena, USA, Editor: S.J.Edberg, March 1, 1983.
- [11] IHW Amateur Observers' Bulletin, Issue No. 20, USA, June 1990.
  - [12] Descriptive Astronomy, R.M.Berg & L.W.Fredrick, D.van Nostrand Company, NY, USA, 1978.
  - [13] The Macmillan Dictionary of Astronomy, Edited by Valerie Illingworth, The Macmillan Press Ltd., London, 1979.
  - [14] The Battle against Light Pollution, D.L.Crawford & T.B.Hunter, Sky & Telescope, vol.80, July 1990.
  - [15] ESA Bulletin: Space for Europe, No.135, August 2008
- 
-

## Community Science Centers and Hands on Science

A.M. Prabhakar

Advisor, Gujarat Council on Science &  
Technology, Gandhinagar (GUJARAT),  
INDIA

adv-gujcost@gujarat.gov.in

**Abstract.** Hands-on Science is a unique approach of learning and teaching science to the children and students. The due importance of practical working has been given in teaching learning process. Involvement of children in actual working practicals, making working or non working models charts or involve into making chemical changes has been given more importance for generating curiosity.

The model presented here is one such effort for involving children and public into activity based science learning and removal of superstition. Unique scheme of setting of community science centre in public private partnership has been evolved out and put in practice. Presently Eighteen science centers have been established; communicators are trained and continuously supported for carrying out-reach activities through experiments at grass root level. More than seven thousand activities have been carried out at various places in last three years. The details are given in the full length paper.

### Preamble

Science and Technology have played an important role as a tool of Socio-economic revolution hence development of science and technological capacity and its application have become an important and inherent part in the planning process.

Application of Science and Technology as a modern tool for Socio-economic revolution is very much required in the interest of all round and speedy development of the state. The state has undertaken various efforts through five year plan for equal, multilateral and speedy development by using latest technology in the fields of Agriculture and its dependent industry, Engineering industry, Transportation & Communicators, Irrigation-Construction, environment & Rural Development, Public health, Medical science & education etc.

Development of Scientific temper and scientific attitude in daily life among the people are very much important for Socio-economic development of the citizen of the Gujarat state. It is also important and very much required to create awareness among the people about removal of prevailing superstitions from the society through scientific approach so that Socio-economic development can take place.

Necessity of planned campaign in different regions of the state is felt for maintaining and increasing the continuous efforts as one of the option for creating awareness among the people. With an objective to accomplish this work, the state government feels it essential to set up and maintain the structure of community science centers covering the whole state. In context of the said requirement, establishment of community science centers of various levels in the state is considered through public private partnership.

### Functions and Duties

Functions and duties of regional / district level community science centre shall be as following:

#### (A) Regional Level:

1. Execution of all the activities as mentioned in the functions of district level community science centre at headquarter and nearby area.
2. Development of activity modules of new science and its awareness programmes and providing the same at district level centers.
3. Organizing training / seminar / lectures at various stages to train the communicators of district level.
4. Keep updated with scientific activities of other state and transferring the same to district centers.
5. Getting quarterly information of the activities of the district centers and providing necessary guidance. Making efforts to boost-up their activities.
6. Separate planning of activities for district centers for each quarter. Execution and coordination for continuation of the activities in district centers as per said planning.

7. Coordination of district level activities in the districts where science centre does not exist. To provide motivation and encouragement to the interested organizations of the district.
8. Publication of books and magazines which develops scientific temper.

**(B) District Level:**

1. To organize scientific activities considering students of different age group, women and common people at community science centre and rural places of different “talukas”.
2. To establish science clubs involving schools and different agencies.
3. To organize popular lectures / science dramas / street plays or other programmes regarding superstitions removal.
4. To provide scientific guidance about the natural occurrences like earthquake, eclipse, cyclone, astronomy etc.
5. Programmes like Quiz, Elocution competition, Science Exhibition, science lectures, science related different competitions, celebration of the events related to inventions and inventors etc. shall have to be executed through science clubs.
6. To organize awareness programmes for healthcare, food and nutrition, diseases and resistance power etc.
7. To organize programmes regarding soil conservation, water harvesting and management, environment etc.
8. Entrepreneurship development and training according to local needs.
9. To organize awareness programmes regarding agriculture and organic farming.
10. Special awareness programmes for the rural and tribal community may be organized.
11. To spread awareness through video van programme.
12. Other scientific programmes, lectures, demonstrations may be organized.
13. All the Planning may be done in contact and in collaboration with respective regional community science centre.

14. Programmes conducted through application of EDUSAT may be done in contact with GUJCOST.
15. To demonstrate video films about scientific activities.

**Financial assistance provided by GUJCOST**

	Capital Grant (Rs.)	Recurring Grant (Rs.)	Total Rs.
First Three Years	1,25,000/- (25 %)	3,75,000/- (75 %)	5,00,000/-
Forth Year and afterwards	75,000/- (15 %)	4,25,000/- (85 %)	5,00,000/-

**District Level Community Science Centre**

	Capital Grant (Rs.)	Recurring Grant (Rs.)	Total Rs.
First Three Years	1,87,500/- (25 %)	5,62,500/- (75 %)	7,50,000/-
Forth Year and afterwards	1,12,500/- (15 %)	6,37,500/- (85 %)	7,50,000/-

**Regional Level Community Science Centre**

**Advisory Committee**

1. Advisor, GUJCOST / Representative
2. District Education Officer / Representative
3. Principal, District Institute for Education and Training (DIET)
4. University Dean of Science Faculty / Principal of the engineering / polytechnic college nearby.
5. Director of the district institute involved in the activities of rural development / Representative.
6. Superintendent of the Civil Hospital / Reputed Doctor.
7. Manager of the District Industry Centre / Representative.
8. District Planning Officer / Representative.

## Building and Equipments

### Building

Following shall be minimum requirements of building for community science centre at district or regional level.

#### (A) Regional Level

It is essential to have an independent building which can accommodate the following.

Laboratory room-4 (Physics, Chemistry, Biology, Maths), Laboratory equipped with audio-visual equipments -1, Workshop-1, Museum room-1, Lecture room-2, Library room-1, Office room-1 etc.

#### (B) District Level

It is essential to have an independent building which can accommodate the following.

Laboratory -2, Lecture room-1, Mini Library -1, Museum room-1, Office room-1, and if possible then workshop-1 etc.

### Equipments

#### (A) Regional Level

1. All equipments for experiment up to the higher secondary level.
2. Computer with internet facility.
3. Multimedia Projector-1, Over Head Projector-1, Slide Projector-1.
4. T.V, V.C.R., Screen, Radio, Tape, Sound System.
5. Essential equipments for workshop.
6. Museum with 40 to50 working models.
7. Library having the reading facility with 40 to 50 magazines and 3 to 4 thousands books.
8. Essential furniture for laboratory.

#### (B) District Level

1. Equipments for experiment up to secondary level.
2. Multimedia Projector-1,
3. Over Head Projector-1, Slide Projector-1 and screen.
4. T.V and V.C.R., Sound System.
5. Museum with 25 to 30 working models.

6. Library having the reading facility with 20 to 25 magazines and about 1000 science related books.
7. Mini workshop or Essential equipments.

## Operational Structure of Community Science Centers

### (A) Regional Level Science Centers

No.	Designation	Qualification
1.	Chairman (Honorary)	--
2.	Science Communicators (3)	M.Sc. or B.Sc. with 2 years experience
3.	Assistant (1)	Std-12 <sup>th</sup> pass
4.	Hamal (1)	--

### (B) District Level Science Centers

No.	Designation	Qualification
1.	Chairman (Honorary)	--
2.	Science Communicators (2)	M.Sc. or B.Sc. with 2 years experience
3.	Assistant (1)	Std-12 <sup>th</sup> pass
4.	Hamal (1)	--

### Purchase Committee

1. Advisor, GUJCOST / Representative
2. Chairman of the Community Science Centre / Vice Chairman / Coordinator.
3. Trustee of the trust governing community Science Centre.
4. Principal / Representative of the Science / Engineering / Polytechnic College / Secondary School nearby.
5. Principal / Representative of the District Institute for Education and Training (DIET).

### Subjects of the Programmes

#### Popular lecture series / Workshop / Seminar

1. Astronomy
2. Agriculture, Horticulture, Organic Farming
3. Food and Nutrition and Preservation
4. Mathematics



5. Rural Technology
6. Public health, healthcare
7. Disaster Management
8. Environment
9. Biology and Biotechnology
10. Physics
11. Medical Science
12. Nano Science and Technology
13. Chemistry
14. Water Resource Management
15. Oceanography
16. Soil conservation and Management
17. Space Technology and Application
18. Earth Science
19. Electronics
20. Information Technology
21. Energy
22. Mathematics Model Workshop
23. Fun with  
Mathematics/Physics/Chemistry
24. Mathematic show
25. Self maid equipment workshop
26. Production of Scientific Toys
27. Electronics workshop
28. House hold electronic equipment  
Workshop
29. Water harvesting, roof water harvesting ,  
farm pond and check dam
30. Introduction of herbal plants and  
preservation awareness
31. Science school
32. Origami workshop
33. Industrial work exposure
34. Research Paper reading Competition
35. Scientific career seminar
36. Formation of study groups
37. Posters/Painting/Easy Competition
38. Science Drama Competition
39. Air and water pollution.
40. Book/CD/Magazine Demonstration
41. Nature camp
42. Science Quiz/Science Seminar/Science  
Project Competitions
43. Awareness programmes for superstitions  
removal
44. Other Scientific Programmes

#### **Community Programmes & Communicators training**

1. House hold electric equipment workshop
2. Water harvesting, roof water harvesting,  
farm pond and check dam

3. soil testing workshop
4. Water Testing Workshop
5. Awareness programme for superstitions  
removal
6. Food adulteration testing workshop
7. Awareness programmes about AIDS
8. Awareness programmes about energy  
consumption/un conventional energy  
sources
9. Health camp and Awareness programmes
10. Entrepreneurship Development
11. Programmes of organic farming
12. Introduction of herbal plants and  
presentation awareness
13. Other community based Scientific  
programmes

#### **Celebration of Scientific Days**

1. World Wetland day (2nd February)
2. National Science day (28th February)
3. World Forestry day (21st March)
4. World water day (22nd March)
5. World meteorological day (23rd March)
6. World health Day (7th April)
7. Astronomy Day (21st April)
8. Earth day (22nd April)
9. International Thalassemia Day (8th May)
10. National technology Day (11th May)
11. World Telecom Day (7<sup>th</sup> May)
12. International Biodiversity Day (22nd  
May)
13. Environment Day (5<sup>th</sup> June)
14. World Population Day (11<sup>th</sup> July)
15. Ozone Day (16th September)
16. World habitat Day (1st October)
17. Wild Life Week (October 1st - 7th)
18. World Space Week (October 4<sup>th</sup> -7<sup>th</sup>)
19. National Disaster Reduction Day (10th  
October)
20. World food Day (16th October)
21. World Science Day for Peace and  
Development (10<sup>th</sup> November)
22. World AIDS Day (1st December)
23. National Energy Conservation Day (14th  
December)
24. Birth Anniversaries of Scientists

#### **Video Van Programmes, Awareness programmes of Superstitions removal**

1. Video van Programme / Exhibition and  
Demonstration of Posters and scientific  
experiment film CD.

- To create awareness about superstitious.

### Science Club related Activities

- Establishment of science clubs in school and to form a network of science clubs.
- To provide literature of math's and science and other equipments to science club.
- To organize workshop to guide students / teachers.
- To organize competition of scientific programmes for the students / teachers members of the science club.

### Minimum yearly programmes to be conducted by Community Science Centre

Sr. No.	Type of Programme	District Community Science Centre	Reg. Comm. Centre
1	Popular Lecture Series/workshop/Seminar	9	12
2	Community based Programme	6	9
3	Celebration of Scientific Days	6	9
4	Science Exhibition	5	7
5	Science Quiz /Science Seminar/Science Project Competition/Other GUJCOST Programmes	5	5
6	VIGYAN SAFAR/Video Van Programmes, Programmes of Scientific awareness about superstitions	30	45
7	Demonstration of science Experiments (Science School)	40	40
8	Establishment of science Club in school and activities	50	100
9	Communicator's training	-	02

### Community Science Centers (CSC) last three years activities

Sr. No.	Name & Address of Community Science Centers	2006-07		2007-08		2008-09	
		No. of Programmes	No. of Participants	No. of Programmes	No. of Participants	No. of Programmes	No. of Participants
1	O.V.Sheth Regional Community Science Centre, Nehru Udyan, Racecourse, Rajkot-360001	315	36938	168	31440	192	21,216
2	Community Science Centre, Aarti Society, Atmajyoti Ashram Road, Subhanpura, Vadodara-390023	305	17061	206	30134	189	22,272
3	Kalyan Regional Community Science Centre, Bhavnagar Plot No. 2232, 13/A, Daxinamurti Society No.-2, Hill Drive, Phulvadi, Bhavnagar	232	66802	224	40845	361	98,284
4	M.D.Mehta District Community Science Centre, Darbargadh, Dhrol-381210, Dist. - Jamnagar	444	62754	561	45801	551	135,400
5	Nisarg Community Science Centre, 61/3, GH-Type, Nr. Swaminarayan Mandir, Sector-23, Gandhinagar	155	54648	118	40990	181	32,689
6	Pramukhswami District Community Science Centre, Badoli, Ta.- Idar, Dist. - Sabarkantha	76	34530	45	44935	59	59,138
7	Girdharbhai Sangralay District Community Science Centre, Museum and Balbhavan, Amreli-365601	154	18309	114	44343	186	18,204
8	District Community Science Centre, Chaparda, Ta. - Visavadar, Dist. - Junagadh-362120	227	54580	284	56228	308	55,939
9	C.C.Patel Community Science Centre, Vallabh Vidyanagar, Dist. - Anand - 388120	114	8970	47	7075	62	5,987
10	Jay Bharti District Community Science Centre, Nirgun Nivas, 3 <sup>rd</sup> Floor, Dr. Tijoriwala gali, Opp. Mahila Bank, Balaji road, Lal gate, Surat	212	27144	131	35141	227	66,889
11	Dr. Homi Bhabha District Science Centre, J. P. Marg-I, Dudhrej Road, Surendranagar	67	52848	20	24578	26	27,287

12	District Community Science Centre, Palanpur Beside, Kisan oil mill, Laxmipura, Palanpur 385001. Banaskanta	144	32567	70	18183	80	25,889
13	Punaba District Community Science Centre, C/o Adarsh VidhyaSankul, Patan-384265	114	60621	42	48422	46	18,028
14	Shree Sahajanand Swami District Community Science Centre, Chhaya C/o Shree Swaminarayan Gurukul, Chhaya Main Road, At-Chhaya, Porbandar-360578	141	33574	113	28471	159	30,983
15	Prayosha Community Science Centre, Dang Swaraj Ashram Ahwa, Dang-394710	110	4461	63	29088	99	21,245
16	Community Science Centre, Swami Vivekanand Vidyavihar, Navu Sankul, Opp. Kumar Petrol Pump, Dakor Road, Nadiad, Kheda	-	-	25	3891	41	15,422
17	Kutch Mitra Community Science Center Indian Planetary Society Bhal Bhavan, Khengar park Opp. Hamirsar talav Bhuj-370001.	-	-	-	-	111	25332
	TOTAL	2,810	5,65,472	2,231	5,29,565	2,878	6,80,204

Total no. of programs conducted in last 3 years is  $2810+2231+2878 = 7919$  and no. of beneficiaries is  $565472+529565+680204 = 1775241$

## Access to Consumer Health Information: Is Information Technology Progress Enabling Cyberchondria?

I. Berezovska<sup>1</sup> and K. Buchinger<sup>2</sup>

<sup>1</sup>Department of Computer Sciences, Ternopil State Technical University

56 Ruska St., Ternopil 46001, UKRAINE

<sup>2</sup>Central/Eastern New York Lead Poisoning Prevention Resource Centre

SUNY Upstate Medical University,

Department of Pediatrics

Room 5600, 750 E. Adams Street, Syracuse, NY 13210, USA

iberezov@hotmail.com, mylibrary@earthlink.net

**Abstract.** The proliferation of consumer oriented health care information on the Internet and the deceptive ease of locating and accessing such resources through search engines have produced what is being termed a new phenomenon and a new term for this phenomenon has arisen--cyberchondria.

This paper will discuss cyberchondria in broad context and will begin to outline some of the issues facing health care information consumers, and healthcare and IT professionals related to this phenomenon.

**Keywords:** consumer health information, the internet, information seeking, cyberchondria, cyberchondriac.

### 1. Introduction

Both the positive and the negative aspects of using Information Technology (IT) and the Internet in accessing health care information are currently well recognized and actively discussed by healthcare providers, healthcare consumers, and by IT professionals. Almost all patients and their relatives, as health care consumers, are interested in online health information resources as they have become more actively involved in the decision making process regarding selection of personal optimum health-related therapy.

Promotion of information about a healthy life style also does not require as extensive publicity as it formerly did, as now many healthy persons

have also become actively involved in accessing online consumer health resources because of their desire to maintain their good health status.

Health care consumers, both the ill patient and the healthy person, are highly motivated by self-interest and play an active role in seeking biomedical information by making numerous efforts to locate the health information they need [1].

Even the most ordinary health care consumer has now become a most active online information seeker according to reports published by the Pew Internet & American Life Project (<http://www.pewinternet.org>) [2]. Since consumers can concentrate on their own health issues and problems, they may become what can be termed a consumer-specialist [3] in searching for information which they consider to be relevant to their own health status.

To be successful in searching biomedical information a health care consumer needs to develop and cultivate relevant information search retrieval and evaluation skills and should not lose common sense when applying that information to their own health situation [4].

The proliferation of health care consumer information on the Internet and the deceptive ease of locating and accessing such resources through many search engines have produced a newly identified phenomenon and a new term for this phenomenon - *cyberchondria* [5].

This paper will discuss this new term *cyberchondria* and will begin to examine several of the issues facing IT professionals, healthcare professionals and health care consumers.

## 2. Who seeks online consumer health care information?

Although the Internet is comparatively new information medium, it has become a major source of consumer health information. The exact number of online information consumers reported in published studies and polls devoted to enumerating data about Internet users who seek health information may vary slightly [6, 7] but overall this kind of user activity has been reported to be a significant proportion of the general US population. A recent Harris Poll [8] estimates that 67 % of adults in the USA, that is: 154 million people, seek health care information online. A most significant increase is reported for those who often look for information online

about health topics - from 12 % in 1998 to 22 % in 2009 [9]. Despite the fact that the most recent Harris Poll reports that there has been no increase in that trend in the last two years, the current poll data indicates tremendous growth as compared with 54 million individuals reported to be engaged in that activity in 1998. [10]

Recently, Microsoft released a study [11] indicating that health care consumers who are experienced Internet searchers but not necessarily medical experts use Internet resources to diagnose themselves with a variety of conditions and can develop anxiety and obsessive behaviours after determining they are sick based on online health information they have obtained. The Microsoft researchers labelled this phenomenon "cyberchondria" to refer to "the unfounded escalation of concerns about common symptomatology, based on the review of search results and literature on the Web" [12].

Both *cyberchondriac* and *cyberchondria*, are rather eloquent terms, and their allusion to the well known psychological terms *hypochondriac* and *hypochondria* is difficult to miss. In the wider context of illness anxiety, "also known in its more severe form as hypochondriasis;" this could be very succinctly defined as "a debilitating and chronic condition in which normal bodily symptoms are misinterpreted as signs of serious medical illness" [13]. Health care consumers with this condition "suffer with the fear that they are ill despite reassurance to the contrary and often overuse medical services in the process" [14].

Some specialists consider *cyberchondria* a new frontier in understanding illness anxiety. In that case who are *cyberchondriacs*? The Harris Poll® labels a *cyberchondriac* as anybody who had ever gone online to look for health information [15]. Does this mean that physicians or nurses using the Internet as a reference tool are *cyberchondriacs*? Such a definition and approach seems oversimplified, non-specific and questionable because many substantial matters are overlooked by such a definition.

To refine the terms *cyberchondriac* and *cyberchondria*, we suggest at minimum to take into account:

- who is the end consumer of the online search results - a consumer or his/her relatives, friends, colleagues, or a

health care professional? Is it the same person who performs the online search?

- what is the impetus or motivation to search - curiosity, self-education, self-diagnosis or professional activity in health care provision or education (since for example the Internet provides access to many materials based on evidence-based medicine for medical professionals)?
- are there any clinically significant symptoms which could make a seeker anxious about his/her health status even before doing any online search on the perceived symptoms?
- if seekers are using the data they have obtained how are they using it? - to seek treatment or to conclude that after all they do not have that particular health problem for example?

When considering the term in the context of illness anxiety, the phenomenon of *cyberchondria* seems to get a more appropriate interpretation in the Microsoft study [16]. Thus, it might be more useful to define *cyberchondriacs* as only those consumers who overuse and misuse Internet-based health care information that results in developing some manifestations of illness anxiety fuelled by online health care information they have obtained.

### **3. Is cyberchondria really a brand-new phenomenon or is it merely re-manifested illness anxiety enabled by a different information medium?**

The Microsoft study titled "Cyberchondria: Studies of the Escalation of Medical Concerns in Web Search" has placed a needed focus on public concerns regarding the safety of using health-related Internet resources. White and Horvitz write that "the Web has the potential to increase the anxieties of people who have little or no medical training, especially when a Web search is employed as a diagnostic procedure" [17]. However other media such as books and periodicals have the very same potential, and health care consumers have been displaying an innate tendency to self-diagnosis and illness anxiety prior to the development of the Internet.

For example, the main character of "Three Men in a Boat", written by Jerome K. Jerome in

1889, had much to say about illness anxiety. The main character states- "I remember going to the British Museum one day to read up the treatment for some slight ailment of which I had a touch ...I plodded conscientiously through the twenty-six letters, and the only malady I could conclude I had not got was housemaid's knee...I had walked into that reading-room a happy, healthy man. I crawled out a decrepit wreck" [18].

Neither the Internet, nor its users are unique in this respect, although the popularization of the Internet may accelerate a pre-existing trend - the fact that people used to over-react to health and disease information. The so-called "medical school syndrome" is another example of this tendency. As soon as medical students learn how to diagnose diseases, many of them are get anxious about themselves as manifesting the very symptoms of the various health problems they are studying.

A theory of heuristics, developed in the 1970s, provides a possible explanation of this behaviour based on cognitive bias or availability heuristics [19]. Availability heuristics states that people are more likely to believe something is true if it is easy to imagine. Descriptions of sickness and disease tend to fire people's imagination far more than mental images of routine life and the dramatic nature of the manifestations of serious disease inspire people's fancy and imagination to an even greater degree. Once Internet users retrieve information about a serious disease, they will often more readily suppose it a most plausible explanation of their health concerns or perceived symptomatology.

### **4. Further need to develop search and evaluation guidelines for health care consumers**

It may seem paradoxical that only 15% of health care consumers "always" check the reliability of the sources of the health information they find online, while another 10% do so "most of the time". Yet most (three-quarters) of health care consumers check the information "only sometimes", "hardly ever" or "never" [20], indicating that they often rely on potentially unreliable health information. Nevertheless, according to the Harris Poll [21], in 2009 the majority of health information consumers (83%) report that their search for information online was successful, and most

seekers (87%) believe that this information was reliable. Unfortunately, a users' opinion of success can't make the content of a web-site any more credible.

There are no generally accepted objective measures of how accurate, credible and reliable the information provided on consumer health web-sites is in actuality. Extensive research on developing a theoretical framework by which credibility in health care web-sites can be evaluated is currently ongoing [22], but consumers' behaviour regarding actual use of online health content, the relevancy of search terminology and the selection criteria must be further researched. Meanwhile millions of ordinary people as health care consumers keep accessing and using online health resources, and they are in dire need of pragmatic and easy-to-use search tools and evaluation guidelines to assure that the end result is credible and ultimately does no harm. The Medical Library Association has developed one such user guide [23]. A set of guidelines has been developed for evaluating the content of health-related web-sites based on simple criteria such as sponsorship, currency, factual information and audience. These MLA guidelines also provide tips on how to filter search results to a manageable number through the use of health subsets found in search engines such as Google or Yahoo and information about the use of general health information finding tools such as MEDLINEplus or Healthfinder.

## 5. Conclusion

The Microsoft study authors concluded that it is the architects of search engines who have the responsibility to ensure that the escalation of illness anxiety through searching the Web is prevented - "Search engine architects have a responsibility to ensure that searchers do not experience unnecessary concern generated by the ranking algorithms their engine uses" [24].

A word of caution however seems appropriate in that regard. It is important to remember that no advances in "document ranking, user modelling, machine learning, and user interface design" would make a search engine able to reason based on an individual medical history and other external factors in the way a healthcare provider can. The Microsoft researchers state that the search engine architects must be "focused on

serving medical search results that are reliable, complete, and timely, as well as topically relevant" [25]. Search engine architects should not impose their values on Internet users but simply do their professional work to provide health care consumers with the health information they need to make an informed decision about their health status in conjunction with their health care providers.

Another conclusion of the Microsoft study is that "the use of Web search as a diagnostic procedure—where queries describing symptoms are input and the rank and information of results are interpreted as diagnostic conclusions—can lead users to believe that common symptoms are likely the result of serious illnesses"[26]. Here it is an opportune moment to note that consumer health web-resources are not designed to be a diagnostic tool, and any respectable health care web site has a disclaimer section explaining its use policy.

For example, the MayoClinic.com web-site informs its users that:

"This site and its services are for consumer educational use only. Nothing contained in this site is or should be considered, or used as a substitute for, medical advice, diagnosis or treatment. The services provided on this site are here to educate consumers on health care and medical issues that may affect their daily lives. This site and its services do not constitute the practice of any medical, nursing or other professional health care advice, diagnosis or treatment...We advise users to always seek the advice of a physician or other qualified health care provider with any questions regarding personal health or medical conditions. Never disregard, avoid or delay in obtaining medical advice from your doctor or other qualified health care provider because of something you have read on this site. If you have or suspect that you have a medical problem or condition, please contact a qualified health care professional immediately" [27].

It is obvious that while search engine architects have many responsibilities, health care consumers who search for information online have their responsibilities as well. In particular, online health care consumers are responsible for: reading a website disclaimer; critical evaluation

of their searching skill ability; realizing if their educational background is sufficient to properly understand content of web-resources they have located; examination of the credibility of the information retrieved. Any deficit in these areas are a red flag to the health care consumer to utilize professional help in the process of retrieving credible information and in applying such information to their own health or illness situation by eliciting discussion with their healthcare professionals.

An obvious question that emerges from accessing online health information is "What harm could it do?" Medical librarians were one of the first groups of health care related professionals to realize the challenge of providing health care consumers with balanced access to different sources of reliable health-related information especially in health matters where there is controversy and ongoing debate such as that which is found in alternative medicine. There is a plethora of alternative health information available on the Internet that is currently outside of the accepted or evidence-based medical therapy. Even if there is no harm done accessing such health information we should, as librarians, be assisting health care consumers to access credible scientifically based information so that current conventional medical information can be presented to consumers to counter-act the indirect but no less damaging harm of less than credible alternative health information resources that "suggest that mainstream treatments are either harmful or unnecessary to a patient being treated with alternative treatment methods... This viewpoint can be harmful to members of the public; who, without information challenging the validity of alternative methods of treatment, may make poor health choices" [28].

Although medical librarians have gained extensive experience in helping consumers to choose the most reliable information available, similar professional responsibility continues to be a difficult challenge in relation to online resources that are seemingly countless in number, have rapidly changing content, where review of online publications is less formal even when there is any consistency in so doing, and there are countless healthcare consumers who are seeking information independently without professional guidance in their online searches for information.

It seems clear that health care consumers need to be given effective search tools and powerful criteria to assist them in evaluating the reliability of information they access online. It is apparent that consumers need to be encouraged to use such tools and criteria and educated to use both common sense when applying it to their health status and in learning to seek professional guidance from health care professionals before, during and after their information searches.

*Cyberchondria* is perhaps a re-manifestation of an age old problem in human nature related to illness anxiety. However, it needs further examination and discussion by IT professionals and medical librarians in order to avoid the waste of scarce or precious health care resources, valuable time and effort, and to assure that it is not being enabled by technical progress made by those professions.

## 6. References

- [1] McKinstry B. Do patients wish to be involved in decision making in the consultation? *BMJ* 2000; 321: 867-871.
- [2] Pew Internet & American Life Project. <http://www.pewinternet.org> [08/18/2009].
- [3] Calabretta N. Consumer-driven, patient-centered health care in the age of electronic information. *Journal Med Libr Assoc* 2002 Jan; 90(1):32-7.
- [4] Medical Library Association. A User's Guide to Finding and Evaluating Health Information on the Web. Last Updated: 2009 August 20. <http://www.mlanet.org/resources/userguide.html> [09/08/2009].
- [5] The Harris Poll®. Internet Provides Public with Health Care Information that They Value and Trust and Which Often Stimulates Discussion with Their Doctors. 2009 Harris Interactive, Inc. [http://harrisinteractive.com/harris\\_poll/pubs/Harris\\_Poll\\_2009\\_07\\_28.pdf](http://harrisinteractive.com/harris_poll/pubs/Harris_Poll_2009_07_28.pdf) [08/18/2009].
- [6] The Harris Poll®. 2009.
- [7] Fox S. Online Health Search 2006. Pew Internet & American Life Project. Oct. 29, 2006. <http://www.pewinternet.org/Reports/2006/Online-Health-Search-2006.aspx> [09/08/2009].
- [8] The Harris Poll®. 2009.
- [9] The Harris Poll®. 2009.
- [10] The Harris Poll®. 2009.

- [11] White R., Horvitz E. Cyberchondria: studies of the escalation of medical concerns in web search. Microsoft Research. 1 November 2008. <http://research.microsoft.com/apps/pubs/default.aspx?id=76529> [08/18/2009].
- [12] White and Horvitz.
- [13] Harding KJ, Skritskaya N, Doherty E, Fallon BA. Advances in understanding illness anxiety. *Curr Psychiatry Rep.* 2008 Aug;10(4):311-7.
- [14] Harding KJ, Skritskaya N, Doherty E, Fallon BA.
- [15] The Harris Poll®. 2009.
- [16] White and Horvitz.
- [17] White and Horvitz.
- [18] Jerome JK. *Three Men in a Boat: To Say Nothing of the Dog* (original pub.1889). NY: New York, Tor Book edition. 2001. Tom Doherty Associates, LLC: 2-3.
- [19] Tversky A, Kahneman D. Judgment under uncertainty: heuristics and biases. *Science* 27 1974 Sept; 185(4157):1124 – 1131.
- [20] Fox S.
- [21] The Harris Poll®. 2009.
- [22] O'Grady L. Future directions for depicting credibility in health care web sites. *Int J Med Inform.* 2006 Jan; 75(1):58-65.
- [23] Medical Library Association.
- [24] White and Horvitz.
- [25] White and Horvitz.
- [26] White and Horvitz.
- [27] MayoClinic.org.  
<http://mayoclinic.com/health/terms-of-use/AM00006> [09/08/2009].
- [28] Thompson SA, Thompson RP. Skeptical medical reference: helping patrons find critical resources for consumer health issues. *Library Philosophy and Practice* 2007. <http://www.webpages.uidaho.edu/~mbolin/thompson2.htm> [09/06/2009].
- 
- 

## CLIP – Child Learning Improvement Program

K.S. Chandra and N. Kamalesh  
Butterfly Edufields Ltd. # 43, Sarvasukhi Colony, West Marredpally 500026, INDIA  
[www.butterflyfields.com](http://www.butterflyfields.com)  
[sharat@butterflyfields.com](mailto:sharat@butterflyfields.com),  
[kamal@butterflyfields.com](mailto:kamal@butterflyfields.com)

**Abstract.** “More than 80% of kids go to government schools in India” – This makes us believe that the major change in the education can be brought only by improving the learning levels among kids in Government schools. With this belief, we embarked on implementing “CLIP-Child Learning Improvement Program” in Vijayawada Municipal schools, A.P., India. CLIP is a year-long intervention which involves hands-on-activities/ games for students in 6<sup>th</sup> grade & 7<sup>th</sup> grade based on their academic curriculum. While the project is being funded by Janyaa ([www.janyaa.org](http://www.janyaa.org)), Butterfly Fields ([www.butterflyfields.com](http://www.butterflyfields.com)) has evolved as the sole architect of this program. Main aim of this program is to improve the learning/understanding levels among the kids using hands on activities and games as the norm of pedagogy.

**Keywords:** hands-on-learning.

### 1. Introduction

Over the past few decades after the liberalization of our country, though India has seen tremendous growth in various sectors like Telecom, Software, Trade, Transportation etc.; Primary Education Sector which produces tomorrow's nation builders has stayed far from the growth cycle. Mid day meal and free education for all till the age of 14 can be stated as some of the recent developments in the education sector, which is trying to provide a learning environment for kids. In the core area of

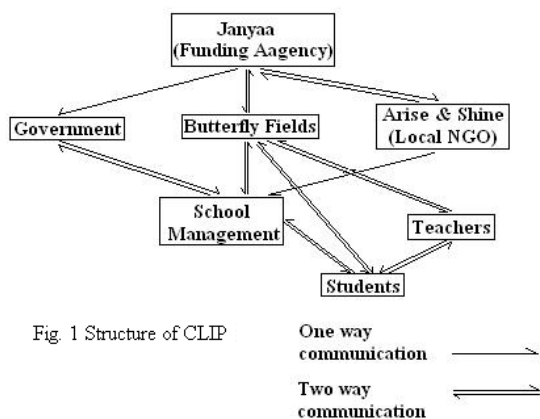


enhancing student learning, there is a lot more that can happen.

CLIP aims at taking these products & services to enhance student learning to government schools. A pilot project of CLIP is presently being implemented in four Vijayawada Municipal Schools. This is one of the important pilots for Butterfly Fields as it helps in testing various hypotheses relating to the scaling up of hands on learning. Success of this pilot will help in determining & perfecting a model for government schools where 80% of learning happens in our country.

## 2. Project Structure

Various stakeholders are involved in this project starting with the Municipal Corporation, NGOs and Private Organizations. Butterfly Fields is the implementing organization of the program and also coordinates between Janyaa (Sponsors), School Management and Teachers. Fig. 1 depicts the relationship diagram across the different stakeholders in this project.



### 2.1. Janyaa

Janyaa is the NGO based out of US, which funds different programs in schools aimed at enhancing the quality of Education (learning). Approvals from the Municipal Corporation (Govt.), selection of schools, budgeting etc. are done by Janyaa. A local NGO, Arise and Shine play a key role in the selection of the schools and the initial

coordination with the school principals in kick starting the program.

### 2.2. Butterfly Fields

Butterfly Fields believes in learning by doing. Programs offered by Butterfly fields comprise of various activities and experiences which are specifically designed to make the child understand the underlying concepts or principles and at the same time, enjoying them. A hands-on approach to problem solving and conceptualization is what is practiced and preached.

### 2.3. Schools

Based on various parameters like infrastructure, class X pass percentage, number of students, numbers of teachers, etc. four Municipal schools were selected for the pilot project in Vijayawada. Details of the participant schools are mentioned in Table 1.

School	No. of Students (VI + VII)
<i>B.V.Subba Reddy MCH School, Kandrika</i>	300
<i>M.K.Beig MCH School, Ajit Singh Nagar</i>	150
<i>B.S.R.K. MCH School Mogalraj Puram</i>	224
<i>G.Subba Reddy MCH School, Mutyalampadu</i>	118

Table 1 Details of Participating Schools

## 3. Challenges

A set of challenging problems were encountered and are still encountering, as the project is still in progress, starting from managing expectations of multiple stakeholders (Bureaucracy, School Management, Teaching Staff, Students, Donors, Local Trainers & Support People), lack of motivation amongst kids to increasing teacher involvement.

Most of the problems are common to schools viz.:

- Lack of sufficient number of class rooms
- Inadequately staffed, because of which

Multi level multi grade scenarios arise.

- Barely Visible Black Boards

-

The question which one could pose is “Are they being offered CAKE (Hands-On Activities) when they don’t even have BREAD (basic infrastructure & facilities)?”

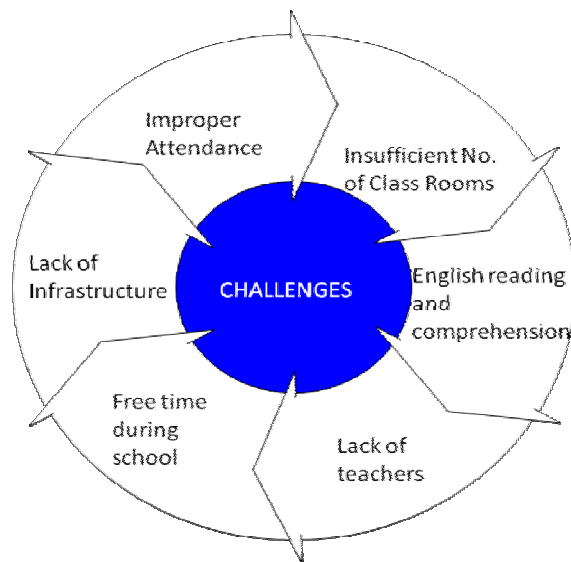


Fig. 2 Challenges

Below pictures illustrate some of these problems.



Fig. 3 Students sitting in open space

In this hostile environment, students lack motivation to attend classes regularly and study well. In addition to this, teachers are often under a constant pressure of completion of syllabus.



Fig. 4 Broken Rooms of Classrooms

Out of the 10 randomly picked students from 6<sup>th</sup> & 7<sup>th</sup> standards nine couldn’t even read, leave aside comprehension, a simple English sentence shown in the book (Fig. 5).

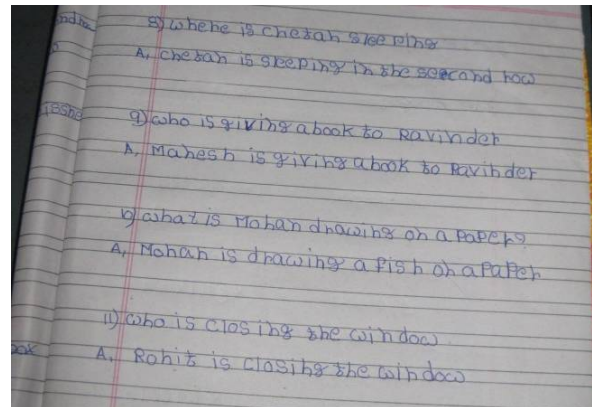


Fig. 5 Nine out of Ten couldn’t read simple comprehension

#### 4. Implementation

The pilot project started in March 2009 with a basic survey of the schools, seeking permissions from local Govt. authorities, orientation workshops for the Teachers & School Heads (Fig. 6), conducting diagnostic test and identification of problem areas for kids.

The total number of students being impacted in this pilot project is close to 750 across these four schools. Based on the diagnostic and inputs from teachers of these schools a strategy was evolved to improve the basic learning and understanding levels among children & the key tool was “Learning by Doing”. As part of the

program, 20 hands on activities related to science and math for grade 6 and 7 would be conducted of which 8 have been completed already. There are 3 assessment tests planned at regular intervals to check the progress out of which the first one was already conducted.



**Fig. 6. 2day workshop for government school teachers held at M.K.Beig MCH School on 10<sup>th</sup> & 11<sup>th</sup> July '09**

Basic concepts in math and science are being dealt with as part of the program. Apart from improving the basic understanding of math and science concepts, these hands on activities envisage the increase in creative visualization, motor skills and problem solving skills in kids over a period of time. These hands-on activities also help in increasing the level of intrinsic motivation, general awareness and overall interest on the subject for the children which can play a key role in the reduction of the student drop-out rate and overall pass percentage.

Four math and four science activities are completed as part of the program till date. Details of the activities are shown in Table 2 and Table 3.

Date	Math Topic	Math Activity
July 21 <sup>st</sup> -25 <sup>th</sup>	Integers	Jungle Maze
Aug 10 <sup>th</sup> -13 <sup>th</sup>	Geometrical Structures	Straw Models
Aug 19 <sup>th</sup> -22 <sup>nd</sup>	Geometrical Shapes	Cardboard Shapes

Sep 1 <sup>st</sup> -8 <sup>th</sup>	Algebra	Algebraic Tiles
--------------------------------------	---------	-----------------

**Table 2 Details of Math Activities**

Date	Science Topic	Science Activity
July 21 <sup>st</sup> -25 <sup>th</sup>	Fibre to Fabric	Weaving
Aug 10 <sup>th</sup> -13 <sup>th</sup>	Air Around Us	Wind Vane
Aug 19 <sup>th</sup> -22 <sup>nd</sup>	Water Around Us	Straw Pump
Sep 1 <sup>st</sup> -8 <sup>th</sup>	Digestive System for 6 <sup>th</sup> ; Acids & Bases for 7 <sup>th</sup>	IDL & Acid/Bases Tests

**Table 3 Details of Science Activities**

Teachers and management have been positive with the progress of these hands on activity sessions. Of course Students have shown lot of enthusiasm & initiative to do the activities. Some of the pictures taken during the activity session are shown in Fig. 7, Fig. 8 and Fig. 9.



**Fig. 7 Girl displaying her fabric model**

As the system evolved, we transformed direct class room teaching into video sessions (Fig. 10) which has an immense potential of scaling up. With consistent

efforts, it was possible to get more involvement of teachers in this program, who are now the champions of this program in their respective schools. From initial scepticism to the current optimism the drift has been gradual but noteworthy.



Fig. 8. Students displaying their 3D models



Fig. 9. Student with his cube model



Fig. 10. Video Session on Digestive System

#### 4.1. Feedback Forms

Feedback forms were introduced to increase the teachers' involvement in the activities.

A sample feedback is shown in Appendix.

#### 5. Tests

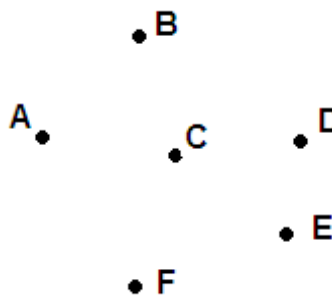
Two tests, one at the start of the program and the other after six activities, were conducted to keep track of learning among students. These tests were aimed at assessing their understanding and thinking abilities, application skills and not rote learning.

##### 5.1. Diagnostic Test

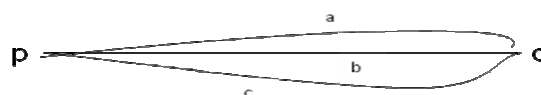
A diagnostic test was conducted in between 21<sup>st</sup> July – 25<sup>th</sup> July Diagnostic test was for 30 marks and was prepared taking prior grade text books as reference for the current class i.e. class V text books are taken as reference for class VI paper and class VI text books for class VII.

##### 5.1.1 Sample Questions

- The sum of the measures of the angles  $\angle CDF$ ,  $\angle DFC$  and  $\angle FCD =$



- Which path is the shortest one from P to Q?



- Cost of an article is increased by certain percentage and then decreased by the same % and sold. The final price would be \_\_\_\_\_ (more / less/ equal) to the original price.

5.1.2 Insights from diagnostic test

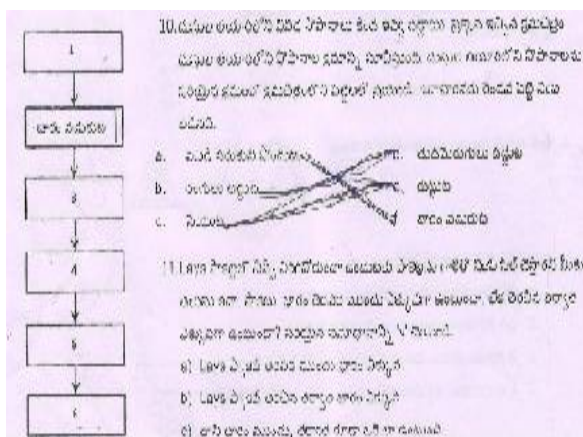
It seemed that most of the kids were unable to understand questions (though the question paper was in their mother tongue) while some of the kids were not even able to read. Some of the students couldn't even read the question paper (which was in Telugu/English). 15% of the students got "ZERO." Students could answer simple questions when asked orally after the test but couldn't read the same in the test paper. Basic operations in math seem to be a problem for most of the students. Simple questions on multiplication and addition were not solved.

5.2 Assessment Test

Assessment Test was conducted in between 1<sup>st</sup> Sep – 8<sup>th</sup> Sep. Test paper was based on the first 6 topics covered through activities. Test was for 20 marks, with equal distribution of marks across topics. Since the initial sets of activities conducted were common for both 6<sup>th</sup> and 7<sup>th</sup> grades the same question paper was given to both 6<sup>th</sup> & 7<sup>th</sup>.

5.2.1 Insights

The basic problem of students being unable to understand the questions remained even in the Assessment test.



Q. Students were supposed to fill the six steps of fabric making in order in the table shown in Fig. 11, but most of the kids thought it was a *match the following* question (as the options were given in two columns).

Fig. 11 Question on Fibre to Fabric

Q. Students were confused of questions like that in Fig. 12 which appears is different from the regular multiple choice questions.

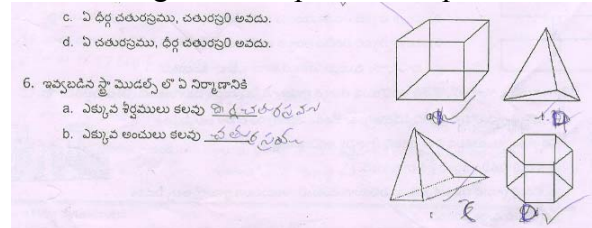


Fig. 12 Question different from regular MCQ's

Students were confused with the options (a,b,c,d) and the sub question letters 6a, 6b.

6. Analysis

On comparison of the results of first assessment test with diagnostic test it was concluded that the average performance in science doubled through the hands on activities. This was mainly due to higher student involvement and novelty of "learning by doing" for the kids of these schools. The improvement in math was marginal and the reason for that was traced to lack of basic skills in math operations program pertaining to concepts of lower grades. This has made us refine the activities to cater to the basic concepts first before starting with the activities linked to the current curriculum of grades VI & VII.

6.1. Class VI Analysis

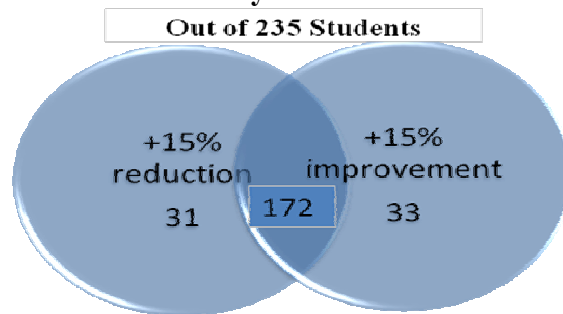


Fig. 13 Venn diagram showing class VI analysis

Out of the 235 students who took both the tests, over 33 of them showed an improvement of over 15% in their total score.

For 31 of them there was more than 15% reduction in their performance too. Of these 31 students, 27 students are from a single school BVS RK.

Detailed analysis is shown in Appendix.

### 6.2 Class VII Analysis

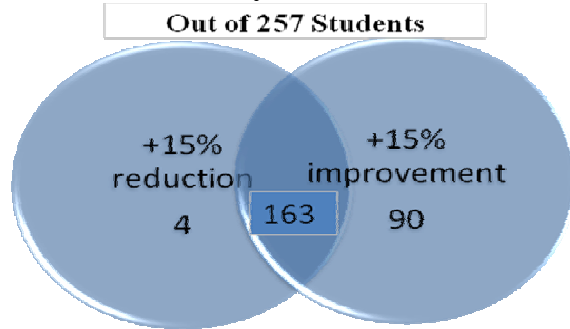


Fig. 14 Venn diagram showing class VII analysis

Out of the 257 students who took both the tests, over 90 of them showed an improvement of over 15% in their total score.

For 4 of them there was more than 15% reduction in their performance.

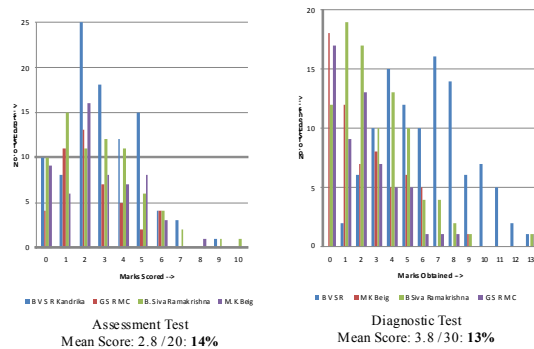
Detailed analysis is shown in Appendix.

### 7. Summary

The start was shaky with all sorts of resistance from the system, but there is a significant amount of progress in the past few months (after looking at the results) with teachers showing greater involvement and management appreciating the work and rendering cooperation. Now there are a number of things under consideration viz. the use of multimedia resources along with hands-on activities to scale up this model by next academic year.

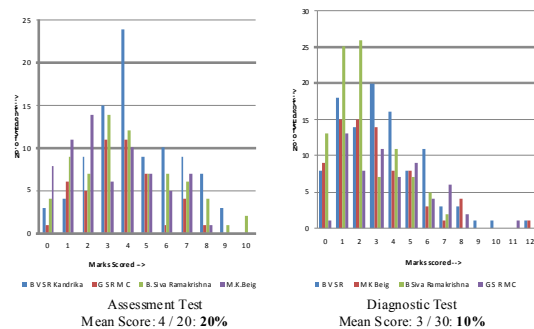
### Appendix

#### Comparison of Overall Means – Class VI



\*Diagnostic marks are averaged to 20marks as assessment was for 20marks.

#### Comparison of Overall Means – Grade VII



\*Diagnostic marks are averaged to 20marks as assessment was for 20marks.

CLIP Feedback Butterfly Fields - Janyaa

Dear Sir/Madam,

We thank you for your cooperation & support for the program. To improve the output of the program we need your valuable suggestions and feedback. We request you to spare some time and fill in the form below.

**Student Session Feedback**

School / Class / Section: *G.S.R.H.C. VII class* No. of students: *55*

Activity Name: *Area of cube & cuboid* Name of BF Trainer: *Komallesh + Harsha*

Circle / Tick mark your response:

Is the Activity conducted related to the Theory being taught in School?	High	Average	Low
Are students able to relate to the concept?	Most of them	About half of them	Very Few
Is the time sufficient for conducting the activity?	Yes	No	
Is the space sufficient / proper for the activity?	Yes	No	
Are the trainers able to communicate the concept/activity properly?	Very well	Good Enough	Not at all
What %age of students finished the Activity?	> 60%	33% - 66%	< 33%
If the material is provided and you have to conduct the activity would you be able to do the same?	Yes	No	

Any other Comments / Suggestions:  
*More teachers are need to control and explain them. please take the August syllabus to teach.*

Name of the Teacher: *V. padmeja*

Signature & Date: *V. padmeja 22/08/09.*

www.butterflyfields.com

## An Interactive Educational Environment for Teaching Psychoacoustics

C. Mousas, A. Floros, M. Arvanitis  
and T.V. Ionian  
University, 49100 Corfu, GREECE  
floros@ionio.gr, micharv@ionio.gr

**Abstract.** “iSee” is an interactive educational sound installation environment that aims to support undergraduate courses related to acoustics and psychoacoustics by demonstrating well-known psychoacoustics phenomena in real-time. The interaction environment and rules are based on spatial information derived by the instantaneous user position relative to a virtual navigation grid pattern that covers the installation space. This allows easy navigation and experiment selection, as well as simplified demonstration’s control, two highly-required features for achieving better student acoustic perception and performance. The installation core is a software module which employs advanced audio and video processing techniques for realizing the interactive experimental environment. An additional visual software component is responsible for reproducing appropriately designed visual effects, which aim to enhance the participants’ comprehension and create a visual impression of the experiments’ results. In this work, the iSee platform was demonstrated using three well-known psychoacoustics effects as test-cases, allowing its overall performance assessment as an advanced tool for educational purposes.

**Keywords:** interactive education, psycho-acoustic demonstration.

### 1. Introduction

Technology has long played a significant role in developing new digital applications for almost every aspect of human every-day life. Focusing on modern educational trends, the observed growth and continuous evolution of digital media technologies represent an attractive and fundamental scientific / technological framework for realizing advanced educational context representations and for generally re-defining the learning-process supporting means [1]. Typical

related technologies include high-definition video standards and multichannel audio formats [2], which are becoming widely accepted by both the media-producers’ and the end-users’ market. However, nowadays, the basic principle for developing novel and innovative means of educational context is interaction, which aims to render the student / participant an active part of the learning process that partially or fully controls the scenario and the “intended” context flow [3] – [4], according to his needs.

More specifically, the concept of interaction combined with new digital media technologies can be efficiently applied to and integrated with modern educational procedures that employ audio and visual information cues for representing complicated terms and topics. For example, a recent work [5] has introduced a methodology for realizing an interactive, dynamic representation of mathematical concepts. From a more general point of view, typical educational application examples can include virtually-synthesized audiovisual environments that efficiently present or simulate the desired topic based on the student / participant interaction.

Extending the above educational perspective, in this work we introduce a novel interactive platform for demonstrating typical psychoacoustics phenomena, basically as the practical part of a university course on psychoacoustics. The proposed platform is termed iSEE (interactive pSychoacoustics Educational Environment – see Figure 1). Compared to legacy demonstration means of psychoacoustic topics, the proposed iSEE platform accents the key-points of the psychoacoustic phenomenon under test by allowing the student to interact and control the parameters of the experiment without using specific hardware or traditional computer-based user interfaces.

The iSEE interactive platform presentation is here mainly performed in technological terms, typically focusing on the platform architecture and some design / algorithmic issues and concepts. Additionally, during this work we investigated the demonstration efficiency under real-world conditions during an audiovisual exhibition organized by the department of Audiovisual arts, Ionian University, by considering three well-known psychoacoustics phenomena: a) the precedence effect b) the tonal

beat perception and c) the audibility of the distortions induced by lossy audio compression techniques (such as the well known MPEG-1 Layer III coding). This efficiency evaluation process allowed the collection and interpretation of some observations related to the behaviour and the means of interaction of the participating audience that will allow the further development and optimization of the proposed experimental platform for realizing any kind of psychoacoustic experiment.



Figure 1. The iSEE interactive environment logo

The rest of the paper is organized as following: In Section 2, a brief theoretical description of the psychoacoustics experiments considered in this work is provided. This description will serve for the better understanding of the basic interaction algorithm that was employed for realizing the interactive educational platform which is analytically described in Section 3. Next, a demonstration of the platform interactive features is presented in Section 4, followed by a brief analysis of the functional and behavioural observations made during an installation exhibition. Finally, Section 5 concludes this work and accents further interaction and audio/visual enhancements that may be integrated within the iSEE platform.

## 2. Psychoacoustics effects in education

Teaching psychoacoustics, a topic that is strongly related to human acoustic perception, can be efficiently performed using a number of experiments that will demonstrate the various phenomena and effects of human hearing in practice. The participation of students themselves as experimental subjects allows the direct realization of these experiments in-class or at home provided that specific equipment is available. The demonstration of these experiments frequently requires the students' acquaintance with the experiment control

environment (which is nowadays very often implemented in software). Two major factors may affect the demonstration accuracy and efficiency (mainly in terms of the achieved student perception): a) the large number of the demonstration repetitions that are required in order to learn how to interact with the experimental environment and b) the interaction interface simplicity that may diminish the participant attention on the experiment itself.

Both of the above factors were considered in this work in order to develop a simple navigation and control interface. In order to estimate the performance of the proposed interactive environment, three typical and well-known psychoacoustics phenomena were considered. A brief overview of these effects is provided in the next Section, aiming to further allow the description of the user interaction process within the iSee platform.

### 2.1. Precedence effect

The precedence effect [6] (also known as Haas effect), describes the human acoustic ability of correctly identifying the direction of a sound source in the presence of multiple arriving acoustic paths. More specifically, the precedence effect implies that humans localize a sound source based upon the first arriving sound, provided that the subsequent sound arrivals are within 25-35 milliseconds (the exact value depends on the sound signal types). If the late sound arrivals delay longer, then two distinct sound replicas are heard. It should be additionally noted that the Haas effect is noticeable even when the second arrival is louder than the first (even by as much as 10 dB).

From the above precedence effect overview it is clear that the relative sound arrival delay represents the fundamental interaction parameter for realizing the precedence effect interactive demonstration.

### 2.2. Tonal beat perception

When a body executes two simple harmonic oscillations described as:

$$x_1 = A \sin(2\pi f_1 t) \quad (1b)$$

and

$$x_2 = A \sin(2\pi f_2 t) \quad (1a)$$

that have the same direction and amplitude  $A$  but slightly different fundamental frequencies  $f_1$



and  $f_2$  (typically  $\Delta f = |f_1 - f_2| \leq 16\text{Hz}$ ), the final movement of the body is a peculiar oscillation called beat, with frequency equal to the average of the two original frequencies and a variable width expressed as [7]:

$$y = 2A \cos\left(2\pi \frac{f_1 - f_2}{2} t\right) \sin\left(2\pi \frac{f_1 + f_2}{2} t\right) \quad (2)$$

In this work, the interaction parameter for the tonal beat perception experiment was the distance  $\Delta f$ , allowing to experimentally identify the frequency distance threshold value for obtaining the tonal beat perception.

### 2.3. MP3-induced distortions' audibility

The MPEG-1 Layer III (or mp3) audio lossy compression algorithm takes advantage of a perceptual feature of human hearing called auditory masking [8] for reducing the amount of data required to represent audio content. The compression algorithm reduces the representation accuracy of certain frequency bands that are deemed beyond the auditory resolution ability of an average human. This method is commonly referred to as perceptual coding [9] and its accuracy strongly depends on the selected coding bit rate (p): the lower it is, the highest the amount of the audible information discarded by the psychoacoustic model.

In this work we focused on the "error" of the mp3 compression as a result of the rejection (i.e. non-coding) of an amount of audio data imposed by the psychoacoustic model. This error was measured by subtracting from the original (uncompressed) audio the data resulting from the compression and decompression scheme, that is:

$$E(p) = \text{OriginalAudio} - \text{CodedAudio}(p) \quad (3)$$

where  $\text{CodedAudio}(p)$  denotes the audio signal obtained after compressing and decompressing the original data. The interaction parameter considered here was the coding bit rate (p), which allowed the direct acoustic comparison of the mp3-induced distortions audibility as a function of the coding bit rate.

## 3. Interactive Educational Environment

### 3.1. Interaction algorithms

In order to efficiently apply user – interaction, for each psychoacoustic demonstration the basic interaction algorithm had to be developed, which

maps the values of the above-described interaction parameters to corresponding values derived by the user interaction procedure.

More specifically, for each psychoacoustic experiment, a circular area with a radius equal to R (in pixels) is virtually defined within the installation space (termed here as "proximity" area). When a user enters this area, the psychoacoustic demonstration starts, while the experimental parameters values are directly and linearly mapped to the distance between the current user position and the centre of the circular area. Table 1 shows the mapping algorithm limits for each of the experiments considered in this work.	<b>Maximum Distance (d)</b>	<b>Experimental parameter value</b>
Precedence effect	250pixels	0 – 250 msec
Tonal beat detection	250pixels	0 – 25Hz
MP3-induced distortions audibility	R/8	320, 256, 224, 192, 160, 128, 112, 96 (kbps)

Table 1. Mapping algorithm limits for each psychoacoustic demonstration

During this work, for reasons of interaction simplicity, only one interaction parameter value had to be controlled by the user, which was directly mapped to the user location within the installation room. This approach allows the without-restrictions, physical movement of the student, who needs to focus only on the demonstration itself, and not on the means he/she has to use.

It should be noted here that the distance between the user and the centre of a proximity area is hereby expressed in units of pixels, allowing the simple adaptation of the interaction algorithm within any available room. Given a set of physical dimensions, the above distance can be converted in physical distance units (i.e. meters) by appropriately calculating a constant transformation factor that depends on the pixel resolution and the range of physical distances.

Obviously, the total number of the proximity areas depends on the number of the experiments that need to be conducted within the installation. Moreover, this number is also limited by the available installation room dimensions and the desired demonstration accuracy (i.e the minimum distance difference value that is required in order to change the corresponding interaction parameter value). Figure 2 shows the graphical representation of three proximity areas, forming the virtual navigation grid of the installation. This particular proximity area arrangement was employed for the purposes of the current work.

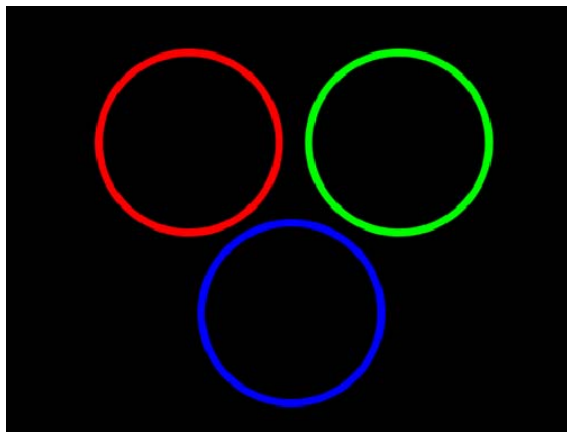


Figure 2. Schematic representation of the iSee installation navigation virtual grid

### 3.2. Interaction algorithms

Figure 3 illustrates the general architecture of the iSee interactive environment. The

fundamental subsystems are the sound and image processing / playback modules, which are responsible for creating and reproducing in real-time the appropriate audio waveforms as well as the corresponding visual effects. The latter visual channel was found to be necessary for realizing an additional feedback path to the student that interacts with the installation, as well as for providing a graphical representation of the measured results.

The software platform employed for the development of the iSee core application is the open source tool “Processing” [10]. The “Processing” development platform is used in many fields of audio and image technologies, as well as for developing interactive artistic installations. A major advantage of “Processing” is the extensive usage of optional software modules (libraries) for supporting a variety of purposes, such as real-time sound processing and playback and blob detection from video signals. The latter process was used during this work for estimating the exact position of the user/participant and for deriving his/her relative distance from the centres of the proximity areas.

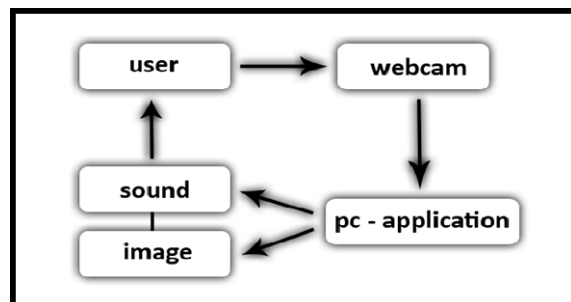


Figure 3. The architecture of the iSee interactive environment

## 4. Demonstration and results

Following the architecture presented in the previous Section, the iSee installation was realized and demonstrated for the purposes of this work in a typical closed room with dimensions 4 x 4 x 4 meters, which provided the necessary space for creating the virtual navigation grid illustrated in Fig. 2 with a physical radius  $R = 1\text{m}$ . The colour of the floor was selected to be bright enough in order to achieve the maximum possible visual contrast. This condition is very important for the detection of the exact student position through the blob-detection process mentioned previously.

Accordingly, a white carpet was placed on the floor in order to additionally increase the final video signal contrast. In addition, lighting in the room was normally distributed, in order to maximize the efficiency of the blob detection process. Due to the above colorations and lighting conditions, the user is not required to wear any specific type of cloth for optimizing the position detection process.

The equipment required for realizing the iSee installation is a personal computer (typically with a core2duo processor, 4GB of basic memory and ideally a high performance video/graphics card) a webcam for capturing the video signal required for the blob detection library, a video projector with a minimum resolution equal to 1024x768 pixels and two active loudspeakers for reproducing in stereo the generated audio signals.

From the above systems, the video projection system is responsible for reproducing the visual feedback channel. More specifically, when the user position is outside from all proximity areas, these areas are simply displayed in colour and the user is shown as a small, appropriately positioned dot on the display (see Figure 4). When the user enters a proximity area, this area is activated and the circles that correspond to all the proximity areas are used for monitoring the status of the experiments (i.e. for plotting in real-time audio data waveforms or for displaying several control and measured experimental parameter values).

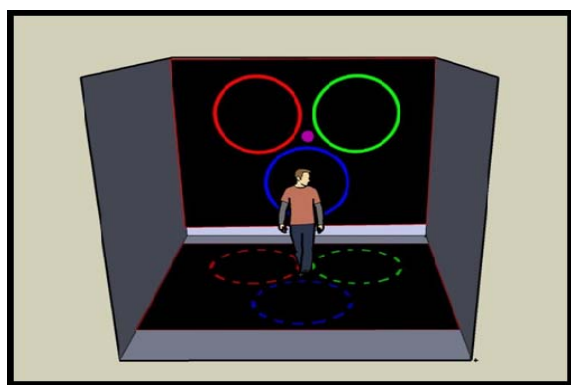


Figure 4. The iSee platform installation space

Figures 5 - 7 show typical visual outputs for all three psychoacoustics experiments considered in this work. For example, in the precedence effect demonstration case, the graph of the first circular proximity area is used for printing the numerical value of the applied delay, while the

other one illustrates this delay in terms of a distance between two vertical lines indicating the relative time positions of the two test signals. On the other hand, during the mp3-induced distortions' audibility experiment, the visual output consists of the measured energy of the lossy compression error, as well as the instantaneous error waveform calculated in real time.

In all demonstration cases, the above visual output design was finalized after a large sequence of tests and observations organized under real usage and interactions conditions with a large number of participants. Most of the participants were students that attended the psychoacoustics course that is taught at the dept. of Audiovisual Arts.

During the iSee platform demonstration, a questionnaire was filled by all the participating students. It should be noted that all the students were aware of the psychoacoustic topics considered here. The results and observations obtained from these answers can be summarized as following: a) Although most of the students had already participated in psychoacoustic demonstrations in class, the experience and perception obtained using the iSee platform was clearly the most efficient mean for subjectively estimating the effect of the experiments considered b) The simplified navigation and interaction method employed allowed the absolute focalization on the acoustic perception rather than on the control of the experimental procedure c) As a general observation, it became evident that the users believe that the iSee platform can be a significant and efficient mean for demonstrating complex topics in the area of psychoacoustics.

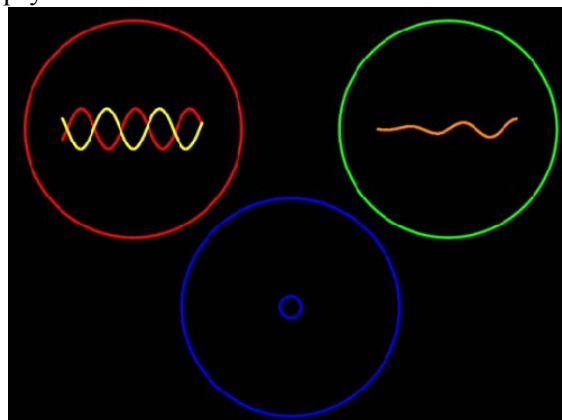


Figure 5. Example of the tonal beat perception experiment visual output

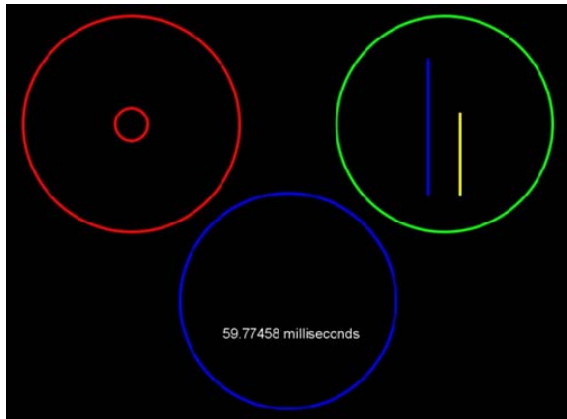


Figure 6. Example of the precedence effect experiment visual output

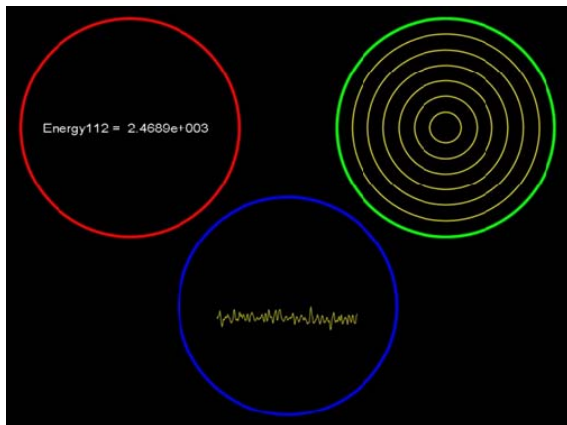


Figure 7. Example of the MP3-induced distortion perception experiment visual output

It should be also noted that the iSee installation demonstration attracted people that were not aware of psychoacoustics, which indicated that they were able to understand the demonstrated topic (especially in the case of the mp3 coding error, as it refers to a widely adopted technology).

## 5. Conclusions

In this work, the iSee (interactive pSychoacoustics Educational Environment) is introduced that aims to demonstrate common, well-known psychoacoustics phenomena in real-time. This demonstration can be a significant tool for supporting acoustic / psychoacoustic courses that with complex theoretical topics, difficult to explain using traditional educational means.

The novelty of the iSee environment is that it employs simple means of user interaction for controlling in real-time the variable parameters of the psychoacoustics experiments performed.

In order to simplify the interaction rules and minimize the time required by a user to get used to the navigation means of the installation, only the position of the participant / user relative to specific points was selected to be the interaction parameter that is directly mapped to the psychoacoustic experiment conditions.

During the psychoacoustics demonstrations, an additional visual path is providing real-time information about the current status and conditions of the experiment under progress. The existence of this information was found to be necessary for the successful demonstration of the experiments, as it represents the basic feedback path to the user, allowing a better understanding of the experiment/demonstration purposes.

Apart from the analytic technical description of the proposed interactive platform and the discussion of a number design issues and concepts, during this work the “iSee” installation was additionally demonstrated in the context of an audiovisual festival organized by the department of Audiovisual Arts, Ionian University. A number of test sessions and audience observations organized during the real-world installation demonstration have shown that the proposed interactive platform can be indeed employed for demonstrating psychoacoustics effects, i.e. as the practical part of a university course on psychoacoustics. Moreover, from the above sequence of observations, it was also found that the initial goal of simplified navigation complexity is more than adequate for demonstrating the psychoacoustics effects selected as case studies during this work.

Apart from simple demonstration purposes, the proposed iSee interactive environment can be additionally employed for conducting more complicated psychoacoustics experiments than those considered in this work, mainly by adding additional paths of interaction for controlling more experimental parameters in real-time and by developing a mechanism for real-time data / results acquisition. It is the authors’ near future intention to proceed towards this direction and provide a general real-time interactive framework for psychoacoustic experiments.

## 6. References

- [1] Bull, K.S., Kimball, S.L., and Stansberry, S., “Developing interaction in computer mediated learning”, In Proceedings of the

- American Council on Rural Special Education, Charleston (1998), SC, 18, pp. 210-217.
- [2] Yang, D. T., Kyriakakis, C. and C. C. Jay Kuo, "High-Fidelity Multichannel Audio Coding", EURASIP Book Series on Signal Processing and Communications, Volume 1, ISBN: 9789775945242.
- [3] Birchfield, D., Lorig, D., and Phillips, K., "Network Dynamics in Sustainable: a robotic sound installation", Organised Sound, 10 (2005), pp. 267-274
- [4] Boxer, A., "Art That Puts You in the Picture, Like It or Not", New York Times, April 27, 2005
- [5] Floros, A., Vlamos, P., Deligiannis, I., Arvanitis, M. and Tsiridou, T., "Bringing Digital Multimedia In Mathematics Education", Proceedings of the 7th European Conference on e-Learning (ECEL 2008), Cyprus, 5 – 6 Nov. 2008
- [6] Litovskya, R., Y. and Colburn, H., S., "The Precedence Effect", Journal of the Acoustical Society of America, 106 (4), pp. 1633 – 1654, 1999.
- [7] [http://en.wikipedia.org/wiki/Beat\\_\(acoustics\)](http://en.wikipedia.org/wiki/Beat_(acoustics)) (last accessed August 16th, 2009).
- [8] Brandenburg, K., "MP3 and AAC explained", AES 17th International Conference on High Quality Audio Coding, 1999.
- [9] Painter T. and Spanias, A., "Perceptual Coding of Digital Audio", Proceedings of the IEEE, 88 (4), pp. 451-513, April 2000.
- [10] <http://www.processing.org> (last accessed August 16th, 2009).
- 
- 

## Introducing Optics in the Kindergarten

M.F.M. Costa, J. Ayres de Campos,  
M. Lira and S. Franco  
Departamento de Física, Universidade do  
Minho, Braga, PORTUGAL  
mfcosta@fisica.uminho.pt

**Abstract.** A hands-on approach leading the students to observe experiment and discover themselves in a critical committed and active way the different aspects of light and optics should be employed at all school levels and must be the main driving pedagogical practice of all learning process of science and technology.

The introduction to our school' students of the wonders of light and optics and its understanding can and should be made as extensively as possible. As soon as at kindergarten level!

A series of experiments and support material designed in a hands-on perspective was developed to be used to introduce the study of optics to kindergarten and early basic school students. A critical evaluation of the first results of the application of these material with students aged 4 to 10 years will be presented.

### 1. Introduction

Young children are always eager to learn to see new things but also to know and to understand the world that surround them.

With reduced "pre-knowledge" usually, there are no previously acquired misconceptions or even prejudices. Also there no exams to study for... "just" the innate survival need to know. However, since they were born a permanent learning process take place at an extremely fast pace.

Children learn from the environment from what they feel from what they live. As we could see when contacting children in this age range, 4 to 10 years old, a constant reference to their every day life and previous experiences is made.

Hands-on [1,2] activities are fundamental and the "natural" approach for these young students.

The first concern of the educator should be, with this clear perspective in mind, to show... or better... to let the children to "see", to observe,

to confront themselves with new objects processes and situations.

Time is fundamental and should be generously given to the young students. Of course some “pressure” can be useful... in due time... respecting each one's pace. From early kindergarten years the children should “learn”, should be lead to work in group to interact and cooperate with peers towards a common goal.

Care however should be taken by the educator in order to ensure that each student will have, in these group activities, the needed time to establish their own “knowledge” while guarantying that no children, apparently “faster”, feels uncomfortable “waiting” for the others. No sense of superiority, or inferiority, or even of condescendence, in this competition process that always appears in these situations at these ages, should be rewarded. Yet fundamental it is that the each child understands, step by step, the importance of “cooperation”, of listening the other letting the others to know of our findings, helping and accepting to be helped in the sake of a common goal.

How to do that?... a Portuguese popular saying (certainly with equivalents throughout the world!) “words are silver, silence is gold”... be patient give time to the students, and to your self..., open widely your eyes and lead the way smoothly affirmatively and discreetly. Words might be made of silver but it is fundamental that the child is able to verbalise coherently their feelings their findings their opinions. Hands-on should be complemented with a constructivist [3] approach and others like construcionism [4] and conceptual learning [5].

“Always” hands-on but not blind/mechanically... “... do this and then that and that and...” Learning is discovering... by the student... himself... actively and reflexively.

## 2. Light and optics at the kindergarten

Being related to one of our main senses, being the eyes a major gateway to the world that surround us, light related phenomena are rather appealing to young children [6]. Young students readily realize the importance of seeing and the role of their eyes and of light sources. They are particularly attracted to the colour phenomena, to reflection and transparency, to shade and changes in luminosity...

Below we present a set of simple experiments that we designed for 4 to 10 years old students and that may serve as basis for teachers and educators to use in their classrooms and in informal activities [7].

We divided the experiments in three parts. A first one intends to introduce the role of the eye and ... we need light to see objects. At the second part we intend to show using a simple model how the eye works. Finally the third part deals with light and colours and is by the most attractive one for our young scientists.

## 3. Light and optics experiments in the kindergarten and elementary schools

### 3.1 Part 1.

The main concept behind this first set of experiments was: we need light to see objects.

The experiments were design to show that:

- We see an object because the light from the object enters the eye through the pupil. Constriction of the pupil limits the amount of light entering the eye, and dilating of the pupil allows more light to enter the eye. So, in bright light, the pupil constricts, and in darkness, the pupil dilates. (Experiment 1)

- There are objects that emit light (i.e., light sources) and others that reflect light. (Experiment 2)

- Light is reflected from the surface of objects. Dark objects reflect little light while white objects reflect more light (Experiments 3 and 4. Figure 1).

Experiment n°. 1. Pupil observation

Background: The light enters the eye through the pupil. The pupil has to adapt to different light intensities.

Method: The children are divided into groups of 2 or 3. The room light is dimmed and penlights are distributed to each group. It is asked to one of the children to illuminate his/her eyes while the others observe the pupil closing down.

Experiment n°. 2. Luminous and non-luminous objects

Background: There are objects that emit light and others that reflect light.

Method: The room is dimmed. Light emitting objects (of different types) and non-luminous objects are available and are shown. The similarities and differences between the various types of light sources and objects are discussed.

Experiment n<sup>o</sup>. 3. Brighter and darker objects

Background: The light is reflected from the surface of the objects. The dark objects reflect little light while white objects reflect more light.

Method: Several objects of different colours are placed in a black box with the front face open. The room light is dimmed leaving only a small lamp behind the box. The position of the lamp is gradually changed to allow some light to reach the objects inside the box. As the inside of the box becomes more illuminated the darker objects become progressively more visible.

Experiment n<sup>o</sup>. 4. Light reflected by objects

Background: The light is reflected from the surface of objects. The dark objects reflect little light while white objects reflect more light.

Method: In a very dark room, each child place him self in front of a mirror. One hand holds a penlight on one side of the face in order to lighten the nose. The child is asked to observe his/her face in the mirror (figure 1.).



Figure 1 - The light reflected by the objects' experiment.

The experiment is repeated by holding a white cardboard with the other hand, parallel to the side not illuminated. The procedure is then repeated by replacing the white cardboard by a black one and then by cardboards of different colours. Finally the student replace the card a by a second mirror. Children record and discuss what they saw happening on the non-illuminated part of their face when using the different colours or the second mirror.

### 3.2 Part 2.

The main goal of these set of experiments is to illustrate how our eye work

The experiments were design to show that:

- How the image of an object is focused on the retina. (Experiment 1)
- What is accommodation. (Experiment 2)

- Seeing "bad"... What is myopia and hyperopia. (Experiment 3)

These set of experiments were performed with a model of the human eye (figure 2.).



Figure 2- How the eye works experiments

Experiment n<sup>o</sup> 1. Using a bright light source (a candle may be used under teacher's supervision), images can be focused on the model's retina simulating the human eye imaging mechanism.

Experiment n<sup>o</sup> 2. To demonstrate the accommodation the lens can turn thicker or flatter to focus the image on the retina. The lens is a chamber constructed of optically clear silicone elastomer connected by tubing to a water-filled syringe. Water forced into the lens increases its thickness and curvature; withdrawal flattens the profile of the lens, changing its focus.

Experiment n<sup>o</sup> 3. The eye model can simulate refractive problems (that some children may suffer from). Myopia and hyperopia can be simulated by changing the eyes' shape (length). It is also possible to use corrective lenses. Whenever there is a child using spectacles it may be used to illustrate the correction effect (if the teacher/educator is not confident enough with the process, is probably better to skip this step unless some students points it out (which often happens... fortunately...)).

### 3.3 Part 3.

Colour is the main concept addressed at this last set of experiments.

The experiments were design to show that:

- It is easy to separate white light' colours (Experiments 1 and 2).
- We get white light by adding green, red and blue light (Experiment 3).

- Getting yellow, magenta or cyan colours (Experiment 4).

- Object' colour depends on the light reflected from them (Experiment 5).

Experiment n°. 1. White light decomposition 1.

Background: White light is “composed” of all the colours in the rainbow.

Method: Using a bright white light source (placing a slit in front may help), a beam of white light is projected onto a white smooth surface (target). With a diffraction grating and, or, a prism, the light is decomposed, projecting the light spectrum on the target (it may not be easy to get all colours clearly visible... children must learn to be patient and resilient). Colour filters are placed in front the beam and, as always..., discussed.

Experiment n°. 2. White light decomposition 2.

Background: White light is “composed” of all the colours in the rainbow.

Method: CDs are distributed to the children. They observe the decomposition of sunlight (the ceiling lamp or even the light emitted by a computer screen) into the rainbow. The experiment is then repeated with a pocket spectrometer.



Figure 3 – Colour shadows.

Experiment n°. 3. and 4. Mixing light with different colours.

Background: Adding green red and blue light allows us to get white light.

Method: Three light sources are used - one red, one green and one blue (simple flashlights with colour filter – the teacher must check ahead

how red is the red, how green is the green...). The three beams are directed to one point of a smooth, not polished, white wall or board.

Children are also asked to make shadows with their hands (figure 3.) and notice all the colours observed. The experiment is repeated with only two lamps connected at a time. The concept of subtractive colour missing may also be addressed.

Experiment n°. 5.

Background: The colour of objects depends on the light reflected from them.

Method: This experiment is done using the same light sources used before and at the same positions. Several cardboard pictures of different colours (the cardboard should not be shiny) are placed on a black board (figure 3). Those colour cards are illuminated with one of the lamps and repeated with each one of the other lamps and combinations of them. At the end the three lamps are switched on. (Especially for these two last experiments it is necessary to dim significantly room lights).

#### 4. Brief discussion and conclusion

We decided to invite a group of elementary school students (ages 6 to 10 years old) to the university in order to perform these sets of experiments.

The activity was rather successful pleasing to students and teachers. Although stating their clear preference that the colour experiments were the most pleasant ones, the results were in general very positive, during the execution itself and in the follow-up activities undertaken back at the school.



Figure 4. Demonstrations and visits to museums and science fairs might be very useful if a follow up work is prepared by the educator and conducted in classroom context.



Follow-up, in fact, should always be considered very important. These non-formal or informal activities (visits to labs, museums, science fairs or lectures, figure 4.) should always be followed of work sessions in the classroom exploring the motivation achieved and developing and or strengthening the knowledge transmitted/acquired. At the end of our activity a series of enquiries and quizzes were delivered to the teachers and asked to be returned for analysis and statistical treatment. Furthermore we distributed to the students material and short guidelines to build, on their own, a kaleidoscope and a simple pinhole camera (a muffin aluminium cup, a rubber band and a soft translucent paper sheet is enough...).

Being clear for us that the students easily and correctly are able to understand the importance of the eye in the process of seeing, we decided to explore a little bit the vision process. We used a simple model of the eye with a pupil, a rubber lens that could be inflated using a water syringe and a retina like displaceable target, which can be easily built. We expected the students to have difficulties in understanding the process or even accepting it ... we were inside the eye...! In fact only older students, 9 to 10 years old, were able to deal with it.



Figure 5. Shapes and colours.

The age span covered, 4 to 10 years old, is rather large (especially as dealing with children). One must carefully cope with the differences... being flexible but always observing child's' reactions.

From very early ages young children are strongly attracted to colours, in particular to bright principal colours, are fascinated by the wonders of colour mixing and they seem more

attracted to additive mixing opposite to what happens with school students that before being presented to the issue had previous experience in mixing ink for paintings (the subtractive process). The hands-on manipulation of colour cards (especially if being part of games) is particularly effective (figure 5.).

In general the basic concept covered by these experiments (specially part 1 and 3) are readily understood by the young children that immediately after realizing the concept present a series of examples related to their own experience (... when electricity failed and lights went off I was afraid my mama leave me alone in the dinner table...). This type of reaction happens quite often (normally older students are more "careful" expressing their feelings and ideas and restrain them selves) and is a good indication that some level of understanding of the concept was achieved.

## References

- [1] "Hands-on Science"; Costa MFM; Selected Papers on Hands-on Science (ISBN 978-989-95336-2-2); Costa MF, Dorrió BV, Michaelides P and Divjak S (Eds.); Associação Hands-on Science Network, Portugal; pp. 1-13 (2008).
- [2] Gatt S. (ed.), (2006) Primary Science Teachers Handbook, European Commission Comenius 3 project: Hands on Science Network, Malta.
- [3] "Constructivism – An effective Theory of Learning"; Gatt S; Constructivist teaching in Primary School Social Studies, Mathematics, Science, ICT, Design and Technology; Gatt S and Vella Y (Eds.), Agenda Publishers, Malta (2003).
- [4] "A Study of Educational Robotics in Elementary Schools"; Ribeiro C, Coutinho C, Costa MFM and Rocha M; Selected Papers on Hands-on Science (ISBN 978-989-95336-2-2); Costa MF, Dorrió BV, Michaelides P and Divjak S (Eds.); Associação Hands-on Science Network, Portugal; pp. 580-595 (2008).
- [5] "Teaching Physics Modelling with Graphic Simulations Tools"; Zamarro JM, Molina GJ and Núñez MJ; Selected Papers on Hands-on Science (ISBN 978-989-95336-2-2); Costa MF, Dorrió BV, Michaelides P and Divjak S

(Eds.); Associação Hands-on Science Network, Portugal; pp. 69-73 (2008).

- [6] “Learning Optics at Basic Schools by Experimentation”; Costa MFM; Selected Papers on Hands-on Science (ISBN 978-989-95336-2-2); Costa MF, Dorrio BV, Michaelides P and Divjak S (Eds.); Associação Hands-on Science Network, Portugal; pp. 25-28 (2008).
- [7] Manuel F.M. Costa, Hands-on Introduction to Optics / Introdução à Óptica (bilingual edition), Hands-on Science Network, ISBN 989 95095 2 3, Se
- 
- 

## Robotics in Child Storytelling

C.R. Ribeiro, M.F.M. Costa  
and C.Pereira-Coutinho

Instituto de Educação e Psicologia and  
Departamento de Física, Campus de Gualtar,  
Universidade do Minho, Braga,  
PORTUGAL

celiarosaribeiro@gmail.com,  
mfcosta@fisica.uminho.pt,  
ccoutinho@iep.uminho.pt

**Abstract.** Although the field of Educational Robotics (ER) has been growing over the last few years and its usefulness has been shown in many studies, its use in basic or elementary school levels has been scarce. This work intends to address the issue of demonstrating that ER makes a very useful tool at the elementary levels of learning, proposing a project-oriented approach, where interdisciplinary work uses children's stories and their imagination.

The project involved the use of Lego Mindstorms robotics kits by students with ages between 9 and 12 years old. It involved the construction and programming of robots, addressing the dramatization of the popular tales "Little Red Riding Hood" and "The Three little pigs" as the final goal. Also, other groups of students implemented fashion and dancing shows, also with robots.

Each of the robots performed as one of the characters of the story/ show, following a set of steps according to the script that was programmed by the students. The work involved also a previous step where the robots were built and “dressed” according to its role.

The final results show the applicability of ER to this level of learning/ teaching. The students were able to successfully complete the project, achieving the proposed aims and also showing high levels of motivation and enthusiasm through its whole duration. The work culminated with public shows that served as a way to involve the community.

**Keywords:** educational robotics, construction-ism, storytelling

## 1. Introduction

The interest on robotics as an educational tool has increased substantially over the last few years.

In fact, many benefits have been claimed for this tool and many researchers stress that it can be a tremendous source of energy that can be used to motivate both adults' and children's learning.

Those who have used robots say that they spent thrilling moments, the atmosphere is vibrant and that they profited much from the experience.

Many believe that this interest can be used for educational purposes (Johnson, 2003).

Yet, before recommending the massive use of this tool in the different levels of teaching and education, it is necessary to study in depth some issues related to the true effectiveness of educational robotics in promoting the acquisition of skills and knowledge.

## 2. Objectives

In general, some important issues can be raised about educational robotics, being of foremost importance the following:

- What types of contents/skills can be learned / taught used the robotics as an educational tool?
- What age levels can be contemplated with robotics activities and how this are related with the answers in the previous question?
- What are the main differences between the type of learning promoted by robotics and other ways to learn/teach?
- Which factors in the student's social context can influence her feedback to robotics activities? In particular will the student's gender be a relevant factor in his motivation level and to determine the kind of activities that will be developed?
- What kind of activities can be developed to maximize the potential of robotics as an educational tool?

It is obvious that to obtain adequate answers to all these questions can be an overwhelming task that is quite far from being concluded.

## 3. Lego Mindstorms Platform

The Lego Company has a long tradition in the development and commercialization of toys with innovative features that put together the entertainment and the pedagogical components, an aspect that was never disregarded by the company.

Lego has been selling toys that integrate electronic components for nearly 30 years. Therefore, it is not cause for admiration that the company has searched for a leading role in the educational robotics arena. With this purpose, in the beginning of the 1980's, Lego searched by the MIT a collaboration in order to be able to develop robots that could be controlled by computer programs, in a way that could be interesting for children.

This collaboration was based on the pioneering work done by Seymour Papert at the MIT, namely with the development of the Logo language that allowed to program the movements of a turtle in a computer screen. As a result of this partnership, the Lego TC Logo came up in 1986, where robots built with Lego pieces could be programmed using Logo. This collaboration provided more fruits since in 1998, also with the participation of M. Resnick, with the appearance of the first Lego Mindstorms systems, named Robotics Invention System. The large potential of the RCX, the "brain" of the kit, as well as its numerous available programming interfaces changed the landscape of its buyers. Indeed, this kit was mainly acquired by adults (Teixeira 2006).

After a short period of enthusiasm, Lego entered a period where the strategy to invest on Robotics seemed to be compromised. This period was ended in 2006, with the release of the new Lego Mindstorms kit based on a new central processing unit, the NXT, that replaced the "old" RCX.

### The Hardware of the Lego Mindstorms

The NXT is a programmable robot that has one (or more) motors enabling it to move (and much more), that can use the different sensors to get information from the environment and that is also able to emit sounds. The robot has also the capability of communicating with a personal computer, either through a cable or using the new Bluetooth communication abilities. The Lego Mindstorms kit has in its basis the following hardware components: a

microprocessor, a battery, a transformer, cables, sensors (ultrasound, touch, sound, light), motors and numerous Lego pieces for constructing different models.

### **3.2. Programming the robot: available software**

The Lego Mindstorms Education NXT software allows us to explore in depth the potential of the robot. It integrates the Robot Educator, a tutorial with 39 activities that allows any new user to learn at its own pace. The initial screen gives access to two different areas: the Robot Education with tutorials and construction plans and the work area that allows the user to freely program the NXT, using a visual programming environment.

### **3.3. Advantages of using the Lego Mindstorms robot**

The Lego Mindstorms robot fascinates all children (and adults) that contact it. It has attractive accessories that allow it to interact in several ways with the surrounding world. The available sensors allow a rich interaction between the robot and the children. There are no doubts that this can make an ideal tool to motivate students in the learning process, since it presents new challenges to develop several learning skills.

The advantages of using the Lego Mindstorms NXT robot are numerous: the fact that it is possible to use it in the classroom or outside the classroom in group work; it enables social and communication skills; it is possible to endow it with the form the users need or prefer; it facilitates a meaningful learning process; it allows multidisciplinary, interdisciplinarity and transdisciplinarity; it is useful for teaching several contents related to Mathematics, Technological Education, Physics, Biology, Chemistry, Visual Education, among others.

## **4. State of the art in Educational Robotics**

Over the last decades, in numerous places around the world, many experiments have been conducted using Robotics as an educational tool, with a special emphasis at the secondary or university levels, but involving in some cases the more elementary levels of teaching. Of course,

Robotics can be thought as another content, to teach or explain to the students, in a traditional perspective (Teixeira, 2006). This is, typically, the approach followed by some university or more technical courses related with Electronics and automation contents.

We should face Educational Robotics under the perspective of a broad tool that can be used in all teaching/ learning levels and as a way to approach several different contents. This view can be well integrated in a constructivist approach to education. According to Chella (2002), Educational Robotics can be defined as an environment with several components (the computer, the robot and other electronic artefacts, the program) where the student builds and programs its robots, interacting with all the components and exploring concepts from distinct areas of knowledge.

Competitions are the best example of initiatives that involve a large number of participants (students, teachers and parents).

They are, for this reason, privileged as tools for the divulgation of robotics next to the younger. The major competitions are the First Lego League (FLL) that involves students between the ages of 9 and 16 years old and the RoboCup Junior, where each team has two autonomous robots that play a soccer game against another team in a 3 meter field.

Beyond competitions, other research works are being developed in several schools and have resulted in scientific publications. Within these examples, there are studies where students with ages between 10 and 18 participate in extra-curricular Robotics clubs (Costa and Fernandes, 2004-2005), (Teixeira, 2006), (Silva, 2007), as well as qualitative studies approaching the construction and programming of robots by elementary school students to dramatize a popular Portuguese tale (Ribeiro, 2006).

## **5. Constructionism**

The origins of constructionism can be traced back to the group headed by Papert in the MIT in the 1960's that was well known with the development of the Logo language. This group built a vision of education based on 4 basic ideas (Bers et al 2002):

- The constructionist philosophy of education involved the creation of computational environments where children can manipulate

materials in an active way, playing with the, learning by doing, through the development of meaningful projects, shared with the community.

- The importance of concrete objects as a way to learn abstract phenomena. In this case, the computer allows creating and manipulating objects in the real and virtual worlds, thus making a tool of extreme relevance.

- The so called “powerful ideas” that reinforce the individual’s capability to learn, allowing distinct ways of thinking, of using knowledge and of creating interpersonal relationships and epistemological with other domains of knowledge (Papert, 2000).

- The importance of self-reflection that happens when people are encouraged to explore their own process of thinking and their intellectual and emotional relationship with knowledge, as well as their life story that affects the individual learning experiences.

These four principles of the constructionist philosophy are a commonly accepted basis on the elementary education levels. On the other hand, those are fundamental to the development of Robotics activities.

## 6. Potential of Educational Robotics in the teaching/ learning process

### Curricular areas

**Robotics** has been used, over its path in Education, as a tool useful for the learning of distinct contents, as well as for the acquisition of numerous skills. Within this large set, the areas of Physics, Mathematics and Informatics are normally emphasized, being the ones more directly connected with Robotics. Regarding Physics, several are the sub-fields where many of the important concepts can be approached using Robotics based activities. The tasks that the robots perform are typically related with movement, involving numerous concepts from Mechanics. Informatics is directly approached by the activities concerning the robot’s programming, as well as all the software tools involved. Underlying both fields we have the mother of all sciences, Mathematics. Robotics provides an excellent mean to make lots of different mathematical concepts, at all levels, into very tangible and useful concepts. Robotics makes possible to design activities that implement project based learning approaches.

Furthermore, Robotics also allows working concepts related to areas like Arts Education. In fact, when planning and building robots a number of skills related to these subjects come into play. On the other hand, some of the Robotics activities (e.g. competitions) have been developed in order to include Music and Dance as major areas, being approached activities that involve different types of choreographies.

### Robotics in Basic/ Elementary Schools

We believe that Robotics can be used in the teaching/ learning of some of the contents and skills related to the major areas of basic or elementary school (i.e. within the first 4-5 years with students between 6 and 10 years old). Indeed, many of the major contents from areas like Mathematics, Sciences, Languages and Arts can be included into well designed and planned Robotics activities. An analysis to the curricula in the Portuguese system (CNEB, 2001) allowed identifying, for the main curricular areas, a set of application domains, learning experiences and contributions to reach the proposed basic skills. We believe that this study detailed below can be easily transposed to other countries and teaching systems.

**Mathematics** - The emphasis on Mathematics in this level should be focused in solving problems, thinking about them and communicating with others to exchange ideas. Robotics offers a field full of opportunities, allowing working on the main skills of the different domains, such as Arithmetic, Geometry, Algebra and general problem solving.

**Sciences** – Robotics can contribute for reaching the main aims in the teaching of natural and physical sciences, such as: acquiring a general understanding of the ideas and structures that explain scientific concepts; understanding and applying the procedures of the scientific research; questioning the impact of Science and Technology in our societies. Robotics is able to provide a set of learning experiments that include planning projects with certain aims, detailing the major steps, since the definition of a problem to the understanding and divulgation of the results and doing cooperative work.

**Technological Education** – Technological Education should be built upon the development and acquisition of skills in a sequence of learning steps along the elementary school levels. These should be able to integrate concepts and skills

shared with other areas and promote the application of these concepts into new situations.

## 7. Methodology used in the study

The study we undertook is considered as a case study, since it can be included into a class of research studies where, for a number of reasons, it becomes very difficult or even impossible to generalize results, being the aim to describe a given educational phenomena. This option can be intentional or imposed by the nature of the study or by the available resources that prevent the researcher from controlling the events and manipulating the causes of the participant's behaviour (Yin, 1994). Merriam (1988) characterizes the study as a qualitative case study given its descriptive, inductive, particular and heuristic character.

### Description of the study

This study involved the development of two Robotics projects, by a group of students from the 4<sup>th</sup> and 6<sup>th</sup> grade respectively. Lego Mindstorms kits (as described before) were used in both cases. The activities took place in the 3<sup>rd</sup> period (April to June) of the curricular year of 2006/2007. A work was developed including activities of Robotics in the curriculum of the two groups of students during these 3 months. One of the groups (4<sup>th</sup> grade) belonged to the EB1/JI elementary, included in the Gonçalo Sampaio group of schools from the city of Póvoa de Lanhoso in Portugal. The other group (6<sup>th</sup> grade) belonged to the Conservatório de Música Calouste Gulbenkian in Braga, Portugal. Both studies involved the participation of the students in activities that took 2 hours per week for about 12 weeks. The project ended with a final year party, where all students from the schools were present, as well as parents and teachers.

Regarding the first group, the EB1/JI da Póvoa de Lanhoso is integrated into a group of schools where the first author was working over the last three years. The necessary robots were gently provided by a project coordinated by the University of Minho. The students opted, in this case, to dramatize a story and use this project as their contribution to the final year party. They decided to show their colleagues a different way of telling stories and chose the popular tale to the "Little Red Riding Hood". Within the group, the tasks were distributed by all: some were in charge of building the scenario (painting boxes,

drawing trees), others designed and made the clothes for the robots, others built the robots using the Lego pieces, others programmed them and others still wrote the dialogues.

These students had never had the chance to see and touch a robot previously. The project was structured into 3 major steps: the preparation of the study including learning the basic of the Lego Mindstorms platform; the development of the story telling project; and, finally, the presentation of the final result to the community.

Regarding the second group, the Conservatório de Música Calouste Gulbenkian was one of the schools participating in the project led by the University of Minho. In this school, the option was to work with a group from the 6<sup>th</sup> grade, given the openness and flexibility shown by one of the teachers in order to have an available slot on the busy schedule of these students. The students in this group were all from a medium-high socioeconomic background, but had no previous contact with Robotics. In this school, Music is a major theme and students have little available time for other activities.

The available time was of 90 minutes per week and the group had 20 students. Initially, all members of the group were together making some activities to understand the platform and know how to build and program the robots. In a second stage, the group decided on the projects they would be involved and it was decided to divide the group into two sub-groups, working on different projects: the first opted for the dramatization of the story of the "Three Little Pigs" and the second decided to do a fashion show and also a dance choreography.

Within each session, in the first 45 minutes the 1<sup>st</sup> group was preparing the scenarios, the clothes for the story, while the 2<sup>nd</sup> group was programming the robots for the fashion parade and dance. In the second part of the session, there would be a switch, and the 1<sup>st</sup> group would go and program the robots for the story (e.g. setting the path for each robot and programming the movements), while the 2<sup>nd</sup> group would work on the characterization of their characters for the fashion show and the dance. In the 1<sup>st</sup> group, the programming was made in a collaborative way, but more towards the end 5 students were selected for each character, while the other five were working more on the dialogues and synchronization with the robots movements. In

the fashion parade, they decided that each student would enter side by side with the robot and with similar clothes.

Characterization of the community and the subjects involved in the study

The students from the 4<sup>th</sup> grade had a previous history of participating in Informatics activities in their extra-curricular time in school. All students had a previous contact with computers, although there were dissimilarities within the group. This group had 11 students, 6 boys and 5 girls. To program the robots, the students made 5 groups, one per each character in the story. The groups had 2 elements (one with 3), where one of the students programmed and the other tested in the ground. They switched tasks regularly. In the final presentation, one the students were next to the robot to start it when appropriate and the other was the “voice” of the character.

This group was considered to be very noisy by their teachers, but during these activities they were always a disciplined group, obeying the rules with no problems and normally motivated by the activities and anxious to show their progress. Their previous background with computers made it easy to proceed with the programming activities. Whenever one student had any doubts, all the others were ready to help.

The 6<sup>th</sup> grade group from the Conservatório de Música Calouste Gulbenkian has good skills in working with computers. All students had a computer at home, but they had never contacted Robotics before. The group had 13 girls and 7 boys and the group division was made by alphabetical order. In general, the students had good results in their school subjects, although two of the students were weaker than the remaining. Since the first day, all students embraced the project with enthusiasm and good mood. They worked hard to develop the project in time since the weekly time was not much.

#### Data collection Instruments

In the study, distinct instruments were used to collect the data for the investigation. These were designed and implemented by the 1<sup>st</sup> author that collected all data and made its processing and interpretation. In this study, the following instruments were used: participating observation; video films of the sessions and analysis of the documents produced by the students (e.g. files with the robot programs).

In a qualitative study, the role of the researcher is primordial in the collection of the

data. In this case, the direct observation of the events is very relevant (Bogdan and Bilken, 1994). In our case, the observation was participant since the researcher was also an active participant in the research. According to Vale (2000) the observation is the best techniques to compare what is said with what is done.

Cohen and Manion (1990) emphasize 3 advantages of video recording in the context of educational research: they allow a comprehensive record of behaviours, attitudes, reactions and dialogues, always available for future analysis; they improve the reliability of the study; they allow occurrences to be reviewed repeatedly. In this study, the direct observation and the videos served to allow the narration of the sessions and the main facts that occurred in each, as well as to list the dialogues between students and the researcher.

One of the main instruments in the data collection relied on the files produced by the students when programming the robots. Any change in a program was kept for future analysis by creating consecutive versions of the files. After analyzing the files, we realized that, in the majority cases, these changes are not new blocks of code, but rather small changes in the timing of the actions within the blocks. Normally, the right actions were defined pretty soon in the process, but the exact timing was a process of trial-and-error. Therefore, the right program to implement a given path was reached after a considerable number of attempts, mainly for fine tuning of the times involved.

#### Results

##### a) Building the robots

In the beginning of the first building session, all were very committed and even the harder ones to convince were enthusiastic with the process of building the robots. When they managed to build a “car”, the enthusiasm doubled and they competed to check what the fastest robot was.

##### b) Programming the robots

The students did not show major difficulties in solving the problems in the first list of proposed activities. The challenges that came next put them in a state of anxiety, and this led to some problems when they rushed into solving problems as quickly as they could. Initially, the researcher created a script with activities to provide for an initial contact with the platform.

The students executed some tasks from the script and checked for the results. Then, orally, the researcher proposed some challenges and the students tried to solve it by programming the robot. In this stage, they programmed directly into the robot using the provided interface. Also, students tried to program a few “random” activities and to understand the result.

When the problems got tougher, they started to use the computers and the provided software, downloading the programs into the robot to test them. At this stage the students started to work with the sensors and create programs that would interact with the environment. This new stage is a big step in terms of complexity and it was visible that the students had more difficulties in getting the robot to behave the way they would like it to. Since, the scenarios and the paths for the robots were ready at this time, the students started to program their own robots and trying to solve the specific problems imposed by their tasks.

## 8. Conclusions

One of the motivations for this work is the relative inexistence of studies regarding the application of Robotics as an educational tool, in the context of the first years of teaching (elementary or basic school). This level has been somehow disregarded in these studies, maybe because most of the researchers do not believe that the tool can be applied with such younger children. This project aimed at providing a contribution towards this aim, by successfully conducting a study with students from the 4<sup>th</sup> and 6<sup>th</sup> grades.

The fact that it was possible to reach the main goals of this project, with both groups, given the underlying complexity involving the use of Robotics kits that implied both building and programming the robots for the specific tasks, is in itself a confirmation of the applicability of this tool to children of this age.

In this context, an additional factor to take under consideration is the broad scope of this work in terms of the curricular areas that were involved. In fact, additionally to the traditional areas of Science and Mathematics, this work reached other areas related to Arts and Languages, namely Drama, Plastic Expression, Music and Dance.

By providing a pedagogical context to the new technologies, we integrate in the curriculum a huge amount of available information. The main advantages are: it develops the critical thinking; it develops logical thinking; it increases the interaction and the autonomy in the learning process; and, it raises the interest and motivation for learning.

## 9. References

- [1] Bers, M.; Ponte, I.; Juelich, C.; Viera, A.; Schenker, J. (2002). Teachers as Designers: Integrating Robotics in Early Childhood Education. *Information Technology in Childhood Education Annual*, 123-145.
- [2] Bers, M.; Urrea, C. (2000). Technological prayers: Parents and children working with robotics and values. In A. Druin and J. Hendler (eds) *Robots for kids: Exploring new technologies for learning experiences* (pp. 194-217). New York: Morgan Kaufman.
- [3] Bogdan, R.; Biklen, S. (1994) *Investigação Qualitativa em Educação*. Coleção Ciências da Educação. Porto: Porto Editora
- [4] Chella, M. T. (2002) *Ambiente de Robótica para Aplicações Educacionais com SuperLogo*. Universidade Estadual de Campinas – UNICAMP. Faculdade de Engenharia Elétrica e da Computação – FEEC. Dissertação de mestrado
- [5] CNEB (Currículo Nacional do Ensino Básico; Competências Essenciais (2001). Ministério da Educação. Departamento da Educação Básica
- [6] Cohen, L. Manion, L. (1990) *Métodos de Investigación Educativa*. Madrid: Editorial la Muralla, SA
- [7] Costa, M. F.; Fernandes, J. (2004) Growing up with robots. *Proceedings of Hsci2004*
- [8] Johnson, J. (2003). Children, robotics and education. *Artificial Life & Robotics*, 7(1-2), 16-21
- [9] LEGO Group, *LEGO MINDSTORMS Education NXT Software*, Denmark, LEGO, 2006.
- [10] Merriam, S. (1998). *Case study research in education: A qualitative approach*. San Francisco, CA: Jossey-Bass.
- [11] Papert, S. (2000) What's the big idea? Towards a pedagogy for idea power. *IBM Systems Journal*, 39(3-4).



- [12] Ribeiro, C. (2006). RobôCarochinha: Um Estudo Qualitativo sobre a Robótica Educativa no 1º ciclo do Ensino Básico. Dissertação de Mestrado. Braga: Instituto de Educação e Psicologia da Universidade do Minho
- [13] Roboparty: <http://www.roboparty.org>.
- [14] Silva, J. (2007). Robótica no Ensino da Física. Dissertação de Mestrado. Braga: Escola de Ciências da Universidade do Minho
- [15] Teixeira, J. (2006). Aplicações da Robótica no Ensino Secundário: o Sistema Lego Mindstorms e a Física. Dissertação de Mestrado. Coimbra: Faculdade de Ciências e Tecnologia da Universidade de Coimbra
- [16] Vale, I. (2000). Didáctica da Matemática e Formação Inicial de professores num contexto de Resolução de Problemas e de Materiais Manipuláveis. Universidade de Aveiro.
- [17] Yin, R. K. (1994). Case Study Research – Design and Me
- 
- 

## Study the Leaf Character via Biomaterial Moisture Sensor

P. S. More <sup>1\*</sup>, V.V.Kshirsaga.R<sup>2</sup>, H. R. Khambayat<sup>3</sup>, C.S.Ghuge<sup>3</sup>, A. V. Shelke<sup>3</sup>, A.R.Junghare, A.U.Ubale<sup>1</sup> and S.S. Borwar

<sup>1</sup> Department of Physics, Novel Material research Laboratory, Government Vidarbha Institute of Science and Humanities, Amaravati 444 604 (MS) INDIA

<sup>2</sup> Department of Physics, M. P. S. P. Singh college Bandra (E). Mumbai 400051 INDIA

<sup>3</sup>Department of Physics, Vidya Vardhini's Annasaheb Vartak College Vasai Road (W) 401202 INDIA

<sup>3</sup> Depart. of Physics, Novel Material research Lab,GVISH, Amravati, INDIA  
p\_smore@yahoo.co.in

**Abstract.** The manuscript reports the study of moisture variation in different plant leaf by biomaterial moisture sensor. The sensor verified the typical change in leaf character with respective leaf colour and its different species. The moisture sensing characteristics have been evaluated for different coloured leaves i.e. light green, dark green, yellow and dry leaf for three different plants, namely Hibiscus, Chandani and Rose. The sensing mechanism of such a sensor material is based on the polarization under the action of an external electric field. Furthermore, attempts have been made to correlate weight loss and sensitivity factor (SF) of different leaves of Hibiscus (Dark green leaf SF=130, Light green leaf SF=120, Yellow leaf SF=115, Dry leaf SF=100). Chandani (Dark green leaf SF=130, Light green leaf SF=120, Yellow leaf SF=115, Dry leaf SF=100). Rose (Dark green leaf SF=140, Light green leaf SF=130, Yellow leaf SF=155, Dry leaf SF=100). This study brings out the basic difference in change in colour matters with the moisture concentration in different leaves of different species. Thus, the most important application of the present biomaterial moisture sensor is to verify the moisture concentration and the quality of the foliage.

## Introduction

Like most major agricultural crops and plants developments is negatively impact by moisture

deficit stress while acceptable crops yield enhancements from irrigation are prevalent in arid environments. Leaves moisture plays an important role to maintain the quality of yield in Agriculture field. To maintain the quality of crop by controlled moisture is the major problem crowd in all over world. Bi-colour leaves / bio material moisture study is reported earlier by Yogi et al [1] to check leaf moisture for water scheduling of cash crops.

However, the probability of a response is greater than on a high analysis leaves will provide sufficient nutrients for the best possible yields. This biomaterial moisture sensor is intended for the measurement of moisture content in leaves or other materials with a similar consistency. It has optimized for applications requiring low power consumption in combination with high long-term stability.

A standard 0-1V output facilitates easy interfacing to any readout or logging equipment. It is especially suited for long-term measurements with battery powered cataloguing equipment. This biomaterial moisture sensor is intended as a low-cost alternative where the dynamics of Moisture and water withholding are of major concern and a high absolute accuracy is not required.

A capacitive method is employed which in principle measures the volumetric water content. The calibration curves, however, are dependent on leaf type and moisture concentration. Therefore absolute measurements can be obtained but require calibration by independent methods. The aim of this manuscript is to study the effect of chemo-moisture variation of different coloured leaves of different plants and to study its effect on plant by simple technique.

The sensing mechanism of the device based on the polarization under the action of an external electric field. An attempt has made to correlate dielectric constant ( $\epsilon^k/\epsilon_{ks}$ ) [a parameter that relates the polarization with the change in partial pressure of humidity reactive oil mixture] with number of exposed days. Thus, the most important application of the sensor is to verify the effect of moisture on the quality of crop.

## Experimentation

The biomaterial moisture sensor measures the leaf moisture by electric polarization and converts it to calibrated readings of leaf moisture

suction. The chemo-moisture leaf sensor consists of two parallel plate electrodes implanted in air as reference; the adaptor excites the electrodes with 5 V D.C. potential difference with constant frequency of 1 kHz and measures the electrical potential, which decreases with increasing leaf moisture. The data is then calculated and converted further into different sensor specifications of moisture units.

The purpose was to analysis different plants sample and study the moisture content in the plants and to consult on the procedures for adopting moisture sensitivity measurement techniques in the future research.

## Results and Discussion

The biomaterial moisture sensor characterization are further studied for different plants leaves and with its change in colour

### Sensor study

The sensor sensitivity studied for the different leaf samples of different plants. The sensitivity factor defined as the percentage change in ratio of change in capacitance of samples with respective air i.e.  $SF = C_s/C_a * 100$  for Hibiscus, Rose and Chandani leaf respectively.

#### (I) Sensitivity variation with exposed number of days for Hibiscus leaf

From, figure 1, it can be seen that, the sensitivity factor of Hibiscus light green leaf and dark green leaf sample for cycle 1,2,3 decreases from day 1<sup>st</sup> to day 7<sup>th</sup>. The day 7<sup>th</sup> onward, the sensitivity factor almost remains constant. Similarly, it also depicts that for all the 3 cycles, sensitivity of Hibiscus yellow leaf samples decreases from day 1<sup>st</sup> to day 8<sup>th</sup> remains constant further.

From the above fig., it is clear that, the sensitivity factor of Hibiscus light green leaf ( $L_1C_1LG$ ) and dark green leaf 1 ( $L_1C_1DG$ ) sample for cycle 1, cycle2, cycle3 decreases rapidly from 1<sup>st</sup> day to the 3<sup>rd</sup> day. It means moisture level decreases. 3<sup>rd</sup> day onwards it decreases slowly up to 7<sup>th</sup> day. 7<sup>th</sup> day onward it almost remains constant, Figure depicts that for all the 3 cycles, sensitivity i.e. the ratio of capacitance of Hibiscus yellow leaf no. 1 ( $L_1C_1Y$ ) decreases rapidly from 1<sup>st</sup> day to the 6<sup>th</sup> day. It means moisture level of leaf decreases. 6<sup>th</sup>

day onwards it decreases slowly up to 8<sup>th</sup> day. 8<sup>th</sup> day onward it almost remains constant. Fig also depicts that for all the 3 cycles, sensitivity of Hibiscus dry leaf (L<sub>1</sub>C<sub>1</sub>D) no. 1 Almost remains constant; it means it does not contain moisture at all

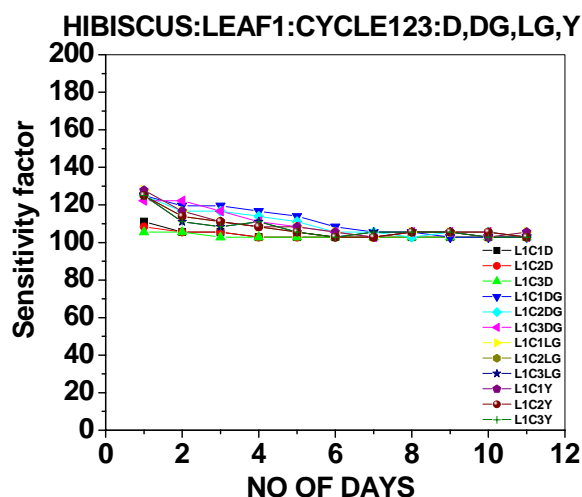


Figure 1: Variation of Sensitivity Factor w.r.t. Number of Days (for L- leaf, C-cycle, D-dry, LG- light green, DG- dark green, Y- yellow)

(II) Sensitivity Variation with Exposed Number of Days for Chandani

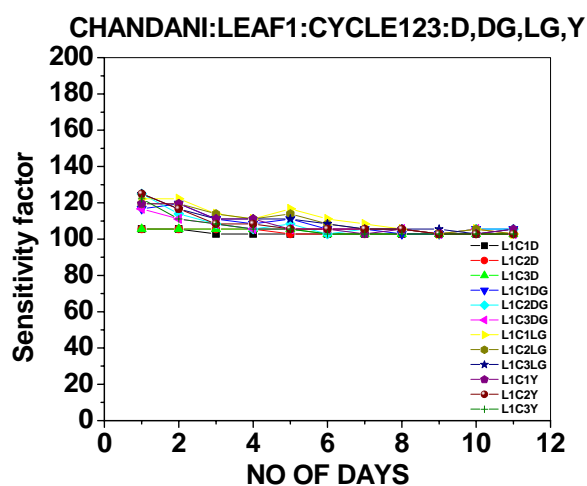


Figure 2: Variation of Sensitivity Factor w.r.t. Number of Days (for L- leaf, C-cycle, D-dry, LG- light green, DG- dark green, Y- yellow)

From the above figure 2, it is clear that, the sensitivity factor of Chandani light green and dark green leaf of sample for cycle 1, 2, 3 decreases from day 1<sup>st</sup> to day 9. Day 9 onward it almost remains constant. Figure 2 also depicts that for all the 3 cycles, sensitivity of Chandani yellow leaf no. 1, decreases rapidly from day 1<sup>st</sup>

to day 6. It is clear that the moisture level of the leaf decreases. 6<sup>th</sup> day onwards it almost remains constant. Fig also depicts that for all the 3 cycles, sensitivity of Chandani dry leaf no. 1, almost remains constant ; it means it does not contain moisture at all.

(III) Sensitivity Variation with Exposed Number of Days for Rose leaf

From the fig. 3, it is clear that, the sensitivity factor of Rose light green leaf 1 sample for cycle 1, 2, 3 decreases from day 1 to day 9. From day 9 onward it almost remains constant, it can also be seen that for all the 3 cycles, sensitivity of dark green leaf decreases rapidly from day 1<sup>st</sup> to day 8. It indicates that the moisture level of all the leaves decreases. Day 8 onwards it almost remains constant.

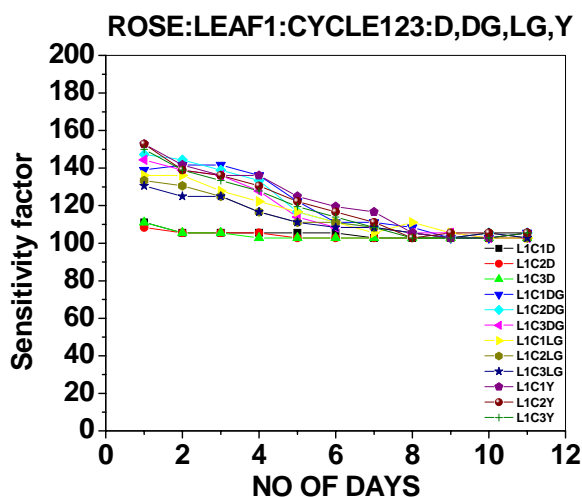


Figure 3: Variation of Sensitivity Factor w.r.t. Number of Days (Chandani Pale Green leaf) (for L- leaf, C-cycle, D-dry, LG- light green, DG- dark green, Y- yellow)

This topic deals with the discussion of all the results presented above on the basis of reported theories. The discussion based on the results obtained as a leaf moisture sensor for detection of moisture level in the leaf.

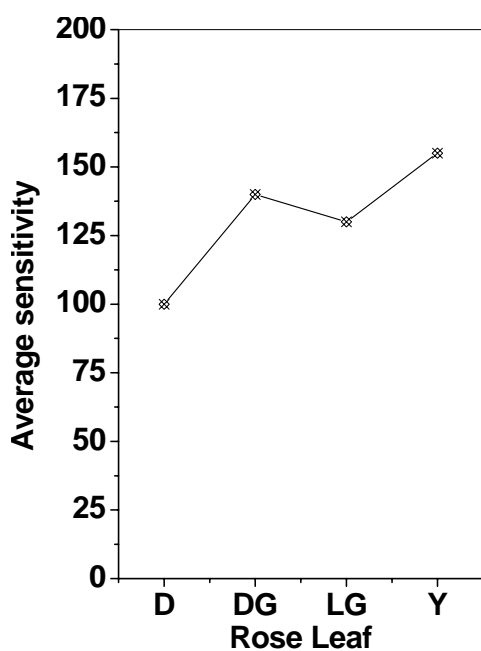
From the above figure 3, it is clear that, the sensitivity factor of Rose light green leaf (L<sub>1</sub>C<sub>1</sub>LG) 1 sample for cycle 1, cycle2, cycle3 decreases rapidly from 1<sup>st</sup> day to the 5<sup>th</sup> day. And 5<sup>th</sup> day onwards it decreases slowly up to 9<sup>th</sup> day. 9<sup>th</sup> day onward it almost remains constant, Fig also depicts that for all the 3 cycles, sensitivity of Rose dark green leaf (L<sub>1</sub>C<sub>1</sub>DG) no. 1, decreases rapidly from 1<sup>st</sup> day to the 8<sup>th</sup> day. It means moisture level of all the leaves decreases. 8<sup>th</sup> day

onwards it almost remains constant. Fig depicts that for all the 3 cycles, sensitivity of Rose yellow leaf (L<sub>1</sub>C<sub>1</sub>Y) no. 1, decreases rapidly from 1<sup>st</sup> day to the 8<sup>th</sup> day. It means moisture level of all the leaves decreases. 8<sup>th</sup> day onwards it almost remains constant. Fig depicts that for all the 3 cycles, sensitivity of Rose dry leaf (L<sub>1</sub>C<sub>1</sub>D) no. 1 decreases slowly from day 1<sup>st</sup> to day 2<sup>nd</sup>. Second, onwards it almost remains constant.

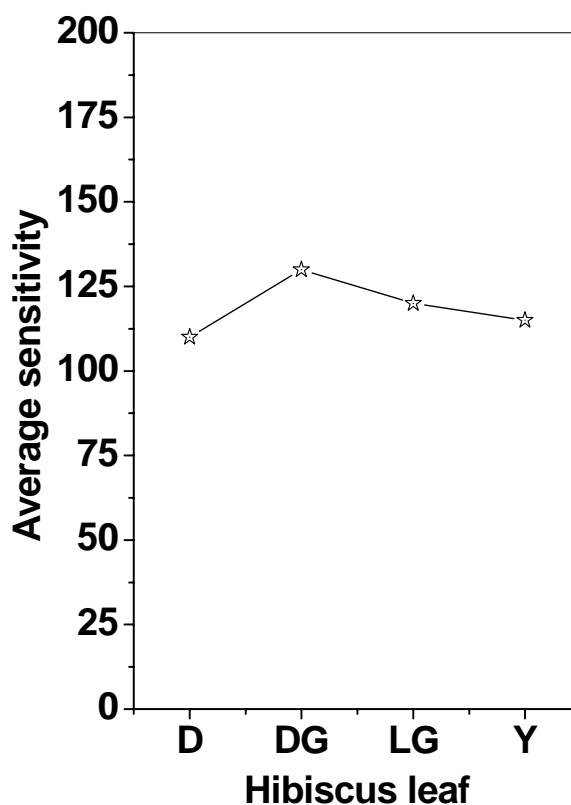
#### (IV) Optimization of Sensitivity of Rose, Hibiscus and Chandani Leaf

From figure 4 (a), we observed that, the yellow leaf of Rose shows more sensitivity (SF=155) as compared to light green (SF=130) and dark green leaves (SF=140) However, the moisture level of yellow leaf is comparatively more. Dry leaf of Rose shows least sensitivity (SF=100) in the entire category.

From figure 4 (b), we observed that, the dark green leaf of Hibiscus shows more sensitivity (SF= 130) as compared to Yellow leaf (SF=115) and light green (SF= 120) as the moisture level of Green leaf is more which indicates that the amount of moisture concentration is more. Similarly the dry leaf of Rose shows least sensitivity (SF=100).



(a)



(b)

Figure4 : Bar diagram of average sensitivity according to category of leaf Rose leaf and Hibiscus leaf, Here D- Dry, DG -Dark green, LG- Light green, Y- stands for yellow,

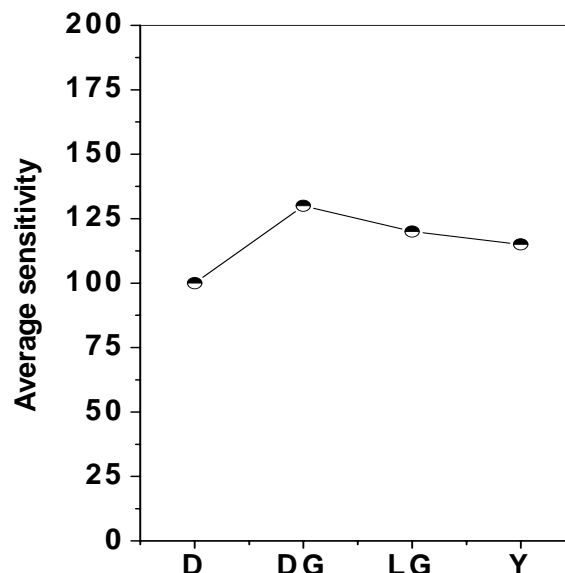


Figure 4 (c): The average sensitivity according to category of leaf. (Chandani leaf) Here D- Dry, DG -Dark green, LG- Light green, Y- stands for yellow

From figure 4 (c), we observed that, the sensitivity of dark green is highest (SF = 130) in

all the categories and sensitivity of dry is lowest (SF=100). It depicts that the dark green leaves contain more moisture as compared to other categories and a dry leaf contains less moisture concentration.

### Conclusion

One can conclude that fabrication of moisture sensor and its application for moisture sensor technique is use for leaf moisture analysis.

- i. Sensitivity of the Rose leaf (yellow leaf) is found more moisture concentration.
- ii. Sensitivity of Dry leaf (Rose, Hibiscus and Chandani leaf) is found lowest concentration.
- iii. In all different category of leaf it is observe that the moisture contain in all the leafs are different.

### References

- [1] R. A. Yogi, Gangal S. A. ,Aiyer R. C. and Karekar R. N. Sensors “Study of bi-coloured leaves by microwave micro strip moisture sensor” S and A (B) 55 (1999) 186- 190.
- [2] R. A. Yogi, Gangal S. A. ,Aiyer R. C. and Karekar R. N “Microwave ring resonator as a novel bio-material moisture sensor” S and A (B) 50(1998) 38-44.
- [3] Zhou zhi-Gang, ZHAO Gang, WEI Ming and Zhong-Tai. “Temperature Humidity-gas-multifunctional sensitive ceramics” Sensors and Actuators 19 (1989) 71-81
- [4] Jacob Fraden “AIP Handbook of Modern Sensors: Physics, Designs and Application” American institute of Physics, 335 East 45<sup>th</sup> street New York.
- [5] Mosley P.T, “Material and mechanism in Semi conducting gas sensor technology: System and application (gas sensor) IOP publishing (1990) 89-99.
- [6] P. T. Moseley “Solid state gas sensor” Meas. Sci. Technology 8 (1997) 223-237
- [7] Tun Tschu Chang “Effect of soil moisture content on the survival of Ganoderma species and other wood-inhabiting fungi. Plant Dis” Agronomy Journal Volume (87) 1201-1204.
- [8] Jagadish Timsin, Upendra Singh, Mohammed Badaruddin, and Craig Meisner, Cultivar, Nitrogen, and Moisture Effects on a Rice–Wheat Sequence: Experimentation and

Simulation SOILS Volume 90 March–April 1998 Number 2

- [9] M. Tejada, C. Benitez, and J. L. Gonzalez Effects of Application of Two Organomineral Fertilizers on Nutrient Leaching Losses and Wheat Crop American Society of Agronomy 97:960–967 (2005).
- 
-

## Science Fairs in Non-Disciplinary Curricular Areas

Z Esteves<sup>1</sup> and M.F.M. Costa<sup>2</sup>

<sup>1</sup>Externato Maria Auxiliadora. Avenida S.  
João Bosco, 365, 4900-896 Viana do  
Castelo, PORTUGAL

<sup>2</sup>Departamento de Física, Universidade do  
Minho, Campus de Gualtar, 4710-057 Braga,  
PORTUGAL

zita.esteves@gmail.com,  
mfcosta@fisica.uminho.pt

**Abstract.** During the school year of 2008 – 2009 it was organized the third edition of the science fair of Externato Maria Auxiliadora, in Viana do Castelo, Portugal. This fair involved students from the 5<sup>th</sup> grade to the 9<sup>th</sup> grade (ages between 10 and 15 years old).

On previous years students had the opportunity to work, at school, with the responsible teachers during lunch time. On this edition, students had also the opportunity to work, in some occasions, in their projects in “Área de Projecto” and in the Science Club.

The effort of the science teachers that organized this event for the third time was reduced by the involvement of these non-disciplinary areas. This fact, associated to the experience that students acquire along these years, by participating or seeing the projects of others colleagues originate a science fair with good projects and the success was even larger. This event is already visited by family and friends of our students, but we hope that next year, this work will be presented to a larger community.

**Keywords:** basic schools, informal learning, science fairs, science project classes.

### 1. Introduction

During the XX century many changes were implemented on the curriculum of the Portuguese Schools to construct a better educational system [1] and decrease the school abandon. One of the last changes was the introduction of “Área de Projecto” that started an experimental way in some schools in 1998 [2].

“Área de Projecto” is a curricular area, non disciplinary with a curriculum conception more

flexible and autonomous to the school and teachers [1], and that works with an interdisciplinary method [2,3,4,5]. The curriculum of this area is discussed between teachers and students, taking into account the social and economic situation of the students, the reality that surrounded them [2,3,4] and the partnerships that they can form [1,4].

The major objective on this curricular area is the development of projects where the creativity, the investigation techniques, the text production and the scientific and social knowledge is stimulated. [1,2] All of this will contribute to a better school and, in the future, be responsible for helping the professional orientation of students [1,2,3,4], promoting their better comprehension of the world [1,3,4].

This curricular area should be promote a relation between school and general community, like the family but also companies and others institution. Students and teachers improve and develop not only scientific but also personal and social capabilities, since this is an opportunity for students meet and reflect about social, economic, technological, scientific, artistic, ... issues [3].

Teachers are responsible for the orientation of the project development but they also can ask for help to others teachers of the class [2,3].

The projects developed should respect a scientific method, promote the debate of ideas [2,3], based on experiments associated to systematic observation, formulation of hypothesis, testing them and finally the analyze, interpretation and explanation of facts and phenomenon of the real world [1,3]. Teachers from Área de Projecto should be responsible to give the opportunity of students to develop a project, therefore, they have to access to internet, movies, books, experimental and non experimental reports, videos...[3]

Science fairs are a way of students to develop scientific projects and learn how to make science. The science fairs can involve actively students during this learning process and the results are scientific productions that can be presented to others [6,7].

With this work we pretend to show how one extra curricular activity like a science fair, that students like and that can be developed with in this non-disciplinary area. Therefore, we have the opportunity to stimulate students to science without over charging of their free time.

It is relevant to inform that the steps presented here never limited students from working at home or in their spare time.

## 2. Development of the project

The realization of the 3<sup>rd</sup> edition of the science fair was announced to students and parents in the beginning of the year on a general meeting. However, during the first two school weeks we have remembered/explained the rules and principles of a Science Fair with more detail and present some important dates related with this event.

We announced to students that some time from “Área de Projecto” will be available to them for the development of their work. To students that participate on the Science Club, it will be also given the opportunity to develop their work in that context. Otherwise, students should work at home and could get help from the teachers of disciplinary areas at any time they need.

It is important to say that the involvement at “Área de Projecto” was not mandatory. The teachers evaluate the work developed by this students, but attributed other kind of projects for students that didn't want to participate in the science fair.

The involvement in this non-curricular discipline was important for the students since they didn't had to work on their free time, giving them the opportunity to research, plan and experiment and make their own conclusions during these classes. It was also a great help to science teachers that organize the science fair since they have more time to plan the science fair and to supervise the students projects.

At the beginning of the year, it was explained to “Área de Projecto” teachers what should be done to successfully help the students in their science fair projects. During the year some meetings were made to discuss with those teachers the evolution of the student's projects. It was explained to them that during the first period students should be able to research from a subject of their interest and form, by themselves, groups with other students with the same kind of project. Those teachers should help students to question about their research topic and help them in the search for solving those same questions. During those “Area de Projecto” classes students had internet access and could search on the

school library. They were also invited to discuss their ideas with all kind of people, from family to friends or professionals from that subject. After the students decision about the workgroup and the theme, teachers helped them writing a small report, with the title, the material and a brief explanation about the subject they propose to study, in order to be analyzed and discussed with them.

The only problem faced was the fact that the “Área de Projecto” teachers were not from a science field and couldn't help students directly with their scientific doubts. But this problem was solved, since the students could use hours from the science club or at lunch time to discuss with their science teachers.

After analyzing all chosen projects we've discuss with all groups the viability of that same projects. Some of them were denied due to dangerous material or difficult to find, or if that same project do not have any scientific interest. Those students had the opportunity to reformulate the projects and many of them did it.

During the 2<sup>nd</sup> period students continued to develop the projects at school and at home. They still had the opportunity to work on „Area de Projecto“, where they could also laboratory facilities.

The evaluation of the students that participate in the Science Fair on “Área de Projecto” was made according to the general parameters already proposed for this school subject as:

- ✓ The commitment on the research and development of the theme;
- ✓ Autonomy;
- ✓ Teamwork;
- ✓ Problem solving abilities,
- ✓ The final product quality (this parameter was discuss between science teachers and “Area de Projecto” teachers);
- ✓ The science fair presentation.

On the beginning of the 3<sup>rd</sup> period the fair was presented during an afternoon and was open to the entire school community and to all people that wanted to see.

The evaluation of the projects was made taking into account some aspects like:

- ✓ The evolution of the work;
- ✓ The initial report taking into account scientific issues;
- ✓ The originality on the choice of the theme;
- ✓ The respect of deadlines;

✓ The presentation at the science fair.

Taking into account the number of participants, it was decided to select the 3 best projects from the 5<sup>th</sup> and the 6<sup>th</sup> grades, and also the 3 best projects from the 7<sup>th</sup> to the 9<sup>th</sup> grades. This division was made by ages and because of the limited scientific knowledge in physics or chemistry. To all the others students that respect the parameters proposed, it was attributed an honourable mention.

### 3. Results and discussion

The science fair is organized at Externato Maria Auxiliadora since the school year of 2006/2007 and analysing the evolution of the students participation it is possible to conclude that the number of participants it rising as we can see on Figure 1. On the first edition 42,9% of the students participates (that edition were only for students from 7<sup>th</sup> to 9<sup>th</sup> grades); on the second edition 65,6% of the students participates and on the third edition it was 77,9%.

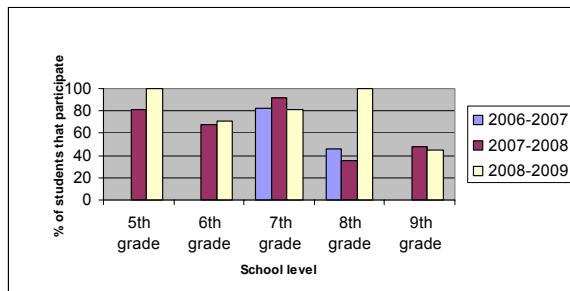


Figure 1 - Evolution of the participation of the students at the science fair

The major evolution verified this year was on the 5<sup>th</sup> and 8<sup>th</sup> grades.

The participation of students from the 9<sup>th</sup> grade is still limited. The reason appointed from students is that they had too much work at school due to the exams in the end of the year. However, with the largest participation from 8<sup>th</sup> grade students and the introduction of this activity in “Area de Projecto”, we hope that the tendency of “older” students of not participating at the fair changes next year.

The highest enthusiasm from the youngest students was evident on the excellent projects they present, even better that form the oldest students.

Analysing the decisions from the jury, we can conclude that 71,8% (28 of 39) of the projects presented at the fair respected all the parameters.

Along these years it was evident that students preferred to work in groups. However, the tendency of establish groups of four elements (number limit accepted) is decreasing and the individual projects are increasing. Working in pairs is a good choice if students have the same enthusiasm in the project and share responsibility during the development and the presentation of the same. Students start to understand that fact. For this reason they need to start by selecting the subject and not the group. It was also told to “Área de Projecto” teachers to remember the students about that fact.

One interesting feature of this year fair was the inclusion of what we call 4 non experimental projects. These projects didn't have an experimental base that permits to explain or test any factor. They simply explain how some things work. As an example we have the project of two students from the 7<sup>th</sup> grade that explained the car clutch system, as we can see on Figure 2. Curiously, this kind of project made a great success between students.



Figure 2 - The peaces of the break system of a car

### 4. Conclusions

These three years of a science fair organization at Externato Maria Auxiliadora were very helpful, since the experience of working with this project in the same school, with some of the same students allowed us to conclude that a large number of students already understand the meaning of a science fair and how they should develop and present their project.

The fact that the science fair was announced to parents increased the number of visitants and we could clearly see a major involvement from parents and friends during the development of the projects. As an example, we gave the first



prize to a group of four students of the 5<sup>th</sup> grade that explained how the telegraph works, as we can see on Figure 3. In this case, parents helped the students on the construction of the telegraph, since it was necessary to use some materials that could be dangerous to them, and also helped them in their presentation.



Figure 3 - Students explaining the Telegraph

It was curious to see that these four students of the 5<sup>th</sup> grade made a complete study of the history and operation of this instrument.

The only problem that we appointed this year was the fact that, due to the great number of projects (39) and the limited time (from 14h00 to 17h00), didn't allowed us to have a clear and calm view of all the projects presentations.

## 5. Future work

During the next school year of 2009/2010 we will continue to organize the fourth edition of the fair. The projects will continue to be developed in the same way and we will continue implement this project on the "Área de Projecto" curricular area.

To help on the construction of the materials and posters, the teachers of Visual and Technological Education (EVT) will include the projects of the science fair on their subject.

The fair will be presented during the third period, and will be made on a Saturday and during all day. The event will take place this time on the city of Viana do Castelo downtown centre. We expect that these new features of the event will make possible for more people to see the work of these young scientists.

## 6. References

- [1] Despacho n.º 19308/2008 (Princípios orientadores das Áreas Curriculares Não Disciplinares). Ministério da Educação. 21 de Julho de 2008.
  - [2] Graça, E. Bibliotecas Escolares e Área de Projecto. Dissertação de Mestrado (2005), p. 107-151. Universidade do Minho, Braga, Portugal.
  - [3] Orientações de Área de Projecto dos Cursos Científico-Humanísticos e Projecto Tecnológico dos Cursos Tecnológicos. Ministério da Educação. (2006).
- 
-

## Advanced Multi-layer Model for Information Security in e-Governance

S.A. Chaudhari  
Veer Narmad South Gujarat University,  
Surat, INDIA  
shailesh\_mca@yahoo.com

**Abstract.** In this paper, we have discussed a layered model for identifying and specifying threats which affect e-Governance environments. The purpose is to establish a layer which may be used in future in constructing a comprehensive model which will consist of multiple layers that complement each other. The key goal of the scope of work of this paper is how to position the main security aspects in a single model to represent security architecture with multiple layers that complement each other in order to reach a better level of security for any organisation. The paper puts across the key issues and challenges in assessing threats in e-Governance projects based on categorisation of threats and propose a layered model.

**Keywords:** e-Governance, Threat Analysis, Multi-layer Model, Security Technologies, Competencies.

### I. Introduction

The evolution of e-Governance started with governments putting their information on portals. e-Governance is not only providing information directly to citizens, businesses and other governments; they are also interacting with citizens in terms of understanding licensing application, taxes, etc. Information security is major concern involved in implementing e-Governance projects [1]. Digital watermarking can be utilized for authentication of data. It is effective technique for protecting intellectual property (IP) rights by embedding information in digital data [2][6]. Information security presents lot of

challenges and concerns to governmental and commercial organizations. Models are used as the best method for illustrating new concepts or architectures [3]. Many models were analyzed to find out how comprehensive they are. The objective of the new security model is to assist in visualizing the combination of different layers of security in order to come up with a mechanism of enhancing the security level of any e-enabled organization but specifically in using the e-Governances as the case study. We discuss the concept of multi threats for a single e-service, the needs of having a model addressing these threats and an application of this concept over the e-services. This multi-threat concept can be considered as the foundation of the need of a multi-layer model. Many international standards exist in the field of IT security. A knowledge base comprising a threat countermeasure model based on international standards (ISO/IEC 15408, 15446, 19791, 13335 and 17799 standards) for identifying and specifying threats which affect IT environments [4]. Information Security governance has become an established and recognized component of Corporate Governance, and specifically Information Technology governance [5].

### A. What is e-Governance?

e-Governance however is not really the use of IT in governance but is a tool to ensure good governance. e-Governance does not mean proliferation of computers and accessories; it is basically a political decision which calls for discipline, attitudinal change in officers and employees.

The governance has various departments like Agriculture, Industries, Health, Education, Social Welfare, Employment, Taxation, Finance, Pensions, etc.

### B. What is e-Governance?

To design an e-Governance framework, security has become a key issue that need to be addressed. Security is critical in e-

Governance to safeguard the confidentiality of transactions and information on the internet. Government documents and other important material such as birth and death registration, motor vehicle license, land records, all of which have to be protected from unauthorized users in case of e-Governance projects. Hence, security is critical for their successful implementation.

### **C. Where securing e-Governance?**

Security measures are required wherever authenticity, validity and legal rights of digital content have to be protected from repudiation. All digital content in form of applications that need protection from tampering, vandalism, decay and accident need security. The role of information security is vital in every application, which collects or store data, interacts with an outsider, carries some confidential information and other applications online and the best example of having most of such qualities and requirements are e-Governance projects.

In some online application we need transition of money, such as banking, shopping, gambling and gaming. With IT Act, transactions on the internet have got legal validity. This allows users to pay their bills for utilities on the web.

### **II.A multi-layer approach for threats classification and analysis on e-governance services**

Security requirements for e-Governance services as analysis are:

- System Availability
- Performance
- Management of privileges
- Authentication
- Logging
- Confidentiality
- Integrity
- Non-Repudiation
- Secure Storage

Many cases are stressing on the need of applying the right technologies in order to protect the e-Governance information resources. Security technologies will play a major role in protecting and mitigating such risks. The selection of the appropriate technology is also crucial to the security architecture of the organization. The objective is to turn the threat auditing and analysis process into a detailed 360 degrees analytical process which addresses all the threats related to an e-service. An effective information security programme must consider both IT and non IT related issues. The new threats analysis method can be considered as a tool to think about the threats of a new e-service and a method which can be used by security officers and practitioners to highlight a risk and manage its effect.

### **A. Threats and its impact on online services**

An e-service represents a way to allow customers, citizens, and corporations to interact with the service provider over the Internet using a backend support infrastructure of information assets and resources. Threats on the e-services are the same threats of any IT system and can be categorized as:

- Natural threats described by terms such as ‘Act of God’ or ‘force majeure’ that include for example, unforeseen events like a flood or an earthquake.
- Accidental threats caused by factors such as missing out in a plan or a procedure.
- Intentional threats caused directly or indirectly by staff who are involved in operation like the deletion of data with intent to transfer funds.

The categorization only simplifies the analysis process of the different facets of the threat. Conducting a detailed analysis on the total number of threats of an e-service going through different process, a set of threats (T) will need to be considered in addition to other threats which may be identified during the analysis process. Knowing the source of

the threat will assist in developing the appropriate security operational strategy and increase the probability of the service availability.

The dimension of intention is critical to the operation of information technology and the supporting infrastructure to the online service in general. The e-service includes supporting technology, integrated processes, and support staff. The security threats on any of the key elements of the online service will have a direct impact on the service and its users. The growth of threats continues along with the wide spread of the Internet. Considering the fact that e-services are generated from business applications and knowing that there are multiple threats for each single application, which justifies the need of multiple layers security model. The applications threats can be listed as under:

- Unknown Outsider Attack
- User Fraud
- Insider Attack
- Privileged Insider Attack
- False Identity
- Impersonation
- Unauthorized Disclosure
- Revoked rights
- Theft Access Tokens
- Duplication of Access Tokens
- Denial of Service Attacks
- Misinformation and Propaganda
- Breach of Anonymity
- Breach of Accountability
- Failure to Recover Business Information
- Theft on Monetary values

The above threats represent threats on the technological side of application management. Here we consider that security threats are built up and constructed in different layers or levels for any e-service. A threat is a combination of the capability of the perpetrator and the intention of his action as indicated in Equation 1. A capability element is directly related to the level of competency of the IT staff or the security

officers responsible for the infrastructure (Equation 2).

$$\text{Threat} = \text{Capability} + \text{Intent} \dots \dots \dots (1)$$

$$\text{Capability} = \text{Access} + \text{Skill} \dots \dots \dots (2)$$

## B. Towards a complete model for e-services security

Most of the literature emphasizes the challenges of e-Governance through the infrastructure protection alone. The infrastructure protection will alleviate some of the risks to e-services, but it will not be sufficient to counter all threats. The security policies and procedures might not be common for all the e-services offered and the supporting staff might have different levels of competencies. The approach of analysing the various threats of a single e-service discussed in this paper is shown in Fig. 1. The e-services can be provided by a single application or multiple business applications. The process of launching an e-service might have a high dependency on the reliability of the technology, the need of developing special security policies related to the e-service, and the availability of competent support staff and the operational procedures. The following are the essential security levels required for e-services:

- A secure technical infrastructure
- Security policy related to the e-service
- Competent security team and officer
- Secure operational and management procedures
- A systematic method of taking a decision

## C. Evaluating the total threat

The total threat value may be considered as sum of probability of the threat in each level for an e-service. Safeguards have to be set in each level in order to reduce the threats associated with it. The threat value of each level is:  $T(i) = T1 + T2 + T3 + T4, \dots Tn$ .

**Level of Risk**

$$= \frac{((T(i) * Vulnerability)/Countermeasure) * Impact$$

**D. Threats Analysis**

The approach of analysing the various threats of a single e-service adopted here is explained in Table 1. By applying this comprehensive method of looking at all relevant threats, accuracy on the real impact of the e-service threat can be achieved and the countermeasure(s) can be applied. The output from this approach will assist the e-service to be launched with confidence and increase the trust and usability of the users whether they are government organisations or citizens.

Y-Axis Security Levels required	Decision (TD)	1	2	3	4	5			
	Ops & Mgmt	1	2	3	4	5			
	Competency (TC)	1	2	3	4	5	6	7	8
	Policies (TP)	1	2	3	4	5	6	7	8
	Technology (TT)	1	2	3	4	5			
X-Axis Threats on each Level									

**Fig.1 Threats Analysis**

		•
		•
	•	•
		•
	•	•

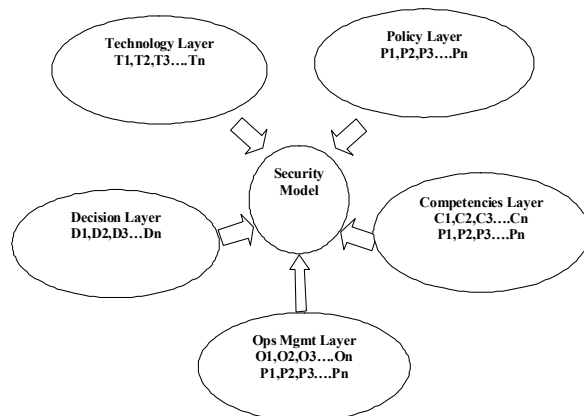
**TABLE I Application of multi-threats concept on e-services**

Since most of the e-services require more than a single step to launch, the approach discussed in this section and illustrated in Table I can be applicable to government authority and its affiliates offering similar e-services. The method of analysis is not limited to e-Governance services only. A column of numeric threats' values can be added if a quantified analysis is needed to give each e-service a value from threats perspective. The threats analysis can be based on what's available for the e-service and

what's missing in order to make it more secure. In addition, the above table can be used as a checklist for each e-service and can determine the priority of launch for each e-service.

**III. The layers of e-governance security model**

Having more than one dimension or layer of any model gives the model a robust structure and a better success rate in preventing organisations from various categories of threats related to a single or multiple e-services. Each layer will alleviate group of threats related to an e-service. The technology layer for example will address all the technological threats while the policy and competency layers will address the threats on an e-service related to the human aspect.

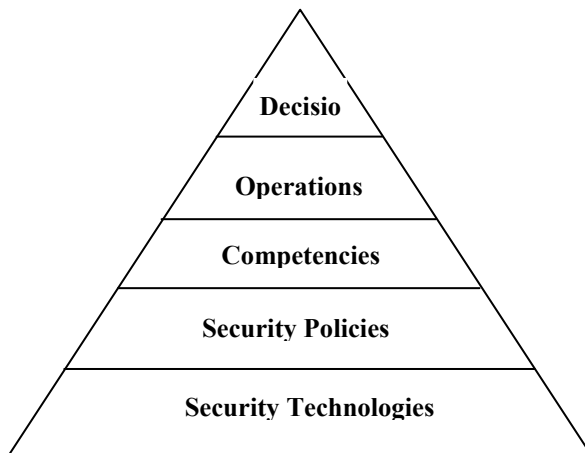


**Fig.2. The different five layers building the new security model**

There are five areas that contribute in building strong security architecture and system (Fig.2). It can be noticed that each area is a broad concept of the information security field and can be broken to smaller subsets which collectively contribute to the positive effect of the security programme of any organization.

The idea of the new model is to come up with a comprehensive method in reviewing the security needs and requirements for any e-enabled organization in order to allow or not to allow the interchange of information with other e-organizations. To ease the visualization from a non technical user point

of view, the conceptual model is expressed in a pyramid representation as illustrated in Fig.3. The layers are constructed from bottom to top based on the importance of the layers, the frequency of their implementation in organizations, and how they complement each other.



**Fig.3 A Model describing multiple Layers of Security System**

The structure of the model with the five main aspects of security (technology, policy, competency, operation and management, decision factors) is applicable to any organization with a possibility of changing the sub layers based on the security trends in the market and the organization needs.

#### **A. The security technologies layer**

The approach of providing an extensive knowledge on security technologies can be part of the awareness strategy but not enough to justify the inclusion of the security technologies in the organization. A brief description is provided on the need of these technologies in any organization and how to use them. As part of the study work, all security technologies known in the security field can be considered as the initial stage. A categorization can be made to combine the security technologies into groups where each group represents a security measure. For example, there are many types of firewalls available in the market. Some of them are operating in the application layer while

others are in the network and transport layers of the networking OSI seven layers (physical, data link, network, transport, session, presentation, application). Regardless of the modus operandi of the firewalls, they all can be categorized as logical access control which can represent a single sub layer of the new model.

#### **B. Security policies layer**

Many security experts believe that system security, product security, community security, and corporate information security policies are always the main concern of most of the security policies developers. The policy pillar can vary from one to as many policies are required for the organization. The audience pillar is usually limited to five or six categories. Using this analogy, limited number of policies may be required for e-governances. These policies might increase due to new needs from e-governances or an occurrence to a new threat. The model will still hold as the idea is to have the right combination of policies with the other layers in the model and can hold irrespective of the number of the policies. The policies selected to form the layer are password management, log-in process, logs handling, computer viruses, intellectual property rights, data privacy, privilege control, data confidentiality, data integrity, Internet connectivity, administrative policies, encryption policies, HR security policies, third party policies, physical security policies, and operation security policies.

#### **C. Security competencies layer**

Due to the proliferation of the Internet and the usage of the citizens of the government wide e-services, government departments must invest on the human capital of the information security departments. Having a competent security team within the organization will solidify the security infrastructure. Whether the organization decides to extend the awareness

programme to the users or to limit it to its staff, the information security awareness programme should cover the baseline topics of the security knowledge such as security operation and management, security architecture and development, ethical hacking, security policies development, computer forensics, cryptography, security programming, law and regulations, security implementation and configuration, and security analysis. The competencies listed above will assist the government department enhancing the control of security and narrow the gap of the knowledge between the different government security departments. It will contribute in elevating the trust on the security programmes between the government departments and will increase the usability of the e-services by the citizens due to the strong confidence in the security level of the government departments.

#### **D. Security operations and management layer**

The National Institute of Standards and Technology (NIST) categorized the security controls into three categories; technical, operational, and management: Technical controls as the security products and processes an organization is placing to protect the IT infrastructure. The operational controls are the mechanisms which will ensure the proper security operation and prevent any operational misconduct. The management controls are related to the usage policies management and the disaster recovery tasks management. Security is about vigilant monitoring and management of critical assets and information resources. Management and operational tools are a must to have in order to enable the security practitioner to perform the task and achieve the best objectives. The most important aspect of this layer is how the organization runs its operation. The operational policies and procedures are the rules and regulations where the security operational staff will follow in performing the tasks expected from

them. The concept of protection alone will not serve the organization to reach the accepted security level. It has to be protection, detection and response together in order to reach the maximum security benefits.

#### **E. Security Decision layer**

Reaching the right decision for launching or not launching an e-service will have a direct impact on the success or failure of the e-service. Taking one direction or another can affect the overall model in selecting policies, technologies and hiring the right staff to run the security programme. Insufficient budget is the number-one obstacle to effective information security, followed closely by “resources priorities”.

Network and security administrators use fear, uncertainty and denial (FUD) to justify the need of security. The cost verses the need of security; the awareness of technologies verses the availability of these technologies and above all, the physiological effect of FUD over the decision. Each factor has a direct or indirect effect the other sub factors in the same layer as well as the other sub factors in other layers of the model. The cost of security technologies is a good illustrative point to the impact of the decision layer on other layers of the security programme. Considering the cost constraints of any organization, having the best technology, right competency, end-to-end operation and management infrastructure, and the right security policies will be evaluated thoroughly.

#### **IV. Conclusion**

The concept of having x number of layers come up with a better level of security is what we considers as “new model” and a “new approach”. This can be continued to find out the sub layers of each layer needed in any information security system or programme. The purpose of the discussion in this paper is to establish any sub layer which

may be used in future in constructing a comprehensive model which will consist of multiple layers that complement each other. Moreover, number of layers might change based on other studies or literature reviews.

## V. References

- [1] "Information Security", CSI communications, Computer Society of India, 2007.
  - [2] "Role of Digital Watermark in e-governance and e-commerce" Mrs. S.S.Sherekar, Dr. V.M.Thakare, Dr. Sanjeev Jain, IJCSNS International Journal of Computer Science and Network Security, VOL.8 No.1, January 2008
  - [3] "e-Government Strategy Framework Policy and Guidelines", office of the e-Envoy, UK, 2002.
  - [4] "Study on a Threat-Countermeasure Model Based on International Standard Information" Guillermo Horacio RAMIREZ CACERES and Yoshimi TESHIGAWARA Graduate School of Engineering, Soka University
  - [5] "Information Security governance: COBIT or ISO 17799 or both?", Basie von Solms, Academy for Information Technology, University of Johannesburg, Johannesburg, South Africa, Computers & Security (2005) 24, 99e104.
  - [6] "Digital water marking for secure e-Government Framework", D K Sharma, V. Pathak & G. P. Sahu, CSI India, 2007.
- 
- 

## Derive to Retrieve: Bioinformatics

M.J. Vibhuti, P.S. Bhavisha, B.M. Viralkumar, M.B. Yogesh and S.T. Vrinda  
BIT<sup>virtual</sup>, The Virtual Institute of bioinformatics, Centre for Advanced Studies in Plant Biotechnology and Genetics  
Engineering, Department of Bioscience,  
Saurashtra University,  
Rajkot – 360 005 INDIA  
vibhuti115@gmail.com

**Abstract.** The field of bioinformatics has emerged at the intersection of other fields of science like the Biology, Genetics, Statistics, and Mathematics and Computational sciences. This new realm of science has been a boon as it minimizes the time, cost and labour of designing the experiments in the lab by quick compilation of the data. The applications of Bioinformatics are diverse including the fields like Biological, Environmental, Pharmaceutical and Agricultural Sciences. The Databases, software and tools available facilitate the solution of most of the biological problems. The present paper discusses the present status and application of Bioinformatics as an upcoming field.

**Keywords:** bioinformatics, biological data computational biology, molecular biology

## Bioinformatics is Born

Biology being blessed with Information Technology has nowadays no more purely remained an *in vivo* or *in vitro* study, but an *in silico* study. Major advances in the field of molecular biology over the past few years including the ever growing genomic data have led to a large amount of biological information which is difficult to decipher by the scientific community. Essentially bioinformatics area is retrieving, organizing, analyzing and storing the enormous biological data which will require the help of computational methods. It delivers easy access of information and projects a method for extracting only that information that is specifically asked by the biologists. Hence Bioinformatics sector is the quickest growing field in the country [1].

Biological data are being shaped at a unique rate [2]. As a result of this surge in data,

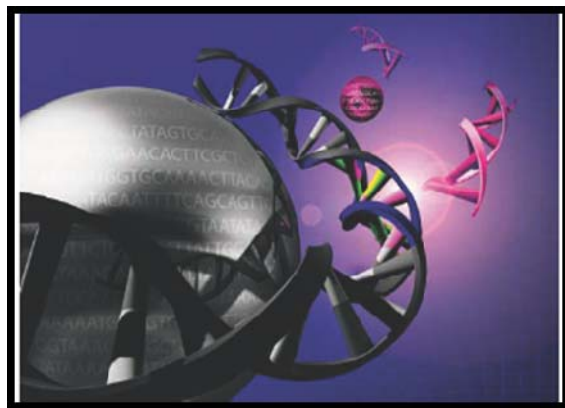


computers have become indispensable to biological research. Such an approach is ideal because of the ease with which computers can handle large quantities of data and probe the complex dynamics observed in nature. Bioinformatics, the subject of the current review [3].

Bioinformatics is an interdisciplinary research area at the interface between computer science and biological science. A variety of definitions exist in the literature and on the World Wide Web; some are more inclusive than others. Here, adopt the definition proposed by Luscombe et al. in defining bioinformatics as a union of biology and informatics: bioinformatics involves the technology that uses computers for storage, retrieval, manipulation, and distribution of information related to biological macromolecules such as DNA, RNA, and proteins.

The importance here is on the use of computers because most of the tasks in genomic data analysis are highly repetitive or mathematically complex. The use of computers is absolutely indispensable in mining genomes for information gathering and knowledge building.

### The Genesis of Computational Studies



Near the beginning of molecular biology research there were fundamental problems as to the algorithmic aspects of biological data. In that sense, the structure of DNA (Watson and Crick, 1953)[4] the encoding of genetic information for proteins (Gamow et al., 1956)[5] this era can be supposed as the birth of computational biology, with a number of key developments appearing. These initial approaches had already been combining computational and experimental information to better understand biological

macromolecules, and insights were gained on the evolution of genes and proteins (Ingram, 1961; Margoliash, 1963; Zuckerkandl and Pauling, 1965) [6].

### The Theoretical Crux of the Matter

The Computational problems mainly appeared in molecular biology, by the mid-1970s; when an eye-catching clear picture had been devised for the theory and practice of sequence alignment, the process of molecular evolution, the quantification of nucleotide and amino acid substitution rates, the construction of evolutionary trees, and secondary/tertiary protein structure analysis. In certain ways, a lot of the problems that would occupy the computational biologists of the future had been defined during those early years. What were missing are central reference data and software resources and the means to access them, a significant trend that would emerge very prominently during the next decade. One key development towards the end of that decade regarding public resources was the compilation of computer archives for the storage, curation and distribution of protein sequence (Dayhoff, 1978 [7] and structure (Bernstein et al., 1977) [8] information, a trend that would be amplified enormously in the immediate future.

### The Algorithms and Assets of Computational biology

The following decade was in effect the time when the field of computational biology took shape as an independent discipline, with its own problems and accomplishments. For the first time, efficient algorithms were developed to cope with an increasing volume of information, and their computer implementations were made available for the wider scientific community. Some commercial activity around software development has already been observed (Devereux et al., 1984) [9]

By 1980, it had already become clear that computer analysis of nucleotide sequences was essential for the better understanding of biology (Gingeras and Roberts, 1980) [10].

### With Awareness after the Fact

In 1992 terms of generic computing tools, there had been access to the Internet, mostly

through services like e-mail, gopher/ftp and the first web browser, Mosaic (http protocol), allowing access to a little more than 100 or so, (!) web sites. Computer systems were quite heterogeneous, including VAX/VMS machines and UNIX workstations there have been distributed databases, such as GenBank and Medline, but their availability was limited, mostly through CD-ROMs. CD drives were just being made available and the first version of X-windows was launched (graphical user interfaces were still in their infancy). About that time the first interpreted languages appeared, inspired by the UNIX utility awk and quickly followed by Perl and python [11].



### The Present and Future

History will record the late 20<sup>th</sup> century as a time combining the Molecular age with the information age. There is little doubt that today it is information and communication technologies that creates the greatest value and causes the most change. These technologies are credited with creating a new level of prosperity, enabling globalization, and generally changing the way we work, the way we shop and are entertained, the medical care that we receive, and the way governments serve their constituencies [12]

The global Bioinformatics industry has grown at a double-digit growth rate in the past and is expected to follow the same pattern in the next four years. US remains the largest market in the world, but Asia-Pacific countries, particularly India and China, are witnessing the fastest growth and are anticipated to emerge as the dominating forces in future [13].

### Aims of Bioinformatics

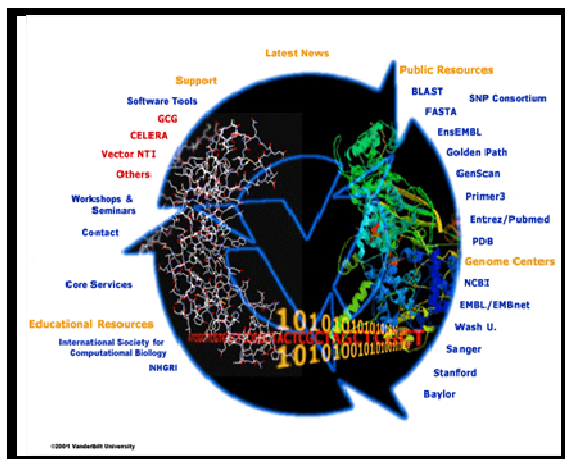
The aims of bioinformatics are threefold. First, at its simplest bioinformatics organizes data in a way that allows researchers to access existing information and to submit new entries as they are produced, e.g. the Protein Data Bank for 3D macromolecular structures [Bernstein FC et al. 1977, Berman HM, et al. The 2000] [14]. While data-curation is an essential task, the information stored in these databases is essentially useless until analyzed. Thus the purpose of bioinformatics extends much further. The second aim is to develop tools and Resources that aid in the analysis of data. For example, having sequenced a particular protein, it is of interest to compare it with previously characterized sequences. This needs more than just a simple text-based search and programs such as FASTA [Pearson WR, Lipmann et al. 1988] [15] and PSI-BLAST [Altschul SF, et al. 1997.] [16] must consider what comprises a biologically significant match. Development of such resources dictates expertise in computational theory as well as a thorough understanding of biology. The third aim is to use these tools to analyze the data and interpret the results in a biologically meaningful manner. Traditionally, biological studies examined individual systems in detail, and frequently compared them with a few that are related. In bioinformatics, we can now conduct global analyses of all the available data with the aim of uncovering common principles that apply across many systems and highlight novel features [17].

### Applications of Bioinformatics

The Bioinformatics can be mainly studied in various field of science like Data Retrieval Systems, Genomics, Drug discovery, Proteomics, Finding Homologues, Overall Genome Characterization, Molecular medicine, Personalized medicine, Preventative medicine, Gene therapy Drug development, Microbial genome applications, Waste cleanup, Alternative energy sources, Biotechnology, Antibiotic resistance, Forensic analysis of microbes, Bio-weapon creation, Evolutionary studies, Crop improvement, Insect resistance, Improve nutritional quality, Development of Drought resistance varieties, Veterinary Science.

With the current deluge of data, computational methods have become indispensable to biological investigations. Two principal approaches underpin all studies in bioinformatics. First is that of comparing and grouping the data according to biologically meaningful similarities and second, that of analyzing one type of data to infer and understand the observations for another type of data. These approaches are reflected in the main aims of the field, which are to understand and organize the information associated with biological molecules on a large scale. As a result, bioinformatics has not only provided greater depth to biological investigations, but added the dimension of breadth as well. In this way, we are able to examine individual systems in detail and also compare them with those that are related in order to uncover common principles that apply across many systems and highlight unusual features that are unique to some [18].

On the advent of a completely assembled human genome, modern biology and molecular medicine stepped into an era of increasingly rich sequence database information and high-throughput genomic analysis [19].



## Conclusion

Bioinformatics is an emerging field which is diversifying each moment and having applications in all fields. The advantage of minimizing labour and time makes it applicable in all realms of science. It provides an insight to the analysis of huge amount of biological data generated through the sequencing projects and proteomics. Thus bioinformatics has the power

to revolutionize the solutions to the core of all biological problems

## References

- [1] <http://www.christcollegerajkot.edu.in/binotes.html>
- [2] Reichardt T. It's sink or swim as a tidal wave of data approaches. *Nature* 1999; 399(6736):517-20.
- [3] Bernstein FC, Koetzle TF, Williams GJ, Meyer EF, Jr., Brice MD, Rodgers JR, et al. 1999 Drowning in data. *The Economist* 26 June. 6.
- [4] Watson, J.D. and Crick, F.H.C. (1953) Genetic implications of the structure of deoxyribonucleic acid. *Nature*, 171, 964–967.
- [5] Gamow, G., Rich, A. and Ycas, M. (1956) The problem of information transfer from nucleic acids to proteins. *Adv. Biol. Med. Phys.*, 4, 23–68.
- [6] Ingram, V.M. (1961) Gene evolution and the haemoglobins. *Nature*, 189, 704–708.
- [7] Schwartz, R.M. and Dayhoff, M.O. (1978) Origins of prokaryotes, eukaryotes, mitochondria, and chloroplasts. *Science*, 199, 395–403.
- [8] Bernstein, F.C., Koetzle, T.F., Williams, G.J.B., Meyer, E.F., Brice, M.D. et al. (1977) The Protein Data Bank: a computer based archival file for macromolecular structures. *J. Mol. Biol.*, 112, 535–542.
- [9] Devereux, J., Haeberli, P. and Smithies, O. (1984) A comprehensive set of sequence analysis programs for the VAX. *Nucleic Acids Res.*, 12, 387–395.
- [10] Gingeras, T.R. and Roberts, R.J. (1980) Steps toward computer analysis of nucleotide sequences. *Science*, 209, 1322–1328.
- [11] Christos A. Ouzounis I, Early bioinformatics: the birth of a discipline—a personal view and Alfonso Valencia 2 Bioinformatics 19.
- [12] M.K. Jhala, C.G. Joshi, T.J. Purohit, N.P. Patel and J.G. Sarvaiya Information Technology Centre, GAU, Anand.
- [13] Global Bioinformatics Market Outlook RNCOS, Sep 2007, Pages: 65
- [14] Berman HM, Westbrook J, Feng Z, Gilliland G, Bhat TN, Weissig H, et al. The Protein Data Bank. *Nucleic Acids Res* 2000;28(1):235-42.
- [15] Pearson WR, Lipman DJ. Improved tools for biological sequence comparison. *Proc Natl Acad Sci U S A* 1988; 85(8):2444-2448.
- [16] Altschul SF, Madden TL, Schaffer AA, Zhang J, Zhang Z, Miller W, et al. (1997) Gapped BLAST and PSI-BLAST: a new generation of protein database search programs. *Nucleic Acids Res.*; 25(17):3389-3402.

## The World of Marine Life Forms Based on Discards of Fishing

A. Venkateswararao  
NCSC-Vizianagaram, INDIA

**Abstract.** Biosphere is the region of earth where life occurs or it is the Life Zone of Earth. It includes air water and land. Almost all the part of the including the coldest poles, hottest deserts and the ocean depths supports one or other land of life forms. It is interesting to note that all the life forms on the Earth are interlinked into a hierarchy or web, the web of Life. Man is also a strand in this web. The Biosphere is a complex or distinct ecosystems that represent the interactions between a group of organisms and the environment or habitat in which they live and from which they derive energy and nutrients, Atmosphere, Hydrosphere, geosphere and authrosphere can be considered parts of the Biosphere. The Biosphere is the “Living Sphere” of planet Earth, bubbling with life forms. It is most remarkable feature of our planet that makes Earth unique within the planetary system. The evolution of life and biosphere began perhaps as early as 4.2 billion years ago. But only around 2.7 billion years ago life really started to have a significant effect on the atmosphere, Oceans and lithosphere Biodiversity is a relatively new word that means the variety of life forms in a unit area. An ecosystem is geographical unit with its own components such as Climate, Soil, water and variety of interlinked biota. All geographical areas or habitats do not harbor some kind or extent of biodiversity. India is a mega diversity country and study on biodiversity associated with various ecosystems and regions are important for the management sustainable utilization and conservation. The living species play a variety of roles in the ecosystems in which they exist. Till now 2,500 species of fishes have been recognized in world Mega diversifiable countries. India stands 9th, among them 1600 species were living in sea water. The fisherman take out use full fish from their nets and leave the non-commercial species plucked to their nets will be left out. During fishing by using different kinds of nets, a lot of non-target organisms are also trapped which are discarded after coming to the shore. An analysis of such discards in fishing villages and fishes harbor would reveal the

diversity of organisms in the Ocean. Main Objectives of the Project: - To document the diversity of Organisms in the Ocean. - To assess the impact of fishing methods and the types of nets used as non-targeted organisms. - To suggest remedial measure to minimize the impact on the non-targeted organisms.

### Methodology

Periodic visits to fishing villages and fishing harbors. - Record species wise / group wise organisms contained in the discards. - Note on the fishing gears used. - The diversity of organisms in the discards should be identified to the level possible with the help of fisheries department and other expert personnel.

### Analysis

The abundance of the different species / groups of marine organisms is analyzed from the data collected periodically. Attempts may be made to analyze the abundance and relative abundance of different species /groups in various seasons. The impact of different types of nets and fishing gears employed in fishing are to be evaluated.

### Conclusion, significance and problem solving

On the basis of the analysis on the diversity and abundance of organisms in the ocean can be obtained. Also the impact of fishing methods on the non- targeted organisms and the long term impact on the oceanic ecosystem. Remedial measures may be suggested to minimize such impacts. Restriction of trolling in certain seasons, restriction of certain kinds of nets and other fishing gear may be suggested in certain regions and seasons based on the study. Designing nets with turtle espe window can be recommended. The result of this simple project is helpful to impart awareness among the children and through them among the fisher community the necessity to adopt sustainable resources utilization methods and conservation of the ecosystem.

---

---

## Inculcating Scientific Temper among the Students of Sapuipara Janata Adarsh Vidyalaya

S.S. Ghosh  
PO: Bally, Belur, Howrah,  
Ph-09830565264, INDIA  
subhasankarghosh76@gmail.com

**Abstract.** Healthy minded people with a scientific attitude make a society healthy. But the very truth that science is an orderly and systematic exposition of knowledge on any subject is almost forgotten. Unfortunately our 'conventional' education system has failed to generate scientific temper among the children who are our future. In the following case study I have tried some novel approaches to generate scientific temper among the students of my school who belong to very poor families.

### A Case Study

#### Introduction

Sapuipara Janata Adarsh Vidyalaya is a Hindi-medium Senior Secondary School located in Belur, near Howrah. This school was established in 1968 to provide education to the children of the factory workers. It was upgraded to Secondary level only in 2000 and subsequently to senior secondary level three years back. As expected, the children belong to very backward and poor families among which majority of the students are First-Generation literate!

When I was appointed by School Service Commission and subsequently transferred to this school as a life science teacher in 2007, I was simply shocked. Though I was appointed as a PGT, there was no Science section in the +2 level. The school has a total area of only 2160 sq feet with no playground. The average size of the classroom is around 250-300 sq feet. There were around 1100 students from Class V-XII (>90 students in each classroom).

In the first few days, I could make out that the overall interest among the students for the science subjects is abysmally low. There was a latent fear and dislike for science. The very fact that science subjects could be mastered by enjoying and understanding was unknown to them. They believed that the only way for

learning is by cramming. Even the brighter students could not be stimulated to work hard at the secondary level as they knew that there is no Govt. school in the near vicinity which provides 'Science' in the senior secondary level and they can not afford to pay the high fees of the private schools. I could sense a feeling of frustration, helplessness and uncertainty among them about their future.

On analysis I found that most of them are studying just to obtain a pass certificate (Class VIII) which may help them to get a petty job. In fact the sheer drop in the number of students (by more than 40%) in class X as compared to the average strength of class V is a testimony to the above fact. To put it in simple words, the situation was alarming. Something must be done.

It was a challenge for me where my subjects were the children of this school.

#### Objectives

- To make the students love the subject I teach.
- Stimulate the students to apply Biology in their daily lives.
- Generating scientific temper among the students.

#### Methodology

##### Step 1: Building the foundation of the subject

I believe that just as a horse can not be forced to drink if he is not thirsty, similarly a child will never learn if he lacks an inner urge for it. To create that urge, the first step would be to make him love the subject. He must be made to explore and not just study the subject. For making his journey of exploration enjoyable, I planned to use some innovative ways which will ignite his latent inquisitiveness and talent. This will mark the first step in my goal of generating scientific temper.

This was done by the following methods-

To begin with, I divided the syllabus into two major sections- *Applied biology*, which touches their everyday lives and *Conceptual biology* that requires a certain degree of maturity.

I started with the 'Applied' section, as this is close to their heart. To make this section more interesting, I created stories related to different topics taking cue from my past experiences and from different educational programmes shown on Discovery and National Geographic channels. Before I went deeper into the chapter, I

encouraged the students to narrate some of the facts, they knew, about the topic. Eg. When I had to teach about medicinal plants, I instructed them to ask their parents and grandparents about the medicinal properties of different plants and their uses, which are known to them. Then they would share their new-found knowledge with the class. These activities made the class very interactive and lively.

In order to simplify the 'Conceptual sections' I employed a different strategy. **I believe that learning by doing is one of the most effective ways to master a difficult topic.** So when I planned to teach them the details of flower, I told them to bring the readily available *Hibiscus* (China rose) from their neighbourhood. With this model plant, I *transformed the class into a mini laboratory* where they were taught to dissect it and draw the same under my watchful eyes. This activity was followed by the study of many locally available flowers and comparing the results with the information given in the book.

Again for the part of animal physiology (frog's structure), I showed them *attractive charts* related to human physiology at first and then compared the same with that of frog's internal structure. As the quality of diagrams provided in their text is far from satisfactory, I simplified them by *drawing them with coloured chalks, made PowerPoint presentations* and stressed on making them draw the same. I always encourage the kids to draw and paste colourful diagrams on the class walls. These activities has not only improved their presentation skill but also helped them to retain the facts easily.

Added to that I *made the exam paper more conceptual and thought provoking rather than factual.* That was a pleasant surprise for them as now they could answer them even without cramming. Now that they knew that life science is a subject which is connected to their lives and is easy to score marks, they started liking the subject.

### **The turning point**

One fine day I taught the students of Class VIII about the different harmful micro-organisms that cause diseases and how unhygienic conditions help them to survive. To my surprise, the very next day every child contributed a rupee and bought two brooms and a disinfectant. Not only that they had cleaned their class on their own.



A Hibiscus (China Rose)



Students of Class VII studying and dissecting China Rose



Showing students of Class VIII a PowerPoint presentation

It was a first time that they had applied science to their daily lives. It was one of my happiest moments. Now I know that I have found the leaders of tomorrow who can bring a change in the society. But to face the world full of superstitions, they not only need knowledge but also a lot of self confidence.

**Step 2: Planning extra curricular activities for the overall development.**

Extra curricular activities help in the overall development of a child. It brings out the child from his shell so that he can express his potentials fully. To start with, I planned a singing competition, where the participants have to sing a patriotic song of their choice. This was followed by a quiz, a debate and a painting competition. The overwhelming response in these events encouraged me to take the final step.



**Winners of the Environmental Quiz Competition showing the name of their groups**



**Winner of the Debate competition, Preeti Pandit**



**Best adjudged painting on “ Global Warming” by Vivek Verma**



**Winner of Painting competition, Vivek Verma**

**Step 3: Laying the foundation of the Science Club, “KHOJ” on 1<sup>st</sup> Mar, 2009.**

‘Khoj’ was established with a goal of stimulating the students to go beyond the textbooks and conventional norms. It is a club run solely by the students where my role is that

of a mentor. The underlying principle of our club is-. SEARCH FOR TRUTH.

Initially the number of members was eleven. But within a span of six months, the number rose to one hundred and twenty seven. In this club there are two secretaries (one boy and one girl), who have been elected by the members. The student members, in turn, have been subdivided into groups of five headed by a leader. We meet every week on Saturday, after school where the groups discuss the task allotted to them in the form of a presentation. While one group is doing the presentation, all other groups have been asked to judge the presentation and give them marks. The total of all the marks is then allotted to that group. This activity worked as a real stimulator for all where one group tried to out perform the other.



Kundan Singh, the Secretary of 'Khoj', reading out the assignments

**Task 1-** Each group has to select a name of a scientist of their choice. Once they and make a presentation of the same in the weekly meeting of 'Khoj'. This task was planned to make them aware of the great scientists and may help them to appreciate their contributions.

**Task 2-** I had shown them the Hindi-version of an animated movie "Happy feat", on the school computer. The theme of the movie was 'Climate Change'. Before they could enjoy the movie, I made it a point that while watching the movie, they should note the names of the different kinds of penguins. It was Educatainment (Education+Entertainment) in a real sense.

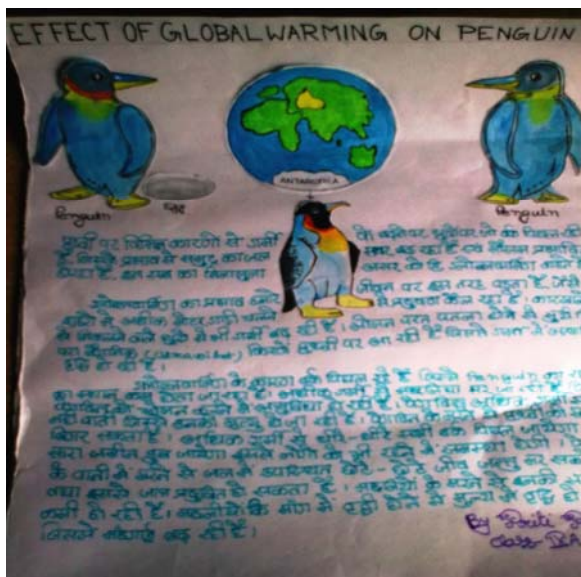
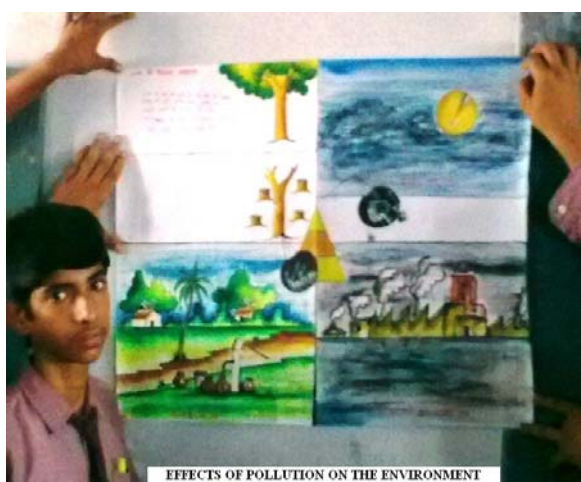


Chart describing the Effects of Global Warming on Penguins



Task 3- Project on Oral Cancer:



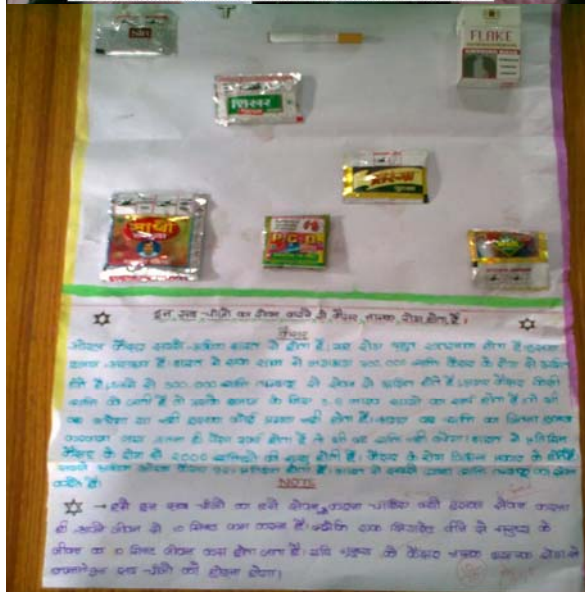
Each member of 'Khoj' was asked to visit five neighbours and note the total number of members who are addicted to different forms of Tobacco. After the survey they calculated the percentage of addicts. Then they had made a project on Oral Cancer. Interestingly some of them have written poems on cancer, made some colourful charts. On teacher's day, some members staged a play on the same topic.



MEMBERS OF 'KHOJ' LISTENING ABOUT ORAL CANCER DURING THE BISEKULAR MEETING.



MEMBERS OF 'KHOJ' SHOWING THE VARIOUS FORMS OF ORAL CANCER CAUSED DUE TO TOBACCO



Causes of Oral Cancer



Deadly words written with crushed Tobacco leaves

The above project was such a hit that all the members vowed not to consume tobacco in their lifetime. They have even managed to convince some of their family members to discontinue consumption.

**Task 4-** One meeting was dedicated to make students aware about SWINE FLU, by conducting a small quiz and a lecture.

#### Ongoing Tasks-

- An awareness campaign on Water conservation and Rain water harvesting.
- Members have been asked to find five medicinal plants from their localities. They are then required to make a project on the same which will comprise the following-
  - Making a herbarium of the plant.
  - Explaining the morphology, physiology, habitat and cultivation technique of the plant.
  - Explaining the part used for making medicine.

#### Observations

There is a marked improvement in the academic performance of the students. I was very happy to find that not a single student of my class X have failed in Life Science in this year's Board examination.

I am happy to announce that our club has been given affiliation by VIPNET.

#### Discussion and Analysis

The same students who used to run away from studies are now actively pursuing the same. The classes are humming with activities and hope. The effects of various projects are percolating their homes too.

If everything goes according to plan, I wish to celebrate Science day, next year where parents would be invited and students would put up a lively performance on various scientific topics.

### **Inference**

These projects have illuminated not only the minds of the children but also developed a degree of scientific temper in their homes. I strongly believe that these small steps will act as giant leaps in future.

This case study proved that irrespective of the background that a child is coming from, everyone has a scientific temper embedded within. If the same can be aroused by going beyond the conventional ways, it can bring miraculous result. This in long run will benefit not only the students but also the society at large.

---

---

## **Interacting Education Regarding Environment Protection and Self-Willing Encouragement**

R. Busa, F. Cimpoa, D. Vladu, L. Andrei  
and M. Enache  
Economic "Costin C. Kiritescu" High  
School, Sector 6, Bucharest, ROMANIA

### **Introduction**

Starting on 13.11.2008 was signed a partnership agreement between the High Economic "Costin C. Kiritescu" and Association "Ecology-Sports-Tourism" (Aesta), in order to implement the project "ECOCLUBURI for Nature", developed in partnership with the Inspectorate School of Bucharest, Bucharest Youth Foundation, House of Teachers of Ilfov County Administrations National Parks Craiului Stone, Comana Cozia and Bucegi County Association Sport for all "Ilfov and Public Service Rescue Zarnesti. The objectives of this partnership are: Encouraging associatively between young students; Promoting environmental protection and eco-voluntary; Promoting Sport for All. The project follows the establishment of youth associative structures, within which to promote environmental protection and volunteerism, especially in protected natural areas network in Romania. Ecoclubs members will be involved in extracurricular activities and education for animation and volunteer in activities of awareness on the importance of the environment, biodiversity conservation in protected natural areas network.

### **Project activities carried out by members of our high school Eco-Club**

1. Saturday November 8, 2008, the "Screen Club, I attended a meeting with members in high schools created eco-clubs project partner. On this occasion we aimed to provide a suitable framework for socialization between members' eco-clubs, but also between them and the project team members to our association. Another objective of the meeting was to familiarize young people enrolled in a project with specific equipment eco-

volunteer by a presentation of some of the members supported the practice of project team (Adi, Bogdan, Miha and Radu). Also on this occasion was made and a video projector presentation Cozia National Park, the destination of the following practical applications scheduled for the project, during 15-16 November and 22-23 November 2008.



**Screen Club**

2. Friday, 05/12/2008 between 17:00-20:00 hours, in organizing the Youth Foundation of Bucharest, held in "Screen Club" event Dec. 5 - DAY VOLUNTEERS ", to which our eco-club's members participated with students and teachers enrolled in this project. Participants have worked in several workshops, supported by these NGOs for youth:

The concept "Eco-voluntary": presentation by means of slide shows and a documentary film made in the image eco-voluntary camps held in 2008, supported by the Ecology-Sports-Tourism Association.

"Volunteers for Europe" was approached volunteers mobility throughout Europe, is projecting a documentary film themes, by supporting the interactive dialogue with participants. Organizer: Association "Volunteer for Life".

"Examples of good practice in working with volunteers' exposure sustained by Mr. Adrian Apostol, youth trainer in the Association "Sakura".

"They want young people to be volunteers?" Debate moderated by the team "Teen Press"

magazine young high school students in Bucharest.

Also, participants had the opportunity to admire the photo exhibition with the theme, arranged on this occasion by youth NGOs members of the Youth Foundation of Bucharest.

The evening ended with mountain folk music and songs, sung by young high school students and members of participating NGOs.



**National Park Cozia**

In the project Eco-clubs for Nature, I participated in the days 22-23 November 2008, the first practical application in Cozia National Park.

Sanitation activities were conducted in the Valley and Valley Lotrisor Pausa, Arutela Roman camp area, within which were collected a total of about 50 bags of waste being transported interest by Park rangers with the equipment in cars, the pit Calimanesti city garbage. Were organized visits to monasteries Cozia Stanisoara, Turnu, hiking mountain chalet games, competition for tourist orientation. Also, the director of the National Park Cozia-Mr. Paul Prundurel to a presentation, richly illustrated on the natural potential of the tail. In the application have been followed and fulfilled several objectives: to promote a program of spending free time useful, awareness on the need of nature protection and especially protected natural areas, encourage associability and (eco) volunteering.



**Bucegi National Park**

4. A new application for Nature in the project Ecocluburi took place in the days of 24-25 January 2009 in the Bucegi National Park.

Attended high school students accompanied by teachers' M. Basarab ", C. Kiritescu ", V. Babes ", H. Coanda ", C. Nenitescu ", M. Bravu ", E. Lovinescu "and" Gh Airinei-PTTR. Movement was made by bus on the route Bucharest - Targoviste - Moroieni - Venus - Cold Brook. In Moroieni, we stopped to visit a documentary at the Bucegi Natural Park Administration, on which occasion the director of Park-Horia Iuncu-and some of his colleagues organized a presentation of the main activities carried out in a protected area - organization, goals protection, awareness and patrol actions. The application continued to hike the forest road that connects over saddle Baiului cottage Diham the national road Predeal - Cold Brook. Good weather and impressive scenery of Bucsoiului always accompanied us.

Young people were familiar with basic notions of group travel on a mountain trail, understanding the rules imposed for safety and smooth operation of an excursion. Clear sky allowed us in moments of leisure to make beautiful horizon tours to masivii cities: Postavarul, with keys Rasnoavei, Piatra Mare, Garbova and, particularly, Cabana, with fiorosii Colti of Morarului and ametitorul Bucsoiului steep.



At Cabana Diham we arrived at noon, being received, as usual, with warmth and good vibes. After a well deserved break, during which we checked and we had lunch, the program continued with a drawing competition, in trying to choose a logo and a slogan for the project Ecocluburi for Nature.

For two hours everyone enthusiastically drew trees, leaves, mountains and people in general attempt to convey their peers, through a symbol, the need to protect nature, increasingly

beleaguered, shouting for help. Pastime games preparatory attendants - Aesta members have animated atmosphere late into the night, an opportunity for participants to know better, to have fun together, and to share the joy of all travellers on mountain paths.



Sunday, after breakfast, a contest was organized guidance Magura ashes. Young travellers calculated angles and distances march took landmarks, compass the main object of interest. They gathered together the experience needed to use an indispensable tool of every tourist in the mountains.

Way back we fought back in the Saddle Baiului, where, on the blue triangle we descended, with attention because of ice and snow to the Cabana Diham. From there the landscape was gradually urbanized, accompanying us to the logs with machines and lots of people.



**Branesti Forestry**

5. 20/03/2009: Action for forestation and sanitation in the area of forest Branesti of the range Branesti Forestry. In this action participated 50 students and teachers, volunteers from high schools within ecocluburilor Partner: National College "M. Basarab "National College" V. Babes ", High School of Aeronautics" H. Coanda "High School of Building" M. Bravu "High School Chemistry" C. Nenitescu "Technical College Media, College of Economic 'AD Xenopol "Economic High School" C. Kiritescu "and High School" E. Lovinescu. Sanitation was held in the body of forest Grunau, made of oak brought the German region homonymous planted 90 years ago and the site of afforestation has been arranged on a degraded land nearby. The action took place in partnership with the Bucharest Youth Foundation and the support Branesti Forestry, Eco-Rom Packaging Romania and Rosal Group. Dissemination among high school students will make and through high school magazine "Teen Press", the number of April, which will be distributed in a number of 1000 copies.



**Protective functions of forest**

6. 25/03/2009: Exposure and video projector on "protective functions of forest. Recreational and tourism functions of forests from around the Bucharest "was supported by Dr. Ing John Machedon. In its continued Mr. Michael Zotti ing of the Service "Protected Areas" has held a full statement presentation video projector Craiului Stone National Park, where you place the fifth edition of the Trophy "Forest". High school students and teachers were able to partner eco-clubs admire and the thematic philatelic exhibition arranged at the headquarters of the RNP "ROMSILVA" on Magheru Blvd.



**National Park Piatra Craiului**

7. 28-29.03.2009: Trophy "Forest"-edition will-organized National Park "Stone Craiului", in partnership with the Bucharest Youth Foundation and the Association County Sport for All "Ilfov, with the support of Public Service Rescue Zarnesti Administration and the National Park Piatra Craiului. climbing competitions were held and attended by tourism orientation about 50 high school students in High School Chemistry "C. Nenitescu "High School" E. Lovinescu "Economic High School" C. Kiritescu "High School of Aeronautics" H. Coanda "and High School" D-Tru Dumitrescu of Buftea. Climbing competition Delia Vladu of our high school student took the prize II and in our high school team trophy Forest took place III.





## Recovery of Silver in Laboratory Residual Suspensions

A.S. Machado-Ribeiro, F. do Couto Maia,  
R. S. Pereira-Couto and J.M. Pereira da Silva  
Colégio Internato Dos Carvalhos, Rua do  
Padrão, 8 –4415-284 Pedroso Vila Nova de  
Gaia–PORTUGAL  
sofia.ribeiro@cic.pt; filipa.maia@cic.pt;  
raquel.couto@cic.pt; zemanel@cic.pt

### Instead of conclusions

Following participation in scheduled classes, the more prepared students will receive a certificate and a pass eco-voluntary animator youth activities and sports for all, that certify their professional training. At the end of the project will be organized a network of youth associative structures, within which students involved in the project will act as volunteers with appropriate training, able to run extracurricular activities and environmental protection education, animation and volunteering.

Multiplication Project and other education units, with the support of students trained in youth associative structures already established, will lead to development of the eco-clubs, becoming a partner in the implementation of youth projects undertaken by school districts, Foundation for Youth and Youth Directorate of Bucharest.

---

---

**Abstract.** At school laboratories, methods titrimetric of analysis are frequently used having silver nitrate solutions as the main reagent. They are usually designated by precipitation volumetries. The residual suspensions of the precipitates, which result from these analytical methods, must be kept in a bottle of leftovers, so that they can be used later on to retrieve silver. Otherwise, if these residues are rejected along with inorganic ones, silver could be completely lost. The work consists of a set of unit operations such as: decantation, filtration, fusion and unit processes, highlighting reactions of precipitation, complexation and oxidation-reduction. The residual suspension, containing the silver precipitates, is previously treated by digestion in an environment which is strongly acid with HNO<sub>3</sub> and HCl, which is done in a laboratory hotte. Then the solution is treated with potassium permanganate (KMnO<sub>4</sub>), hot, in a way to obtain a highly pure silver chlorine residue. After cooling the precipitate is filtered and the solution, which is silver ions free, is rejected after testing the presence of chlorine ions. The residue of silver chlorine is then dissolved in a watery solution of ammoniac (NH<sub>4</sub>HO a 25%), in a way to obtain a solution of diaminosilver ion ([Ag (NH<sub>3</sub>)<sub>2</sub>]<sup>+</sup>). The complexed silver solution is treated when cold by adding a solution of ascorbic acid in order to precipitate all the silver. After decantation, a new filtration is carried on and the remains that don't have silver are rejected. The silver residue that sticks to the paper filter dries up and calcinates in the oven at 1200 °C in the presence of borax that plays the role of a fusible and holds impurities back. The ceramics melting pot, containing the liquid silver, is carefully emptied into a tall goblet with plenty of ice and water. Thus we have highly pure silver greisens. With this experiment, everything that might be a residue about to be

rejected is treated according to scientific knowledge, usually conveyed in secondary schools in an undetached way. The integration of knowledge, the laboratory work and the team work emerge as an example of an integrated co-operating kind of learning.

---

---

## Impact of Fun Learning in Classroom for Science Education

R. Purohit

Satyabadi Bidya Pitha, Kalapathar, Dist-Subarnapur-ORISSA, INDIA

radhepurohit@yahoo.co.in,

Rspurohit1@gmail.com

**Abstract.** Science is being thought in the School right from the beginning still scientific attitude, scientific temper, scientific knowledge and scientific wisdom are not being practiced. It is only for the syllabus sake no doubt formal science education does not play a significant role in scientific attitude formation why it is not still reaching the unreached. All the mass media are projecting the importance and value of science regularly in different format Govt. Dept, NCSTC, DST, Science City, Science centre are implementing so many project for popularizing of science through various means.

The foundation stone of Science education and awareness laid in our education system. However, there are serious concerns about the state of science education in our school and college. In making science attractive and promoting science awareness however it is vitally important that is the community is able to relate science to everyday.

### Indian education system:-

Emphasis is laid on cramming consequently the child has to face great difficulty due to the lack of imaginative faculty. When he steps up the ladder of higher classes of science. As such only for learning can enhance the thinking capability of children and to bring them out from the vicious circle of cramming. This paper highlights the impact of fun learning in our classroom.

After the MacAulay's Indian education system has undergone many changes but many shortcomings still persist, There is a lack of interaction between the students and the teachers. This is the main drawback of this system. Examination system has also been an intricate problem. Only student having cramming capability can get through the examination regardless he understands something of it or not. It has also installed a feeling that whatever is

thought in the classes have no relation with the realities of life.

#### Education in the classroom:-

When we think of teaching science even in the practical class the student is not free to make experiments of their own. These make the science a cumbersome learning. Consequently the students prefer to cram the facts rather than to understand.

Science teaching should not be unsavoury and boring in an environment of strict discipline the teaching should be interesting, enterprising with a touch of history and humanity. To some extent discipline it may be akin to the teaching of Social Science. The student enjoy freehand like a research scholar for self study instead of subjecting them to long and boring full of Mathematical calculation.

Despite of all efforts super natural elements are still there in most of the village. Even educated people in that village are following the old custom and the super natural elements without insisting the scientific attitude and scientific knowledge. To inculcate and developed scientific knowledge building we have to find out some ways and means for sustainable scientific practice promote scientific attitude enhance scientific temper and inject scientific wisdom. This paper will highlight the important aspect of scientific knowledge building through fun learning.

---

---

### Furthering Agricultural Education for Forthcoming Challenges

G. Papnai<sup>1</sup> and I. Prabhakar<sup>2</sup>  
Department of Agricultural Communication  
G.B.Pant University of Agriculture and  
Technology, Pantnagar 263145,  
Uttarakhand, INDIA

**Abstract.** India has one of the most diversified agricultural education, research and development systems in the world. It is supported by about 30,000 scientific personnel including more than 7,000 of those engaged in active education, research and management. This vast network is coordinated by the Indian Council of Agricultural Research on the pattern of UGC as it does in case of traditional universities. In respect of NARS family, we are proud to have around 100 national institutions, 10 International centers, 5 National Institutes with deemed-to-be university status, one Central Agricultural University and 41 State Agricultural Universities. There are 558 KVKs and 8 Trainer's Training Centers for transfer of technology. This huge strength of human resource, infrastructure and resource network is the result of the continuous growth in priority sectors for effective education, research, extension and developmental activities in agriculture. In addition there exists a large network of large number of postgraduate and graduate institutions/colleges in the country that impart agricultural education. Several autonomous bodies including NGOs are also engaged in research and extension activities in agriculture and allied fields.

We have developed strong agricultural education system since independence. The establishment of State Agricultural Universities (SAUs) on the pattern of Land-Grant Colleges/Universities of the United State contributed to the reorganization and strengthening of agricultural education system in the country. The green revolution, with its impressive social and economic input would have not been possible without the contribution of these centres of learning in the form of development of trained scientific manpower, the generation and assessment of new technologies and their dissemination to farming community. The human resource developed in agricultural education system has been instrumental in



agricultural transformation in the country. However, the agricultural education system has not kept pace with the rapid technological development taking place globally. During the early part of the establishment of SAUs the academic programmes were structured to produce graduates who became primarily technology agents in the present era of specialization and development in modern science, it is necessary that we restructure our agricultural education in a manner that the graduates coming out are analytical, technology oriented, sensitive to social and economic issues of farming in India, and able to meet the challenges of new millennium with determination, zeal and commitment. Majority of them should become job providers rather than job seekers. While the above steps are being taken to improve the human resource development of agricultural graduates, the glamour of government jobs dominates in our thinking, though in recent years, private sector has begun in big way to absorb some of our graduates to become entrepreneurs.

The future strategy for agriculture is going to be very different in view of increased population, increased demand for food and other commodities vis-à-vis over exploitation of natural resources, depleting land and water resources, and depleting genetic diversity. With the liberalization of economy, a number of multinational companies with high-tech agriculture are entering into agriculture sector and the competitiveness is increasing. The challenge before us is how to reorient our agricultural education to make our graduates competitive nationally and internationally. Of late, there has been widespread consensus that quality of graduates in various disciplines of agricultural sciences does not match with the changing needs. Hence, there is urgent need for upgrading the quality and standards of higher agricultural education.

### **Challenges of agricultural education in present scenario**

The agricultural scenario of the country in the twenty first century is radically different in view of the following facts:

i) Like extension, the research and education programmes in agriculture with the existing level of government funding will remain

constrained in regard to facilities and resource mobilization. It will seriously jeopardize the quality of output. Hence, there is an utmost need to strengthen the linkage between SAUs and ICAR institutions and other organizations, and also to involve new institutions and organizations in the collaborative efforts to attain the common goals.

ii) External factors like WTO, GATT, GATS, IPR, GMO and several other trades and export-import related policies have also contributed to the need of strengthening complete agricultural research and education system in the country. These factors also provoke to reorient the on-going research and extension programmes.

iii) In order to compete successfully in the field of globalised agriculture, it is essential that agricultural research, education and extension system has a free access to information communication technologies and facilities so that its efficiency could be harnessed for the betterment of Indian farming community in this competitive era of agriculture.

iv) The need for a change in the existing system is also visualized in view of the fact that more money and resources are needed for various programmes on account of escalation in cost of equipment, infrastructure and salaries. The necessity for modern equipment and facilities in agricultural research and education system has long been felt. It is becoming apparent that limited resources of the government cannot meet the existing requirements. Hence resource generation has also become a primary focus of attention.

v) Distance education in agriculture has been perceived as an emerging area of intervention. In order to make it rewarding nonformal and vocational education packages will need to be developed. Collaborative efforts of SAUs, ICAR institutions, mass media organization and apex institutions like IGNOU and other open universities will, therefore, become inevitable.

vi) Possibilities should be explored as to how SAUs can become global partners in imparting education in agriculture and allied fields.

## The Context

Agriculture will continue to be a major contributor to the economies of the most developing countries. However, in many developing countries like India, the agricultural sector is undergoing rapid changes as a consequence of both technological progress and an industrialization process that calls for an increased market focus, competitive practices and higher productivity. Employment opportunities in off-farm agriculturally related activities are expected to increase at a faster rate than in production agriculture. Agricultural education curricula need to be redirected to address the changing needs and new challenges to usher in Green Revolution –II which will be different from the first Green Revolution in terms of approach and concept. While the first Green Revolution focused mainly on food production to achieve self sufficiency, the Green Revolution-II will address not only more agricultural production from less land and less water, but also global competition in marketing, value addition in farm products, sustainable management of natural resources, environment protection and socio-economic issues.

Sustainable agriculture presents a deeper and more fundamental challenge than many researchers, extension personnel and policy makers previously assumed (Pretty, 1995). “Sustainable agriculture needs more than new technologies and practices. It needs agricultural professionals willing and able to learn from farmers; it needs supportive external institutions; it needs local groups and institutions capable of managing resources effectively; and above all it needs agricultural policies that support these features” (Smith, undated).

Everyone recognizes the critical role played by agricultural professional in transferring the new technology to end-users. They are involved in assessing farmers’ technology needs, and technology development, evaluation and transfer. But there is growing concern whether today’s agricultural professionals have adequate knowledge and skills to be effective in the current situation. “It is clear that if we as agriculturist are to make effective progress, we must change the way we plan, conduct, and communicate about research. Any component of a farming system can become the limiting factor to sustainability. It is therefore essential that

those who work with farmers to develop sustainable systems are knowledgeable about the system with which they work (Reeves, 2000).

It follows that capacity building and professional development are fundamental prerequisites for achieving the widespread adoption of sustainable agricultural practices. Particularly important targets for these efforts are those agricultural professionals that are so vital in bridging the 2-way farm technology gap the gap between what is known about sustainable agricultural practices and what is being applied at the farm level, and between what farmers know about sustainable agriculture and what researcher needs to learn. “Much information is unavailable or in accessible, particularly to poor farmers, many practical lessons have been learnt but not shared, and there are few opportunities for dialogue to enable concerns to be resolved”. (FAO, 2000).

The universities have to develop and strengthen for both formal and non-formal education programmes to bring academic excellence relevant to future needs. Though, the curricula have been modified, physical facilities, equipment and teaching aids have been updated to some extent and facilities have been made for training of teachers in educational technology at National Academy of Agricultural Research and Management (NAARM), Hyderabad and Academy of Agricultural Research & Management (AARM) in some SAUs, they are far from adequate. Teachers in SAUs are selected mainly on the basis of their professional degree and experience. The problem of inbreeding in the faculty in SAUs has assumed an alarming proportion. Further more, the beginner teachers do not have any formal pedagogical preparation. Training of faculty was greatly aided during the decades of sixties through various faculty developments and exchange programmes auspices of US Technical Co-operation Mission and the later the USAID Six American land grant universities participated in the faculty exchange programme with eight SAUs in India. Similar arrangements under Indo-US Knowledge Initiative on anvil.

Educational systems are dynamic in nature, continuously adapting to meet the emerging needs of society. In the era of WTO it is very much necessary to improve the quality of teaching for professional development of teachers as well as students. More than ever

before in our history, education will make the difference between those who will prosper in the new economy and those who will be left behind. Thus, it is necessary that improvement programmes are run to improve quality of teaching sooner than later. Professional development of agricultural education demands revolution in teaching.

### **Teaching Agriculture**

Pantnagar University has adopted Diversified Practical Crop Production (DPCP), Rural Agricultural Work Experience (RAWEx) and Agri-Business Management (ABM) which have a deep impact on quality of education. Education in Agriculture needs a different treatment which should be experiential in nature. Presently, there is urgent need to move away from didactic teaching and look for new instructional approaches like student-centered teaching, problem solving, action learning, experiential learning, project mode, etc. It is necessary to experiment with methods of teaching for improvement of quality and professionalism. An educational system is a group of components like student, teachers, media, materials and educational objectives working together in organized fashion. Application of innovations of science and technology along with humanities, social sciences and education is mandatory in achieving the goals of education. It is here that science of educational technologies comes in picture to analyse the process of education and solve the problems of teaching and learning. Thus, advances in educational technologies must now be used to systematically design, implement and evaluate educational process. It is necessary to experiment with methods of teaching for improvement of quality and professionalism.

### **Linkage for Reorganization of Agricultural Education**

Agricultural education at present is being implemented at four levels:

- a) Doctoral level
- b) Master's level
- c) Undergraduate level
- d) Vocational

While the country is proud of having four deemed-to-be-universities of national importance

supported by ICAR for higher research, it would be desirable that more emphasis is placed on doctoral education at these institutions and only on master's level programmes in subjects which are not available in SAUs. This would facilitate better utilization of resources for higher education. SAUs generally cater to the regional/local needs in their teaching and research programmes which are affected through doctoral, master's and undergraduate programmes. Its main emphasis, however, has to be on improving the quality of education by making course content and curricula need based, more practical and field oriented without compromising on theoretical knowledge. Periodic updating/review of syllabi will be integral component of quality-oriented education. A quality based teaching/ research programme will make the graduates and postgraduates of SAUs better scientist, extension workers and entrepreneurs in future.

### **Linkage for Strengthening RAWEx:**

The programme of Rural Agriculture Work Experience (RAWEx) was initiated in all the SAUs to build up the confidence of the students in the application of agricultural technologies in rural setting and in other management as well as operational aspects. For this purpose students are required to have multi-institutional experience and exposure through learning by doing. Hence, linkage with ZRS, Zonal ICAR Centers and other institutions including KVKs and agro-based industries would be essential for all the SAUs.

### **Utilization of facilities at local institution for postgraduate education**

To meet the specific training requirements at master's level it has been experienced that the requisite facilities like fields, equipment, funds, etc., are sometimes not available at postgraduate colleges and SAUs. On the other hand such facilities are available at zonal research stations of the SAUs and also at local research stations of the ICAR and CSIR. With a participatory spirit ensuring coordinated efforts for improvement in education, the graduate and postgraduate students can be attached to these stations for having a better training and optimum utilization of facilities at the local research stations. This will also help in strengthening the activities of

the local research stations by adding manpower on research programmes without additional investment.

### **Constitution of a Coordination Committee for Research and Extension**

Each agro-climatic zone is represented by SAUs, ICAR institutions and other local research stations/sub-centers. There also exist other institutions like traditional universities, CSIR institutes and DRDO laboratories which are engaged in similar research programmes. There is no coordination on zonal basis among these institutions to make research programmes of these institutions inter-dependent and supportive of each other. Coordination among these institutions will facilitate initiation of new areas of research thrusts. Unfortunately, the location specific requirement of education, research and extension does not remain the jurisdiction of only one institution as at present especially in view of the fact that for the same role we have several institutions in each agro-climatic region. Hence, effective coordination is essential to avoid duplication and multiplication of similar research programmes, facilities and equipment. It will also make the joint efforts cost-effective in attaining the goals of education, research, extension and transfer of technology. In view of this each agro-climatic zone may have a coordination committee headed by Vice-Chancellor of the SAU representing the specific agro-climatic zone and heads of the different ICAR and other institutions as members. In many cases in the same agro-climatic region there may be two SAUs. In that case the two Vice-Chancellors could act as Chairman on rotation basis. However, considering the apex role of the deemed universities they may have a separate coordination committee headed by its Director as chairman and other heads of the institutions including Vice-Chancellors of the SAUs as members. It is hoped that such coordination committee will be able to set the agenda based on the national/regional requirements to provide supportive role to the apex institution. This will also solve the problem of technology transfer by those institutions where requisite staff and facilities have not been provided by their respective departments.

### **Linkage and Coordination for Training and HRD**

In view of the fact that the SAUs are multi-faculty organizations established on the basis of the location specific needs of the country, these are obliged to focus on the HRD through its various degree programmes. At the same time some of the programmes of human resource development through training and refresher courses as undertaken by ICAR need to be decentralized from national level to SAU level where the research scientists, teachers, trainers and extension workers can be provided additional facilities and orientation and refresher courses on periodical basis. The trainer's training on regional basis through SAUs has a greater relevance than providing the same through national level institutions. However, in frontier areas of research and education we may continue the system of having orientation and refresher courses through national/apex institutions. In such highly specialized areas ICAR may itself arrange trainers' training.

In order to make higher education/research more rewarding time has come to evolve appropriate strategies for developing sandwich Course programmes involving SAUs and ICAR institutions. These programmes would envisage participation of various institutions jointly to undertake teaching and research programmes of students pursuing higher studies. The choice of participating institutions in this regard would depend on the specific requirements of the students/region.

Possibility should also be explored to make reciprocal arrangements for higher education especially at the centers of excellence among SAUs. Such an arrangement would permit sharing of seats especially at doctoral level in the identified areas of study by two or more SAUs and/or ICAR institutions.

### **Updating curriculum**

There is need to continuously revise curriculum according to the needs of the market. Participatory curriculum design should be practiced to gauge market and bring consensus among stakeholders. The curriculum must focus on development of employable skills, and strategies should be designed to develop those skills. This calls for innovations in teaching

methodology. The following subjects need to be included in the curriculum of agriculture graduates:

- 1) Good agricultural practices for field crops, fruits and vegetables
- 2) Biotechnological tools for crop improvement
- 3) Organic farming
- 4) Micro irrigation and fertigation
- 5) Agribusiness
- 6) International marketing, WTO and IPR
- 7) High-tech agriculture and precision agriculture
- 8) Value addition and post-harvest processing
- 9) Expert system and ICT applications
- 10) Hands-on training in agri-entrepreneurship such as quality seed production, mushroom production, apiculture, commercial horticulture, floriculture, bio-fertilizer production, biological methods of plant protection, food processing.

The success of academic institutions in agriculture will be known by their responsiveness to change. Significant social forces have created both opportunities and challenges. The need of the hour is to capitalize on the strength of our knowledge and experience and manage them creatively to add value to the products. Are we ready with needed attitudes and skills to achieve success?

### **Agricultural Education to further agricultural development**

A speaker at a UNESCO sponsored conference noted that “While there are many complex factors that influence sustainable development and food security, it is clear that education in agriculture plays an important role in preparing farmers, researchers, educators, extension staff, members of agri-businesses and others to make productive contribution. (Lindley, 1998)

The situation calls for major changes and even a transformation in the way we view and implement agricultural education. Perhaps the most fundamental of the changes required will be to realize the tremendous need for continuing education programmes for agricultural professionals.

### **Pantnagar Model of Agricultural Education**

There has been a rapid growth in SAUs after G.B. Pant University of Agriculture and Technology was established in 1960. However, only few of them have achieved benchmark in quality of education. The output, intellectual capital, research or knowledge base expansion have been much less than expected. Agricultural education is becoming a passive experience and need redressal. Thus, to make agriculture education interesting and employment oriented a paradigm shift in vision and approach will be needed both from institution and faculty, having the partnership with stakeholders.

G.B. Pant University of Agriculture and Technology has played a key role model in agricultural education by providing innovation in teaching techniques, faculty up gradation and integration. Practical Crop Production (PCP) and Rural Agriculture Work Experience (RAWE) are some of the innovations, which have been successfully implemented by other State Agricultural Universities. Alumni of Agriculture College always cite the examples of this course for their success in their career. This University also was on the forefront, in exercise by ICAR for curriculum uniformity across the country. The course curriculum for B.Sc. Ag was revised in 1998. Recognizing the technological changes, needs in changing scenario, course curriculum have been reoriented recently, by incorporating new courses of relevance such as Micro-irrigation, Organic Farming, Integrated Pest Management and upgrading courses as per technological changes. Hands-on training in mushroom production, apiculture, floriculture, food technology, besides crop production has been added. RAWE programme has also received focus with respect to project formulation, appraisal and implementation, plant health clinic, PRA and industrial attachment. Short optional courses have also been taken up for developing communication skill and improving personalities. These efforts have shown a positive impact on the graduates.

In order to be competitive and to meet the present demand in changing scenario, we may have to focus on the following:

- 1) Development of the ability of students to apply knowledge for solving problems

- 2) Analytical and diagnostic skill upgradation for enhancing decision making ability
- 3) Development of imaginative and innovative solution to deal with the situation
- 4) Harnessing the potential of leadership and team member for handling o the problem
- 5) Generation of entrepreneurship skill and motivation for self employment.

### Soft skills needed

The students in agriculture require competencies in group discussion, panel discussion, analytical ability, which have received less attention. They also require confidence and techniques to deal with the situation. To inculcate the soft skill the faculty with above skills and experience would be needed. Coordinating seminars, workshops, panel discussions, organizing inter-institute competitions, conducting research, conducting trainings, supervising projects, developing case studies are some of the approaches to improve the soft skill of the faculty, who can provide the skill to the students.

Education, a means of empowerment and social development assumes much significance, when agriculture is added to it, since agriculture is looked upon for employment with multiplier effects and economic development.

### Organization and sharing of student's activities at zonal and national level

While sharing of physical and financial facilities is considered an important means of collaboration, sharing of heart and mind of the students and faculty members through inter-institutional programmes like sports, quizzes, debates, essay competition and cultural programmes is equally important. Activities in this regard could be organized by SAUs and ICAR units on a regular basis.

### References

- [1] Lindley, W.I. (1998) The Relevance of Higher Education in Agriculture and Rural Development. Speech delivered at World Conference on Higher Education; Higher Education in Twenty first Century; Vision and Action . UNESCO, Paris, 5 9 October [Online] Available: <http://www.unesdoc.unesco.org/images/0011/001170/007075e.pdf> Pretty, J.N. (1995). Regenerating Agriculture: Policies and Practice for Sustainable and Self-Reliance, London, England: Earthscan Publications, 320.
  - [2] Reeves, T. (1998) Sustainable Intensification of Agriculture. CIMMYT. Apdo. Postal 6-641, 06600 Mexico. [online] Available: <http://www.cimmyt.cgiar.org/whatisimmy/Sustint.htm>
  - [3] Rodriguez, Lylian and John Kornerup Bang (1999) Capacity Building for Sustainable Rural Development: Education, a Priority. Proceedings of a Workshop March 22–26, 1999 Tune Landboskole Denmark Organizer: The Danish Agricultural and Rural Development Advisers' Forum [Online] Available <http://www.husdyr.kvl.dk/php/tune99/27-Rodrigues.htm>
  - [4] Rogers, A (1996). Participatory Training: Using Critical Reflection On Experience in Agricultural Extension Training. FAO Training for Agriculture and Rural Development, Economic and Social Development Series, No. 54. Smith, Nicholas (undated) Seminar Review: No. 7 Sustainable Agriculture - Myth of Reality? [online] Available : <http://www.science.plym.ac.uk/departments/geography/ggy384/susagr2.htm>
  - [5] The World Bank (1999) World Development Report 1998/99: Knowledge for Development-Summary. The International Bank for Reconstruction and Development. 1818H Street, N.W. Washington D.C. U.S.A.
- 
-

## Rural Knowledge Centres: Thrust of the Farmers

T. Ahmed, M. A. Ansari and I. Prabhakar  
G.B.Pant University of Agriculture and  
Technology, Pantnagar 263145,  
Uttarakhand, INDIA

**Abstract.** Global scenario at the end of the 20<sup>th</sup> century indicates that we are in a great period of change and agriculture is no exception to this. Agriculture is the back bone of India, wherein around 65-70 per cent of the population is dependent on agriculture for their livelihood and provides employment to 52% of countries work force. In contract, the contribution of agriculture to the Grass Domestic Product (GDP) was 54.5% in 1950-51 and is reduced to 18.5% in 2007-2008. The sector Agriculture accounts for about 10.3 % of the total export and about 2.5 % of the total import (Prathiyogita darpan-2008).

Presently worldwide, the agricultural sector is faced with several serious challenges namely; the spiraling demand of food, declining cultivated area due to population pressure, declining agricultural productivity due to natural resources degradation, and increasing competition in international markets. One fundamental element in meeting these challenges is increasing production per unit area by adoption of improved agricultural production technologies and marketing techniques and technologies by farmers and other concerned entrepreneurs.

This calls for transition from 'resources based' to 'technology based' system of agriculture. This transition however places greater responsibility on the agricultural extension sector, since it is a vital channel of new agricultural information and technologies to farmers as well as back to research and policy forum government have traditionally taken the dominant role in the provision of agriculture extension services because of the important contribution the agricultural sector makes to economy.

It is also important to address the need for demand driven and value added information, which is time and location specific. There is also need for technology enablers on local agro-ecological and socio-cultural conditions of each village, and also relating to various farming methods and techniques. Information on the

health status of livestock and poultry, on-farm and off-farm livelihoods and market-led entrepreneurship opportunities for the poor and the marginalised in rural India need attention. There is also need for promoting functional literacy among the adult illiterate and making learning joyful for the young through interactive pedagogic methodologies. So all the above thrust of the farmers can be fulfilled effectively through a network of Rural Knowledge Centre's (RKC) across the country by harnessing the power of ICT in the knowledge, skill, economic and social empowerment of rural families based on the principle of reaching the unreached.

### Effective utilization of Rural Knowledge Centres

- It should be people-centered approach based on community ownership.
- It must take into account the local context and the information needs of the local people/farmers. Then only it can provide useful demand-driven services to farmers. Although we may use a variety of technologies in gathering and reaching the information, the Centres, is not meant to demonstrate the power of technology.
- The Rural Knowledge Centres should be inclusive and not be associated with one group or caste; it should allow everyone to take part.
- The ICT enabled Knowledge Centre should be located in a public space, say in a village school or Panchayat building, to ensure social inclusion in access.
- The principles of social inclusion, gender equity, reaching remote areas should be built in the design of the RKC.

### Approach for setting up of RKC: Mobilization and Need Assessment

Before setting up of these RKC, the staff and volunteers of the implementing agency should get accepted by the people. Unless the local people accept the implementing agency and are ready to work with them, the RKC cannot take off. The people should be ready to work with them. Once the implementing team establishes a good rapport with a wide cross section of the local community, it should carry out large scale consultations with the local people. Information needs of the community and the people's familiarity with different technologies and communication channels should be assessed

through different need analysis methods like opinion leader interview, focus group discussion, or different PRA methods. Implementing agency should collect information on district and village profiles, household details, economic activity of the village, maps, existing infrastructure like govt. institutions, primary health centres, educational institutions, libraries, extension centres, etc. Implementing agency should also collect information on information flow among different players in the rural community, profiles of underprivileged communities, market information, details of artisans and small merchants, problems of landless laborers and local interaction patterns.

### **Local people's participation**

People's participation is vital in all rural, community-based projects. They are the prime movers in the community. People's participation should be broad based and representative, and cut across social and economic status. Local Peoples participation should start from the conceptualization stage and be sustained throughout. Conscious efforts should be put in to build multi-stakeholder partnerships.

### **Connectivity**

The most feasible and cost-effective system should be used. Connectivity and Content should receive concurrent attention of RKC's. But these are not enough. They should be used to satisfy the local communities. Adequate technical skills are required for ensuring/maintaining a robust connectivity infrastructure. Internet technologies offer new options to provide cheaper and more flexible services. The approach should be based on the principle that there is a solution that can be implemented for every problem. One should assess the various available technology options for the last mile and the first mile (wireless, satellite, etc), and implement those that are cost-effective and reliable. Also, one should be alert to new technologies that are being developed all the time, and often these are less expensive and far more efficient than older technologies.

### **Content: Selection and design**

Creation and updating of relevant content to suit local needs is a key factor in the RKC establishment. The information provided should

be demand driven and should be relevant to the day-to-day life and work of rural women and men. Also, semi-literate women should be accorded priority in training to operate the centre, since this is an effective method of enhancing the self-esteem and social prestige of women living in poverty. Packaging of appropriate content (e.g., in local languages) for specific community needs and choices is an important activity of the centre. Content should be delivered in both conventional and electronic means. Merely providing information is not enough. Knowledge dissemination should be linked to access to the inputs needed to apply the knowledge for economic activities. One has to be strategic in generating or procuring content in view of the potentially high cost involved. Equally important as understanding the content is to make the appropriate action based on the information provided. It is also important to address the need for demand driven and value added information that is time and location specific. There is also need for knowledge transfers between and across rural communities, scientists, educators, administrators, health care providers, technology enablers on local agro-ecological and socio-cultural conditions of each village, and also relating to various farming methods and techniques.

### **Management, Monitoring and Evaluation**

Implementing agency should form a management committee consisting of several experts, representatives from NGOs and members from the rural community. This committee will review the centres periodically. Involving youth in the management of the RKC's and decision-making is very important. Managers should be familiar with the technology, willing to learn and have an interest in the needs of the community. It is important to identify young volunteers with leadership qualities and good communication skills to be the link with the community and set into motion an interactive two-way process of information sharing; more importantly, these volunteers should enjoy the confidence of the community. The implementing agency should conduct periodic impact assessment based on surveys, and establish a virtual network of policy makers, researchers, educators, service providers.



### Provision of Services

RKCs will act as multipurpose centres. Which providers varied services advisory services, diagnostic services, input supply services etc. The following are the services which can be provided through RKC

- Marketing information
- Facilitating access to land records/online registration
- Question-and-answer service
- Information about rural development programmes and subsidies
- Weather forecasting
- Latest (best) packages of practices
- Post-harvest technology
- General agricultural news
- Information on crop insurance
- Farm business and management information
- Input prices and availability
- Early warning and management of diseases and pests
- Dairying and marketing of milk and milk products
- Accounting and payment
- Soil testing and soil sampling information
- Goal commitment
- Correlates of frequency of use of information services

### Collaboration

In every programme, harnessing the power of partnerships is very important. It is only through partnership RKCs can bridge the gap between “Scientific know-how” and “Field Level do-how. RKCs will bring more partners regarding agriculture, animal husbandry, education, weather, health, business, law, etc. The second most important ingredient for success of ICT-enabled development programmes is building multi-stakeholder partnerships. If the main function of a Knowledge Centre is to provide authentic and reliable information, the question is, who can provide such information? Often it is the experts working in academic and research institutions and extension centres. It is therefore imperative to forge partnerships with experts – both individuals and institutions. Also, if the development is to be holistic and integrated, we

cannot work in isolation. We have to bring in the expertise and take advantage of the knowledge and skills of a wide range of people and organizations as well as pay heed to the indigenous knowledge and traditional skills of the communities we work with.

### Augmentation

The RKCs will be set up and managed by ICT Self-help Groups / Grassroots institutions (local Panchayats) / Youth Clubs / Farmers Clubs / Fishermen Co-operative Societies comprising both women and men. Capacity building of the above groups and human resource development are essential for success. This will ensure the demand-driven nature of the information provided. Involving local youth in the management of the RKCs and decision-making is very important. Managers should be familiar with the technology, willing to learn and have an interest in the needs of the community.

The RKC has to develop linkages with a range of rural service providers and handle services on behalf of both Government and private sector. Some of these services would be fee-based and generate revenue for the Centre. Collaboration with private sector and industry could be on the pattern of production on contract / franchise / buyback arrangements.

### True sustainability/ withstand ability

Our RKC are on the road to “true sustainability”. While many are championing “business models” for tele-centers, the bottom line being if a tele-centre or radio station makes money, then it is sustainable, there are other priorities, such as social sustainability and the impact on social change. For us sustainability deals with a wider range of issues. RKCs will create long-term, self-sustaining solutions, which reflect local needs and require local initiative and entrepreneurship, so it will fuel the creation of additional local business and community enterprises. RKCs need to be made available in far larger numbers and information exchange must be available at far lower costs if recent ICT advances are to have a significant impact on development for the world’s poorest people.

An interesting application of ICT in strengthening rural livelihood (i.e. income) security is its role in promoting linkages with credit institutions and private sector industry

willing to get products manufactured by rural self-help groups on a franchise loans. This has opened up opportunities for spreading a large set of promising S & T based “franchises” that banks could support through loans. The RKC’s are vital for creating sustainable rural micro-enterprises in the area of agriculture, food processing, animal husbandry, fisheries, sericulture, handicrafts, rural industry and even in IT-based services. RKC’s can be converted into Local Service Providers (LSP) to provide Internet bandwidth for private companies, hospitals, education institutions and individuals with the help of banks and wireless companies. Another option is to link RKC’s with cable.

### **Conclusion**

RKC’s can open a world of information and access to village communities and allow them to provide low-cost services for companies, institutions and individuals. RKC’s can be equipped to train and transform village youths. One should manage content creation, gathering, validation and dissemination, manage technology and connectivity and manage delivery of content on time. Going beyond ICT, content and connectivity, knowledge centres can give a human touch to the whole programme of holistic development. Knowledge Centres should be seen a means cutting across and facilitating development initiatives at the grassroots level.

### **References**

- [1] Agricultural Research & Extension Network, Network Paper No.135 January 2004
  - [2] Jones, G.E. (1997) ‘The history, development and the future of agricultural extension’ in B.E. Swanson, R.P. Bentz and A.J. Sofranko (1997) Improving agricultural extension – a reference manual. Rome: FAO.
  - [3] Swaminathan, M.S. (1993) (ed.) Information technology: Reaching the unreached. Chennai: Macmillan India.
  - [4] Toolkit for setting up Rural Knowledge Centres (RKC), M S Swaminathan Research Foundation
- 
-

## Wireless Sensor Network Technologies: Opportunities and Challenges for Rural India.

S.V. Patel, K. Pandey and V R Rathod  
Veer Narmad South Gujarat University,  
INDIA

patelsv@gmail.com, kamlendup@gmail.com,  
profvrr@hotmail.com

**Abstract.** Convergence of wireless communications, digital electronics and Micro Electro Mechanical Systems (MEMS), has helped the growth of low cost wireless sensor networks. WSN supporting varied applications, is a new interesting platform with characteristics that are quite different from traditional desktop computers and conventional computer networks. Indian rural economy is in development state and it has to meet various challenges. In rural areas, there is an urgent need of deploying feasible, cost effective technologies for their progress and prosperity. WSN is a technology that fits well for applications like environment monitoring, agriculture, health and many more for rural areas. The paper emphasizes the applications and challenges of wireless sensor networks in the problems concerning rural areas.

**Keywords.** Challenges, Opportunities, Rural India, Wireless Sensor Networks

### 1. Introduction

Past few decades have observed exponential growth in computing technologies enabling information processing faster and more efficient. Along with the evolution of computing technology, communication technology has also progressed on a parallel track and it enabled the growth of computer networks. It is now possible to perform computations on information available on any machine on a network from any where.

Recently new set of information that can be processed on quite a different type of network has evolved. If we look at the environment, lot much data is generated continuously. However, unless it is fetched, reformed and put to use it remains as raw data and remains unutilized. Therefore, if we have some mechanism to sense that data, collect and analyze it in automated and

continuous manner, a new set of applications evolve. Of course such data collection, has been done since years, e.g. putting the rain gauges at places, noting the readings and collecting the data for places. However, recently lot of attention is being paid to implement the systems that can continuously collect these data, process them using state of the art technologies in computing and communication at different places i.e using distributed computing and making them available to the applications.

In the present era of converging technologies, Technology convergence of advanced wireless communications, digital electronics and Micro Electro Mechanical Systems (MEMS), has helped the growth of low cost wireless sensor networks. WSN is a new interesting platform with characteristics that are quite different from traditional desktop computers and conventional computer networks. The magazine Business Week identified micro-sensor networking as one of the 21 most important technologies of the 21st century.

A wireless sensor network is a typical network of large number of sensor nodes which are small electronic embedded systems consisting of sensor, processor and radio transceiver. These types of networks are found useful for new classes of applications in various fields like health, agriculture, military, home and many more. WSN can perform data acquisition, data processing and communication on variety of data including of temperature, pressure, light, humidity, radiation, vibrations etc. The sensor nodes can be deployed in large number ( hundreds to thousands ) throughout the area where we would like to monitor specific phenomena. The main advantage of WSN is the ability to be deployed in almost anywhere, where it might not be possible to use traditional networks. Moreover, in line with other technology products, the cost of the wireless sensor technology is also going down and hence making wide spread deployment feasible.

A WSN consists of a large number of sensor nodes, known as motes which are low power, low cost devices consisting of : 1. sensing system that senses environment 2. Processing system to perform computation on the sensed data and 3. Communication system that transmits /receives information to/from other neighbor node. The sensor nodes can be considered as very small computing devices, very basic in terms of their

components. They usually consist of a processing unit with limited computational power, limited memory, sensors, a communication device (usually radio transceivers) and a power source in the form of a battery. As the individual nodes in WSN are resource constrained, they do not have much capacity of processing, however they can become powerful systems when their capabilities are combined i.e. when their network i.e. sensor network is formed.

There is lot of importance of measuring and monitoring of various physical parameters like temperature, pressure, humidity, speed, acceleration, noise, fluid levels, vibration, stress, strain, acidity etc for areas like structural engineering, agriculture and forestry, healthcare, logistics and transportation, home and office automation, military applications and many more. Wired sensor networks have long been used to support such application areas, however, in some areas wireless systems can be considered better alternatives especially for applications that need to measure parameters in inaccessible places like “inside the fuel tank”, “deep inside the machinery”, “large geographical areas” etc where it might not be feasible and cost effective to use conventional networks at all.

## 2. Basic WSN structure

The major components of a typical sensor network are: sensor nodes, the sensor field, the sink node and the task manager.

A sensor field can be considered as the area in which the nodes are placed i.e. the area in which we expect a particular phenomenon to occur. Sensors nodes or motes are the heart of the network. They collect data and route this information to a sink.

A sink is a sensor node with the specific task of receiving, processing and storing data from the other sensor nodes. They serve to reduce the total number of messages that need to be sent, hence reducing the overall energy requirements of the network. Such points are usually assigned dynamically by the network. Regular nodes can also be considered as sinks if they delay outgoing messages until they have aggregated enough sensed information.

The base station is centralized point of control within the network, which extracts information from the network and disseminates control

information back into the network. It also serves as a gateway to other networks, a powerful data processing/ storage centre and an access point for a human interface. Hardware wise the base station is either a laptop or a workstation. Data is streamed to these workstations either via the internet, wireless channels, satellite etc. So hundreds to several thousands nodes are deployed throughout a sensor field to create a wireless multi hop network.

Nodes can use wireless communication media such as infrared, radio, optical media or blue tooth for their communications. The transmission range of the nodes varies according to the communication protocol used.

WSNs can also be described on a higher level as the combination of two different network entities as under:

- The data acquisition network:

The sensor networks measure physical data and the base station collects the information from the nodes and forwards control data to the network environment.

- The data dissemination network:

A wireless sensor network consists of hundreds or thousands of low cost nodes which could either have a fixed location or randomly deployed to monitor the environment. The nodes sense environmental changes and report them to other nodes over a flexible network architecture. Sensors usually communicate with each other using a multi hop approach. The flow of data ends at special nodes called base stations (also referred to as sinks). A base station links the sensor network to another network (like a gateway) to disseminate the data sensed for further processing. Base stations have enhanced capabilities over simple sensor nodes since they must do complex data processing; this justifies the fact that bases stations have workstation/laptop class processors, and of course enough memory, energy, storage and computational power to perform their tasks well.

### 2.1 Hardware

#### a) Sensor Network Components

The basic microcontroller building block consists of memory, processing unit, non volatile memory and interfaces resources such as ADCs, DACs, UARTs, interrupt controllers and counters. Today networked sensors can be constructed using commercial components on the scale of a square inch and a fraction of a watt in

power. They may also use one or more microcontrollers connected to various sensor devices and to small transducer chips.

The main components of sensors consist of a sensing unit, a processing unit, a transceiver, and a power unit.

*b).* Sensing Unit

The main functionality of the sensing unit is to sense or measure physical data from the target area. The analog voltage or signal is generated by the sensor corresponding to the observed phenomenon. It is digitised by an analog-to-digital converter (ADC) and then delivered to the processing unit.

*c)* Processing Unit

The processing unit plays a major role in managing collaboration with other sensors to achieve the predefined tasks. There are currently several families of this unit including microcontrollers, microprocessors etc.

*d)* Transceiver

RF is the most easy to use but requires antenna. Various energy consumption reduction strategies have been developed such as modulation, filtering, and demodulation. The RF Monolithics TR1000 and Chipcon 1000 are examples of radios being used.

*e)* Power Unit

Batteries used in sensors can be categorized into two groups; rechargeable and non-rechargeable. Often in harsh environments, it is impossible to recharge or change a battery. Current sensors are developed to be able to renew their energy from solar/vibration energy. Alkaline/lithium/nickel Metal Hydride batteries are various options.

## 2.2 Software

*a)* Operating system

There are very few operating systems specifically designed for wireless sensor networks. Among them TinyOS is most popular Operating system. TinyOS is based on an event driven model instead of multithreading. Both the TinyOS system and programs written for TinyOS are written in a special programming language called NesC which is an extension to the C programming language.

*b)* Programming languages

Programming the sensor nodes is difficult when compared with normal computer

systems. The resource constrained nature of these nodes gives rise to new programming models. Some of them are c@t (Computation at a point in space (@) Time), DCL (Distributed Compositional Language), galsC, nesC, SNACK, SNAPpy (Python), SCTL

*c)* Algorithms

WSNs are composed of a large number of sensor nodes, therefore, an algorithm for a WSN is implicitly a distributed algorithm. In WSNs the scarcest resource is energy, and one of the most energy-expensive operations are data transmission and idle listening. For this reason, energy saving algorithms are a must.

## 3. Opportunities for WSN applications in rural areas in India

It is an accepted fact that development of infrastructure is a must for the progress any country. Apart from the road, power and water, the need of communication facilities to connect people and places is equally important. India is also on its way to establish rich communication network. The present communication network providing support for landline and mobile devices is expanding rapidly. However, this networks are mainly used for voice communication, limited data communication and have certain limitations in terms of its feasibility for certain applications. These network require typically costly setup of network equipments, communication towers and it still it has limited coverage. The requirement of good power remains the mandatory requirement for these networks.

In the context of rural areas, we advocate need of WSN to be deployed and integrated with the existing communication network. There are lot more opportunities to solve some teething problems of rural areas. To prosper rural areas bellow we provide some candidate applications that may use WSN.

### 3.1 Environmental Applications

Sensor networks can be used to monitor environmental changes. E.g water pollution due to chemical substances, air pollution, humidity

changes in the atmosphere, rainfall measurements, atmospheric temperature etc. Environmental applications are feasible such as tracking the movements of birds, insects and small animals; monitoring environment conditions that affect crop and livestock, irrigation, precision agriculture, biological, earth and environment monitoring in marine, soil, atmospheric context, forest fire detection, meteorological or geophysical research, flood detection, bio-complexity mapping of the environment and pollution study, large scale Earth monitoring and planetary exploration.

For prosperity of our rural areas, there is a strong need of developing certain applications to support agriculture, irrigation and environmental monitoring.

### 3.1.1 Agriculture

Our agriculture crops, land and water in various parts of the country face different problems especially due to the use of various pesticides and due to pollutants. The effects are noted only after we have observed the failure of the crop. There is a requirement that such phenomenon is noticed in time and that too in automated manner. The solution is the deployment of sensor networks, which can continuously sense such parameters and provide timely information to the concerned authorities. Cost effective nodes forming wireless sensor can be deployed in a large geographical area, which continuously sense the parameters and forward the useful data to gateway. The monitoring station running respective software can provide warnings to the concerned authorities like agriculture development authorities to initiate appropriate action.

Similarly the WSN can be used for sensing moisture in the land and provide timely information predicting the need of irrigation water. The information received and analysed in advance can help timely supply of water for the crop. This can even be useful to save water by not supplying water where there is sufficient moisture level in the land. This application offers excellent opportunity for our country as we have limited water for irrigation. In addition to the above parameters, measurement of humidity, temperature, rainfall data can be helpful to the decision support system.

### 3.1.2 Soil Management

The soil is the most important resource for agriculture. The type of mineral ions present in the root zone determine the type of crop and the amount of fertilizer supplement to be given. The ionic or chemical sensors can be deployed in the soil to sense the chemical composition. The sensed data is interpreted in terms of fertilizer demand. This will optimize the use of fertilizer and help the farmers to select the crops. Figure 1 shows a typical sensor network.

### 3.2 Forest Fire Detection

WSNs may be deployed randomly and densely in a forest. These sensor nodes can transmit the source of the fire to the fire rescue team or fire fighting department before the fire is expanded over other region. Since these sensor networks may be unattended for large periods, efficient energy saving mechanisms and solar cell technologies may be used. The sensors perform distributed collaboration and overcome obstacles such as trees and rocks that block the line of sight of sensor. Our country needs to save forests and hence if such systems are deployed they can help to save an important and costly resource.

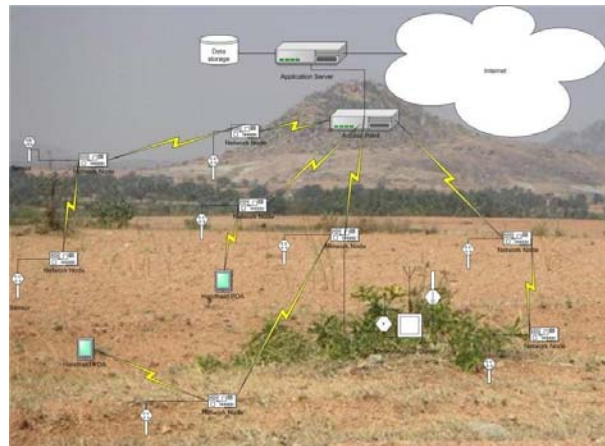


Fig 1: Wireless sensor network

### 3.3 Flood Detection

Various parts of our country come under threats due to floods. WSN is an excellent technology which can warn well in advance and in automated fashion. The idea is deployment of various sensor nodes well spread across catchment areas of rivers or river basins which in turn can continuously collect water level as well as rainfall measurements and pass the data

through wireless networks to the control station. It is obvious that wired solutions are not at all suitable for such applications.

Such flood detection is ALERT system which is deployed in the US. Rainfalls, water level, weather sensors are used in this system to detect, predict and hence prevent floods.

### 3.4 Habitat Monitoring Applications

If one wish to monitor plant and animal species populations and activities, WSN can be helpful. The primary modalities are video (imaging) and audio (acoustics) to track species or phenomena based on sound, or video information.

Sensor networks are being deployed in natural parks and wildlife reserves to closely monitor and aggregate data from animal and plant life. Earlier methods of field monitoring were error prone, tedious and potentially dangerous to plant and animal life. Data gathered from these networks can be studied and useful information such as nesting patterns, flowering seasons, effects of different micro-environments etc can be inferred.

Our Gir forests and other forests are in urgent need of such deployments which ultimately help in preserving our treasure of such animals. Similar is the utility of such networks for other species like Dolphin in Ganga river.

### 3.5 Health Applications

Healthcare: Sensors can be implanted in the human body to monitor medical problems like cancer and help patients maintain their health.

Our rural areas have acute shortage of hospitals and doctors. The timely diagnosis and treatment is the basic necessity for our rural areas.

WSNs can be used to collect and store the physiological variables such as blood pressure, heart rate, etc. of the patients for a long period of time. Wearable and implantable sensors can monitor a broad variety of conditions of the patients continuously at all times. Doctors can monitor these data remotely for medical examination through the use of WSNs. Even in the hospital, tiny sensor nodes of WSN can be attached to each patient to do their assigned tasks such as measuring heart rate, blood pressure and brain activities at different times. This system can be helpful in rural hospitals where monitoring can done with the help of less

doctors. Tele monitoring may also enable testing and commencement of treatment in remote locations, as well as assisting in the precise location of accident or disaster sites.

#### 3.5.1 Drug Administration in Hospitals

The chance of getting and prescribing the wrong medication to patients can be minimized. If sensor nodes can be attached to medications and patients have sensor nodes that identify their allergies and required medications.

Some other similar applications include Glucose level monitors, Organ monitors, Cancer detectors and General health monitors.

### 3.6 Other Applications

#### 3.6.1 Structure Health Monitoring(SHM) System

SHM is another important domain for sensor network application. The goals include detecting damage, localizing damage, estimating the extent of the damage and predicting the residual life of the structure. SHM using WSN is an evolving technology and promising. This is a very promising application for our rural areas as our old bridge structures and old buildings are prone to failures/ accidents and we have witnessed many incidents that have caused damage to property as well as human lives. It is therefore recommended that Sensor networks be used to detect distortion and structural problems in all such structures in order to prevent disasters.

#### 3.6.2 Disaster relief

Our country faces many disasters incidents occurring in rural areas. Present systems of disaster relief are in-efficient. WSNs can be used to map the disaster area. They can be efficiently used to direct the nearest emergency rescue teams to affected sites if sensors are densely scattered over a targeted area. Even if some of these sensors are destroyed due to their location in the disaster area itself, the remaining sensors coordinate their duties and help rescue team to find safe evacuation paths.

## 4. Challenges

Though there are large number of applications of WSN, there are certain challenges in implementing a WSN in rural areas stated bellow:

### 4.1 Power requirements

For WSN nodes this will not be a problem as they may be equipped with the solar cells. However for WSN gateways this could be the potential problem that needs to be solved. If the village has electricity, then the network may be such designed that gateways are placed at village panchayat places where sufficient power is available. In some cases we may need large solar panels to make the supply available which could be a challenge.

#### 4.2 Coverage and Cost effectiveness

This is a challenging task and at present the cost is not feasible. However as technology is advancing, wsn will become cheaper to enable large number of nodes to be deployed to cater for the need of the applications.

At present the development work to provide user friendly software for WSN is in development stage. Further, as the stack holders of the applications are rural people, we may require user friendly software that communicates in local languages.

### 5. Conclusion

The paper described the WSN technologies in detail and explored its role in various problem areas of rural population in our country. Our rural areas are in urgent need of some applications like environmental, habitat monitoring, medicare, disaster relief etc for which WSN offers good opportunities. We also highlighted some challenges that may be faced in WSN implementations. However, the solutions to the problems is only a matter of time. It is therefore expected that , days are not far for WSN to reach our rural areas.

### References

- [1] "Ideas for the 21st century," Business Week, pp. 78–167, Aug. 30, 1999.
- [2] A. Cerpa, J. Elson, D. Estrin, L. Girod, M. Hamilton, and J. Zhao. Habitat monitoring: Application driver for wireless communications technology. In Proceedings of the 2001 ACM SIGCOMM Workshop on Data Communications in Latin America and the Caribbean, April 2001., 2001.
- [3] A. Rytter. Vibration based inspection of civil engineering structures, ph. d. dissertation, dept. of building technology and structural eng., aalborg univ., denmark. 1993.
- [4] Britton, M. et al. The SECOAS project: Development of a self organizing, wireless sensor network for environmental monitoring. Proc. workshop SANPA, 2004.
- [5] Chaudhary, S. et al. Architecture of Sensor based Agricultural Information System for Effective Planning of Farm Activities. Proc. SCC, 2004.
- [6] F.L. Lewis et al, Wireless sensor networks, Smart environments: Technologies, Protocols, and applications, John Wiley, New York, 2004
- [7] Holmquist, L.E. et al. Building Intelligent Environments with Smart-Its. IEEE Computer Graphics and Applications, vol.24 No.1, pp. 56-64, 2004.
- [8] [http://en.wikipedia.org/wiki/Wireless sensor network](http://en.wikipedia.org/wiki/Wireless_sensor_network)
- [9] <http://www.alertsystems.org>
- [10] <http://www.tinyos.net>
- [11] <http://www.xbow.com>
- [12] I. Akyildiz, W. Su, Y. Sankarasubramaniam, and E. Cayirci, "A survey on sensor networks," IEEE Communication Magazine, Aug. 2002.
- [13] J. Feng, F. Koushanfar, and M. Potkonjak, "System-Architecture for Sensor Networks Issues, Alternatives, and Directions," ICCD'02, 2002.
- [14] Jason Lester Hill, "System Architecture for Wireless Sensor Network," PhD Dissertation, University of California, Berkeley, 2003.
- [15] M.A.M. Vieira, C.N. Coelho. Jr., D.C. da Silva Jr., and J.M. da Mata, "Survey on Wireless Sensor Network Devices," IEEE, 2003.
- [16] Martinez, K. et al. Environmental Sensor Networks. IEEE Computer, Vol. 37, No. 8, pp. 50-56, 2004.
- [17] Marco Zennaro, Antoine Bagula, Bjorn Pehrson, Wireless sensor networks: A great opportunity for researchers in developing countries, 2nd international symposium on wireless communications and information technology in developing countries, 2008
- [18] P. Johnson et al., Remote continuous physiological monitoring in the home, Journal of Telemed Telecare 2 (2) (1996) 107–113. 420 I.F. Akyildiz et al. / Computer Networks 38 (2002) 393–422



- [19] Shum, L. et al. Distributed Algorithm Implementation and Interaction in Wireless Sensor Networks. Proc. Workshop SANPA, 2004.
- [20] Szewczyk, R. et al. An analysis of a large scale habitat monitoring application. Proc. SenSys, pp. 214 - 226, 2004.
- 
- 

## **Three AMAZING Teaching Aids: Singing Cup, Gyroscope and Auto- Returning Airplane**

T. Cheng-Ming  
t401201@yahoo.com.tw

### **A. Singing Cup**

#### **Related scientific concepts:**

**rubbing, standing wave, loudness, tone  
and timbre.**

Wash your hands and singing cup with soap, the purpose for this step is to remove all the impurities, in case of any impurities obstruct generating “standing waves”. keep your hands and singing cup wet and use your strength to hold the cup bottom (do not hold the cup body) with one hand, and use your point finger of the other hand to rub the edge of singing cup “continuously and with strength”, and the singing cup will have resounding and continuously sound.

The cultural meaning of singing cup: In ancient China, singing cup was called “lucky cup” which means people who own this kind of cup are lucky and happiness. Singing cup is made by professional tea cup makers. The requirements of angle and thickness are very precise and the burning temperature must be controlled appropriate. One lucky cup was selected maybe from more than ten thousands of cups, that’s the reason of the kings and royalties treated it as treasure. However, singing cups are common gradually because of development of modern technology.

### **B. Gyroscope**

#### **Related scientific concepts:**

**gyroscope, angular momentum,  
orientation, navigation.**

Gyroscope—in adult’s world, it could orientate, aseismatic, navigate...etc, how about in children’s world, how do they play gyroscope? Such as gyroscope pyramid, rotating oriented, rotating indirectly, rotating on a rope, rotating on a piece of paper money, rotating on a finger and pen, radar gyroscope...etc.

### C. Auto-returning toy airplane

#### Related scientific concepts:

#### Bernoulli principle and lift force.

This is for teaching of making and operating an "Auto-returning airplane" by yourself., there are 5 steps of making airplane: Making framework of airplane, making main wing, making tail and vertical wing, assembling the airplane...etc.

Method of operating is quite easy as following: Take the centre of gravity of the airplane, and throw it out by single-handed backhand of tennis and the angle is like the airplane makes a turn in the sky. The airplane will return to your hand automatically after flying one lap!

To make it more interesting, the competition could be played by group or individual. If you would like to play the game by group, you could form 3-6 people as a group, and everyone throws the airplane once, and if the flight diameter is more than 3 meters, and the airplane will return to the person who threw it out, this person will gain one point, and the group gain more scores than others win.

---

---

### Importance of Pyrimidine Derivatives in Day-to-Day Life

S. Das and A.J. Thakur

Department of Chemical Sciences, Central  
University, Tezpur, Napaam-INDIA  
ashim@tezu.ernet.in

**Abstract.** Heterocycles constitute the lion's part of organic chemistry and are of immense importance biologically, industrially and indeed to the healthy and wealthy functioning of any developed society/nation. Importantly, the majority of pharmaceuticals / biologically significant / agrochemicals / commercially used / available molecules are heterocycles, as are countless additives and modifiers used in industries as varied as cosmetics, reprography, information storage and plastics. They are of plant as well as animal origin and available in DNA-RNA base, vitamins, enzymes, hormones etc. Importantly is the recognition that heterocycle can play a vital role not only as goals of synthesis, but also as mediators in synthetic transformation. They also find honourable position in inorganic chemistry (e.g. as ligands, etc.), materials science too. Specially, nitrogenous heterocyclic compounds are basic constituents of alkaloids. These natural products have given birth to several smaller units, which are highly important to the present day's life quality as well as commerce. Pyrimidines represents one of the most important nitrogenous heterocyclic aromatic compound similar to benzene and pyridine, containing two nitrogen atoms at position 1 and 3 of the six-member ring. These pyrimidine units, annealed with a variety of ring systems are available in natural sources, like nucleoside and nucleotides etc. Three nucleobases found in nucleic acids, namely cytosine, thymine and uracil are pyrimidine derivatives. Pyrimidine nucleotides play a key role in DNA and RNA synthesis, in the activation of sugar as a prerequisite for glycosylation of proteins and lipids, polysaccharide synthesis and detoxification. In DNA and RNA, these bases form hydrogen bonds with their complementary purines. E.g. purine bases adenine (A) and guanine (G) pair up with the pyrimidines thymine (T) and cytosine (C) respectively. Pyrimidine, fused pyrimidine and its derivatives have received considerable attention over the past years due to their wide

range of biological activities. Many drug candidates have been modelled on these compounds, particularly for cancer and virus research. Pyrimidine derivatives are found as non nucleoside adenosine kinase inhibitors, selective Adenosine A1 receptor antagonists, Dihydrofolate reductase (DHFR) inhibitor, human gonadotropin releasing hormone receptor antagonists, anti-hepatitis C virus active, estrogen receptor antagonists, chemotherapy, immunosuppression, viral infections and parasitic diseases etc. While the development of clinically useful anticancer (5-fluorouracil) and antiviral drugs (AZT, DDC, DDI, BVDU) has renewed interest in the synthetic manipulation of uracils. A number of methods for construction of fused pyrimidine molecules are available in the literature. Among those Diels-Alder Reaction (DAR) is firmly entrenched as one of the most versatile and powerful synthetic transformations in organic chemistry for regio- and stereospecific construction of carbocyclic and heterocyclic six-membered ring systems as a result of interplay between a diene (4<sup>o</sup> -component) and dienophile (2<sup>o</sup> -component). Recently, green procedure for the synthesis of pyrimidine derivatives using Diels-Alder reaction as the standard method has been gaining popularity. Among them, reaction in water, ionic liquids and microwave irradiation enjoy wide popularity.

---

---

## How Relevant Are Our Urban Science Centres in Today's Societies?

R. Mehrotra

Kurukshetra Panorama & Science Centre,  
Kurukshetra-INDIA  
kpsckkr01@refmail.com

**Abstract.** The new communications technologies popularized in the last decade—from the Internet to cell phones to iPods—are transforming our world. They are fundamentally altering the way we access information and how we interact with one another. Today, thanks to new applications of these technologies and to pervasive low-cost broadband access in the home, we are able to easily find information about almost any topic from almost anywhere in the world. Blogs, podcasts and other social networking technologies are enhancing interaction among individuals—enabling people from widely diverse backgrounds to share their opinions and their expertise with thousands of others. Since its public debut in the early 1990s, the Internet has become the source for instant, up-to-date information. Today, the public has become more and more accustomed to having the Internet available wherever and whenever they want it and carrying a heavy laptop is no longer a requirement for net connectivity; more and more mobile phones can access the Internet. New technologies are not merely transforming where and when we are able to access information, but also the types of information we receive. The technology is transforming our economy as well. Thus with the massive growth & use of the web format, a massive challenge has emerged both within the walls of the science museum institutions and outside them, for educators and curators, at the heart of which lie the questions – exclusively in the urban settings, what is distinctive about learning in museums, science centres and galleries, and how might this change or evolve through the increasing use of digital technologies? How the “Click-for-information” savvy society of urban environment responds towards the Science Centres which are considered as major hubs of non - formal science education. These questions go to the heart of significant debates in this sector – how does learning in museums differ from or complement

learning in schools? How can museums fulfil their potential to support lifelong learning? Should effort and money be spent primarily on the visitors who will enter the walls of the institution or those who will virtually explore the site through the web? What is the role of objects in the process of learning with digital technologies? How does the relationship between museum educator and learner change as technologies are developed? At a time when there are calls for collaboration between schools and the informal learning sector, when there is increasing emphasis on lifelong learning, when there is significant debate over the value and utility of digital resources, this study takes a step back and asks us to consider the bigger picture – the history and role of learning in museums, science centres and galleries, the theories that can help us to navigate the as yet unclear waters of the future, and the major projects and initiatives that are already providing indications of the routes we might take. Despite today's fast growing society use of websites and interest in technology and multimedia the relevance for Science Centres can not be undermined. The strongest reason is the difference in approach that Science Centres take in educating public. A learning process has to be entertaining without sacrificing the educational component to provoke and maintain curiosity and engagement. The environment of Science Centre displays and processes such concepts so that the outcomes are delivered in the form of a 'Total Experience' that is unique for each visitor. An important form of learning is that individuals construct their own notions of new knowledge on the basis of their existing information base. Learning is an active process in which the learner has to actively construct his knowledge on the basis of the conception already present in the learner's cognitive structure. The environment of the Science Centre strongly supports this learning form. Science Centres offer a variety of opportunities to participate in educational processes and experiences. This may range from a cursory visit to at-home activities that make learning of science fun and rewarding both in terms of understanding scientific concept and interest development. This is because learning in the free-choice learning environments is similar to learning in one's own cultural environment through hands on apprenticeship, not through didactic presentations. The exhibits and activities

here foster curiosity and creativity at one's own pace. Science Centres in India have significant intellectual physical and emotional impacts on their visitors. Such impacts are enhanced by social interaction largely depending on exhibit characteristics. Since impacts are also environmentally influenced and enhanced, concrete experimental activities reinforce concept development and learning due to efficient communication techniques and unique learning environment. The urban Science Centres play up pivotal role in creating public and private use of urban spaces manifesting to be a meeting point for socially diverge communities. The urban Science Centre describes the social tasks the city must provide to its population. Also, Science Centres provides spaces that are inclusive for everybody and act as enlightening medium for the communication between the hegemonic urban elite and the democratic subcultures in the city. A spectacular and now-a-days most post modern architecture of urban Science Centres manifest attraction for residents and tourist, helping to vitalize or revitalize urban life at their location. Orientation and spatial identity to an area is provided by urban Science Centres which also act as symbol for modern economic liveliness.

---

---

## Promotion of Scientific and Technological Temper Empowering India by creating Scientific & Technological Ambiance

L.K. Chhaya

Nirma University, Ahmedabad, INDIA

lipi.chhaya@nirmauni.ac.in,

lipi\_chhaya@yahoo.co.in

**Abstract.** Science has several rewards as inventions are the result of diligent efforts. As Adam Smith has rightly said, "Science is the great antidote to the poison of enthusiasm and superstition." Science and technology has the ability to herald a revolution in terms of social, economical and intellectual. Science is the best art produced in the last century. Science education has an important role to play in the cultural and social development of human kind and for evolving a civilized society. The essence of scientific spirit is to think globally and work at a grass root level. Since scientific knowledge is universal in nature, promotion of scientific temper has become an essential matter for empowering India. Looking into the past, we can see all of the beneficial advancements we have made and how far we have come. Science and technology will continue to benefit society because there will always be new problems popping up over time that will need something bigger, better or a new cure for. Education is the base for scientific and technological advancements and personnel training of human beings. In the midst of overall concern of the rejuvenation drive, Education especially Science Education must get a strategic priority. The Founders of the Indian Republic gave a great importance to the nurturing of "Scientific Temper" among the society of this country by suitably incorporating it in our constitution. Though the country today can claim in various spheres like atomic energy, space, telecommunication and information technology, it is a matter of regret that the Scientific temper among the society, more so with the educated civic has not progressed to the desirable extent. As scientific inventions gave birth to innovative technologies, continuous efforts should be made by the government and all of us who are educated and civilized and can contribute their best in the promotion of scientific temper.

**Keywords:** CSIR, DECU, ICT, rain water harvesting, renewable energy sources, scientific temper, Telemedicine.

### Introduction

The word Science is from the Latin word *scientia*, meaning "knowledge" refers in its broadest sense to any systematic knowledge-base or prescriptive practice that is capable of resulting in a prediction or predictable type of outcome. The role of Science & Technology is of exceptional importance keeping in mind the economic and social importance. Scientific temper deals with what one sees, thinks and feels in reality or conceptually seeking the fact in real sense. One who can imagine can create. Scientific temper deals with imagination and creativity to find the reality. Acceptance of scientific temper is a passion to search for the reality. Promoting scientific temper of citizens is about bringing a fundamental change in their way of thinking, enabling them to question, analyze and reason better in all aspects of their everyday lives, making the scientific method a part of it.

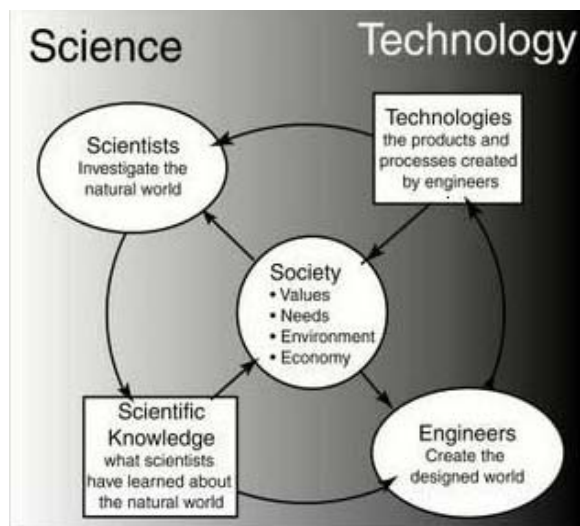


Figure 1. Science and society

Fig.1 shows the importance of science and technology in society. The necessity of harnessing science and technology for transforming India has long been recognized. According to article 51A in chapter iv(a) in constitution of India, it is a duty of every Indian citizen to develop the scientific temper, humanism and the spirit of inquiry and reform;

In fact, Mahatma Gandhi had clearly shown an appreciation of this as necessity. As early as 1935, at the All India Village Industries Association, Mahatma Gandhi initiated a movement called 'Science for People', with an advisory board of national personalities including scientists like J. C. Bose, P. C. Ray and C. V. Raman. By promoting the scientific and technological temper, we can emerge as a progressive and enlightened society, and can make it possible for all our people to participate fully in the development of science and technology and its application for human welfare.

### **Pre independence scenario**

In ancient India, Maharshi Sushruta is the father of surgery. 2600 years ago he and scientists of his time conducted complicated surgeries like caesareans, cataract, artificial limbs, fractures, urinary stones and even plastic surgery. Usage of anaesthesia was well known in ancient India. Over 125 surgical equipments were used. Detailed knowledge of anatomy, physiology, aetiology, embryology, digestion, metabolism, genetics and immunity is also found in many texts. Before India became independent on August 15, 1947, science policy, if any, was determined entirely by the British government. There was no apparent, well-defined policy at that time, except that science and technology were not considered important elements in the development of India. There were few scientific institutions, and no obvious attempt was made to increase the scientific content of educational institutions or to create institutional structures and agencies devoted to science and technology. The only significant science agency was the Council of Scientific and Industrial Research (CSIR), established in 1942. There were, however, some leading scientists in pre-independent India. Important examples are: J.C. Bose (1858–1937), who invented radio wave propagation in 1905; C.V. Raman (1888–1970), who discovered the Raman Effect; S.N. Bose (1894–1974), who developed the famous Bose–Einstein statistics; and M.N. Saha (1893–1956), who worked on stellar physics. Two major scientific research institutions existed then: the Indian Institute of Science in Bangalore, and the Indian Association for the Cultivation of Science in Kolkata. The Indian National Congress, which

was primarily responsible for carrying out the struggle for freedom, considered science to be an important element in India's future, and it deliberated on issues related to science and national development. The Congress Party developed its own science policy even before the first government of independent India was formed in August 1947. The Indian Institute of Science, the premier scientific research institution of India, was established from a donation made by the great Indian industrialist, JRD Tata, who approached the then Viceroy of India to establish a scientific research institution. Although the first three universities in the country—the University of Calcutta, the University of Bombay, and the University of Madras were established in 1857, their principal objective was to train subordinate personnel for colonial civil service, and the three offered very few scientific courses. The Viceroy referred this matter to the Royal Society of London, which formed a committee for the purpose. The committee recommended that such an institution was needed in India and made it possible to set up the Indian Institute of Science in Bangalore in 1909. In 1933, C.V. Raman became the first Indian president of the institute, and served as professor of physics until 1948. The Indian Association for the Cultivation of Science was established by a great Bengali, Mahendralal Sirkar, in Calcutta. Sirkar, a physician and founder-editor of the Calcutta Journal of Medicine, wanted to establish an institution where Indians could conduct research in facilities comparable to those of England. Because he saw the association as a key to genuine independence, he insisted that it should be established and supported entirely by the Indian community. Although little used, this institution caught the attention of C.V. Raman, a finance officer of the British government in Kolkata. This led to the invention of the Raman Effect, and Raman received the Nobel Prize for this discovery in 1930. The Tata Institute of Fundamental Research in Mumbai was founded in 1945 by Homi Bhabha (1909–1966) with a donation from the Tata Trust. The atomic energy programme had its birth in this institute.

## Post independence scenario

After independence, under the leadership of Pandit Jawaharlal Nehru, the first Prime Minister of India, the national government made science an integral part of India's development. His vision for India's future depended heavily on the contribution of science to eradicate poverty and solve the many problems facing young India. His science policy resolution, proposed to parliament in 1958, is a landmark in the history of India. The essence of the resolution affirms the government's intent to support science and technology in order to secure for the people of the country all the benefits that can accrue from the acquisition and application of scientific knowledge. National Physical Laboratory was established in Delhi in 1947. It is at this Laboratory an inscription bears the words of Louis Pasteur: "Take interest, I implore you in the sacred dwellings which one designates by the expressive term, laboratories. Demand that they be multiplied and advanced. These are the temples of the future. There it is that humanity grows greater, stronger, better." After that the Atomic Energy Commission was set up in August 1948. It became full-fledged Department of Atomic Energy (DAE) in 1954 under Homi Jehangir Bhabha. The first nuclear power station at Tarapur started generating power in October 1969. Two such centers came at Kota in Rajasthan and Kalpakkam near Chennai in Tamil Nadu. The fourth one was set up at Narora in Uttar Pradesh. Besides the availability of Hydro-electric power, these centers generate power which is very essential for industrial development. India carried out peaceful nuclear explosions at Pokhran in Rajasthan on 18th May, 1974 and 11th May, 1998. Council of Scientific and Industrial Space research has made appreciable progress in India. Dr. Vikram A. Sarabhai expanded the work of the Indian Space Research Organization India's first satellite, Aryabhata, was launched in 1975. India has also launched other satellites Bhaskara I and II. India has launched Satellite Launch Vehicles (SLVs), Augmented Satellite Launch Vehicles (ASLVs), Geo-Synchronous Satellite Launch Vehicle (GSLVs) and Polar Satellite Launch Vehicles (PSLVs). A series of Indian National Satellites (INSATs) launched from 1982 onwards have revolutionized our different fields like television, telecommunication, resource survey and

management, environmental monitoring, meteorological and information technology systems. In Oceanography, Indian scientists have made good progress. Our missile technology has improved due to the contribution of our former president and prominent personality Dr. A.P.J. Abdul Kalam. We have progressed in many fields like food, fuel, fertilizers, physics, electronics, aeronautics, cosmic rays and chemistry. Our scientists have set up a research centre at Antarctica. It is called as the Dakshin Gangotri. In the field of agricultural research M.S. Swaminathan has contributed much for the success of the Green Revolution in India. Nehru's Government appointed a Scientific Manpower Committee in 1947 to assess the technical personnel needed for the country. It led to the establishment of the Indian Institutes of Technology (IITs) at Chennai, Delhi, Kanpur, Karagpur and Mumbai. Later two more have come at Roorkee and Assam. They have produced many trained technologists. India stands third in having trained technologists next to the United States and Russia. Computer engineering is popular in India. There are many computer scientists, engineers, and technocrats in the country.

## Hurdles in the path of science and technology

As Lord Krishna in Bhagvad Gita says, "Agnanena avritam gnanam tena muhyanti jantavaha". It means, it is because of ignorance that man is deluded. There are many challenges which are sought to be handled with Scientific & Technological interventions. There are many hurdles in the path of science and technology like superstitions, poverty, illiteracy and delusions. Over the last 50 years, successive Governments have been committed to achieve the national goal of universal education and have steadily increased the budgetary allocation for education. However, 35 per cent of our adult population is yet to achieve literacy. Science is the study of the physical world and its manifestations, especially by using systematic observation and experiment while superstition is an irrational but usually deep-seated belief in the magical effects of a particular action or ritual, especially in the likelihood that good or bad luck will result from performing it. Superstitious beliefs have retarded human progress from time

immemorial. Swami Vivekananda said that ‘I would rather see every one of you rank atheists than superstitious fools, for the atheist is alive and you can make something out of him. But if superstition enters, the brain is gone, the brain is softening, and degradation has seized upon the life.’ To promote the scientific temper of the society, we have to change attitude and mindset of citizens. Sometimes the circumstances in which they are placed are also responsible for mistaken beliefs. We are also facing the basic problems of energy and water. Farmers in the rural area are not aware about the water to pesticides ratio which results into insufficient and inappropriate crops. Despite some of the visible progress in the field of science and technology, the propagation of some of the society relevant issues like gender equality, population growth is still noticeable. This clearly shows disparity in human development. The biggest challenge is how to minimize the visible gaps in development. With the help of science and technology we can overcome some of these hurdles. We need sustainable development to create scientific and technological ambiance.

### **Implementation strategies in different sectors**

#### **1. Education**

Change in curriculum, Change in Teaching methodology, Internet, Tele education, Printed learning Material, Literacy Campaign, ICT, Awareness programmes by Universities and institutions, Global education, Science clubs, Science Fairs, Science and technology Exhibitions, Science parks, Science cartoons & comics, Mobile library, Industry institution interaction.

#### **2. Healthcare**

Health awareness campaign, food and nutrition awareness, Media, Telefilms, Community FM, Telemedicine.

#### **3. Energy conservation**

Non conventional energy sources like bio mass, Solar Energy, Wind power, Renewable energy sources.

#### **4. Water mission**

Rain water harvesting, Sea water desalination using solar energy, Redistribution of water, Drinking water availability

#### **5. Food and Drug control**

Awareness about quality of food and drugs, Awareness programmes by doctors, Hygienic process of manufacturing and packaging.

#### **6. Pollution control & Environment**

Fuel efficient vehicles, stringent rules and regulations for waste management, Use of non conventional energy sources.

#### **7. Women Empowerment**

Community FM, Night schools, Health awareness campaign, literacy campaign, Computer literacy, Anti superstition campaign, Lectures regarding food and nutrition, Gender equality campaign.

### **Creating scientific and technological ambiance**

It is mentioned in the forth verse of Bhagvad Gita, there is nothing like knowledge which makes us sacred. So, we have to bring out the fire of knowledge to dispel ignorance. We don't have lack of scientists, engineers and science graduates but we have a lack of people with vision. It may be possible that a scientifically and technologically educated person may lack of scientific temper and on the contrary, less educated or arts or commerce graduate person can have more inclination towards science. Scientific temper reflects one's reasonable, cogent, diagnostic and vital thinking. The scientific temper and technique of science depict one's overall persona. With the strong support of government and society, we can promote the scientific temper of society and can empower our nation. According to Dr. Kalam's opinion to promote the scientific temper, "Everything you do, you ask a question, what you are doing scientifically? Also, ask yourself, how you can do it better within the existing resources in the circumstance you are placed? Cultivate this habit among the youth. This will be a good way of promoting scientific culture." To promote the scientific temper of society, we need to change viewpoint of citizens, a paradigm shift. The commercialization of an improved technology in a rural area requires the concurrence of the ultimate user (individual, household or community) of technology. In turn, this concurrence depends upon the potential user understanding the costs and benefits of the



various technological options, knowing about the improved technology and being aware of its relative advantages. A large number of technology users, however, are unaware of the advantages of the technology and of its cost-effectiveness. The obvious way of overcoming this barrier is to provide information in various ways. Whereas door-to-door canvassing, leaflets through the mail, newspapers and magazines are effective in urban areas with literate target audiences. In rural areas, demonstrations must play a key role in addition to radio and television. And, of course, the training of technology users is a powerful way of educating them with regard to the advantages of the technology. Thus, the supply of relevant information and the education of the technology users are the means of overcoming the barrier posed by the uninformed. The curriculum and teaching methodology should be changed. More emphasis should be given to practical knowledge. We should focus on global and state of the art education. We can promote scientific culture through missionary schools, madresa and other religious bodies which provide religious education. Science fairs, science club, science tours, and Science magazines are the effective ways to promote the scientific temper. Only one governing authority should be there for affiliation of institutions. Government should come up with the plans like 'Earn while you learn science' for illiterate citizens. The biggest challenge is a brain drain. We should make efforts to provide job satisfaction to our youth in India so we can utilize their knowledge in a best way. Apart from this, the satellite communication can be a great help for creating homogeneity among the heterogeneous group. The education programme through satellite is started by BISAG to educate rural people. Fig.2 shows that how education can be made available via satellite.

Telemedicine is an important initiative of Department of Science to use space technology for societal benefits. While DOS provides the telemedicine systems with software, hardware and communication equipments as well as satellite bandwidth. The state governments and the specialty hospitals have to allocate funds for their part of infrastructure, manpower and maintenance.

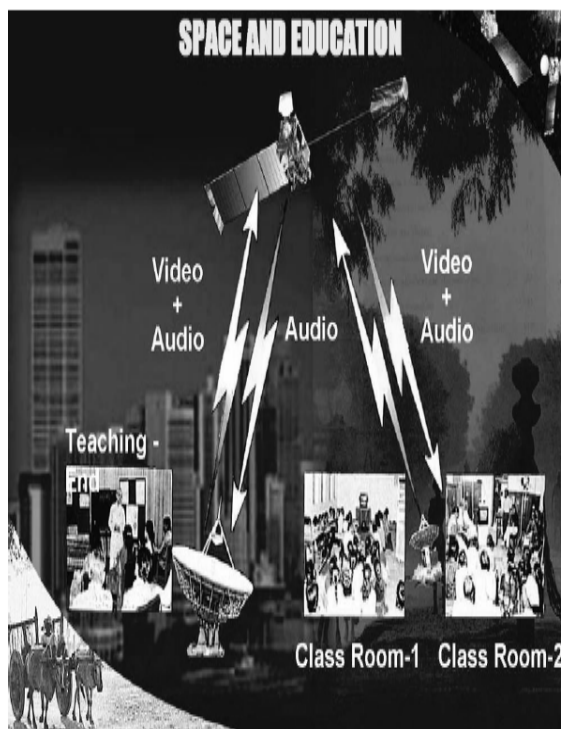


Figure 2. Education through satellite. Source: Catalyst issue-8

Technology development, standards and cost effective systems have been evolved in association with various state governments, NGOs, specialty hospitals and industry. DOS interacts with state government and specialty hospitals for bringing an understanding between the parties through a MOU. DECU in collaboration with NDMA is producing a video programme on role of science and technology in disaster management. These examples show the value of information and services provided by our science and technology community to the society, to the service of our people. The main objective of science communication is to convey scientific information may be adopted by the corporate sector within an overall national mission for education. 540 million youth of our nation can be a driving force to build prosperous India. Apart from utilizing youth, we can also use the experience and knowledge of retired persons from different fields as a source of motivation. Different organizations and institutions can be integrated to design the curriculum based on age group and qualification, which should be a mandatory certificate course to acquire a job in different fields. Industry institution interaction is an effective tool for promoting scientific culture. For science and

engineering students, membership of different associations like IETE, IEEE, ISTE etc. must be made compulsory. Science Park, Science rides, Science films and science fairs are effectual tools to educate children. Doctors and pharmacologists can organize health awareness programmes to educate rural community. Engineers and science graduates can contribute in the areas of technology, science, agriculture, energy and water resources. Water harvesting and use of renewable energy sources can solve the problem of water and energy crisis. Motivation is a key factor for progress so; more number of awards and recognitions must be given to the worthy citizens of our nation. To create the scientific and technological ambiance, the tools like help line, anti superstition campaign, cleanliness campaign, literacy campaign, ICT, street plays, media and entertainment industry, education programmes by universities and institutions, health alertness programmes, advertisements on local TV channels, awareness campaigns by Non government organizations and science communication can be employed. There must be utmost priority for women education. When the women are empowered, a stable society will emerge.

### **Acknowledgement**

With the sense of gratitude and respect, I would like to acknowledge our former president and leading personality Dr. APJ Abdul kalam for his kind response.

### **Conclusions**

Empowerment of India by creating scientific and technological ambiance requires combine efforts of government and society. We have to disseminate scientific knowledge among the community to realize the relevance of science and technology in their daily lives. Scientific temper must be cultivated in our citizens with absolute capacity for decisive evaluation. This step can be easily cultivated in our 540 million young minds so that they will blossom into valuable citizens of this nation. We have to impart scientific temper in the thoughts, actions and deeds of our civilization. Efficient use of existing knowledge can create comprehensive wealth for nation and also improve the quality of life. Our vision should be nurtured and translated

into missions. Our consistent and focused efforts will make India a proud, prosperous and developed country.

### **References**

- [1] Gupta, V., 'Grassroots Science', <http://www.lifepositive.com/Spirit/masters/mahatma-gandhi/gandhian-economics.asp>
  - [2] B. Viswanathan, The relevance of scientific temper among Indians, National Centre for Catalysis Research, Indian Institute of Technology Madras
  - [3] Accelerate Development: Aspiration of the youth, <http://www.abdulkalam.com,2007,Delhi>
  - [4] Krishnaswamy, K. N. and Reddy, A. K. N., The commercialization of improved technologies in rural areas. In The Technological Transformation Of Rural India (eds Bhalla, A. S. and Reddy, A. K. N.), Intermediate Technology Publications, London, 1994.
- 
-

## “Kasish”: School Science Societies

P.C. Vyas

Chief coordinator, Rajiv Gandhi Study Circle & Consultant, Council of Boards of School Education (COBSE). Former Professor of Chemistry University of Rajasthan, Jaipur. Former Chairman, Board of Secondary Education, Rajasthan, Ajmer. Former President, COBSE, New Delhi, INDIA

**Abstract.** The importance of science and technology in everyday life is a common experience of life for one and all. But educators, scientists, technologists, researchers and science communicators all over the world have become aware in last two decades of the importance for Science literacy for all since the World deceleration on Science.. The use of scientific knowledge is part of the right to education and right to scientific information entitles all people for human development and creation of endogenous scientific capacity for peaceful co-existence .It has become a national priority for both developed and developing nations. The developing nations have yet to attain the goals, of education for all (EFA). The path way to SEFA is another major challenge for them. A synergy between the both is of paramount importance for endogenous development of knowledge society with myriads of capabilities to successfully meet the challenges of 21<sup>st</sup> century.

### Science education for all (SEFA)

Science education is important for economic development of the country. Consequently sustainable development depends on scientifically and techno logically literate population to ensure higher technological development and better quality of life to every citizen .Thus a higher quality SEFA is necessary for the fulfillment of basic needs of population. It empowers people to solve specific problems and relate to the aspirations and needs of society through utilization of scientific and technological knowledge and skills. The capacities of the people to utilize these traits very much depend upon the mental attitude or scientific attitude which is acquired by understanding the process

and methods of science. It is an essential requirement of scientific temper.

### The Crusade for Scientific Temper.

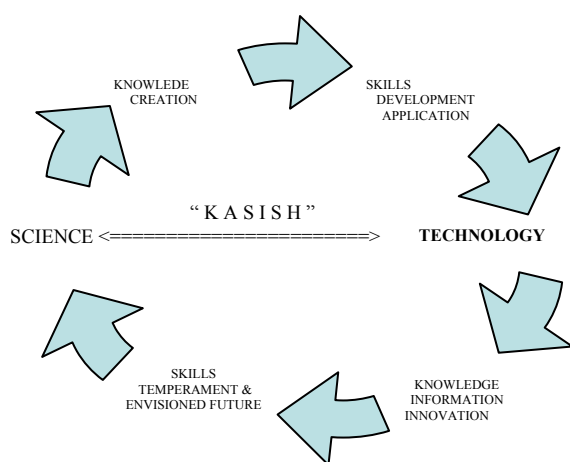
Our first Prime Minister Pt. Jawaharlal Nehru persistently wanted people of India to acquire scientific temper so that they could conduct their thoughts and actions in scientific manner to become better scientists and citizens of tomorrow. In the Presidential address to the Indian Science Congress session held in Delhi in 1947, he pointed out the importance of approach of science to our national problems in terms of India's future. An extract from the speech to quote, “it is a tragedy that when these enormous forces (of science) are available in the world for beneficial purposes and for raising human standards to undreamt of heights, people should still think of war and conflict and should still maintain social and economic structures which promote monopoly and create differences in standards of wealth between various groups and people. I invite all of you who are present here, young men and old in the field of science to think in these larger terms of India's future and become crusaders for rapid bettering of the (condition) of the 400 millions in India. I do believe firmly that only right approach to world problems and to our national problems is the approach of science, that is to say, of the spirit and methods of science”.

If we venture to look at the spectrum of problems of integration, Inclusion and innovation in the contexts of social and national development in present times, the significance of his vision becomes very clear justifying that scientific temper is essential for harmony and peace in society .Because It contributes to human development also, the equal access to SEFA is fundamental right of every child irrespective of race, caste, creed, gender, rural, urban and under privileged in the society. All kinds of imbalances must be corrected to achieve the goal of SEFA through integration, inclusion and innovation. The functioning of EFA must be reviewed in the light of goals of SEFA.

### Technology Temper

Technological temper like scientific temper is a social attribute reflecting the inner urge, individual and collective for innovativeness and

skill temperament and abiding faith in application of science and technology that all problems have solutions. That is why technology is defined as practical and application aspect of science. The former signifies application domain and later denotes the cognitive domain of human endeavor. The knowledge creation and skill development are realizations of scientific temper and adoption of innovations and skill temperament are reflections of technological temper. The synergies (Fig. 1) between S & T can be taken as capacity to convert concepts into technology and vice-versa.



**Fig.1. S&T “KASISH” for transformation of concepts into technology.**

Technological temper is essential for creation of technology friendly environment amongst the masses. In truest sense of the word “KASISH” can be used an Indian acronym appropriate to science and technology temper taken together. The meaning of “KASISH” is deep intense desire or passion for an ultimate fulfillment or objective. It is used in romantic Urdu poetry to express intense love or attraction, commitment and dedication.

### “KASISH” for S&T temper.

Former Prime Minister and Bharat Ratana Shri Rajiv Gandhi had intense love or passion i.e. “KASISH” for S&T temper. He laid the foundation of Information and communication revolution in India. The benefits of ICT revolution have reached to all sections of society and regions of country in shortest possible time. There is no example of such mass movement for technology adoption at that scale earlier. He had a passion for application of S&T to practical

problems of poor people. It was narrated by Chairman RGSC and CM Rajasthan Shri AshokGehlot that once he was traveling with Shri Rajiv Gandhi in early eighties in a car in Srinagar. They came across an old man pulling a cart loaded with heavy building material. The man was soaked with perspiration and was trying to pull the cart up an incline inch by inch taking long and deep breaths at every step. In a spur of moment Shri Rajiv could feel the pain and plight of old man and remarked can’t we do such small things that to use ball bearings and rubber tiered wheels.

The importance of S&T temper for masses was elaborated by him in address to IIT Delhi. While appreciating the contribution of IIT’s to the country’s technical man power he said “Panditji spoke many years ago about developing a scientific temper. This has not yet spread among the masses”. He emphasized the importance of the technological attitude and the technological temper, percolating deep down to the level of our masses. He thought the level of sophistication in our work function will be going up because of the wide spread use of electronic gadgets, microprocessors and computers in consumer and industrial sectors. The visualization turned out correctly when we see our mechanics repairing sophisticated micro processors, computers and hundreds of all types of sophisticated electronic gadgets in our country. With above mentioned preamble, the meaning of “KASISH” can be understood as; where K = Knowledge, A = Attitude, S = Skills, I = Innovation, S = Scientific temper and H= Human development. It is this passion or “KASISH” that is needed among all stake holders to transect S&T temper to masses through SEFA.

### Why School Science Societies?.

It is well established practice that science is better learned by doing and technology is perfected by putting it in to practice. Schools can be a collective and co-operative platform for all stake holders to reap the benefits of SEFA. The learning of science as exploratory and enquiry based enterprise has not taken roots in educational structures and class rooms. There exist wide gaps between the objectives of students, teachers, parents, societies and governments regarding science, technology and

mathematics education (STME) and its expected outcomes. The situation in this regard is nearly similar in developed and developing countries as evident from the world resolutions for STME. Some of the important reforms needed in its nature and structures are as follows.

- There is need to improve, strengthen, diversify and restructure STME both for formal and non-formal education with the objectives for sustainable development.

- The curriculum and pedagogic reforms in structure, content and delivery of STME are necessary in accordance with social and cultural expectations of the people.

- The inquiry based and exploratory method for learning STME is used so that learner himself can construct the knowledge.

- STME should not be seen as an instrument of warfare. It can be used as knowledge for conflict resolution by including subjects such as energy, pollution, environment, health care, medicine and use of resources and application of bio-technology, nanotechnology and nuclear energy for peaceful purposes.

- STME has to be all inclusive to ensure equity of gender, participation of marginalized groups, impact of globalization, public understanding of its influence in daily life, concern for ethics human rights and culture of peace.

- Teacher is the vehicle for desired reforms. The institutionalized training (pre-service and in-service training) of teachers and their professional development must receive a central place in resource planning.

- Integration of Information and communication technology (ICT) in curriculum transaction for effective learning and life long learning.

- Financial and resource inputs are necessary for developing an enabling environment for S&T learning. The society and Government must take responsibility for the same.

- Essentially the spirit of STME and scientific temper in society can contribute to respect for human rights and dignity of labor.

- If you go into the long history of science education reforms and efforts made by scientists at different forums as mentioned following it, it emerges out that science and technology education has yet to reach to masses. It must emerge as inclusive and integrating human

enterprise as SEFA to power innovations to fulfill the expectations of a large mass of humanity. **F School Science Societies (3S) and 3I (initiatives).**

Though Science is international in character but there is not a single model of application of science to solution of problem of different societies. Models based on geographical location, environment, technological thrust and nature of societies can be developed. The important **functions of the 3S and 3I (Integration, Inclusion and Innovation) initiatives** would be to bring perceptible change in quality of STME at school level and build up an environment for SEFA and act as proactive forum to implement its charter mentioned above by using Gandhian technique of educating communities. The core activities of 3S will consist of following objectives.

- (1) Spreading of science literacy with involvement of all stake Holders including students (children) teachers, parents and all sections of society.
- (2) Provide a forum to teachers to engage themselves in science Popularization to become science communicators besides the class room teaching.
- (3) Organize interactions of scientists and technologists with stake Holders to promote excellence, child centered and inquiry based learning of STME at schools and nurturing talents.
- (4) Involve parents, teachers and children in learning science by doing through activities such as projects, exhibitions, fairs, rallies, so as develop schools as centers of lifelong for all in KASISH for S&T temper.
- (5) Promote interdisciplinary approach for coherence of ideas and Understanding of applications of S&T for the society and its implications in a democratic work culture.
- (6) Spreading science education for all in the rural areas and building with traditional knowledge.
- (7) Organize science camps for skilled work force and service providers.
- (8) Sensitization and participation of community for integration of ICT
  - Introduction of computer education in schools
  - Integration of ICT within STME systems for individuals to update their knowledge and acquisition of new skills.

- Committed websites and search Engines for STME.
  - Total computer literacy campaign among teachers
    - Virtual classroom facilities
    - Use of educational satellite facilities and access to all
    - Multimedia learning
    - On-line learning and examination
    - Virtual center for science capacity building
  - (9) Net working of individuals and institutions for exchange of knowledge for the Improvement of the science teaching in schools.
  - (10) Motivation of NGOs and Voluntary organizations and civil society is most important for creation and sharing of information of and for implementing well designed practices in SEFA.
  - (11) The collection of data for all inclusive content of teaching and learning for the equitable reflection of all sections of society.
  - (12) Bringing coordination between public, science communicators, media and civic Society towards the positive impacts of implementation of SEFA.
- Introduction of computer education for Class IX – XII.
  - Organization of International conference on IT education with involvement of teachers.
  - Organization computer literacy and education week (20<sup>th</sup> to 26<sup>th</sup> august every year) and rallies by school for sensitization public towards importance of ICT.
  - Organization of theme based science exhibitions by school children.
  - Personality development camps to inculcate S&T temper for talented and meritorious students (class ix to xii) at school, district and state level.
  - Talent scholarships for students at district and state level for best science projects, models, demonstrations etc in science exhibitions and fairs.
  - Kalpana Chawla computer education and Dr. D.S. Kothari Science scholarships in every district.
  - On-line quiz competitions on scientific knowledge and awareness
  - Merit scholarships for performance in computer education.
  - Teachers training Programmes in every science subject and financial assistance to teachers for project work.
  - Sensitization and motivation of teachers unions, subjects and professional association on reforms of STME.

**Some experiences in implementation of reforms in science education** through (3I) school science based approach (1999-2004) in state of Rajasthan:

- Participatory involvement of teachers in curriculum reforms through decentralized approach through school and district level Curriculum Committees.
- Discussion on Curriculum Reforms in divisional and zonal Conferences.
- Task forces and committee for comparative study of directions of curriculum reforms.
- State level committees to finalize structures of curriculum reforms.
- Subject Committee consisting of University Professors, Science Researchers, and School teachers and faculty from professional technical institutes for framing of syllabi of science subjects.
- Pre review of these syllabi by group of scientists.
- Involvement of all stake holders in writing of text books through workshop method following above mentioned process and representation.

### References.

- Dr. D.S.Kothari, education commission (1964-1966).
- UN millennium Development goals (MDG) (2000).[www.un.org](http://www.un.org), [www.undp.org/basics](http://www.undp.org/basics) .
- Dr. P.C. Vyas, Rajasthan Board of Education Journal (BSER) (2001 & 2002), World declaration on science and the use of scientific knowledge. science for twenty first
- Century UNSCO Budapest, Hungary (1999), [www.un.org](http://www.un.org).
- World Education Forum, Dakar ,Senagal, April (2000) ,[unesco.org/education/efa/wef\\_2000](http://unesco.org/education/efa/wef_2000)
- Project 2000 + The global agenda for reforming S& TE, [www.unesco.org/education/2000](http://www.unesco.org/education/2000)
- Dr.P. C. Vyas, Raj Board Panorama, The Board of Secondary Education Rajasthan, (2003).

- STME for human development (CASTME-UNESCO-HBCSE) portal .unesco.org/ 2001.
  - Science Education seminar, INSA-May (2002), Science education workshop INSA Oct. (2002). www.insaindia.
  - Dr. APJ Abdul Kalam, India Empowered Conclave, Indian Express December 21 (2006)
  - Dr. P. C. Vyas, Curriculum vs Designs. Towards Universalizing Secondary education,
  - COBSE Conference Report Goa, 17-19 January (2006).
  - Dr. P. C. Vyas Science of Assessment for Quality Education, COBSE Conference Report Goa, (17-19 January (2006). Quality science education reforms
  - Dr.P.C.Vyas. COBSE Conference Reshikesh, Hardwar Sept. (2008) Dr.P.C.Vyas, Re-designing Chemistry education (CE) frame work for school education, COBSE conference Pune, May (2008)
  - Bullock, D. Journal of Technology and teacher education, 12 (2), 211-237 (2004)
  - Ediger, Marlow and D. Bhaskara Rao School science education, New Delhi, Discovery Publishing House (2007).
- 
- 

## Innovations in Teaching Physics of Sound

A. Garg, R. Sharma, V. Dhingra,  
A. Kumar and Z. Khan  
Department of Electronics, Acharya  
Narendra Dev College, University of Delhi,  
Govindpuri, Kalkaji,  
New Delhi-110 019, INDIA  
amit\_andc@yahoo.co.in

**Abstract** In this paper, we report the development of a teaching aid based on LabVIEW for understanding various aspects of sound like loudness, pitch, timbre and audibility range of human beings. In traditional lab environment, these concepts of sound study are difficult to demonstrate. The developed system provides an introduction and insight to the physics of sound using Fourier transform implementations. The various properties of the acquired sound signal from several sources including a function generator, recorded sound file from a musical instrument(s), human voice etc. can easily be varied in the developed application and the resultant effect can be noted simultaneously in form of a sound output on a speaker and its Fourier transform display. This helps the student understand the effect and importance of these parameters of sound individually which remain ambiguous otherwise.

**Keywords:** audibility range, loudness, pitch, timber.

### 1. Introduction

Sound is defined as the vibrations transmitted through elastic solid, liquid or gas, with frequencies in the approximate range 20 Hz to 20 KHz, capable of being detected by humans. There are three important aspects of sound waves that determine what one hears: Loudness, Pitch and Timbre. The amplitude of the sound wave determines how loud a sound is. Musical tones consist of a fundamental frequency which is mostly responsible for the pitch perceived by the ear and a number of higher harmonics, frequencies that are integer multiples of the fundamental. The higher harmonics that are present and their amplitudes comprise the Fourier spectrum of the tone that is responsible

for the quality or musical timbre perceived by the listener. Quality or timbre is why different musical instruments sound different even when being played with the same pitch and similar loudness.

Students up to the high school level are taught the basics and various properties of the sound waves. However, the different aspects like audibility range of humans, pitch, loudness and quality of sound wave remain difficult to visualize and understood by the students due to lack of proper laboratory tools/experiments that could reflect the effect of these parameters individually. The developed application can be used as a teaching aid to ease out the understanding of these concepts.

## 2. Theory

A violin and a flute may both be played at the same time in an orchestra. Both sounds travel through the same medium, that is, air and arrive at our ear at the same time. Both sounds travel at the same speed irrespective of the source. But the sounds we receive are different. This is due to the different characteristics associated with the sound. Pitch is one of the characteristics. How the brain interprets the frequency of an emitted sound is called the pitch. The faster the vibration of the source, the higher is the frequency and the higher is the pitch, as shown in Fig. 1(a) and (b). Thus, a high pitch sound corresponds to more number of compressions and rarefactions passing a fixed point per unit time. Objects of different sizes and conditions vibrate at different frequencies to produce sounds of different pitch.

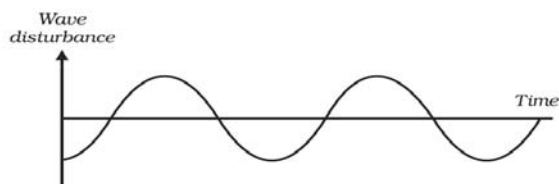


Figure: 1 Sound signal (a) Low pitch

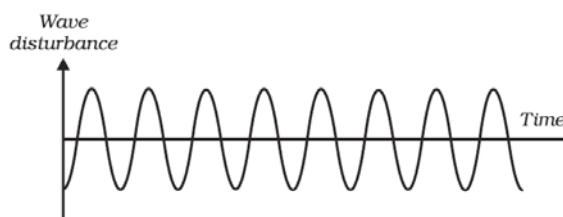


Figure: 1 Sound signal (b) High pitch

The magnitude of the maximum disturbance in the medium on either side of the mean value is called the amplitude of the wave. The loudness or softness of a sound is determined basically by its amplitude. The amplitude of the sound wave depends upon the force with which an object is made to vibrate. If we strike a table lightly, we hear a soft sound because we produce a sound wave of less energy (amplitude). If we hit the table hard we hear a loud sound. Fig. 2(a) and (b) shows the wave shapes of a loud and a soft sound of the same frequency.

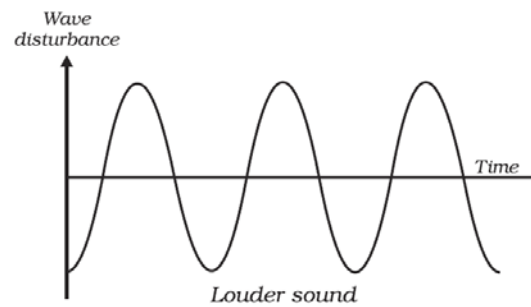
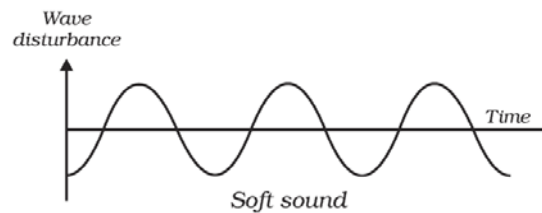


Figure: 2 Sound signal (a) Low amplitude (b) High amplitude

The quality or timber of sound is that characteristic which enables us to distinguish one sound from another having the same pitch and loudness. The sound which is more pleasant is said to be of a rich quality. A sound of single frequency is called a tone. The sound which is produced due to a mixture of several frequencies is called a note and is pleasant to listen to. Noise is unpleasant to the ear while music is pleasant to hear and is of rich quality [1].

Most sounds, including musical notes, are not pure tones. They are a mixture of different frequencies (tones). A tuning fork, when struck, produces a pure tone of a specific frequency. This pure tone is produced by regular vibrations of the source. On the other hand, scraping your fingernails across a blackboard only creates noise, because the vibrations are irregular. Each individual pipe of a pipe organ is similar to a tuning fork, and each pipe produces a tone of a specific frequency. But sounding two or more



pipes at the same time produces a complex waveform. Fig. 3 illustrates the combining of two pure tones to make a COMPLEX WAVE.

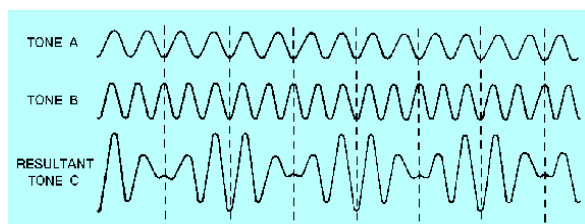


Figure: 3 - Combination of tones

The QUALITY of a sound depends on the complexity of its sound waves, such as the waves shown in tone C of Fig. 3. Almost all sounds (musical and vocal included) have complicated (complex) waveforms. Tone A is a simple wave of a specific frequency that can be produced by a tuning fork, piano, organ, or other musical instrument. Tone B is also a simple wave but at a different frequency. When the two tones are sounded together, the complex waveform in tone C is produced. Note that tone C has the same frequency as tone A with an increase in amplitude. The human ear could easily distinguish between tone A and tone C because of the quality. Therefore, we can say that quality distinguishes tones of like pitch and loudness when sounded on different types of musical instruments. It also distinguishes the voices of different persons [2].

### 3. Experimental setup

The experimental set up for the developed system utilises the microphone audio input and the audio output through speaker attached to the PC as illustrated in Fig. 4. The sound signal under study is converted to its electrical equivalent through the microphone which is saved as a sound file in wave format. This file or any other file already saved in the same format can be sent to the LabVIEW based developed application program for analysis.

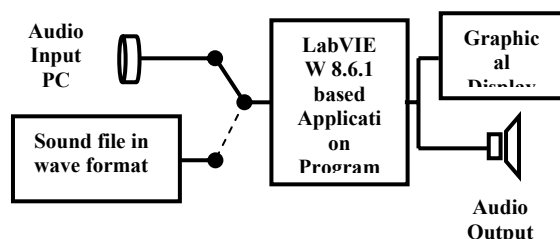


Figure 4 – Experimental set up for the developed system for sound study

The developed software consists of two sections: Audible Range Verification and Sound Analysis. The section for audible range verification generates a continuous beep sound using the built in speaker in the computer. The frequency of the generated beep can be controlled using a frequency dial control on the front panel which ranges from 10Hz to 100 kHz. The audible range for a person can be displayed based on the frequency values where a user starts and stops to hear a beep when the frequency dial is varied. The output frequency is displayed on a digital meter.

The sound analysis section moves into a deeper study of sound waves by playing and plotting different sound files saved in wav format. The sound wave is displayed in time and frequency (FFT) domain on two separate waveform graphs. The variation in pitch (fundamental frequency) of the sound wave over time is further displayed on a third waveform graph. This section also provides the user with an ability to vary the different components of the sound wave for detailed study. For loudness study, the user can vary the amplitude of the sound wave using the loudness control. Variation in amplitude results in change in the loudness of the sound wave which can be played simultaneously on the audio speaker output of PC. For the timbre study, number of frequency components of the sound wave can be varied using a low pass filter. By varying its cut off frequency, the number of components present and their effects can be online studied for better understanding of the timbre components.

### 4. Results and discussion

The screenshots of the developed software in two modes are illustrated in Fig. 5(a) and 5(b).

The underlying graphical code for the developed system is shown in Fig.6.

The Audibility range section has been tested. Tone is audible in the range of 19 to 14500 Hz. Outside this range, sound is audible as clicks only which signify activation of the speaker with no sound output. The difference in the audible range in comparison to that of human beings can be due to non response of the speakers outside this range and may require some specialized speakers.

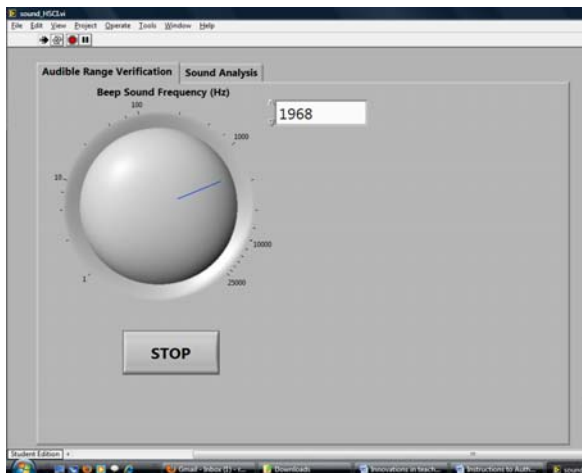


Figure 5(a) – Screenshot of developed software for audible range verification

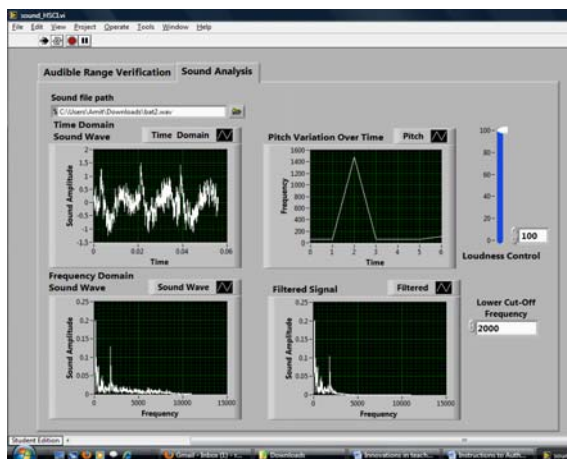


Figure 5(b) – Screenshot of developed software for sound analysis

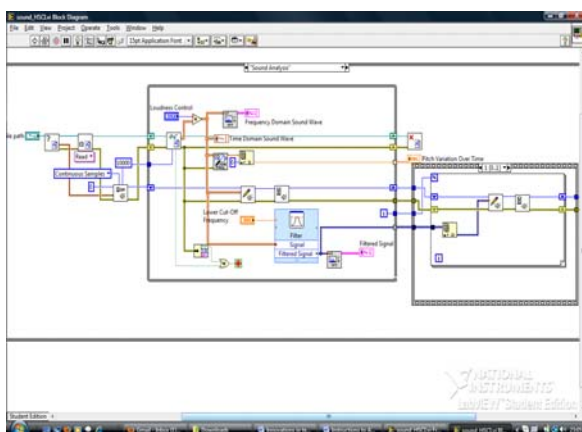


Figure 6 – Graphical code for the developed software in LabVIEW 8.6.1

Sound signals from various sources were analysed to study the changes in the different components of the signal. The sources included sound signals produced by bats, musical

instruments, baby and adult voices, tuning fork etc.

In the sound analysis section, one can browse and select any wav format file from the PC. First display shows the amplitude variation with respect to time. Second display shows the FFT components of the file played. The fundamental frequency has been displayed in the third graph indicating the pitch value. No changes have been observed in the pitch by varying the loudness of the sound. The frequency components filtered and their effect has been shown in the fourth display and changes in the quality of the sound heard can be easily felt.

Questions that can be integrated by the teacher with the demonstration to enhance better understanding can be as follows:

1. Explain the terms audibility range, loudness, pitch and timbre
2. Run the section 1 of the application and show the audibility range of human beings. The audibility range can be compared with other animals like dog, bat etc. Uses of the sound outside the audible range: Ultrasound, SONAR and Echolocation can be discussed.
3. Run the section 2 and vary the sound in terms of loud and soft sound, high and low pitch sound in order to make the students aware of the concept of loudness and pitch. Effect of varying the loudness and its consequence on the fundamental frequency can be questioned.
4. For demonstrating the Timbre effect, various frequency components can be selected and the expected changes in the sound output can be questioned.

Function of equalizers/music synthesizers can be introduced.

The developed software is a handy tool for teaching the concepts of sound with ease. The minimal hardware requirements and the easy availability of a PC system makes the developed tool cost effective, hence it becomes easier to introduce it any level of education system.

Also, teachers can further refer [3-5] for demonstration and reading to improve their understanding of the three acoustic sensations.

## 5. Conclusion

The developed system presents a simplistic approach to the idea of associating loudness with wave amplitude, pitch with frequency and timbre with the overlapping of higher harmonics. However, these concepts are quite complex and to an extent interdependent and needs to be related to other factors like our psychoacoustic system. Using LabVIEW, many software applications can be developed that makes it easy to experiment with loudness, analysis-synthesis of sound which bring out the subjective nature of the sensations of loudness, pitch and timbre, providing evidence of the great number of factors on which they depend.

## 6. Acknowledgement

Authors, Amit Garg and Vishal Dhingra, duly acknowledge University Grants Commission, New Delhi, India for providing the financial assistance under the major research proposal scheme for the work reported in this paper against sanction no. 34-62/2008(SR) for the project entitled “Investigating science hands-on to promote innovation and research at the undergraduate level”.

## 7. References

- [1] NCERT, Class IX Science book, Chapter 12, page-165,166
  - [2] <http://www.tpub.com/neets/book10/39e.htm>, Electrical engineering Training Series, Integrated Publishing [accessed on 9<sup>th</sup> October 2009]
  - [3] <http://science.education.nih.gov/supplements/nih3/hearing/activities/lesson1.htm>
  - [4] J Mariano Merino Physics Education 1998; 33: 101-104
  - [5] J Mariano Merino Physics Education 1998; 33: 105-109
- 
- 

## Prevention of Teenage Obesity

J.M. Pereira da Silva

Colégio Internato dos Carvalhos, Rua do  
Padrão, 83 – 4415-284 Pedroso,  
Vila Nova de Gaia, PORTUGAL  
zemanel@cic.pt

**Abstract.** This work started from an inquiry which aimed at knowing the food habits of the teenagers attending Colégio Internato dos Carvalhos – CIC. These inquiries were structured so as to obtain the information by gender and divided into two different age sectors: 10, 11 and 12, and 13, 14 and 15-year-olds. The questions asked highlighted the more problematic aspects of the youngsters’ feeding habits.

To enable a more adjusted confrontation between the obtained results and the ones that come from previous researches, we moved on to a field work consisting of getting some biometric data of the studied population. This information was given voluntarily and anonymously.

Issued publications were a challenge which ends up by materializing in this project of study and investigation/action whose first goal is to sensitize the adolescent school population (from 10 to 15) to adopt healthy food habits accordingly to our traditional Mediterranean cuisine.

The results provided a way to alert the young population to the risks of obesity and the consequent diseases.

**Keywords:** education and health, food habits, health promotion, obesity prevention.

## 1. Introduction

One of the greatest social concerns nowadays is the changes that teenagers’ food habits are going through. This issue is being studied in almost every European country and, among us, it is also something to worry about.

Studies point out that about 1/3 of the adolescent population in Portugal is obese. If, for the general population, obesity is a public health concern, when it comes to teenagers, it becomes a lot more serious. It’s a matter of making sure that future generations don’t get compromised with heart disease and diabetes, among others.

However, we faced some setbacks when gathering this biometric data. As this information gathering was volunteer and at random, some of the youngsters who might, apparently, be the more worrying cases did not participate<sup>[2]</sup>.

## 2. Methodology

The methodology used in this project was based on a group of tasks which aimed at gathering and treating the necessary data for a new stage. The different stages of the project were:

- Bibliographic web searching for existing essays in this area – medical sciences, more precisely nutrition sciences;
- Preparing an inquiry that was filled in by the target population– teenage students<sup>[3]</sup> from 10 to 15;
- Treating the inquiry results on the youngsters’ food habits and analyzing those results;
- Obtaining some biometric data of the target population – weight and height;
- Treating the teenagers’ biometric data and confronting the results against the patterns adopted by specialists;
- Concluding the work done, which was presented as a proposition for future action that allows teenagers to adopt new and healthier food habits based on the Mediterranean cuisine;
- Show the study and its conclusions to the Board of Directors and Parents Association.

## 3. Field Work

This inquiry was aimed at students aged, at the time, between 10 and 15 that attend Colégio Internato dos Carvalhos (CIC) in 2008/09, in a total of 655 individuals.

### 3.1 Inquiry on Food Habits

To allow a more accurate reading of the target population we divided them in two subgroups:

- 1<sup>st</sup> subgroup – “Submissive” adolescence, those aged 10, 11 and 12, who follow family advice and obey their rules;
- 2<sup>nd</sup> subgroup – “Rebel” adolescence, those aged 13, 14 and 15, who need to affirm themselves in front of their peers.

The 1<sup>st</sup> subgroup presents distinctive features which are common to most youngsters at this age. When there is parental knowledge and worry, boys and girls are forced to take their breakfast at home and the food is supervised and selected by adults. It is important to mention that, generally, these teenagers don’t get the usual daily or weekly allowances, so they can’t afford to buy food; instead, they take it from home<sup>[1]</sup>, eating it during breaks that coincide with the regular mid-day meals. These snacks are often prepared by parents and they consist of fruit, bread or dairy products. Actually, at this age, they are still obedient to their parents’ advice or impositions and they go on doing the same for the rest of the meals. For example, they must eat soup (in some school canteens they also have to), dishes accompanied by salad and no fried items, and when it comes to dessert, fruit or yoghurts are preferable.

The 2<sup>nd</sup> group presents its own characteristics, common to most adolescents at this age. The fact that they are in a growing phase, when it is important to acquire responsibility and maturity, is reflected on their own choices as to what their diet is concerned. Most of them receive a daily or weekly amount of money which gives them some freedom to choose the kind of things they want to consume: fizzy drinks, sweets, chocolates..., which are bought near or at school, even during the lunch break. Rebellious attitudes are associated to this subgroup and that is reflected in their eating habits: having no soup, vegetables or other healthy items constitute contradictory attitudes that work based on the influence of peers. This adolescent behaviour is connected to their need of personal affirmation facing parents, teachers, colleagues and family.

Since it is a mixed school population, with quite a representative sample, we realized it was quite important to gather data by gender.

#### 3.1.1 The Inquiry Model

The inquiry model [Fig.1], was prepared so as to know the level of intensity or interest in the important subjects concerning the daily food habits<sup>[4]</sup>, such as:

- Breakfast and snacks;
- Drinking water and milk
- Eating soup, fish and bread;
- Eating fruit, salads and vegetables;
- Eating sweets and fries.



Colégio Internato dos Carvalhos  
 Curso Científico-Tecnológico de Biotecnologia

**COMPORAMENTOS ALIMENTARES DOS JOVENS DO CIC**  
**INQUÉRITO**

Questão	1	2	3	4	5
1. Tomas o pequeno-almoço diariamente?					
2. Quando tens sede bebes água?					
3. Comes no intervalo das refeições principais?					
4. Com que regularidade comes sopa?					
5. Comes fritos?					
6. Comes doces à sobremesa?					
7. Consomes leite ou seus derivados?					
8. Com que frequência comes frutas?					
9. Costumas comer saladas?					
10. Comes pão?					
11. Com que regularidade comes vegetais?					
12. O peixe faz parte das tuas refeições diárias?					

Gradação das respostas  
 1 – Nunca  
 2 – Raramente  
 3 – Às vezes  
 4 – Frequentemente  
 5 – Sempre

Idade: ..... Sexo: M  F

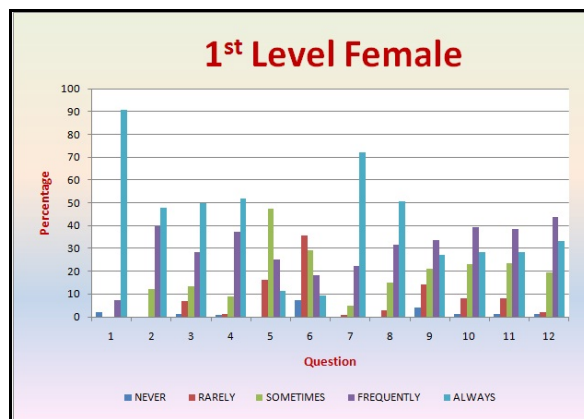
12.º BT2 – Tecnologia de Processos Alimentares ..... 2008/2009

Figure 1. Inquiry model

These inquiries were presented as a game with eventual contradictions which aimed at making sure that/if they were refusing some practices just because they knew it wasn't the correct thing to do.

### 3.1.2 Inquiry Treatment

The questions were treated individually, by age and gender, according to the graphics.

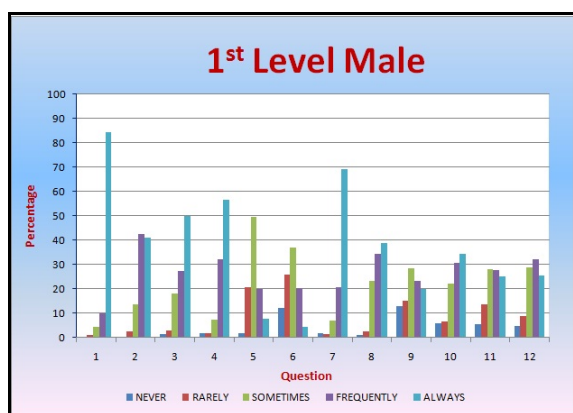


Graphic 2. 1<sup>st</sup> female subgroup

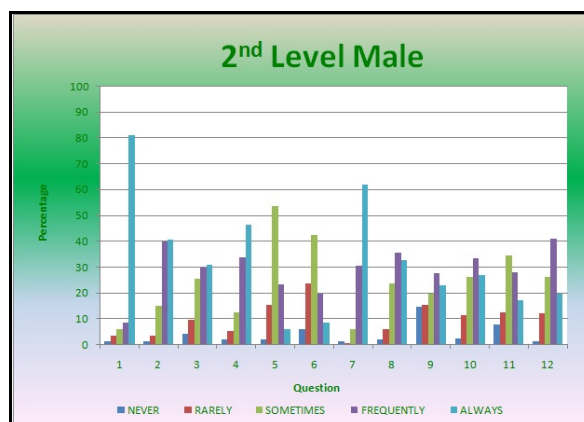
The graphics suggest that all adolescents of the 1<sup>st</sup> male subgroup have their breakfast and when they are thirsty, they drink water. More than a half eats soup but only half of them have snacks between meals.

We realized that there are different percentages for the fried items but 20% of them usually consume this kind of food. As to what dessert is concerned, just a small percentage, 12%, never eats sweets. More than a half consumes milk and dairy products, which are a source of calcium and that is a positive result. Fruit is used by all of them. When it comes to salads and vegetables, they are not always present in their meals. And while bread is almost always present, fish is chosen by only 25% of the teenagers. Comparing girls to boys of the 1<sup>st</sup> subgroup, there is no significant difference in their habits.

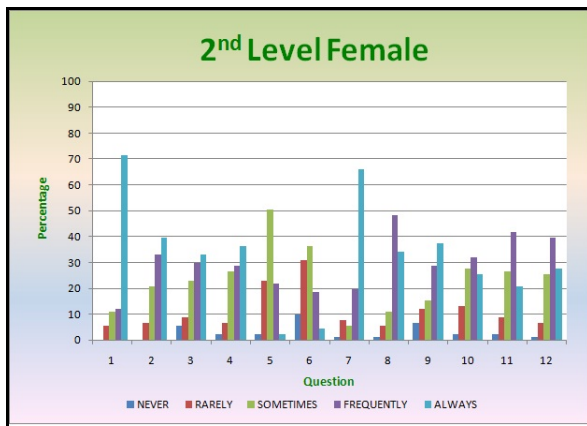
Using the same inquiry, the results for the 2<sup>nd</sup> subgroup are the ones presented in the graphics that follow:



Graphic 1. 1<sup>st</sup> male subgroup



Graphic 3. 2<sup>nd</sup> male subgroup



Graphic 4. 2<sup>nd</sup> female subgroup

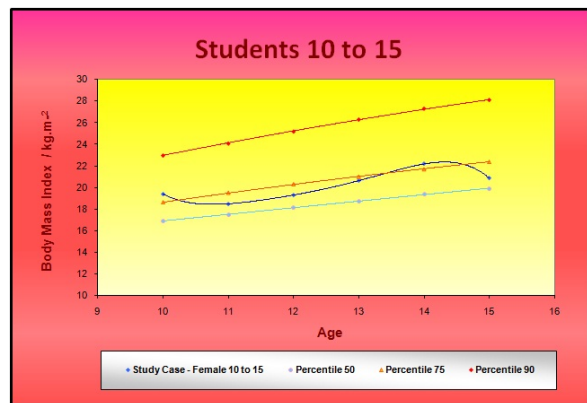
These graphics show that almost every teenager of the 2nd male subgroup have breakfast. When they are thirsty they usually drink water, but about 15% doesn't. The mid-day snacks are part of the feeding habits of only 30%. And while 50% of the students from this group eat soup, we noticed that fried food is present in their diets. And although the percentages vary, more than 50% of them eat that kind of food and don't avoid sweets for dessert. More than a half of these students always have milk and/or eat dairies. Salads and vegetables aren't always present in their dishes. Bread is consumed in a reasonable amount and fish is eaten by about 40% of the teenagers in the group. The girls of this subgroup have the same kind of feeding habits as boys, which means there are no significant differences.

### 3.2 Biometric Data

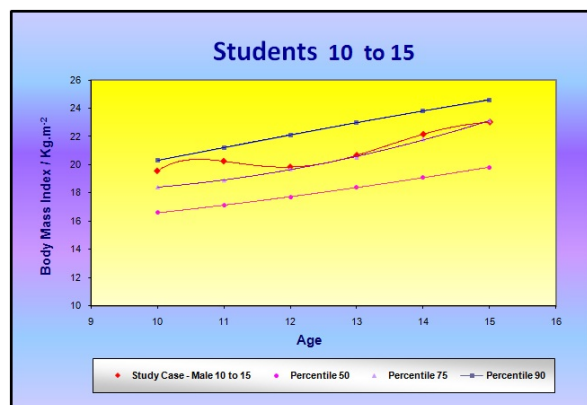
The gathering of biometric data was based on two important assumptions if the following conditions were respected:

- The biometric student data was the students' free option;
- The only items to be registered were sex and age.

We must emphasize that we were careful to avoid repeating readings of the same individual. The biometric data was focused on weight and height. It seems not to be enough but it was quite useful for the research. This data was grouped by gender and age resulting in the reading of different graphics.



Graphic 5. Female adolescents



Graphic 6. Male adolescents

### 3.2.1 Biometric Data Analysis

According to the graphics, we may conclude that there are no obesity cases among our students that reach or exceed the 90 percentile, established by the international organisms<sup>[5]</sup>, as the limit pattern value, from which an individual can be considered obese.

From the analysis by gender, we can see that teenage females go after the 75 percentile. If this percentile is not attained at 11, 12, 13, and 15, it shows a relatively satisfactory situation for the young girls that attend CIC.

As to the young males, of 10 or 11, we can see that the percentile is above 75, which means that they already have a tendency for obesity at such a young age. The older students (from 12 to 15), close to percentile 75, go over their BMI and they need a careful control.

As there are no worrying cases (those above percentile 90), we assume that the students at CIC should be monitored for the next few school years, aiming at preventing the so called "social disease" that is named obesity.

## 8. Acknowledgements

I thank all students that dealt with the subject Industrial Technology of Food Processes that have attended the 12<sup>th</sup> form of the Secondary Course of Biotechnology – BT2, in Colégio Internato dos Carvalhos, who were deeply involved in this project. We also thank Edite Pereira da Silva, our English Teacher.

## 9. References

- [1] Gay Gray, Ian Yong and Vivian Barnekow. **Developing a health-promotion School**. P. 28.  
<http://www.euro.who.int/ENHPS>
  - [2] Bjarne Bruun Jensen, Venka Simovska, Niels Larsen, Leif Glud Holm. **The Young Minds approach and its relevance for the Children's**. Environment and Health Action Plan for Europe (CEHAPE). P.9. Young people want to be part of the answer.
  - [3] Vivian Barnekow, Goof Buijs, Stephen Clift, Bjarne Bruun Jensen, Peter Paulus, David Rivett & Ian Young. **Health-promoting schools: a resource for developing indicators**. Student's participation. P. 27.  
<http://www.euro.who.int/ENHPS>
  - [4] Danielle Piette, Chris Roberts, Marianne Prévost, Chris Tudor-Smith and Jaume Torti Bardolet. **School health promotion criteria**. P. 20. Tracking down ENHPS successes for sustainable development and dissemination. The EVA2 project1 - Final report
  - [5] **CDC Growth Charts: United States**
  - [6] Developed by the National Center Health statistic in collaboration with the national center for chronic disease prevention and health promotion (May 30, 2000)
- 
- 

## Communicating Science to the Tribal Communities of Assam through Hands-on Training

A. Dutta<sup>1</sup> and A. Ray<sup>2</sup>

<sup>1</sup>School of Professional Studies, K. K. Handique State Open University, Dispur, Guwahati-6, Assam, INDIA

<sup>2</sup>Dept. of Communication and Journalism, Gauhati University-14, Guwahati, INDIA  
[ankurandutta@yahoo.co.in](mailto:ankurandutta@yahoo.co.in),  
[anamikadady@rediffmail.com](mailto:anamikadady@rediffmail.com)

## Prologue

The tribal people are very close to the nature. They are influenced more by socio-cultural and environmental dimensions in their way of lives. They have their own code of conduct, practices and taboo. They are generally more tradition bound and persist in their age-old faith and cultural values vis-à-vis the non tribal community. The tribal continue to be among the weakest and most exploited section of society. Each tribal community is a distinctive unit with its own socio-cultural background. The tribes differ from each other ethnically, linguistically and socio-culturally, as a result the problems differ from tribe to tribe and region to region. So, tribal development became one of the most burning issues of the hours. And the science is the key factor of development. Not only that, knowledge on science of common mass is another crucial factor for society development in democratic way. This is particularly in the third world countries like India inhabited by millions of tribal. Without communicating science among the tribal communities, we can not even imagine the tribal development. Science cannot be isolated from the social and cultural context of the tribal community.

But still most of the tribal communities are following the image of forefather footstep. For example, tribal belief relates to sickness, death and good health to the good will of the deities worshipped by the concerned tribes. Though tribal health care system is based on herbal medicines and the Ayurvedic medicines, but most of times they depend on the magico-religious practices. Hunger, low levels of productivity, low wages, superstition and

indebtedness are hindrances in the developmental process of the tribal communities.

Due to the lack of science information or the improper methods of the dissemination of the science among the tribal people, they suffer acute health and nutrition problems. Poor concept on the clean drinking water and sanitation, lack of proper accommodation, poor infrastructure and ineffective coverage of national health and nutritional services are some of the causes for underdevelopment.

This research work aims at the development and the innovation on the proper ways to communicate science to the tribal communities of the state. Folk performances containing science materials are the prime tool for science communication among the tribal communities. The folklore phenomenon in the region represents as a tool of communication by employing verbal, non-verbal, musical and visual folk art forms, transmitted to a society or group of societies from one generation to another. These are indigenous modes and have served the society as tools of communication for ages. Therefore, among the tribal communities in Assam, folk media offer an important apparatus in the process of inspiring rural masses towards accepting social changes, which also establish a constructive means for the upliftment of the tribal people and can build a scientific temperament among them.

This research work also describes other approaches, which can be useful for communicating science among the tribal communities. For instance, use of games with science kits, Public speaking in local dialects, Community media in local dialects, Exhibition-film show, Mobile medical unit, Science material development through translation and interpretation into local dialects etc. to help in cutting across traditional resistance to new ideas.

### **Introducing the land and its people**

Assam, famous world over for its tea, is a land of jaded mountains, singing waterfalls, merry people and ever-smiling young girls. In the past, Ahom kings infused fresh and varied colours into its art and culture. While in the modern times, Shrimanta Shankardev - Madhavdev embellished and enriched it with their enchanting poetry and performing arts and Jyoti Prasad, Bishnu Rabha adorned it with

artistic of different sorts. Besides the much revered Kamakhya Devi of Guwahati has been a source of attraction to devotees from all over the world [1].

The state appears like a quiet bird perched on the crest of a mountain range with Patkai Mountain range forming the bird's break. This Northeastern state of India shares its international borders with China, Bhutan and Bangladesh [2].

Assam, located in the tropical latitudes (24.3 N and 28 N) and eastern longitudes (89.5 E and 96.1 E), is the most populous state in North-eastern India. Assam is surrounded by seven Indian states and two foreign countries. There are only a few Indian states which have such a strategic location. The state has an area of 78,438 sq. km. representing 2.39% of the Indian landmass [3].

The population of Assam consists of an intermixture of Mongolian, Indo-Burmese, Indo-Iranian and Aryan origin. The tribes of Mongolian origin occupy the hilly areas. According to the 1991 census, the population of Assam is 22 million. The Hindu represents two-third of the population and the native Tibeto-Burman tribal groups make up another 16% of the total population. The Native Assamese, Mymensingia settlers (from Bangladesh) and tea garden labourers are also included in this coverage. The state has the presence of largest number of tribes and each tribe has their own language.

The total land area of Assam is 78,438 sq.km which is 2.4% of India's total land area. However, during the period 1981-91, rate of growth of population in Assam was higher than the rate at the all India level. Against the rate of growth of 23.58% in Assam, the all India rate was 23.50% during the decade 1991-2001, the rate of growth of population is 19.85% against the all India rate of 21.34%. [4]

In many ways the foremost of the seven units comprising the North-East, Assam is also more or less centrally located in the region. Assam is the anglicized name for the State that lies between 89.5<sup>0</sup> to 96.1<sup>0</sup> East longitudes and 24.3<sup>0</sup> to 28.0<sup>0</sup> North latitudes. Spread over an area of 78,438 square kilometres, Assam is the second largest State in the northeastern region. It represents 2.39 per cent of the Indian landmass It is bounded by Bhutan and Arunachal Pradesh on the north, Nagaland and Manipur on the east,



Mizoram, Meghalaya and Tripura on the south and south-west, and Bangladesh and West Bengal on the west. The total area of the state is 78,523 square kilometres. The long and narrow Bramaputra valley, also called the Assam Valley, stretches across the state from east to west while the small Barak Valley forms its southern adjunct, the two hills districts - North Cachar and Karbi Anglong - lying in between. According to the Census Report of 2001, Assam has a total population of 26,638,407. It constitutes 2.59 percent of the total population of India and 68.24 per cent of the entire North East. Ranked 14th in terms of total population in India, the State has a density of 340 persons per square kilometre. The literacy rate of Assam is 64.28 and it holds the 24th position in this regard among the Indian States. Assam ranks 26th in human resource development index and 21st in poverty index in India according to the Human Development Report 2001 [5].

Area Profile of Assam <sup>6</sup>			
N° of Households	4,914,823	Average Household Size (per Household)	5.0
Population-Total	26,655,528	Proportion of Urban Population (%)	12.9
Population-Rural	23216288	Sex Ratio	935
Population-Urban	3439240	Sex Ratio(0-6 Year)	965
Population (0-6Years)	4,498,075	Sex Ratio (SC)	935
SC Population	1,825,949	Sex Ratio (ST)	972
ST Population	3,308,570	Proportion of SC (%)	7.0
Literates	14,015,354	Proportion of ST (%)	12.0
Illiterates	12,640,174	Literacy Rate (%)	63.0
Total Workers	9,538,591	Work Participation Rate (%)	36.0
Main Worker	7,114,097	% of Main Workers	27.0
Marginal Worker	2,424,494	% of Marginal Worker	9.0
Non Worker	17,116,937	% of non Workers	64.0
CL (Main+Marginal)	3,730,773	Proportion of CL (%)	39.0
AL (Main+Marginal)	1,263,532	Proportion of AL (%)	13.0
HHI (Main+Marginal)	344,912	Proportion of HHI (%)	4.0
OW (Main+Marginal)	4,199,374	Proportion of OW (%)	44.0

## Tribes and Tribal Status:

India is the home to large number of indigenous people, who are still untouched by the lifestyle of the modern world. With more than 84.4 million, India has the largest population of the tribal people in the world. These tribal people are also known as the adivasi (Adi means old Vasi means those who stay), who are still dependent on hunting, agriculture and fishing.[7]

The word 'Tribe' denotes a group of people living in primitive conditions. It is a social group with territorial affiliation, endogamous with no specialization of functions. They have a headman or a chief who controls the activities of that group. Tribals have several sub-groups all of them together known as 'Tribal Society'. They were living in forests since early times and even now some of the groups follow the same trends and live in forests.

Tribal constitute around 8.08% of the total Indian population. There are around 636 schedule tribe categories in India. They constitute the matrix of India's poverty. Though the tribal are the sons of the same soil and the citizens of the same country, they born and grow as the children of the nature. From the historical point of view, they have been subjected to the worst type of social exploitation. They are practically deprived of many civic facilities and isolated from modern and civilized way of living. [8]

Tribal Population in India <sup>9</sup>	Persons
Total	84,326,240
Rural	77,338,597
Urban	6,987,643

The tribal are situated all over India. Some of the major tribal groups in India include Gonds, Santhals, Khasis, Angamis, Bhils, Bhutias and Great Andamanese. All these tribal people have their own culture, tradition, own folklore, folk songs, dances, own language and lifestyle. With culture they also have their etc. Almost all tribal communities possess rich mythologies, folk tales, stories which illustrate their affinity and relationship with tradition and traditional characters. With traditions they have their own general beliefs. Even though they have a rich culture they are socio-economically disadvantaged and marginalized. Development

planning in India has attempted to foster their empowerment by focusing on food security, health, education, employment and income generation.

Fifty years of such planning, however, has failed to narrow the gap between the tribal and the rest of the population, and has instead actually reinforced the unequal exchange between the two. The scholars examine all the most important issues affecting India's tribal population, including the search for political autonomy, the struggle against land alienation, rights to resource and decision-making, the decline in traditional occupations, environment, ecology and sustainability, displacement caused by large infrastructure projects, the impact of development schemes, globalization and the shift from isolation to integration etc.

Though after independence a new policy of tribal development and integration was initiated and the Constitution of India has made definite provisions for the welfare and uplift of the tribal people throughout the country, the greatest challenge that the Government of India has been facing since independence is the proper provision of social justice to the scheduled tribe people, by ameliorating their socio-economic conditions. Tribal in India, geographically and culturally, are at widely different stages of social as well as economic development and their problems differ from area to area within their own groups. The tribesman lives not only for himself alone, but also he is an integral part of the community to which he belongs.

North Eastern part of India is having many indigenous tribes that even today retain their ancient customs and traditions and live lives that is directly associated with their natural surroundings. Right from the customs and traditions, lifestyle, food habits or the way of earning bread and butter; all the components comprising the schedule of the tribal people hold certain importance in their lives. Each state is made up of a number of tribes, each with their own distinctive culture, language, hand-woven dress and handicrafts etc. Some of the prominent tribal communities include Nagas (who consist of many individual tribes), Khasis, Jaintias, Mizos, Boros, Cacharis and Karbis. The Karbis are one of the important tribal groups of the north east of India, who are known for their traditional songs and dances, their colourful

handmade clothing and intricately woven bamboo handicrafts.

The basic economic activities of these tribal may be considered as food gathering, pastoral, cultivation, handicrafts, trade and Commerce, labour. Like some other tribes, Karbis are an ethnic tribal group scattered in North East India with a concentration in Assam. Once they were believed to have lived on the banks of the rivers the Kalang and the Kopili and the entire Kajiranga area, the famous National Park situated in Assam. In fact the word Kaziranga as it is known today has been derived from a Karbi word, 'Kajir-a-rong', which means "Kajir's Village" or "Kajiror-gaon". Kajir is a female name among the Karbis.

The need for tribal development in India hardly calls for any justification. Their primitive way of life, economic and social backwardness, low level of literacy, hackneyed system of production, absence of value system, sparse physical infrastructure in backward tribal areas and demographic quality of tribal areas coupled together make it imperative for a systematic process of development of tribal and tribal areas.

One of the long-term needs for tribal development is improvement in their quality of life. Certain basic services like drinking water, health, housing, nutrition, rural roads etc. need to be provided to them. The problem of drinking water in tribal areas is acute. Further, some villages suffer from contaminated water supply. Sanitation and hygiene are major casualties on account of these handicaps in tribal areas. Therefore, apart from the provision of food, provision of safe drinking water should be accorded highest priority. Tribal suffer from poor health conditions. The present state of health of tribal is the cumulative result of under-nourishment compounded by several other factors which include incidence of chronic endemic diseases such as malaria, filaria, tuberculosis, venereal diseases, yaws, leprosy etc. The present health status of tribal is a contributory factor to their numerical decline. There is, therefore, an urgent need to bring such tribal communities within the fold of genetic, preventive and curative medical sciences concomitant with the attempt to improve their nutritional levels. On the other hand regular incidences of different ethnic clashes are the red alarm for the tribal existence. These are the problems and the answer is proper development

communication which can bridge between reach and unreach, grievances and satisfaction, and have and have nots. Before going to enumerate the issues let us discuss some key concepts to familiarize the study area.

### The Tribes of Assam

Assam is merged with mount and plain. Various tribal communities at different levels of acculturation, integration and assimilation the Assamese Hindu society - live in the hills and plains. The great historian of Assam Dr. S.K. Bhuyan once opined that tribal people are very self-reliant in domestic economy and they are less dependent on supplies from outside. The craft here therefore bears the ancient tradition of the ethnic culture, which the people appreciate with pride. They arc out utensils from wood; they spin out cotton and make quilts and traditional apparels. In other words the craft of hill areas is a rare combination of aesthetic and technical sophistication [10].

### Tribal Population in Assam (District wise) [11]

S No.	District	Persons
1.	Barpeta	123,266
2.	Bongaigaon	110,696
3.	Cachar	18,631
4.	Darrang	249,861
5.	Dhemaji	270,496
6.	Dhubri	32,523
7.	Dibrugarh	88,337
8.	Goalpara	131,800
9.	Golaghat	93,920
10.	Hailakandi	821
11.	Jorhat	123,134
12.	Kamrup	250,393
13.	Karbi Anglong	452,963
14.	Karimganj	2,901
15.	Kokrajhar	304,985
16.	Lakhimpur	208,864
17.	Marigaon	120,730
18.	Nagaon	89,394
19.	Nalbari	202,577

20.	North Cachar Hills	128,428
21.	Sibsagar	41,533
22.	Sonitpur	195,083
23.	Tinsukia	67,234

### A list of Tribes of Assam has been mentioned below:

The following are the main tribal communities of Assam:

1. Bodo –Kachari
2. Deori
3. Dimasa Kachari
4. Karbi
5. Lalung (Tiwa)
6. Mishing (Miri)
7. Rabha
8. Barmans of Cachar
9. Hmars
10. Rengma Nagas
11. Sonowal Kacharis
12. Zeme Nagas
13. Hajong
14. Garo
15. Khasi
16. Jaintia
17. Mech<sup>12</sup>
18. Any Kuki tribes including:
  - (i) Biате, Biete
  - (ii) Changsan
  - (iii) Chongloi
  - (iv) Doungel
  - (v) Gamalhou
  - (vi) Gangte
  - (vii) Guite
  - (viii) Hanneng
  - (ix) Haokip, Haupt
  - (x) Haolai
  - (xi) Hengna
  - (xii) Hongsung
  - (xiii) Harangkhwal, Rangkhoh
  - (xiv) Jongbe
  - (xv) Khawchung
  - (xvi) Khawathlang, Khothalong
  - (xvii) Khelma
  - (xviii) Kholhou
  - (xix) Kipgen
  - (xx) Kuki
  - (xxi) Lengthang
  - (xxii) Lhangum
  - (xxiii) Lhoujem
  - (xxiv) Lhouvun

(xxv) Lupheng  
(xxvi) Mangjel  
(xxvii) Misao  
(xxviii) Riang  
(xxix) Sairhem  
(xxx) Selnam  
(xxxi) Singson  
(xxxii) Sithou  
(xxxiii) Sakte  
(xxxiv) Thado  
(xxxv) Thangngeu  
(xxxvi) Uibuh  
(xxxvii) Vaiphei<sup>13</sup>

Now let us discuss about a few selected major tribes of Assam

### **Dimasa**

The Dimasa people from Assam are a part of the greater Bodo-Kachari group. The Dimasas live mostly in the northern half of the North Cachar Hills, an administrative district in the state of Assam in India, including the ravines of the Jatinga valley and the adjoining land.

The Dimasas believe in the existence of a supreme being Madai, under whom there are several Madais including family deities and evil spirits. The religious practices of the Dimasas are reflected in their Daikho system. A Daikho has a presiding deity with a definite territorial jurisdiction and a distinct group of followers known as Khel. Every Dimasa Kachari family worships its ancestral deity once a year before sowing the next rice paddy. It is known as Madai Khilimba. This is done for the general welfare of the family, and Misengba is done for the good of the whole community. The Dimasas cremate their dead. The dead body is washed and dressed in fresh clothes. The corpse is then placed inside the house on a mat for relatives and well-wishers of the family to pay their last respects. In the meanwhile the cremation pyre will be prepared at the cremation grounds which is usually situated by the side of a river or stream. The widow does not tie her hair until cremation.

### **Hmar**

Hmar is the name of one of the numerous tribes of Assam, spread over a large area. The Hmars belong to the Chin-Kuki-Mizo group of tribes, and are recognised as Scheduled Tribe under the 6th Schedule of the Constitution of India. Hmar live mostly in the hills of south

Manipur, Mizoram, Cachar, North Cachar, Meghalaya, Tripura and Chittagong Hill Tracts. Although these areas are within different administrative divisions, they are geographically connected.

The Hmars trace their origin to Sinlung, the location of which is hotly debated. The Hmars are generally short statured, sturdy, dark haired, brown skinned, and known for their bravery. The Hmars still treasure and garner their traditional arts, including folk dance, folk songs, etc., representing scenes of adventure, battle, love, victory, and other experiences throughout history. The majority of the Hmars are cultivators.[14]

All religions consist of a mental attitude regarding the supernatural. The most wide spread manifestation of this attitude is in the shape of beliefs and rituals according to Majumder and Madan, anthropologists. Before conversion to Christianity, Hmars were animist. They were the worshippers of nature. They refer their god as pathien. If any unnatural tree or climber or rock was noticed, the Hmars used to consider them as supernatural. There and then, temporary sheds or Borhmun are constructed. To appease the God, they offer eggs, cocks, zoo etc. The village priest or 'Thimpu' perform the rituals.

From time immemorial, the Hmars believed the concept of three heavenly abodes known as Mithikhou, Pielral and Vanram. The persons who did not live a sinless life go to Mithikhou after death. The spirits of persons, who neither lived a virtuous life nor a sinful life, go to the abode 'Pielral'. It is believed to be a better place than Mithikhou. 'Vanram' is the third abode, which is the real heaven as is believed by the Hmars. Barren women were believed not to go from Mithikhou to Pielral. Men who has not killed enough ferocious animals in life time will not go to Pielral from Mithikhou.

### **Kuki**

The term Kuki people refers to Zo ethnic entity that spreads out in a contiguous region in Northeast India, Northwest Burma (Myanmar), and the Chittagong Hill Tracts in Bangladesh. The Kukis have numerous types of culture and tradition since their forefathers' times. They are unique, interesting, and impressive. Rice is the staple food of this people. They domesticated a

number of animals, which some of them are very useful and helpful to their masters.

### Bodo

The Bodos are an ethnic and linguistic community, early settlers of Assam in the North-East India. Bodos belong to a larger group of ethnicity called the Bodo-Kachari. The Bodos are recognized as a plains tribe in the Sixth Schedule of the Indian Constitution. Kokrajhar town is considered the nerve centre of the Bodos.

Very early on, Bodos may have introduced rice cultivation, tea plantation, pig and poultry farming, and silkworm rearing in the North East India. The traditional favourite drink of the Bodos is *Zu Mai* (*Zu*:wine, *Mai*:rice). Rice is a staple of the Bodos and is often accompanied by a non vegetarian dish such as fish or pork. Traditionally Bodos are non-vegetarians. Weaving is another integral part of Bodo culture. Many families rear their own silkworms, the cocoons of which are then spun into silk. Bodo girls learn to weave from a young age, and no Bodo courtyard is complete without a loom. Most women weave their own *Dokhnas* (the traditional dress of the Bodo women) and shawls. The Bodos are also expert craftsmen in bamboo products.

In the past, Bodos worshipped their forefathers. In recent years, Bodos practice Bathouism, Hinduism. Bathouism is a form worshipping forefathers called Obonglaoree. The *siju* plant (belonging to the Euphorbia genus), is taken as the symbol of Bathou and worshiped. In the Bodo Language *Ba* means *five* and *thou* means *deep*. Five is a significant number in the Bathou religion.

A clean surface near home or courtyard could be an ideal for worship. Usually, one pair of Betelnut called 'goi' and betel leaf called 'pathwi' could be used as offering. On some occasion, worship offering could include rice, milk, and sugar. For the Kherai Puja, the most important festival of the Bodos, the altar is placed in the rice field. Other important festivals of the Bodos include *Garja*, *Hapsa Hatarnai*, *Awnkham Gwrlwi Janai*, *Bwisagu* and *Domashi*. Despite the advance of Hinduism amongst the Bodos, mainstream Indian practices such as caste and dowry are not practiced by the majority of Bodo Hindus who follow a set of rules called Brahma Dharma.

### Mishing

The Mishings are an ethnic group inhabiting the districts of North Lakhimpur, Sonitpur, Dhemaji, Dibrugarh, Sivasagar, Jorhat, and Tinsukia of Assam. A few live in and around of East Siang district of Arunachal Pradesh. They were earlier called Miris, to which they take offence now. However the Constitution of India still refers them as Miris. Permanent cultivation is generally practiced though shifting method is not fully given up. Crops mainly grown are paddy, maize and mustard with varieties of potatoes and edible green leaves. Mishings are expert fishermen. Fishing is a favorite occupation. No period is set apart, yet winter is the best season. Fish are caught with net; traps, hooking and poisoning the water while turtle are punched with a hard and polished bamboo stick fitted with iron tip.

### Deori

Deori community has a notable culture and tradition which is a hidden treasure for the sociologists. The Deoris represent the class "priest"-a section of the whole Chutia community. In the first two decades of 13<sup>th</sup> century, before arrival of the Ahom, the empire of Chutias was spreading towards the river Subansiri (a tributary of river Brahmaputra, which is in upper Assam). Chutias are the tribal of Tibet-Burmese. In the first decades of 16<sup>th</sup> century Ahom invaded Chutia's empire and captured their state. Some of the Chutia people fled away to avoid terrorism but some of them managed to keep marital relationship with the Ahoms.

### Education and beliefs among Tribals of Assam:

#### Educational level and ST

Sl	Age groups	Population	Without educational level	Below primary	Primary	Middle
1	0-6	552,116	0	0	0	0
2	7	84,717	678	49,559	0	0
3	8	106,967	794	69,122	0	0
4	9	72,219	449	49,001	5,674	0
5	10	111,436	802	57,450	25,327	0
6	11	54,634	271	18,576	26,816	0

7	12	110,287	700	25,322	53,261	7,825
8	13	68,142	423	9,396	33,220	13,952
9	14	88,875	622	9,249	29,168	33,393
10	15	80,968	661	7,268	17,705	29,143
11	16	89,494	781	6,842	15,265	28,645
12	17	46,403	414	3,193	6,522	13,227
13	18	103,084	1,301	7,569	14,381	24,645
14	19	41,282	501	2,833	4,885	8,884
15	20-24	294,227	4,302	20,521	33,154	52,530
16	25-29	292,989	5,391	24,432	30,908	40,972
17	30-34	240,692	4,917	24,091	23,984	25,479
18	35-39	234,350	5,251	28,060	24,269	21,908
19	40-44	157,357	3,833	20,669	16,474	13,136
20	45-49	135,910	3,391	18,887	15,008	11,049
21	50-54	95,490	2,532	13,576	9,901	6,633
22	55-59	70,133	1,782	10,391	6,925	4,332
23	60-64	65,226	1,730	9,281	5,433	2,671
24	65-69	42,058	1,064	6,493	3,651	1,573
25	70-74	31,743	815	4,720	2,473	855
26	75-79	15,489	435	2,452	1,267	490
27	80+	19,242	508	2,577	1,329	477
28	Age not stated	3,040	400	273	194	168
29	All ages	3,308,570	44,748	501,803	407,194	341,987
Sl	Matric Second.	Higher Second.	Non-technical diploma	Tech. diploma	Graduate and above	Unclassified
1	0	0	0	0	0	0
2	0	0	0	0	0	27
3	0	0	0	0	0	26
4	0	0	0	0	0	4
5	0	0	0	0	0	7
6	0	0	0	0	0	2
7	0	0	0	0	0	2
8	0	0	0	0	0	3
9	0	0	0	0	0	0
10	9,496	0	0	0	0	0
11	18,964	0	0	0	0	2
12	14,310	0	0	0	0	0
13	25,401	4,197	0	36	0	3

14	11,650	3,434	1	26	0	1
15	69,443	23,530	6	260	6,277	5
16	54,466	17,074	4	289	9,543	16
17	36,661	11,065	18	249	7,705	15
18	29,141	7,565	11	159	6,045	4
19	15,859	3,608	2	100	3,759	5
20	11,492	2,254	3	57	2,541	4
21	6,488	1,169	2	35	1,537	6
22	3,748	549	2	26	800	3
23	2,132	252	0	16	433	3
24	1,130	122	0	8	222	4
25	679	68	0	4	130	4
26	414	41	0	1	57	1
27	415	61	2	5	50	2
28	176	47	0	0	25	0
29	312,065	75,036	51	1,271	39,124	149

From the above table, it is clear that the educational level of the tribal communities of Assam is not up to the mark. According to the 2001 census, only 39,124 tribals have graduation or higher degree, which is about 1.18% of total tribal population of the state. So, it recognizes one of the major root causes of the underdevelopment of the tribal communities of the state. Among the total population 1723428 no. of persons are literate, which is around 52%. It can be noticed that among these 52% literates, more than 55% are under matriculation. So, communicating science to a large segment of the tribal community is really a challenging task. Here we can see the reality of the tribal society and their belief on non scientific issues. For example we can discuss about the health practices among the tribal societies of Assam.

Health is a resource for everyday life, not the objective of living. Health is a positive concept emphasizing social and personal resources, as well as physical capacities. A disease or medical condition is an abnormal condition of an organism that impairs bodily functions, associated with specific symptoms and signs. It

may be caused by external factors, such as invading organisms, or it may be caused by internal dysfunctions, such as autoimmune diseases.

Since the bulk of the tribal population dwell in villages, their traditional dietary pattern has hardly changed for which has great impact directly or indirectly on the health and nutrition of the tribal. There is a deep relationship between herbs, herbal medical man and the tribal society.

Karbis are one of the dominating tribal communities of the hills area of the state. The researchers have visited a few Karbi villages in the Karbi Anglong district as well as in the Kamrup district. Karbi Anglong is the hilly district and Kamrup is basically plain district. The researchers visited Taralangshu, Dikrenglangshu villages in Karbi Anglong and Birkuchi, Japarigog, Sonapur, Maina Khurung etc. areas of Kamrup district. The researchers found that all the Karbi people in hill as well as plain are strictly following their age-old practices for health care. Although the plain Karbis are also acquainted with the modern medical facilities, as they are residing near Guwahati city. The following is the method of diagnosis of diseases, which still alive in the remote Karbi society.[16]

### **Mode of diagnosis**

1. Feeling the patient's pulse of heart beat is the first step of the diagnosis.
2. Rishubasa (traditional healer) cuts a piece of Ginger in front of the patient and decides which evil power has attacked him by watching the changing colour of that ginger piece. After that he can decide what Puja is suitable to give relief the patient.
3. There is another process to determine the ailments by cutting the neck of a hen by a bamboo cut piece and the blood is spreading up on the earth. Examining the bloodspot on the earth, Rishubasa can decide the proper treatment to the respective disease. In this way he can also determine the sex of a baby before getting born.
4. He also wants information from the patient before attacking the disease where he/she went. Is it the place for hunting a bird or any thing else? After getting satisfactory answer he decides the degree of the disease[17]

### **Different Deities for Treatment**

Rishubasa detects the malaria or typhoid after his empirical investigation he starts to worship the God "Murti" or the god "Check Kara". Banana leaves, bamboo stick, local rice beer, betel are used. Sacrifice of pig or bird is necessary. Hemphu is worshipped for the sake of good health of the pregnant lady and her coming baby.

Rishubasa as claimed by him can cure even after 10 to 12 days of dog biting. To cure such a patient "mantra" is uttered with a plate made of bell metal. The plate begins to move to the spot of dog had bitten and sticks there for a few minutes. When entire poison is sucked, the plate falls off and man gets cure.

Snakebite is frequent occurrence among the tribal people who reside in jungle or hilly tracts. A tribal person has a strong belief that snakebite can only be cured by magic chants and application of herbal preparation. To cure the nose bleeding the patients allow to inhale the smoke produced by burnt dry cow dung. To get quick improvement from fine burn, they give a coating of egg albumen over the burnt place.

Rishubasa possesses tremendous knowledge regarding healing practices and have proved to be successful in treating very chronic diseases like malaria, stomach problems, gynecological problems small pox, dog - snake bites etc. He is the only source of support and hope for survival of that hamlet. Basing Terang got medical lessons from his father late Maupa Terang and he is giving an informal training to his elder son Holy Terang. While Transferring the traditional health care knowledge of his own ethnic group, the master medicine man (father) takes adequate care to teach the learner (son.). The conveying of information about medicinal plants goes after the religion and culture which is not only orally transmitted from generation to generation but also exist undocumented form and is purely ecosystem and community specific.[18]

### List of God & Goddess

Sl.	Name of God & Goddess	Function
1	Lamki	Removal for inter & intra society violence
2	Dubari	To protect the boundary of own house
3	Chitang arlam	Puja for power & success
4	Panjok	Worship for pregnant women
5	Pirtu	Child diseases
6	Dar	Snake bite
7	Rit	angling Cultivation
8	Lonley	Increasing the fertility of cultivated land
9	Chack	clim kanthur Nourishing the plant
10	Burkamatha	Family protection
11	Karjong kekur	Peace for soul
12	Munjil arur	Increase the age limit
13	Cha meme	For giving birth a child[19]

### Name of the evil spirits

Sl.	Name of evil spirit	Function
1	than debota	Disaster
2	Check ama	Unknown diseases
3	Nihu	Maternal uncle do it to cure the unknown diseases of the children of his sisters [20]

### Rituals Concerning Physical Phenomena

#### Conception of soul (Kaijong)

Belief in the existence of soul is one of the central concepts of the Karbis, from which they have built up a canopy of beliefs, myths and of rituals concerning the life of man with all its uncertainties and anxieties. This soul or 'jueu' or 'jiva' as they described it in Assamese may be called the non material aspect of human personality. Everybody encompassing all living beings, had should which is given by Lord Jom (and which is genuine soul). So long as a man has his own should he is healthy and living. Gut if by any chance he happens to loose his own real soul due to the malice of certain evil spirits the person will either become seek or evil die, they perform karjong Avor-a ritual, which seemed to be very common among them to invoke the real soul of the person. When the real should not return to the man he may die.

Their concept of 'jieu' or soul (karjong) cannot be identified with the physical existence. On death, the soul leaves the mortal human frame as of my informants puts it, and begins its journey to the Jom Arong-the abode of the dead-the kingdom of Lord Jom. At their funeral rites, 'karsahe'-(funeral song) is sang by some female



relative of the dead person indicating the way the soul is to travel.

In case of death much emphasis laid on natural and unnatural death. The souls of the persons who i.e. unnatural death normally cannot go to Jom Areng, but special rituals can redeem their should except in the space of a person killed by a tiger is eternally doomed and nothing can be redeemed the soul[21]

### **Re birth**

Their concept of the soul leads to the belief in reincarnation. They believe that when a child is born, it is the soul of a dead ancestor reincarnated. After the birth of a child they try to determine that particular ancestor whose soul has reincarnated and the child is named after the dead ancestor's name.

### **Belief in Evil spirits**

The peoples of Decrenglanshu, find themselves surrendered by a hoist of evil spirits who are believed to be higher than man but lower than the higher gods. These malevolent spirits often misdeed or kidnap the real soul of a man making him ill. An 'Ahiii' is a female spirit who tries to eat the fetus-leading to complications in child birth. Other common evil spirits are 'Bhoot' Pichach, Kumbhir (who resides below the earth) soitan, phrase deo (pogola devata), pharkong.

Sometimes, these spirits kidnap the real soul of a man and replace it with a fake one making the man sick. People are afraid of these spirits and whenever they are in any danger they use divination to ascertain which spirit is involved and also the god who is willing to help the man. They do not usually worship these in the since they do with supreme gods-but make some offerings and sacrifices just to keep them satisfied. [22]

More than fifty years of independence of the autonomous district, that tribal development could be seen as anticipated by the policymakers. The tribal clans remain more or less self governing local communities and are still depending on their on traditional culture.

We cannot ignore that these types of beliefs are still alive among the tribal communities in the country. After 65 years of Indian independence these indigenous people do not get the light of modern life. So, integrated approaches are necessary for the improvement of

the tribal community. The society has a set of predetermined customary rules. For an outsider, some of the customs or customary rules may not be sound, logical and good. But for the tribal society itself they are quite good since they mean or judge things according to their own cultural values and ethics. In plan for improvement, the planners must take these things into account if they want to have the desired results.

### **Challenges ahead**

#### **(I) Improvement in the quality of life: Need health Awareness**

One of the long-term needs for tribal development is improvement in their quality of life. Certain basic services like drinking water, health- hygiene, housing, nutrition, communication etc. need to be provided to them. The problem of drinking water in tribal areas is acute. Further, some villages suffer from contaminated water supply. Sanitation and hygiene are major casualties on account of these handicaps in tribal areas. Therefore, apart from the provision of food, provision of safe drinking water should be accorded highest priority. Tribal suffer from poor health conditions. The present state of health of tribal is the cumulative result of under-nourishment compounded by several other factors which include incidence of chronic endemic diseases such as malaria, filarial, tuberculosis, venereal diseases, yaws, leprosy etc. The present health status of tribal is a contributory factor to their numerical decline. There is, therefore, an urgent need to bring such tribal communities within the fold of genetic, preventive and curative medical sciences concomitant with the attempt to improve their nutritional levels.

A state mechanism can not supply all these to the millions of tribal, but the scientific awareness may be created to improve their quality of life.

#### **(II) Raising the levels of productivity: Need Agricultural Awareness**

Raising their productivity in agriculture, horticulture, animal husbandry, forestry, cottage, village and small industries and provision of employment in all seasons will go a long way in reducing the incidence of poverty of Scheduled Tribes. However, creation of employment potential during the slack season is a prime need

to ward off starvation for a few weeks in a year, which is a normal feature in some tribal areas. There should be provision of capital inputs, technology, marketing, training etc. to augment production in tribal areas. Implementation of effective programmes may go a long way in removing poverty to a great extent. There is, thus, a continued emphasis on raising the levels of productivity and creation of employment opportunities. This, in turn, will call for higher investment by way of special central assistance, flow from state plan, from financial institutions and central sector projects. This is inevitable as with increased price levels, a much higher investment would be necessary for a family in order that the assistance can have a dent on poverty and enable the family to have a sustained but reasonable level of income to cross the poverty line.

### **(III) Removal of Illiteracy: Need Educational Awareness**

Removal of illiteracy is an important component of tribal development. The educational level of tribals is very low. Further, the insignificant literacy rate among tribal women is of great concern. Illiteracy gripping the tribal female-folk distorts the female role models. It perpetuates ignorance and superstition among them. The socio-economic development of Scheduled Tribes depends on educational advancement. Education is more than a mere asset for some tribal communities; investment in education is, in a way, crucial for their existence. Continued economic exploitation has brought them to a state of helplessness exemplified by migrant labour, debt bondage, etc. A medium of education will equip them to deal with middlemen, merchants and traders on a better footing. The adults need to undergo citizenship training to understand the process of law, revenue, police, forest and in fact, of the entire administration to remove their present disadvantage. On growing up, the educated tribal children can face the modern world better.

Elementary and middle education has to be made more functional and relevant for them. The norm for establishment of a school should be subject to scrutiny by the state governments in the light of the scattered population in tribal areas and the low rate of literacy among the tribal communities. The schools must give their

stress on the popular science, that can help the school dropouts in future life.

### **Educational Reforms:**

A large majority of school of teachers of the tribal dominated area lack training and adequate education. Therefore, they are not intellectual alive and keen in their duty. In Karbi Anglong district, there is no teacher training center. Hence the teachers have to undergo training in the different basic training centers of the state. It is difficult on the parts of the local teacher to take training in the state. It is difficult on the part of the local teachers to take training in the distance places. A large section of the school teachers have taken the jobs not from any sense of a vacation but of any noble aim for sheer economic necessity. The proper selection of teachers and paying them adequately for the maintenance of a reasonable standard of living will be the main solution of the problem. It is observed that this district has not been able to provide 'trained' teachers to all the primary schools and a large number of teachers are still untrained.

The efficiency suffers, the quality gradually goes down. The chief educational input in these schools is the large member of non matriculate teachers. Most of the school teachers of the district are non-matriculate and non-trained. Due to distance difficulty a section of the local teachers one reluctant to undergo training outside the district. In addition to this the chief reason of the non availability of the desired number of teachers is the fact that there is no such number of educated persons to meet the need of the district. In such type of condition the teachers should be encouraged to increase their qualifications or they should be sent to training institutions on government expenses. They should be provided with more facilities and be attracted to teaching work by making them realize to raise the standard of teaching. In order to implement it the two or three of training schools should be established in different parts of the district. It is also necessary that the schools should be given liberal grant in aid to enable them to purchase teaching implements because enthusiastic and trained teachers generally find it difficult to do much in the field of education without them.

It is hard to solve this complicated problem of mother tongue in this hilly district as languages (English, Bengali, Assamese, Hindi, Bodo &

Karbi) are used as the media of instruction in different schools of the district. Being a multimedia district in respect of the medium of instruction the little children of the primary schools have to face tremendous difficulty in learning their lessons. As for instance the Karbi children speak Karbi in their home and day to day life and have to learn lessons in Assamese or in the English medium which are foreign language for the little children. So it is hard row for them in gaining the elementary knowledge of various kinds. So the language part should be considered. Textbooks in mother tongue for children at the beginning of the primary education cycle, where they do not understand the regional language. Suitably adapt the curriculum and make available locally relevant teaching learning materials for tribal students. The help of National Council of Educational Research and Training and the constituted State Council of Educational Research and Training will be needed to prepare study material in tribal languages.

Adult education centers for tribal women should be started separately and only local educated tribal female teachers should manage these. These centers should function only during the slack agricultural season. This will ensure confidence among the tribal women and also ensure regular attendance.

Supply of textbooks, popular science tools, instruments, uniforms and midday meals in the primary schools although has made some headway in the schools located in tribal areas of Assam, all schools as well as all tribal students are yet to be covered. More coverage will surely help to further advancement of the level of literacy among the tribal girls because of the fact that such amenities serve as incentives.

#### **(IV) Elimination of exploitation: Need general Awareness**

Elimination of exploitation and enforcement of protective and anti-exploitative measures are the basic needs of tribal development. Exploitation of tribals forms a *lait motife* in the tribal canvas of today. Sometimes, the unscrupulous elements under one cover or another exploit the simple tribal situation. Exploitation in tribal areas mainly occurs in the fields of liquor vending, land alienation, money-lending, forestry, trade including collection and disposal of minor forest products and labour

including forest labour. While generally the passing of lands from the ownership and control of the tribals is ascribed to the lacunae in the law, faulty implementation, rapacious exploitation by unscrupulous traders, moneylenders etc., sometimes the tribals are overwhelmed by a sense of alienation from the socio-political system itself, which they think is responsible for their massive dispossession. There are numerous problems that the tribals are facing today of which economic crisis and poverty come to the forefront. It is through the traditional money-lending system that the tribals are greatly exploited. Indebtedness is, thus, the next pressing problem of these areas. The tribal economy is characteristically a subsistence type of economy. Due to their traditional hedonistic type of world view, they have very little savings. Naturally, when they are in need of money, they are forced to depend on others particularly on the non-tribal moneylenders.

#### **(V) Supportive Infrastructure in Tribal Areas: Need alternative Communication Media**

Another need for tribal development arise from the fact that the tribal areas have sparse physical infrastructure. Whatever exists might not be able to support beneficiary oriented programmes. These are poor in the matter of physical and mass communication. Adequate infrastructure is required for production, anti poverty, education and anti-exploitative programmes. Supportive infrastructures have to be legislative, physical, institutional and administrative. Among items of physical infrastructure, special emphasis should be given on minor as well as lift irrigation, soil and water conservation, cooperation and land reforms, which support beneficiary oriented programmes. Capital intensive sectors like large and medium industries, roads and bridges, mining, power, road transport may be given somewhat lower priority unless their spin off effects as such will have a great economic impact on the tribal economy.

#### **(VI) Exploitation of vast natural resources in tribal areas : Need Scientific Awareness to use natural resources**

Another factor, which necessitates tribal development is that there are vast natural resources waiting to be tapped in shape of water,

soil, forest, minerals in contradiction to some developed areas of the country. Where they have already been tapped or where such natural opulence is hardly seen, these abundant natural resources should be tapped for all round development of tribal areas.

### **Communicating Science**

Now inculcating scientific awareness and popularising science for better livelihood, is the need of the hours for the indigenous tribal communities of the state. For this purpose the following ways may be adopted.

#### **1. Folk Performance:**

The tribal communities of Assam are very rich in their folk and traditional materials. They have their own performing arts; such as – theatre, drama, dance, songs etc. Folk performances containing science materials are the prime tool for science communication among the tribal communities. The folklore phenomenon in the region represents as a tool of communication by employing verbal, non-verbal, musical and visual folk art forms, transmitted to a society or group of societies from one generation to another. These are indigenous modes and have served the society as tools of communication for ages. Therefore, among the tribal communities in Assam, folk media offer an important apparatus in the process of inspiring rural masses towards accepting social changes, which also establish a constructive means for the upliftment of the tribal people and can build a scientific temperament among them. But, it will not be accepted, if simply a modern scientific message is incorporated in the performances. For that purpose the following model may be adopted.

1. Identification of the objectives
2. Identification of the folk/ traditional media of a tribal community
3. Selection of the scientific message, that will be disseminated
4. Translation of the message to the local language/dialects
5. Interpretation of the message and use of local proverbs/ dialogues/ concepts, which are popular among tribal people.
6. Composition of the music, tune, set, instrument etc. and fit the new message (content) in it.

7. Modernization of the performing skills for attraction.
8. Selection of a team and a group leader for final performance.
9. Train up the members of the team & rehearsal
10. Performance
11. Impact assessment
12. Further modification for better result

#### **2. Games:**

Tribal people are fully depended upon social custom, superstition and other social rules. Among many tribal societies, there are no native changes on the period to use the scientific thinking. One can see their traditional dwellings and in their livelihood, but they use less modern techniques. It is only because of the fact that there is no impact of proper education in them. If among the tribals, the present picture of their society and cultural position was improved then they had to minimize their superstitions and customs prevalent in them.

To draw the interest for learning, folk games may be modernised and science based games may be exhibited in public places, especially in the market areas. Using the science kits and scientific magic we can draw the interest of the children and the youths. For this purpose a group of qualified tribal youths is required and they may be trained up for the purpose.

#### **3. Public Speaking**

Definite provisions for the welfare and uplift of the - tribal people throughout the country. Articles 15 (4) 46, 244 (1) and 339 of the Indian constitution speak of special provisions meant for the administration and control of scheduled areas and tribals therein, for their welfare and protection. We should try to train and build up a team of their own people to do the work for popularisation of science. Some technical personnel from outside will no doubt be needed especially in the beginning. But we should avoid introducing too many outsiders in to tribal territory.

Interpersonal communication and public communication are always effective in nature. With provocative and attractive public speaking, science can be popularised. But it should be in local dialect or their respective tribal language. Modern gadgets like LCD projectors, slides,

animation, cartoons etc. may be used in the time of lecture.

#### 4. Community Media

Media should promote socio-economic development of the country. Media should uphold the unity and integrity of the country and the democratic and social values in the Constitution. It should promote equality and fraternity among people and act as catalyst in strengthening the cohesive forces and in weakening the decisive forces. Emphasis should be given on commercial ethics and not encouraging unnecessary consumption. Media must play its role as an instrument of social changes and national cohesion by upholding progressive values and involving the community in a free dialogue. It must play a major role in development, especially in conveying informative and persuasive messages to the public.

Although, it is not possible to the mainstream media to cover in tribal languages in a state like Assam where many tribal languages are there. So, community media may be the best alternative. Community news papers in local language, community magazines, community radio etc. may be used to popular science.

#### 5. Exhibition

On behalf of the science cities, science museum exhibition can be organized for tribal people with demonstration in their own language. Mobile exhibitions, mobile medical units, boat clinics etc. may be used in this regard.

#### 6. Science Material Development

The tribal female education is lagging behind and is needed to be recognized at first. In the far-flung pockets the level of women's literacy is very weak. So, first identification of the problem is necessary. Tribal women of the region can not be placed under one category and that their problems will have to be considered in the context of time, space region, socio cultural, political upheaval family system, village or community or organization etc. The tribal differ from one another in such respects as racial traits, social organization, cultural pattern languages, religion, customs, beliefs, and so on. Traditions socio-cultural norms, religious activities and other ethics differ widely in different tribal areas.

#### Conclusion

It has been found, change in society depends to a large extent on the prominent factors like industrialization, modernization, but from the analysis of the findings it is clear that change in attitude and values of the people definitely play a major role in changing the ways of living of the people. Same has happened in tribal society also. The in migration and out migration, inter relation between inter- tribe, intra tribe, inter caste community, interaction from communal harmony cultural exchange with differential states and nations are contributing in the changing process of the society.

It is true that to improve a tribal society they must be enlighten by the innovations in the field of science and technology. The effort to empower tribal people towards taking the benefit of science for the society's welfare comes to a naught when society mirrors a wide gap between scientific community and the common mass. It is, because, the language in which the science community speaks is generally incomprehensive to the common man and especially to the tribal people. To put it very briefly, there exist a communication gap between the science community and tribal common mass. This gap needs to be bridged. It may take long time and great effort to get rid of old misbeliefs and superstitions of the tribal communities and create an environment where science is compatible to them. But it is to be done. And here science communication plays the pivotal role. In order to create and sustain scientific temperament among the tribal community, a movement of this sort is needed. The young generations of the tribal communities are to be trained up to utilize the common infrastructure to popularize science among all members of their community.

#### References

- [1] Bhushan, Chandra, Terroris and Seperatism in North East India, (Kalpaz Publications, Delhi, 2007), p. 65.
- [2] Bhuyan, A.Ch., (Chief Editor), Political History of Assam, Vol.-III (Publication Board, Assam, 1999) Second Edition.
- [3] Gopalkrishnan, R., Insurgent North Eastern Region of India (Vikas Publishing House Pvt. Ltd., New Delhi, 1995), First Edition. p. 2

- [4] Bhagawati, A K ; Bora, A K , Kar, B K , Geography of Assam, (Rajesh Publication, New Delhi, 2001). p 115
- [5] Tribes & Culture, online available at <http://karbianglong.gov.in/tribes-culture.htm> accessed on 21.1.2007.
- [6] Area profile of Assam, Census of India 2001, online available, accessed in September 2009.
- [7] Indian Tribes, online available at [www.ecoindia.com/tribe](http://www.ecoindia.com/tribe), updates 2008, accessed on 28.07.08.
- [8] Remote Tribes of India, online available at <http://www.magical-india.com/package-detail.asp?id=14&landcat=1>, accessed on 28.07.08
- [9] Tribal Population of India, Census of India 2001, online available, accessed in September 2009.
- [10] Akin, Jennifer. "Media Strategies" in Beyond Intractability. Eds. Guy Burgess and Heidi Burgess, (Conflict Research Consortium, University of Colorado, Boulder, March 2005).
- [11] Tribal population, Census of India 2001, online available, accessed in September 2009.
- [12] Bordoloi, B.N., Sharmah Thakur G.C., Saikia, M.C., 1987, T.R.I, Popular Series – Tribes of Assam, Part–I., pp. 1-17.
- [13] Mishra, B.P., Early History of Pragjyotisha-Kamarupa: Some Reconsideration Lecture Series – 5 (ICHR, NE Regional Centre, Guwahati, 2007) pp. 5-9.
- [14] Herman & Chesney, 1998. p. 2-3, cited by Mahanta, N. G., in Terrorism in Assam, (Gauhati University), 2006.
- [15] Educational level of STs of Assam, Census of India 2001, online available, accessed in September 2009.
- [16] Ray, Anamika, The Role of Communication Agent in Development Process, (Visva Bharati, Santiniketan), 2009.
- [17] Ibid.
- [18] Ray, Anamika, Traditional Healing Practices: A Balance Between Folk Medicine And Folk Rituals, (DST sponsored seminar at Visva Bharati, Santiniketan), 2006.
- [19] Ray, Anamika; Dutta, Ankuran, Community Participation In Development Process A Case Study Of Karbi Traditional Healing Practices - A Bridge between the Ecological and Social Process, (National Seminar organized by Dept. of Sociology, Dibrugarh University, Dibrugarh), 2006
- [20] Ray Anamika, Ray Manas; The Communication gap : A case study on the medicinal practices of the Karbi tribes of Karbi Anglong district , Assam (Bidisha); 2005
- [21] Ray, Anamika; Dutta, Ankuran, Community Participation In Development Process A Case Study Of Karbi Traditional Healing Practices - A Bridge between the Ecological and Social Process, (National Seminar organized by Dept. of Sociology, Dibrugarh University, Dibrugarh), 2006
- [22] Ibid.
- 
-

## Diversity of Marine Life Forms Based on Discards of Fishing

B. Padmavathi and A. Padmaja  
Indira Priya Darsini School, Bhogapuram,  
INDIA

**Abstract.** There is around 70 % of Sea Water on our Planet Earth. There will be total darkness under 2200 Mts depth. Even in these dark areas upto 60 Mts around 2000 species of Living beings like Algae AND Sponge exists. 3.5 % of salts present in sea water. Sodium, Magnesium and Potassium salts which we use are from sea. Oil and Natural Gas deposits are under the bed of the sea. Around 0,000 fish fauna exist in Oceans. 60 Lakh people are surviving on the fishing industry. Bu the waste produced by mankind is terminating the fishing business line causing financial loss to the people living on the fishing business. Some fish lay eggs at the face of rivers in sea water. If we can stop polluting water at that places we can save fish fauna. Industrial effluents causing sea water pollution is to be stopped and a wide publicity is to be conducted on that issue. India has three coastal lines. Till now 2,500 species of fishes have been recognized in World Mega Diversifiable countries. India stands 9th. Among them 1600 species were living in sea water. The fisherman take out use full fish from their nets and leave the non-commercial species plucked to their nets will be left out. Seasonally fishes are available to fishermen and the knowledge base was given to fishermen under this project. Main objective is to educate fishermen to leave the non commercial Tortoises, and fish in to sea waters. Government has to educate fishermen not t be use Mechanized boats. The availability of fishes at the distances, and types of fishes that are available to be educated by the Government. And to let them understand the ecological balance of fish fauna and Government had to take steps to provide nets and the correct mode of nets to be used for fishing specialized fish fauna. The fishermen are to be guided by fisheries department officials. In the light of this project, campaign was conducted with the guidance of fisheries department officials. AS per the Guidelines the fishermen are requested to stop fishing in the Months May/June as the periods

are reproductive stage of fish fauna in the oceans.

---

---

## Study on Phase Change with Natural Convection – A Hands-on Approach of Acquiring Insights of Complex Physical Phenomena

A. Das and D. Sanyal  
Chemical Engineering Department, Jadavpur  
University, Kolkata 700032, Central Glass  
and Ceramic Research Institute, 196 Raja S.  
C. Mullick Road, Kolkata, INDIA  
abhishekdas000@gmail.com,  
sanyald@gmail.com

**Abstract.** Solid-liquid phase change accompanied by natural convection encompasses a broad range of physical phenomena in natural and engineering sciences. Convective phase change phenomena play a singular role in controlling the dominant environmental issues of modern times, such as, melting of glaciers and polar ice caps which gives rise to oceanic currents and anomalous change of weather. Similarly, the frontiers of technological innovations related to fabrication of advanced engineering materials and systems, such as, growth of semiconductor single crystals, cooling of IC (integrated circuit) chips etc. depend greatly on precise understanding and control of the physics of phase change. While major strides have been taken to study phase change phenomena using modern experimental and computational tools, a basic appreciation of the fundamentals behind phase change phenomena need to be developed and disseminated to students and researchers of science through simple hands on approach. In this paper, we have attempted to devise simple experimental and computational tools for making basic understanding of phase change behaviour of materials undergoing melting-solidification phase transitions coupled with natural convection. The concept of thermal buoyancy driven convection with thermal gradient parallel and anti-parallel to the gravity vector has been illustrated with experimental studies on aqueous systems to generate Rayleigh and Rayleigh Bernard convective patterns respectively. Using nematic, cholesteric liquid crystals, the visual

display of thermal fields and the evolution of the convective flow patterns have been videographed with passage of time. The physics of flow under the given initial and boundary conditions have been further illustrated with the help of accurate computer simulations of the phenomena and comparison with the experimentally observed phenomena. For studying phase change with natural convection, simple experiments have been designed and performed with pure water and eutectic aqueous solutions of inexpensive inorganic materials, such as, ammonium chloride and sodium carbonate in cavities of various aspect ratios. The phenomena of density inversion in water at 3.98 °C and the associated anomalous convection during freezing of water have been illustrated experimentally in these experiments and the physics has been explained with the help of computer simulations. The effect of composition of a binary alloy system on phase change phenomena giving rise to sharp or diffuse phase change interface has been depicted clearly with the help of melting-freezing studies on eutectic and off-eutectic aqueous inorganic systems. The explanation of complex, interaction between the macroscopic events, such as, natural, thermal convection and the microscopic events such as solute partitioning for alloys have been provided by a combination of video images of the thermal states captured using colour changing liquid crystal tracer particles and computer simulations. Finally, the effects of various parameters, such as, the initial and boundary conditions, the thermo-physical properties, the aspect ratio of the cavities on phase change accompanied by natural convection has been illustrated with the help of both experimental and simulation studies.

---

---

## Science and Technology Communication and Science Literacy

S.J. Bute

C-2, Chetak Housing Society, Mumbai Pune  
Road, Khadaki Station, Khadaki, Pune-  
INDIA

swatijbute@gmail.com, swatibute11@gmail.com

**Abstract.** Ever met a small child for whom this whole world is a great mystery? An infant, who has the capacity to only observe, tries to know about each and everything around. By looking at them, touching them, kicking them, tasting them, throwing them on the floor just to see what happens. And when they grow up, the kids have the question WHY ready for almost everything. What does it exactly mean? It means that the basic concept of Science... 'What, Why and How' is nothing which we adapt from somewhere outside, but it is something we are born with and keep exploring in every aspect of our life. The word "Science" comes through the Old French, and is derived in turn from the Latin *scientia*, "knowledge", the nominal form of the verb *scire*, "to know" and definitely knowledge can not be confined within science laboratories or big scientific institutes or seminars. It needs to be spread out to benefit everybody. Unfortunately, many of us do not have that level of awareness or more precisely do not have the willingness to acknowledge that Science belongs to everybody irrespective of college degrees we have achieved, scientific seminars we have attended, research papers we have gotten published. Separating Science from each and every aspect of our life will be like separating soul from the body, as they can not exist without each other. When we talk about taking Science to people, who are not aware that Science is an inseparable part of our daily life, the onus of starting the process is on science literates who can use scientific knowledge and scientific ways of thinking for individual and social purposes. Thus, science literacy encompasses not only the knowledge and understanding of scientific ideas and processes, but also, crucially, the ability and desire to apply those ideas and processes. Increasing the public science literacy requires much more than the transmission of information; it must also change people's attitudes and



actions. Why science literacy is required? Science literacy is not only required for responsible and sustainable development but it is also required for the growth of human civilization. Communication is the basic need in human society. It is a universal phenomenon which is both ubiquitous and equivocal. All act of sharing ideas; experience and knowledge have been commonly stated as communication process. In reality communication is a unifying force which facilitates social, interaction, integration and movement. Communication also breaks the knowledge monopoly and introduces the realities of the world to the people. The term science communication literally means communication of science. Science communication would require something scientific or relating to science to pass back and forth between recipient(s) and the communicator. There can be several categories of science communication depending on which the communicators and the recipient(s) are, as also what the nature and level of science involved. Science can improve things greatly and that is why we should be optimistic about its capacity to change living conditions in poor countries. Whether it is in rich or poor countries, the public has to be informed about science and technology activities. Since direct contacts between science and technology organizations and the public are few and far between (perhaps almost nil in many cases) the media have to discharge this fundamental duty of Science Communication. Media of communication thus acts as a mirror of society, but at the same time, it has also been employed by man as an instrument of social and technological changes. However, there is a need to properly harness media of communication through media persons and media organizations suitable to peoples need and aspirations so that communication gets democratized for development purposes. Every social planner agrees that the only way to reach the majority of the illiterate popularization with development information in country as large as India in a quick and efficient way is via the mass media. This paper examines science and technology communication in India, The need for science literate population - Our current condition, Globalization of media - Transmitting global or local culture in India, Local requirement of knowledge and information, Global media for local use, Expectations across media, Action

required for media's role in getting science for all, Science literacy goals, Guidelines for reforms.

**Keywords:** science literacy, communication, science and technology communication, global media.

---

---

## How Media Helps in Communicating Science- A Review Paper

A. Arora

Address-DP-263, Near DAV School,  
Pitampura, Delhi, INDIA  
anshu1mali@yahoo.co.in

**Abstract.** Introduction-More and more science communication studies scholars are accepting popular media as a subject worthy of academic consideration.

Technology becomes a tool, supporting the learning process as learners seek new knowledge and understanding. The challenge here is to define the new approach to learning with sufficient clarity that it becomes a useful vision for future generations.

There are many modes of delivery for informal science education content, but for the purposes of this paper, we have focused on the following forms of media: television, radio/audio (including podcasts and streamed audio and video files via the Internet), film, and planetarium shows. School and universities are availing of these new educational channels, and there is also an increasing level of vocational training performed via the computer. The impact of media is vast on children and even on the adults. The intellectual curiosity of a child is satisfied by media literacy. Electronic media are playing an increasingly more important role in education and training.

Technology has improved so much today, that it is easy to teach in ways that are both interactive and communicative. Constructivism has come to stay and technology, and more specifically multimedia, has surely helped in its popularity.

Purpose

This paper focuses on one aspect of Science Learning through media, which are the

development, implementation, analysis and evaluation of a literature review done under a broader area of “Science and media”.

Design/methodology/approach

The paper discusses the following concerns

What is the nature and quality of media as a tool for learning science?

The defining characteristics of learning from media? How and in what way are they different across types of media? Are they different across target audiences?

To what extent have traditional communication theories formed the design and evaluation of media in science learning environments?

How can theories of learning be brought to bear on designing communication strategies for media ?

What are the methodological challenges in conducting studies on the impact of media on learning and what methodologies have been most effective?

The initial review covers topics within the areas of science and media, print media, electronic media and cyber media.

Findings

Benefits arising from the initial review exercise identified areas where media (all forms of media); engaging people in it and raise awareness or attract viewer’s involvement in the media, and also discussing issues and giving legitimacy to concerns raised informally by it.

Originality/value

Helps scholars in science communication to identify areas for development via the review process that would give directions for future research in this area. The purpose of this paper is to encourage research in order to expand the use of multimedia in the sciences, use of media and devising communication strategies for usage of media of different target groups.

**Keyword.** Science, media, learning, communication strategies.

---

---

## Reaching the Unreached Children – The Need of the Hour for Rural Schools in India

M.A.J. Rajan<sup>1</sup> and A. Thaddeus<sup>2</sup>

<sup>1</sup>Department of Physics, Arul Anandar  
College, Karumathur, INDIA

<sup>2</sup>Department of Zoology, Jayaraj  
Annapackiam College for Women,  
Periyakulam, INDIA

anjellojothi@rediffmail.com

**Abstract.** A survey was conducted on Under-Graduate students in science in one of the rural colleges in Tamil Nadu and in some city colleges in Madurai district of Tamil Nadu. The results reflected that high ranking students wish to pursue higher studies and careers in computer sciences and information technology. The high salary associated with huge perks has attracted young minds in this field, thus depriving the fortune for the growth of basic sciences. If this trend continues research in the basic sciences like Physics, Chemistry, Biology and Mathematics will suffer a major setback in India. We have already experiencing the slow down in the International Publications arena.

This survey motivated us to work for popularizing science by starting Science Clubs in villages in the Southern parts of Tamil Nadu, India. The work actually started as we got acquainted with the Vigyan Prasar, DST, Government of India in March 2009. We also found in general that rural cognition is often neglected in all fields and science education is not an exception. We have helped nearly four rural schools, one orphanage, and one evening tuition centre for rural boys and girls to start science clubs with the enthusiastic participation and support of our Under-Graduate Physics Major students.

In this paper we share our experiences with children from III to VIII standards and teachers in starting Science Clubs in rural schools with some activities using the Science Kits supplied by Vigyan Prasar by translating the contents in the regional language. We have also demonstrated some activities based on Earth Learning Idea published by Keele University, UK with their permission. These ideas will also be demonstrated by us during the conference. We wish many young teachers to join hands with VP

and popularize science and the achievements of science to the unreached rural children of Indian schools.

“If the future is in anyone’s hands it’s in the hands of our children”.

Prof. Harold Kroto

---

---

## Green Chemistry Experiments as Hands-On-Science Tools for Environmental and Green Chemistry Education

K.K. Nandi

Department of Chemistry Brahmananda  
Keshab Chandra College, 111/2, B. T. Road,  
Kolkata – 700 108, West Bengal, INDIA  
kknandi@yahoo.com

**Abstract.** Development of green chemistry, [i.e., design of chemical products and processes that reduce or eliminate the generation of hazardous substances], is an exciting and sustainable achievement in recent years. On the other hand environmental problems pose as severe threats to the modern civilizations. Green chemistry has an important role to play towards achieving a sustainable civilization through the proper training of future scientists/chemists by implementation of ‘Green Chemistry Education’ in chemistry curriculum. The concept of ‘learning by doing’ can be applied for effective learning of chemistry in particular and science in general by using green chemistry concepts, principles & experiments. Chemists in industry and academia are pursuing green chemistry experiments and developing new educational materials for Green Chemistry Education and environmental training. Green chemistry practices can provide pedagogical benefits and contents of greener curriculum [i.e., with the practical advantages of improved safety & reduced hazard], which are also essential for sustainable future. It is imperative to implement Green Chemistry Education and also to find model experiments as hands-on-tools to cope with the curriculum effectively. Participatory demonstration of simple green chemistry experiments showed great impact on learner with the advantages of stimulating them to find new/similar experiments to replace the existing hazardous one by them. Educators also need

appropriate tools/materials/methods to integrate the green chemistry effectively into their teaching and research programs. Many teachers of organic chemistry, including the present author, are trying to modify the organic chemistry laboratory curriculum with green chemistry experiments/processes.

This study reveals new educational materials and describes few redesigned green chemistry experiments/ strategies as useful hands-on-science tools for Green Chemistry Education. Hands-on-activity based on these green chemistry experiments are found to inspire & motivate the students/learner to cope with the green chemistry curriculum effectively and also to stimulate themselves to design similar/new experiments in future. So with green chemistry knowledge and more sustainable chemical practices students will realize that green chemistry can be used to solve rather than cause, environmental problems.

**Keywords:** green chemistry education, hands-on science, tools, organic chemistry experiments.

### 1. Introduction

The most important goal of sustainable development is to reduce the adverse consequences of the substances/chemicals/techniques that we use or generate. The role of chemistry in general and green chemistry in particular is very vital to ensure the use and generation of chemicals/materials & energy processes in context of sustainability. This in turn depends largely on the principles (12 – principles) & concepts of green chemistry<sup>1</sup>. The green chemistry is defined as the design, manufacture and applications of chemical products and processes that reduce or eliminate the use and generation of hazardous substances. Recent developments in the field are found as exiting and with enormous achievements<sup>2</sup>. On the other hand public concerned over global warming/ green house gases/ chemical accidents/ environmental pollutions are growing. And some of the environmental problems (e.g., DDT, Ozone depletion, Bhopal disaster, Love canal pollution etc.) pose severe threat to the modern civilizations. Now-a-days students are profoundly interested and want to understand how the human actions affect the sustainability

of our world. Specially, the chemistry students as they have few experiences at least in the miniature form to face the problem in their laboratory/ classrooms, they have unique scope & experiences to enter into the exciting and expanding field of green chemistry. Green chemistry concepts in collaboration with basic chemical education enhance the scope to cope with the challenges of environmental problems to achieve sustainability. The future sustainability<sup>3</sup> [meeting the needs of current generations without sacrificing the ability to meet the needs future generations] can be achieved properly by overcoming many hurdles. First, is to incorporate and integrate the green chemistry concepts and practices into the main stream chemistry curriculum. Second, is to implement the green chemistry education with effective bridging of relevant disciplines including the environmental education in high-secondary and tertiary levels of education. So the concepts of green chemistry must become an integral part of chemical education and research for achieving sustainable future<sup>4-6</sup>.

Green chemical practices are increasingly being implemented and new educational materials are also been developed as tools for green chemistry education. Effort and endeavour of educators, including the present author, to include and apply the green chemistry concepts and principles in chemistry classrooms and laboratories are found worthwhile for students (future chemists) to face the challenge of sustainability<sup>6-8</sup>. Many of the laboratory experiments are found to have harmful/toxic parameters. We can see the problems as miniature form of severe environmental problems. Effort to solve these problems can in tern provide necessary knowledge and model experiments for sustainable developments. So the scope of development of model green chemistry experiments in view of safer laboratory practices is enormous. And these model green chemistry experiments, modified with alternative eco-friendly chemicals/ materials, will definitely complements as hands-on-science tools to cope with the curriculum of green chemistry education.

## 2. Methodology

The concept of learning by doing is found effective during the development of model green

chemistry experiments through active participation of students. This module of green chemistry has been advanced through the following steps:

**Step-1:** Identification of existing hazardous experiment & systematic recognition of hazards/toxicity as a physical and chemical property that can be modified.

**Step-2:** Utilization of identified laboratory experiments for illustrating green chemistry concepts/principles by critical evaluation of chemical hazards and effects on human health & environment through total life cycle assessment.

**Step-3:** Development of alternative green chemistry experiment realizing the molecular basis of hazard/toxicity in view of safer laboratory practices and reducing hazards and wastes by using eco-friendly materials.

Systematic journey through above steps will improve the greenness of the experiment to an optimum level. Out of green chemistry principles [12 – principles] following concepts and measures actually guide us to modify and evaluate the greenness of chemical experiments:

**Measure-1:** Make less harmful process by the use of inexpensive & eco-friendly materials [catalysts/solvents/ reagents] as far as practicable.

**Measure-2:** Attain maximum atom economy [incorporation of maximum atoms of reactants into the product] with no or minimum wastes and by-products.

**Measure-3:** Prefer catalytic and/or recyclable processes as alternative to stoichiometric one.

**Measure-4:** Reduce energy requirement by performing reactions at ambient temperature and pressure without compromising the yield.

## 3. Green Chemistry Module on Friedel-Crafts Acylation of Organic Chemistry

In the present study we have identified and redesigned the Friedel-Crafts Acylation reaction of organic chemistry<sup>9</sup>. This method has chosen firstly, due to popularity of the reaction among both UG and PG students and secondly, due to the fact that most of the concepts/ principles of green chemistry can be discussed/applied using this method.

**Reaction:** Friedel-Crafts Acylation is generally employed for 'C—C' bond formation.

Acylation agent: acidchloride/anhydride.

Catalyst: Lewis acids catalysts.

Solvents: carcinogenic benzene derivatives.

Scope of developments of Friedel-Crafts acylation reaction: Critical analysis of Friedel-Crafts Acylation conditions reveals the following **disadvantages**;

- Catalysts:** Lewis acid catalysts,  $\text{AlCl}_3$ ,  $\text{BF}_3$ , etc. are hazardous and stoichiometric amounts are required and also lost during working up processes.
- Acyating agents:** Acid-chlorides are toxic and acid-anhydrides are less efficient. Both are associated with non-recovery of by-products.
- Solvents:** Benzene and its liquid derivatives (carcinogenic) are generally used.
- Methodology:** Huge amount of energy lost during heating and refluxing.

Application of green chemistry concepts/measures:

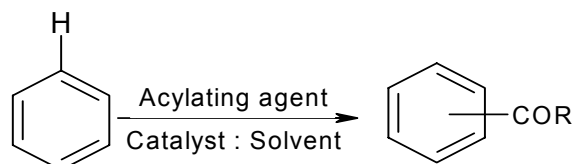
**Concept-1:** To make **less wasteful/harmful process**, use of hazardous Lewis acid catalysts,  $\text{AlCl}_3$ ,  $\text{BF}_3$  etc and also that of toxic acid-chlorides are to be avoided. Eco-friendly materials e.g. Reusable Catalysts [ $\text{ZSM-5}$ ;  $\text{Al}_2\text{O}_3$ ; and  $\text{M}(\text{OTf})_3$ ,  $\text{ZnO}$ , etc.] and nontoxic carboxylic acids as acylating agents are found to make the process green.

**Concept-2:** To attain **maximum atom economy** by-products are to be avoided or minimized. From the table-1, it is clear that use of carboxylic acids as acylating agents is best, since the loss in this case is water (18 m.u. only) and found as minimum.

Acylating agent:	R-CO-Cl	$(\text{RCO})_2\text{O}$	$\text{RCOOH}$
By-product molecule	HCl	$\text{RCOOH}$	$\text{H}_2\text{O}$
Mol. Wt. of lost Molecule	36.5	>60	18

Table-1

**Concept-3:** The process to be **Recyclable and with Catalytic pathway**. To avoid stoichiometric use of Lewis acid catalysts,  $\text{AlCl}_3$ ,  $\text{BF}_3$ , etc. which are lost during working up reusable catalysts/ eco-friendly materials e.g.  $\text{ZSM-5}$ ;  $\text{Al}_2\text{O}_3$ ; and  $\text{M}(\text{OTf})_3$ ,  $\text{ZnO}$ , etc. may be used. Require amount of Bismuth Triflate is 1% mole only.



**Concept-4: Energy minimization.** Instead of high temperature heating or reflux, we have to have green Friedel-Crafts Acylation at room temperature and/ or in microwave conditions. Both the above green methods of heating are available in Friedel-Crafts Acylation.

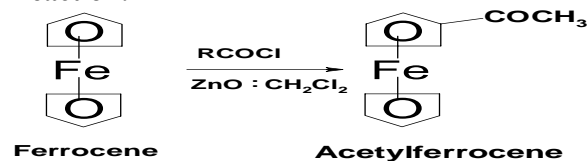
In fact gradual removal of all disadvantages and non-green features of Friedel-Crafts Acylation reactions are possible. Now some of the model green chemistry experiments are discussed which can be well performed by the undergraduate/postgraduate students in their normal laboratory class hours.

#### EXPERIMENT-1:

*Friedel-Crafts Acylation of ferrocene over eco-friendly ZnO at room temperature:*

**Green chemistry concepts:** Less hazardous, Recyclable Catalyst and Energy minimization.

**Reaction:**



**Procedure:**

In this approach<sup>10</sup> ferrocene was acylated with different acid-chlorides over eco-friendly  $\text{ZnO}$  catalyst at room temperature. The reaction completed in 15 minutes [monitored by TLC] and on normal work up acylferrocene was isolated characterized spectroscopically. The acylation of first ring deactivate the second thus only monoacylated product is obtained. The used  $\text{ZnO}$  was washed reused (2-3 times) without loss of efficiency.

**Green advantages:**

- Eco-friendly easily available ZnO as recyclable catalyst.
- Room temperature reaction and simple method minimize the energy input.
- Small reaction time and less harmful method.

**Non-green features:**

- Toxic acid-chlorides (RCOCl) are used as acylating agents.
- Chlorinated hydrocarbon, CH<sub>2</sub>Cl<sub>2</sub> used as solvent.

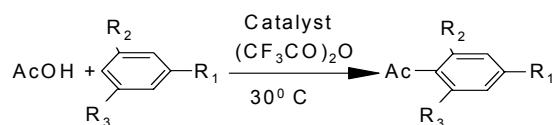
Students have been self motivated to overcome the problem of removing non-green features and tried to find more green experiments. Instructor should guide with necessary informations.

**EXPERIMENT-2:**

***Solventless Friedel-Crafts Acylation with Carboxylic acids at Room Temperature:***

**Green chemistry concepts:** Catalytic & Recyclable Pathway, Green Reagents, Atom economy and Energy Minimizations, etc.

**Reaction:**



**Catalysts:** Bi(OTf)<sub>3</sub> or Sc(OTf)<sub>3</sub> with TFAA ; R<sub>1</sub>, R<sub>2</sub>, R<sub>3</sub> = H / Me / OMe etc.

**Procedure:**

In this method<sup>11</sup> aromatic ketones are prepared in solventless condition at ambient temperature using recyclable catalysts [metal triflates] with trifluoroacetic anhydride [TFAA]. Both the aromatic and aliphatic carboxylic acids are used as successful green acylating agents. Required amount of catalyst were found 1% mole only. Here recycled catalyst specially, Bi(OTf)<sub>3</sub> was found to used without loss of activity<sup>11</sup>.

**Green advantages:**

- Atom economy of the reaction is higher due to loss of by-product is only water. The water is a small molecule (18) of eco-friendly/ non-polluting nature.
- Reaction follows actual catalytic pathways [1% mole] instead of stoichiometric amount in conventional method. Catalysts can be recycled.
- Use of green acylating agents [RCOOH] and no solvent make the process green.
- Room temperature reaction and simple method minimize the energy requirement.

Instructor should explain how the green principles are applied to Organic synthesis, specially, relating to above four measures discussed in the module.

**4. Conclusion**

This study reveals a new module of green chemistry on Friedel-Crafts Acylation Reaction of Organic Chemistry which has many practical and pedagogical benefits for the implementation of a greener curriculum. Re-designed two model experiments can serve as hands-on-science tools for teaching and research laboratory. These new educational materials also teach the relevant considerations for a chemical synthesis including costs, environmental impacts, and effects on personal and public health. Two model experiments of this module are also found to inspire & motivate the students/learners to cope with the prevention of pollution at source & to stimulate themselves to design similar /new experiments in future.

**5. References**

- Anastas, P. T., Warner, J. C., Green Chemistry: Theory and Practice; Oxford University Press; Oxford, 1998.
- Horvath, I. T., Anastas, P. T., *Chem. Rev.*, **107**, 2169, 2007.
- Parent, K., et al., Going Green [Integrating Green Chemistry into the Curriculum], ACS, 2004.

- [4] Collins, T. J., *J. Chem. Educ.*, **72**, 965-966, 1995.
- [5] Cann, M., *Green Chem.*, **3**, G23-G25, 2001.
- [6] [www.chemsoc.org/gcn/educate.htm](http://www.chemsoc.org/gcn/educate.htm) and [www.academic.scranton.edu](http://www.academic.scranton.edu)
- [7] Doxsee, K.M., et al., *Green Organic Chemistry, Strategies, Tools and Lab-Experiments*.
- [8] Sharma, R.K., et al., *Green Chemistry Experiments*, GCNC, New Delhi, Tucker Prakashan.
- [9] Olah, G. A., *Friedel-Crafts Chemistry*, Wiley, New York, 1973.
- [10] Nandi, K. K., *Proceedings of IUPAC – International Conference on Green Chemistry*, New Delhi, 2006.
- [11] Matsushita, Y., Sugamoto, K. & Matsui, T., *Tet. Lett.*, **45**, 4723, 2004.

---

---

## Creating Climate Change Awareness through Exposure Visit

I.A. Aram

Associate Professor, Science & Technology  
Communication Division, Department of  
Media Sciences, Anna University Chennai,  
Chennai, INDIA  
[arulram@yahoo.com](mailto:arulram@yahoo.com)

**Abstract.** India has over 7,500 km of coastline with nine states and four union territories along the coast. Its state of Orissa, being at the head of the Bay of Bengal, is often hit by cyclones. The frequency and intensity of cyclones have increased in the recent decades. The 1999 super cyclone that hit Orissa claimed about 30,000 lives and displaced one million. People opine that the sea has turned rough since the super cyclone and they attribute this to climate change.

The natural bio-shield of mangroves (which grows in estuaries) is on the decline – 56 percent of mangroves in Orissa have been lost in the last 25 years. Mangrove areas are encroached for prawn farming and other activities. Sea ingression continuously swallows land or leaves cultivable land unfit for cultivation because of salinity. Once the seawater enters land, the land

becomes uncultivable for three years. Of late, efforts are made to protect mangroves and develop other forms of bio-shields such as casuarinas which also serve as wind breakers. To protect the coasts from tidal activity, developing bio-shield and conserving sand dunes are options better than boulder walls. Climate change causes roughly 1 mm sea level rise a year, and in some places such as the Orissa coast probably more rise than that. The fact that coastal areas are more vulnerable to natural disasters means that communication needs to be customized for coastal disasters.

This paper is based on an exposure visit to Puri district of Orissa. The villagers have vivid memories of the super cyclone of 1999. Although the loss of human lives in Puri district in the super cyclone was minimal, most people along the coast lost their houses, lands, fields, livestock and their livelihood. Villages affected by the cyclone had to manage relief and rescue operations themselves without much external help. That means, they have developed stronger community bondage to face crisis situations. In the new millennium, civil society initiatives of developing women-managed self-help groups (SHGs) and environment education in schools have contributed a lot to climate change awareness in coastal areas. Besides, people from the villages going elsewhere to work and the mass media were responsible for creating awareness of climate change. Despite the West's greater share to blame as it leaves greater carbon footprints, people of coastal Orissa blame themselves for the fate. As one villager living close by the sea says, "We have destroyed the nature, the jungle, and polluted our environment. And we suffer due to sea level rise. But this is our village, our land. Where else can we go? Unless there is no other way we shall stay here." He says this despite the sea having swallowed up to 10 km of land in the last couple of decades along the coast. This study is based on observation and in-depth interviews on climate change awareness in the coastal villages of Orissa worst affected by climate change, as part of exposure visits.

---

---

## A Lifelong Learning Project for Science Teachers in Rural Region of Turkey

M. Erol and R. Sahingoz  
Bozok University, Faculty of Science and  
Arts, 66200, Yozgat, TURKEY  
mustafa.erol@bozok.edu.tr and  
recep.sahingoz@bozok.edu.tr

**Abstract.** The European Commission has integrated its various educational and training initiatives under a single umbrella, the Lifelong Learning Programme (LLP). As a part of LLP, Leonardo da Vinci (LdV) programme enables Vocational Education Training (VET) organisations to work with European partners, exchange best practices, increasing the expertise of their staff and respond to the teaching and learning needs of people. Modular Mobile Education: Science Experiments (MOBILIM) is a transfer of innovation project of LdV, funded with support from Centre for European Union Education and Youth Programmes. 11 institutions from 5 different European countries (Italy, United Kingdom, Portugal, Greece and Turkey) came together to make an international consortium for the project. The aim of this project is to reach out to the science teachers in rural region schools who have no laboratory facilities and to offer them the means of teaching science through laboratory experiments with mobile science laboratory (MSL) to do face-to-face training courses which focus on the recent experimental paradigms in the area of science teaching and to donate them with the relevant supporting pedagogical principles. The project has reached out to the 223 science teachers in Yozgat, a rural city, via a MSL to give experimental vocational education. The target group was categorized into 15 groups in 10 different towns. The education program was organized for 4 days for all groups. In the first day 'science is fun' type experiments have been demonstrated. In the other three days physics, chemistry and biology experiments have been done respectively. The main objectives of the vocational education was to prepare a network of teachers interested in laboratories and science teaching techniques, to provide medium for discussion to make it possible to exchange ideas and experiences, to give opportunity to the

teachers to obtain some new ideas for science fairs and to develop internet resources for the use of science teachers in rural regions. The vocational education was applied in three stages: (i). Doing the experiments in the MSL. (ii). Re-organization of the laboratory in the school of rural region by experts. (iii). To emphasize 'science is fun'. Positive feedbacks are obtained from the questionnaires for participants carried out during the vocational educations and also via web site of the project.

**Keywords:** llp, ldv, yozgat, science education, mobile science laboratory, vocational education, science teachers in rural areas.

---

---



## Make Your Own Physics Demonstrations!

Ching-Chi Chu, Tsung-Cean Tu and  
Hsiao-Ching Su

Department of Physics, National Central  
University No.300, Jhongda Rd., Jhongli  
City, Taoyuan County 32001, TAIWAN  
ccchu.ncu@gmail.com, tuchern@gmail.com,  
sunnygreta@gmail.com; <http://phy.tw/>

**Abstract.** The Department of Physics of National Central University (NCU) has been researching and developing more than a hundred of physics demonstrations in the past few years, which have been dedicated to undergraduate students • General Physics course. The Website of the laboratory has hit 270,000 mark and ranked number one on both Google and Yahoo Search (traditional Chinese version). The major users of these demonstration experiments are the freshmen enrolled in College General Physics. However, due to numerous requests from K-12 school teachers, we also developed some demonstration kits and helped teachers to assemble/ use them. The : demonstration-aided teaching ; benefits those school teachers in their classes. We propose three demonstration kits in this workshop, hand-held spectrometer, black body radiation illustrator, and racing balls kit. All of them are made of low-cost materials and designed to be easily assembled.

**Keywords:** physics, demonstrations, spectrometer, black body radiation, racing balls.

---

---

## Benchmarking and Testing Needs and Use: The Art and Science of Making Choices to Design IT Hardware Courses

I. Berezovska  
14 Glyboka St., Apt. 71, Lviv 79013,  
UKRAINE  
[iberezov@hotmail.com](mailto:iberezov@hotmail.com)

**Abstract.** Because many of the benchmarking and diagnostic/testing tools used by information technology (IT) professionals and educators now are accessible online, the authors conducted a research to provide insight to understanding the role and instructional potential of these tools in teaching IT hardware courses. Technology has radically changed the way educational institutions function in an academic environment and the services they provide. This paper discusses creating courses and developing instructional programs on information technology topics. The authors attempt to provide the principles of instructional design that can be applied to small workshops, to full-length courses, or to individual teaching modules. The principles are presented as they relate to teaching hardware in information technology, but in fact, they could be applied to other allied courses. Educators should consider the instructional value of benchmarking and diagnostic/testing tools when developing and offering new IT-related courses for their students, especially since necessary software, online help, tips and reference searchable databases are available at many web sites. However, there is a certain dangerous, because, as indicated in FOLDOC Free Online Dictionary of Computing, "in the computer industry, there are three kinds of lies: lies, damn lies, and benchmarks". Therefore the purpose of the paper is to provide a general description of the research study design that teachers can then use to interpret the relevance of benchmarking and diagnostic/testing tools. The authors discuss the reasons to integrate benchmarking and diagnostic/testing tools into IT hardware-related courses, the problems caused by the availability of too many tools, the approaches to skimming and then selecting these tools accordingly to the educational needs (e.g. how to select a proper tool which is relevant to a PC configuration and meets the goals of field

practice), the purposes and usefulness of different tool types (e.g., general-purpose toolkits versus device-specific applications), and the need for critically reviewing and updating the material. Representative examples are provided. While intended originally for university faculty, the described approach is relevant to any educator, researcher, practitioner, or student in the information technology.

**Keywords:** benchmark, diagnostic tool, testing, information technology, hardware, course development.

---

---

### A Novel Green Chemistry Practice in Testing Gases

I.G. Shibi

Department of Chemistry, Sree Narayana  
College, Chempazhanthy, Trivandrum,  
Kerala, INDIA  
shibiig@gmail.com

**Abstract.** Green chemistry is a chemical philosophy which encourages the design of apparatus, products and processes that reduce or eliminate the use of hazardous substances. Practicing waste minimization and pollution prevention in schools and colleges teach environmental responsibility. It encourages safety in the laboratory and save money. A major problem in inorganic qualitative analysis is to carry out identification tests for the gases produced in different experiments. The generation, collection, and testing of gases in teaching laboratories usually involves lot of practical difficulties owing to the inadequacy of suitable glass apparatus. The present methods involves the assembly of different glass apparatus like test tubes, glass tubes etc. which ultimately will not sufficient to carry out the required tests in a satisfactory manner. The gas generated during a reaction cannot be trapped and allowed to react with test reagent completely. Moreover the consumption of the reagents is more than that are strictly necessary which leads to the generation of excess gas, and the disposal of products and unconsumed reagents creates another problem. The present work reports the design of a novel glass

apparatus which can be easily used for the identification of gases like CO<sub>2</sub>, H<sub>2</sub>S, HCl, SO<sub>2</sub> and NH<sub>3</sub>. The tests performed by using the new glass apparatus, demonstrated its great utility and convenience in microscale chemistry laboratory. The chemicals to be used with this technique are in small quantities and much time can also be saved for the performance of the experiments. The apparatus can be safely handed, and can also be used in conditions such as shaking or heating.

---

---

### Popular Science Activities at National Central University, Taiwan

Ching-Chi Chu, Hsiao-Ching Su  
and Tsung-Cean Tu

Department of Physics, National Central  
University No.300, Jhongda Rd., Jhongli  
City, Taoyuan County 32001, TAIWAN  
ccchu.ncu@gmail.com, sunnygreta@gmail.com,  
tuchern@gmail.com, <http://phy.tw/>

**Abstract.** The Science Education Centre of National Central University, founded in April 2007, is dedicated to facilitate advancement in science learning and teaching in formal education system, and to enhance public scientific knowledge through informal educational activities. It has adopted types of media and approaches to promote science education to not only students from K-12 to college levels, but also the general public who shows interest and eagerness toward science learning. The current achievements of science popularization includes: 1) science weekly newspaper concerning cutting-edge scientific topics targeting the mass readers in Taiwan; 2) public open lectures featuring prestigious experts on various research fields; 3) Holiday Science Plaza involving everyday science phenomena and application for the public from the elderly to young; 4) science exploration activities for younger generation of foreign spouses in Taoyuan County of Taiwan; 5) training programs utilizing Demonstration-Aided Teaching for K-12 teachers and 6) website (<http://phy.tw/>) encompassing articles and supplementary learning materials regarding many sub-fields of science learning. By continuing the science activities catering to the needs of different

groups, the Centre aims to foster and stimulate public interests in science, to equip our audience with enhanced science cultivation, and hopefully to enrich their knowledge which may better their creativity in making use of science that improves their life. With this vision, the Centre endeavours to fulfil its duty and commitment to social service and education.

**Keywords:** science education, popular science, science learning and teaching.

---

---

### Access to Consumer Health Information: Changes under Influence of IT Progress

I. Berezovska and K. Buchinger  
Department of Computer Sciences, Ternopil  
State Technical University 56 Ruska St.,  
Ternopil 46001, UKRAINE  
Central/Eastern New York Lead Poisoning  
Prevention Resource Centre SUNY Upstate  
Medical University, Department of  
Pediatrics Room 5600, 750 E. Adams Street,  
Syracuse, NY 13210, USA  
iberezov@hotmail.com, mylibrary@earthlink.net

**Abstract.** Both positive and negative sides of using IT and the Internet in health care are well known and generally recognized. One can literally say that almost all patients and their relatives, i.e. health consumers, are interested in health information resources because they are getting more actively involved in the decision making process regarding optimum therapy. Healthy persons, however, are also much involved with consumer health resources because they want to maintain their good health status. In general, the healthy life style does not require extensive publicity any more. Thus, the interest in biomedical information is always motivated, and all people make many efforts to locate the data they need [1]. However, to be successful in searching biomedical information a health consumer should have relevant skills and should not lose common sense while using that information otherwise it is very easy to get feeling yourself like J, the main character from “Three Men in a Boat” by Jerome K. Jerome – “I remember going to the British Museum one day

to read up the treatment for some slight ailment of which I had a touch ...I plodded conscientiously through the twenty-six letters, and the only malady I could conclude I had not got was housemaid's knee”. Today such an ordinary health consumer has left from a library to the Internet and has become the most active user accordingly to reports published by Pew Internet & American Life Project (<http://www.pewinternet.org>). Since patients can concentrate on their own problems, finally they may become consumer-specialist [2]. A health consumer profile can be described with the numerical data from many surveys conducted by the Health on the Net (HON) (<http://www.hon.ch>). These surveys provide useful data to size up physicians' attitude to the Internet as a source of consumer health information as well. There is no need to explain that the dissemination of unsafe biomedical information is very dangerous. Unfortunately, most users who search for health information for their own are not competent searchers able to critically evaluate and refine the search results. This issue was thoroughly considered by the HON which developed the so-called HONcode (<http://www.hon.ch/HONcode/>). It allows compiling a list of evaluation criteria that every user can easily apply to a Web site to check the reliability and safety of the health information it provides. To conclude, let us do back to J whom we left sitting face-to-face with a medical reference book – “I had walked into that reading-room a happy, healthy man. I crawled out a decrepit wreck”. The same may happen with many Internet users if the access to vitally important health information is not properly mediated by biomedical information specialists.

**Keywords:** consumer health information, the internet, access, safety, evaluation, reliability, health consumer profile.

#### References

- [1] Brian McKinstry. Do patients wish to be involved in decision making in the consultation? *BMJ* 2000; 321: 867-871
- [2] Calabretta N. Consumer-driven, patient-centered health care in the age of electronic information. *Journal Med Libr Assoc* 2002 Jan; 90(1):32-7.

## Energy and CO<sub>2</sub> - A Common Challenge for Europe

J.F. Fernandes<sup>1</sup>, J.P. Santos<sup>2</sup>  
and M.F.M. Costa<sup>3</sup>

<sup>1</sup>Escola EB João de Meira, Guimarães,  
PORTUGAL

<sup>2</sup>Escola Secundária Martins Sarmiento,  
Guimarães, PORTUGAL

<sup>3</sup>Universidade do Minho, Departamento de  
Física 4710-057 Braga, PORTUGAL  
mfcosta@fisica.uminho.pt

**Abstract.** In this communication we will present a Comenius school cooperation project "Energy and CO<sub>2</sub>" - a common challenge for Europe". The aim of our project was to get 12 to 16 years' old pupils from various secondary schools in different countries to work together for a better future within the EU' Comenius framework. This project includes a cross curricular dimension since it will involve classes and teachers in many different subjects, such as physics, biology, information technology and English.

Each school will work about their own region and present and discuss their solutions for this major problem with the pupils of the other schools to get a Europe perspective on the subject. Pupils' work will all be reported in English enabling the exchange of information between participating schools.

Towards the end of each school year, several pupils from the different schools come together for discussing and exchanging of ideas and solutions from their research. Pupils will discuss the solutions found for other regions/countries and think on the possibility of use it in their own region.

We promoted new approaches in this research process with and extended use of the internet, computers, digital cameras and even building and using robotic models.

Saving resources and using alternative energies is the key to a positive view in the future!

---

---

## An Experience on: How to Disseminate Scientific Knowledge to the Community

M. Martinho<sup>1,2</sup>, S. Seixas<sup>2</sup>  
and R. Fonseca<sup>1</sup>

<sup>1</sup> Associação Portuguesa de Ciclídeos,  
Alameda da Guia, 219, 2750-371 Cascais,  
PORTUGAL

<sup>2</sup> Universidade Aberta, Rua Escola  
Politécnica, 147, 1269-001 Lisboa,  
PORTUGAL

macmartinho@gmail.com, sonia@univ-ab.pt,  
r.a.f@sapo.pt

**Abstract.** In Portugal, aquariophilia is a popular hobby but fish frequently die in home aquariums because of lack of knowledge. It is frequent, even in some shops, to see species of different environments and requirements together or predators and preys being put together.

So it is necessary to teach people in how to properly set up an aquarium, taking care of it, choosing the correct species to put together, the water chemistry, and so on.

There is much literature on the subject in the market, but in foreign languages and sometimes using a scientific language not understood by the common hobbyist.

So it was decided to put forward an action in the biggest animal fair in Portugal. In order to accomplish this, another Portuguese association in the hobby was contacted, as well as a university and we had the support of the fair organization. A workshop was set forth during the two afternoons of the weekend of the fair.

Normally the public would come to the fair to see different species and to buy some animals and related products. To attract people a stand was established in the middle of the exhibition area with chairs, a projector and sound equipment and was surrounded by several aquariums with different environments in a total of 72 m<sup>2</sup>. The public reaction was above our expectations, all chairs were occupied and there was public assisting standing up.

Because of the success of this workshop, included as an attraction event in the fair, the organization of the fair are interested in doing something similar this year and other local fairs

are inviting the association to promote other events.

---

---

## Science Communication - Present Scenario and Future Trends

A.K. Agarwal  
Central Building Research Institute (CSIR),  
Roorkee, INDIA  
atulcbri@rediffmail.com

**Abstract.** Science and Technology is considered a very important tool to eradicate hunger and poverty and offers opportunities for substantial increase in the standard of living of people. Science achievements contribute to our everyday life, improve social development and create fundamental conditions for innovations in industry and economy. It is important to promote new scientific inventions in a way that helps people who do not work in this specific area to understand the role and significance of science. In India there is a gap between society and economy on the one side and science on the other side. Potential animosity between society and scientific community is caused by lack of mutual understanding and distrust. Consequently, this negative trend prevents proper application of research and development to foster improvements in both society and economy. People in general usually do not understand the importance of science and are unaware of the fact that science can contribute to growth of their living standard. They therefore do not quite see the reason of investing major amounts of public investments in science. The existing barrier between society and the scientific circles in India is one of the main reasons why science is not considered to be one the priorities of public spendings. Our main goal should be to change general perception of the importance of science for society and economic development. This can be achieved by means of providing various projects in the area of science popularization and the related services for research institutions. Article 51 A (h) of Indian Constitution reads (citizen have a duty) “to develop the scientific temper, humanism and the spirit of inquiry and reform”. This article is of a subtle in nature and seems to need inputs from Govt., NGO’s and voluntary groups of educated or devoted citizens

(especially Scientists). Popularization of science comes to bridge a gap in communication channels between science and society. It should be listed as an Information Science (IS) subject in the syllabus of some working Groups. The objective of the popularization of science is to increase public understanding of science. Since the reader is not a scientist, a ‘translation’ has to be made, making science more accessible. Central Govt. & Institutes like NCSTC, NISSAT, NISCAIR, Science magazines, many newspapers are trying to popularize science. Supporting events such as National Science Day, Technology Day, Earth Day, and CSIR Foundation Day are organized for the general public by the R&D organizations and other science festivals contributes understanding of science in public. This paper intends to explain the efforts required in science popularization, suggest roles for information scientists in the promotion of science literacy and efforts taken by CBRI / CSIR in this direction.

**Keywords:** science, science communication, science journalism, society introduction.

Every society rests on certain general principles which serve as its foundation, ensuring it stability and strength. Amongst these are that was is bad, peace is good, terrorism needs combating and poverty must be wiped out etc. Over the past few years, another claim has been added to the list – scientific and technological progress is a virtue. This has not always been so – and may not always be so – but for the moment, few voice serious opposition to the claim. But, the changes science and technology have made, and continue to make, strike one and all in one or the other way. Science and its corollary, information, are certainly as old as humanity. Science is knowledge, and knowledge is not inborn, it is acquired and accumulated only if it is transmitted. Experiments must have been carried out and the accounts kept. However, the need to popularize science arose towards the end of seventeenth century, when the emergence of a quantitative, mathematical approach to knowledge of the physical world left behind the majority of readers. Science communication is nothing else than an endeavor to image scientific ideas in such a way that everyone (especially non-scientists) can grasp the fundamental concepts and have an idea of what science in

essence is. Indeed, no one really knows what 'Science' is, not even the scientists themselves. Philosophers trying to describe what the scientific method should be, found out (lot of time they took) that there is nothing like the 'one and only' scientific approach. The impossibility to give a distinct and unique definition follows. Nevertheless, the phenomenon 'Science' and its results do exist. Although nobody can tell exactly what 'science' is all about, everyone should have an idea anyway. The question at stake is whether this is possible and, if so, to what extent. Science communication or journalism is the key to the real treasure of the scientific knowledge, by virtue of which scientific knowledge and concepts could be carried to the common man. Thus the common man is benefited with the new advancements in science and technology and is able to fight against hunger, drought, diseases, and social evils, like superstitions, etc., with self-confidence, courage and faith. Being aware of this fact, science journalism in India has yet to come out of its present stage of infancy. The science communication in its real term had begun with publication of a scientific journal, Asiatic Researches, quarterly from the Asiatic Society, Calcutta in 1788. Thereafter, the science communication in India has evolved in many facets. Following this, there has been a continuing development in the formation of scientific institutions and publication of scientific literature. Subsequently, scientific publications also started appearing in Indian languages by the end of eighteenth century. The publication of ancient scientific literature and textbooks at mass scale started in the beginning of nineteenth century. In the beginning of the twentieth century, new trends emerged. Science congresses, scientific and industrial exhibitions, seminars, industrial and technological museums, public lectures, popular science magazines, etc. were few among the newer developments towards science communication. But the pace of these activities remained low and no significant effort was done to popularize science among the people and inculcate a scientific temper amongst them. The same pattern more or less continued till independence. Present Perspective After Independence, the Scientific Policy Resolution of March 4, 1958 has been a guiding factor for development of science and technology in the country. It was the first Prime Minister of India, Pt. Jawahar Lal Nehru, who gave an impetus to

scientific pursuits and development of scientific outlook. The independent India witnessed a rapid growth in the efforts of science communication. With a view to integrate, coordinate, catalyze and support the efforts of science communication and science popularization in the country, the Government of India established the National Council for Science and Technology Communication (NCSTC) in 1982 as an apex body, which puts more concerted efforts in this direction. A number of programs and activities have started in public and private sectors to spread scientific knowledge and scientific outlook among masses, especially in vernaculars, but science journalism in its real form could not evolve and remained an inner page affair for the media, with few exceptions. Nav Bharat Times, a leading Hindi daily, started a science column in the year 1948. Today, unfortunately, in most of the dailies, weeklies and monthlies, one cannot see much coverage of science and technology. It is desirable and imperative to introduce science columns in newspapers/ magazines. A few newspapers, however, cover science/ technology news and also have introduced regular science columns. But, in a country like ours, where not many people are exposed to the basic principles of science and technology, this, by itself, is not sufficient. Rarely, a science editor or a science reporter is associated with a newspaper or a magazine. It is desirable to have science correspondents with all newspapers. This would, in due course, help evolve a policy on editing and reporting of contemporary topics on science and technology in different modes of presentation in the media. The scientific writing in our country today is chiefly limited to describing various aspects of a particular topic, either in a descriptive manner or in praise of it. A large number of our science writers and scientific journals are from the public sector and hence it is difficult to expect them to be analytical or self-critical. Further most of the R&D in our country is being carried out in government (public funded) laboratories and there is hardly any means for the common people to know what scientists are doing. To bring public awareness in our country in the field of research, there is a need for investigative journalism in this field. Whatever is happening in this field, good or bad, proper or improper must be brought before the people, only then science journalism/communication in our country would

flourish in its complete form. Science journalism in India is nearly devoid of any investigative journalism. This form of journalism is attractive in its own way and retains readers' interest in the article to read further. Normally, a journalist publishes an article after a thorough investigation on political, social, or an economic issue. This aspect, however, is largely absent in the case of scientific topics. Perhaps, scientific issues are considered as being free of any human weaknesses, or not important enough to deserve investigative reporting. Science reporters could visit a scientific laboratory and interact with scientists in order to know the current scientific research and developmental work going on and bring it to the people. It is necessary to realize that investigative journalism does not imply investigation of any irregularity alone in a laboratory/ organization, but bringing to the people those useful technologies also still not known far and wide. Scientific literacy is necessary for the economic and healthy well being of the social fabric and every person, and for the exercise of participatory democracy. It also implies the ability to respond to the technical issues that pervade and influence our daily lives. It does not mean detailed knowledge of scientific principles, phenomena or technologies, however, it rather points out to the comprehension of what might be called the scientific approach, or the scientific way of conduct or the method of science. Science journalism keeps people aware about the latest in the field of research and development and helps them lead a life with better knowledge and understanding of newer advancements. The last two decades have been characterized by the rapid development of new scientific and technological advancements across a wide range of fields. Access to these advancements is distributed unevenly within the country. Even people in far-flung areas often lack access to not only traditional but also modern scientific knowledge. Effective localized science journalism can help enhance public awareness about science and technology confronting their day-to-day lives. Popularization becomes necessary when an area of knowledge moves into the hands of a limited number of specialists, and its contents become impenetrable to others as well as due to low literacy it becomes easier to blind people with science. The extraordinary development of science and technology during the last two

centuries has now made popularization a necessity to explain science to decision makers, but also by the moral obligation to give all the people of the earth a scientific background. It is a common place to say that science and technology have invaded both our homes, whether in the form of computers or television, stereo-systems and mobile or cordless phones and our professional lives, in the form of machines, electronic etc not to speak of our leisure time, health, travel, means of information and ultimately our thought processes. Science literacy is not only necessary among the educated, even among the illiterates. Our society today therefore demands an answer to almost everything. There are many ways in which science affects society. Well understood and taken for granted is the fact that without science living would be most difficult and full of hazards. But current developments in science have given rise to a set of problems, namely science-related social problems. Science-related social issues account for a large proportion of current world problems. It is now generally agreed that certain world issues are going to become acute in the foreseeable future, for example problems of energy, the environment, natural resources and the problem of the arms race. We are only just learning to formulate and discuss these problems, although the development of attitudes and the promotion of public awareness of their existence is one of the major challenges of our time. We cannot avoid these questions indefinitely. In this context, the popularization of science is of such importance that we need a new concept, a different approach for propagating ideas and influencing society than that used in the past. Although science popularization is necessary, a number of questions must nevertheless be raised and relevant answers given, e.g. what is science popularization? Who should be responsible for popularizing science and technology? What is the target audience? How should this popularization be done? What is the popularizer's role? \ It is difficult to give a precise definition of science popularization. Basic simple definition could be that it is the means by which scientific culture is spread, i.e. the means by which scientific knowledge, culture and thought are explained and made known. Science popularization is also a powerful factor in making people more aware of the importance

of science and technology in their daily lives and it would upgrade the living conditions of the people. For example, the information regarding the needs of immunization and vaccination, problems arising out of water pollution, environmental degradation. Simple health and hygiene practices, the importance of family planning are some of the basic requirements which are needed to be practiced by the large number of people. Knowledge gathered through science and technology in these areas and for proper agriculture, better productivity, conservation etc are to be provided to the rural masses and others. By popularizing science and technology, we will be able to change people's attitudes and made it easier for those in rural areas. Assimilation of science into culture has been a slow and difficult process. The ability to determine the significance of a new development is of great importance and it is what people really want to know about. Successful implementation of an innovation for the benefit of mankind depends not just on innovators, but also the public who can comprehend the impact of the new knowledge and use it. It is the availability of scientifically literate persons that has made the rapid progress of modern industry and commerce possible. Popular science needs a literary dimension. Science, literacy, however, is not the knowledge imparted by text books. Nor does science education or is it limited to those who opt to become engineers, scientists or doctors. It is a continuing process that helps to judge the pros and cons of the many promises made by politicians or of the actions of industries which might have long lasting detrimental effects on the society and the environment. Emerging Perspective In spite of a number of efforts for developing science journalism/communication in India, there are certain challenges, to be met. Such as number of capable science journalists/writers and popular science magazines is alarmingly low and hardly sufficient to cater to the large target audience. The science has still not succeeded in attracting the media to the extent that it could appear on the front page or become a lead story, like the politics, films or sports. Mass media has its commercial compulsions, which superimpose all the science communication efforts and leave a negative impact in the minds of the audiences. Instead of including scientific information, they prefer to generate more revenue by including non-

scientific information, etc. It is rather disappointing to note that leading science magazines have ceased their publication, like Science Today, Science Age, Bulletin of Sciences, Research and Industry, etc. and Indian editions of foreign science magazines, like Vigyan (Scientific American), World Scientist (La Recherche), etc. could not survive, however, recently Indian edition of Popular Science has been started from New Delhi. The science writing is still dry and boring, and interesting styles of writing, like fiction, poetry, satires, skits, discussions, etc. have not found adequate space and time in the media. Even most of the science writers could not contribute sufficiently such an interesting science material. Merely occasional appearance of something in the name of science fiction cannot serve the purpose. There has been emerging conflict between scientists and journalists, which is a great impediment towards the progress of science journalism in India. This can be resolved by way of organizing scientists-journalists meets on regular basis. There is a great shortage of properly trained science writers, journalists, communicators, illustrators in various parts of the world, though, a number of training programs are being conducted at various places. Therefore, more training programs are needed, which may preferably be conducted to give more opportunity to developing countries. Popular science writing in India is still shackled by complacency and over dependence on foreign sources. It is very difficult to get information from a scientific laboratory. The scientists in some organizations are not allowed to talk to the media about the research being carried out by them or in their laboratory. This requires a science media centre, to facilitate media persons to get research reports well in time. Following the industrial revolution in the western countries, the level of science coverage in mass media was exponentially increased. As such, India is passing through the same stage, in the present time. As the technology advances, the need of scientific information would also increase. Accordingly, the industrial India would soon witness the high time of science journalism, but the scientific community, media persons and public have to be vigilant enough to harness this opportunity. There is a need of debates in mass media on emerging issues of science and technology which are relevant to the people and



are of their immediate concern to enable them to take informed decisions to lead their life in a democratic society. Though, challenges are many, we could see some rays of hope, as India has been able to take initiatives in a number of newer programs in the area of science communication, such as, Vigyan Jatha, Children's Science Congress, and Scientific Explanation of So-called miracles, etc., which were not tried out elsewhere and can take lead in these innovative areas of science communication to better serve the mankind. Right to information is the basic right of the people. So they should be adequately informed about happenings in all directions. Article 51 A (h) of Indian Constitution reads (citizen have a duty) "to develop the scientific temper, humanism and the spirit of inquiry and reform". This article is of a subtle in nature and seems to need inputs from Govt., NGO's and voluntary groups of educated or devoted citizens (especially Scientists). This item under basic duties is of great importance to those popularizing science, since they too are trying to develop scientific temper, humanism and spirit of inquiry and reform (or modernization). In India where biased regionalism, jingoism, superstitions, etc are practiced, popularizing science and its material benefits are good ways of reform and progress. Popularization of science comes to bridge a gap in communication channels between science and society. It should be listed as an Information Science (IS) subject in the syllabus of some working Groups. The objective of the popularization of science is to increase public understanding of science. Since the reader is not a scientist, a 'translation' has to be made, making science more accessible. Central Govt. & Institutes like NCSTC, NISSAT, NISCAIR, Science magazines, many newspapers are trying to popularize science. Supporting events such as National Science Day, Technology Day, Earth Day, and Open days for the general public during CSIR Foundation Day on September 26 every year by a network of 37 laboratories of CSIR and other science festivals contributes understanding of science in public. Media definitely should play a major role in this respect. Newspapers, radio, television, and magazines should come forward and concentrate on important issues of science and print them regularly for the benefit of common man. The scientific developments within the nation and elsewhere should be made

known to scientists as well as non-scientists. Scientists have to come forward to solve societal problems. Communication of scientific and technological knowledge to the masses, therefore, would provide a major boost in our development process. If this can be structured, planned and propagated in the best possible manner it would serve a great deal to remove superstitions, ignorance and sufferings from our society. A further question that arises concerning the popularization of science is who should be responsible for it. There are journalists with scientific knowledge and scientists who write well, who are familiar with other media such as radio and television and they are well versed in techniques of film-making on science subjects. Similarly, science writers are also familiar with scientific concepts, methods, findings, theories and terminology. Science writing for non-scientific readers, listeners and viewers, is different from technical writing. Sometimes a journalist may be more effective in communication than a scientist provided that the accuracy of presentation is not compromise. Indeed, for effective communication, the use of simple and interesting language, setting the facts of science in an indigenous social, cultural and literary context would appear to be the right science and technology comes from science writers. They must serve the public by offering timely, informative and useful stories. This means that science journalists/writers will have to shoulder a greater responsibility to reach the goal. It is also disturbing to note that science writing is usually practiced in English. The question of language may be relatively simple in monolingual countries but in a multilingual country like India with as many as 15 official languages and hundreds of other local ones, it may be quite-difficult. It is also true that in an age when scientific knowledge is proliferating at a fast rate, the question of keeping up with scientific terminology within the limits of local languages becomes rather complex. Even then, we should try to communicate the masses in their own language and in a form through which they can easily get the message. In our country a large number of citizens still do not cross the boundary of the primary school. Many people are still illiterate. They understand their mother-tongue only and do not speak or write any other languages. So, it would be useless to communicate valuable information in English

only, leaving behind a vast majority who do not understand it. Therefore, the regional languages should be given enough respect for such kind of writing and communications.

### **Conclusion.**

It is time to recognize the shift in target population's interest, i.e. towards television, and science programs should be created in enough number through formats, which are most attractive to them. It may not be incorrect to say that docu-drama would be the most sought after format of science communication through television. When, India is passing through a crucial turning point of its development, we must take emerging trends into our stride and redraw our policies and plans, to be a nation of scientifically thinking and scientifically informed people. Hence, the efforts directed towards enhancing science coverage in mass media through effective and creative science journalism need to be given more priority. This is an issue, which scientists, media persons and the public have to take seriously and other side of the coin needs to be focused now. According to Indian philosophy science means Special knowledge. The Indian monks were of the opinions that the mystery of knowledge itself is science, and knowing science means to know the entire world, all the creatures present on the earth. About two thousands five hundred years ago, Gautam Buddha said "You should not believe anything since you have been told so or because that is traditional". Do not believe your teacher merely because he is honorable! You should stand with the principles in life which you not only have tested and analyzed but found absolutely favorable too

### **Acknowledgement**

The author is thankful to the Director, CBRI (CSIR) Roorkee for permitting to publish the Paper.

### **References.**

- [1] Patairiya Manoj, Science Journalism in India, first JourNet international conference on Professional Education for the Media, Newcastle, Australia, 16-20, February 2004.
  - [2] Satyaprakash, Bharatiya Vigyan Ke Karnadhar, 1967, Research Institute of Ancient Scientific Studies. New Delhi.
  - [3] Singh Ranbir, Are Most Science Writers Nearly Plagiarists, 1993, Pioneer, New Delhi.
  - [4] Vilanilam JV, Science Communication and Development, 1993, Sage Publications, New Delhi.
- 
-

## Nature Education in 22 Steps: A Model Proposal

N. Erentay<sup>1</sup> and M. Erdogan<sup>2</sup>

<sup>1</sup>Foundation School, Middle East Technical  
University (METU) 06531, Ankara,  
TURKEY

<sup>2</sup> Faculty of Education, Department of  
Educational Sciences, Akdeniz University,  
07058 Antalya, TURKEY  
nerentay@odtugvo.k12.tr,  
mmerdogan@akdenizedu.tr

**Abstract.** The purpose of this paper is to present data gathered from the implementations of the fieldwork within the context of ‘The Unique and Universal Project’ and provide guidance to teachers and parents, who plan to do field work with students. ‘Nature Education in 22 Steps’, by sharing a project management cycle, the process and steps followed, samples of observation sheets used by the students in the field, the shared data collecting tools used by the students, the reports based on students’ records and samples of their creative artwork, guides the instructor step by step through the entire process.

The model described in this paper is unique in Turkey. It has been trialed, tested and revised so that now it offers teachers, students and accompanying parents an experiential education experience that will lead students to be empowered in natural settings and to become future stewards of their Earth.

**Keywords:** project management cycle, nature education.

### A brief history of the book: nature education in 22 steps

‘Nature Education in 22 Steps’ is a guide to outdoor learning with elementary students. It is based on the practical experiences of students in the international project called ‘The Unique and Universal Project’. Students and teachers involved in this project have been engaged in adopting threatened wetland areas and studying them. Students have described habitats, observed endangered species, learned to analyze water quality through the use of their senses to learn about the natural world. They have also used the knowledge they gained to propose ways to

improve the threatened environments in order to support the endangered species.

As data is collected, the data is shared with students from other groups in the project – often in other countries. The project has been coordinated by the Middle East Technical University Foundation School since 2005 [see 1; 2; 3; 4].

‘Nature Education in 22 Steps’ is a book written for those who will undertake nature education with a group of people (i.e. students, teachers and parents). The book was constructed on four phases each of which is divided several steps. First phase, *Preparing*, includes six steps. Second phase, *Implementing*, includes seven steps. Third phase, *Reporting*, includes five steps. Last phase, *Sustaining*, includes four steps. These 22 steps are briefly described below for those who would like to utilize this guideline in their own setting.

### A. Preparing (6 Steps)

This phase includes six steps related to establishing a strong base for the project and preparing the structure of the project.

A.1. *Review of Literature and emphasizing the rationale:* In the first step of the project management cycle, comprehensive review of the literature on the selected topic should be undertaken so as to construct the framework and guideline for the project. During the review of literature, previous studies should be searched to find an area of understanding that needs to be filled so that the project can fill the gap in the selected area. In addition to review of literature, the rationale behind conducting such project should also be described.

A.2. *Calling for volunteer students and teachers, founding school working team:* The selection process for the students and teachers who would like to be involved in the project at the beginning of the educational term accelerates the productivity of the entire work throughout the year. The meetings devoted to the project are after school hours. The field trips to be conducted to the area occur on the weekends. The research to be done in the school library and on the internet and the controlled experiments to be conducted at the school laboratories require extra efforts, energy and time for students. Therefore they should be considered volunteer based activities.

A.3. *Establishing local and global connections, cooperation with NGOs:* Expertise, knowledge, experience, effort, volunteerism construct the whole only if they come together and unite to form it. The teachers involved in the project should cooperate with the NGOs and universities and get support from the research assistants on field work.

A national nature project is, at the same time, a global project for nature has no boundaries whatsoever. For example, an endangered plant in Turkey, a threatened wetland in Romania, and endangered animal in USA are global problems to be solved together. These problems and the data should be discussed internationally with all countries in the World.

A.4. *Forming project preparation team and conducting first meeting:* The volunteer members of the project team may vary depending upon the school climate. If the students are to be selected among the 4<sup>th</sup> and 5<sup>th</sup> grade, there should be homeroom teachers in the committee. It is also recommended that the committee has arts teachers as well. The guidance of arts teachers may initiate a procedure in which the students discover the close connection between the nature and themselves by using their own instincts and creativity. The students can compose a song, produce a poster, and organize a photography exhibition. These activities also motivate. They can prepare documentaries and share them with other partner schools via internet. There should be an IT teacher on the committee in such cases.

A.5. *Determining the target species and the target natural area:* The target subject of some nature projects can be constructed focused on biological diversity whereas others can be selected as studying a specific habitat. It is quite common that, news about an endangered plant on the national media, a documentary on television about Mediterranean Seals or a pool that is observed by the students at the schoolyard may instantly form the study subject of a nature project at a school. Sometimes different subjects that were studied in different years can be converted into a large scale nature project together. The students should take an active role in determining the study subject of the project.

A.6. *Preparing annual activity plan:* The annual activity plan should be constructed with the cooperation of the school administration, the volunteer teachers, the students and NGOs involved in the project.

A sample of tentative project calendar produced by the team students is presented in Appendix 1.

## **B. Implementing (7 Steps)**

This phase includes the seven steps that follow. Data collection instrument is developed in this step. If the study is designed as pre-test post-test experimental model, the data collection instrument(s) should be administered at the beginning and at the end of the field trips / field activities. The teacher / trainer can even develop field trip test(s) and apply it during the field trip. The participants are also certified at the end of this process.

B.1. *Developing data collection instruments:* In the first step of Implementation, the data collection instrument(s) should be initially developed for assessing participants' / target group's attainments at the beginning and the end of the project. While developing the instrument(s), the following sub-steps can be considered: 1) planning conceptual framework, 2) reviewing the existing literature, 3) analyzing the content and objectives for constructing table of specification, 4) establishing item pool, 5) preparing data collection instrument(s), 6) taking expert opinion, 7) conducting pilot testing, 8) assessing reliability and validity, and 9) getting the instrument prepared for the application.

The items and questions in the instrument(s) should be written according to the purpose of the study / project. For example, if you are involved in a project aiming to investigate students' perception and protection of biodiversity, you can design biodiversity knowledge test, attitude toward biodiversity scale, behavior questionnaire, interview schedule and such. Knowledge test, Attitude Questionnaire and Picture form developed for Unique and Universal project is given in Appendix 2, 3 and 4 as an example and further use of the readers.

B.2. *Administering the instruments (pre-test):* In order to assess students background, previous knowledge, attitude and behavior, and what they bring into the project, data collection instrument(s) should be administered to participants at the beginning of the project as a pre-test (that is, before starting the field trips). Pre-test results help the teachers/trainers understand student's current status and develop his/her activities accordingly.



**Picture 1** Students are filling the questionnaires before the field trip

**B.3. Getting prepared for the field trip:** In this step, the project schedule is introduced to the participants and other stakeholders. Furthermore, the participants can be guided to visit the experts (i.e. academicians, researchers, NGOs) for greater insight on the topic to be investigated during the project. The participants are also reminded how they are supposed to behave/act during the field trips. They are encouraged to have a bag including pencil, note-book, magnifier, boxes and so on.

Observation and experiment sheets can also be prepared in this step. Plant observation sheet, animal observation sheet, and soil observation sheet are some of the examples to be used during the trips. Prototype laboratory experiments (if necessary) can be conducted within the schools to enable the students to better understand the theoretical background of the experiments to be conducted during the field trips. Under the guidance of teachers, the students are encouraged to conduct, analyze and interpret the experiments.



**Picture 2** Students are working on prototype in the laboratory

Teachers should visit the site in advance to get well acquainted with the area and to be knowledgeable on the area.

Two samples of observation sheets are presented in Appendix 5 and 6.

**B.4. The actual field trip:** In this step, field trip is realized within selected and later searched area. One of the most important things during the field trip is to protect participants' health and safety. Before the field trip starts, safety and health protection guideline should be shared with the participants so that field trip can be done without any trouble.



**Picture 3** students are doing experiments with the water sample taken form the Lake during field trip

The experiments should be conducted by the participants under the guidance of teacher / trainer. This will help the students develop scientific process skills (i.e. observation, data collection, analyzing, interpreting, and reporting)

**B.5. Sharing field trip experiences within school community and with other schools:** The families, the immediate environment, the local units, the national and international society can be the targets for the message to be conveyed by the project.

**B.6. Administrating the instruments (post-test):** Once the field trip is completed and the participants return from the trip, it is time to administrate data collection instrument a second time to assess participants' gain. Another option is to administrate the instrument at the end of the projects or series of field trips. Knowledge change can be assessed in a short period, but the change in attitude and behavior can be observed over a long period. Successive administration (i.e. post-test and follow-up test) may sometimes be needed.

**B.7. Giving certificates to the participants:** The students are given a stewardship certificate

by the coordinator teacher at the end of each project year.

### C. Reporting (5 Steps)

This phase includes further five steps pertaining to reporting and presenting the findings and conclusions.

C.1. *Analyzing the data*: Having collected the data from the participants, it is time to analyze them to establish coherent themes and theory. The analyses should be undertaken based on the nature of the data collected. If the data is qualitative in nature (i.e. word), qualitative data analysis procedures (i.e. content analysis and descriptive analysis) should be utilized. On the other hand, if the data is quantitative in nature, statistical procedures (i.e. descriptive and inferential statistics) though the use of statistical software programs (i.e. SPSS) should be preferred. If the data set consists of both qualitative and quantitative data, mixed method can be used.

C.2. *Interpreting the findings*: In this step, the findings are discussed with regard to the similarity to and differences from the existing national and international literature. The previous findings are compared with the already existing ones. The reasons and the consequences of the findings are discussed in this part, as well.

C.3. *Discussing the limitations and findings*: Each study may include several limitations.



Picture 2 Students' drawing of selected endangered species

The readers of the report should be informed about these limitations and how these limitations can be dealt with. If the readers design similar project and/or research in the future, they can easily consider these limitations and overcome the problems during the preparation phase.

C.4. *Providing suggestions*: At the end of the project report, the implications of the findings for policy and practice, and also further research should be presented with details. This can help the stakeholders (i.e. teachers and researchers) use these implications in their contexts.

C.5. *Presenting the report*: Once the project calendar is completed, the report including all phases of the projects should be presented to required body (i.e. school principal and Ministry of National Education-MoNE). The project report should be designed by including the views and opinions of project team. The report, finally, is signed by project head and project team members.

### D. Sustaining (4 Steps)

This phase includes 4 sub-steps each for sharing the project outputs with other stakeholders and interested groups, and also for tracking the students' development and success.

D.1. *Presenting the outcomes in the national and international platform*: Once the project is completed, the results can be shared not only in national but also in international platforms with interested groups (i.e. teachers, representatives of NGOs, curriculum developers, and researchers). These platforms can be conferences, seminars, journals, magazines, newspapers and TV programs.

D.2. *Communicating with other schools*: The platforms involving schools, teachers and NGOs nationwide can also be used as a tool to disseminate project results to wide range of interested groups.

D.3. *Communicating with NGOs*: Communication with NGOs is also so important to reach wide range of interested groups. There may be research groups, governmental and community groups that are jointly working with these NGOs. Thus, being in touch with NGOs help the project manager/ team to reach variety of people who will show interest your study and findings.

D.4. *Establishing tracking system*: Preparing project report based on the results does not mean

that the project has totally finished / completed. The reflection of what the participants learned / attained through the project in the real life can only be traced through developing a tracking system.

## Conclusion

Knowledge is often forgotten unless it is put in practice. The application of knowledge when solving problems that the Earth encounters enables the knowledge to become useful. ‘*Nature Education in 22 Steps*’ is based on the application of knowledge. The model proposal offered in the guide book ‘*Nature Education in 22 Steps*’ provides a practical approach to experiential learning in nature with children.

It is the authors’ hope that this useful resource leads students, teachers and parents in developing new ways of gaining knowledge that can be obtained through studying in nature and, thus, developing new means of communication in which they can enhance their sense of connectedness to the natural settings.

## References

- [1] Erentay, N., & Erdoğan, M. (2006a). The “UNIQUE AND UNIVERSAL” Project: Exploring and Sharing Our Ecosystems through Scientific Processes. In M.F. Costa, and B.V. Dorrío (Eds.). *Science Education and Sustainable Development*. (pp.346-353). University of Minho, Braga, Portugal; The Hands on Science Network.
- [2] Erentay, N., & Erdoğan, M. (2006b). Initial Findings of “UNIQUE and UNIVERSAL” Project. In M.F. Costa, and B.V. Dorrío (Eds.). *Science Education and Sustainable Development*. (pp.390-398). University of Minho, Braga, Portugal; The Hands on Science Network.
- [3] Erdoğan, M., & Erentay, M. (2007). Children’s perceptions on endangered species and threatened environments: results from Unique and Universal Project. In M.F. Costa, B.V. Dorrío and R. Reis (Eds.), *Development, Diversity and Inclusion in Science Education*. (pp. 141-148). University of Azores, Ponta Delgada, Portugal: The Hands on Science Network.
- [4] Erdoğan, M., & Erentay, N. (2007). Children struggling for a sustainable future:

impressions from second year of Unique and Universal Project. In M.F. Costa, B.V. Dorrío and R. Reis (Eds.), *Development, Diversity and Inclusion in Science Education*. (pp. 148-157). University of Azores, Ponta Delgada, Portugal: The Hands on Science Network.

[5]

Appendix 1  
A SAMPLE of TENTATIVE PROJECT CALENDAR

Country and Approximate date	Activity	Subject area and subject-endangered species
TURKEY	PROJECT	
	Getting to know each other	
October – November	<ul style="list-style-type: none"> <li>• Forming small groups of three or four students depending on the number of participant schools.</li> <li>• Discussing general topics such as respective schools, homes, likes, dislikes</li> <li>• Starting research on the subject area</li> <li>• Documenting the data (what kind, how many, location)</li> <li>• Introducing Turkish to partners</li> </ul>	Mogan Lake & Centaurea Tehlutecheffii
December	<ul style="list-style-type: none"> <li>• Doing research about the Mogan Lake</li> <li>• Visiting, if possible, local environmental groups / people</li> <li>• Having a meeting with a visitor from Nature Society to be informed about the area</li> <li>• Organizing a field trip to the area and observing the area</li> <li>• Taking photos and making notes are an important part of this field trip</li> <li>• Reporting findings to partner schools.</li> <li>• In the meantime, studying partners’ languages</li> </ul>	
January – February	<ul style="list-style-type: none"> <li>• Creating graphs, videos and other visual aids and sharing with partner schools</li> <li>• Forming portfolio together</li> <li>• Analyzing the data</li> <li>• Studying partner schools’ languages</li> </ul>	
March	<ul style="list-style-type: none"> <li>• Preparing presentations that will be held on the same day in each country</li> </ul> <p>(Our possible date is 27<sup>th</sup> of March in our Cultural Centre)</p> <ul style="list-style-type: none"> <li>• Preparing posters representing species with slogan in each language.</li> <li>• Forming a website</li> <li>• Studying partner schools’ languages</li> </ul>	
April	<ul style="list-style-type: none"> <li>• Visiting, if possible, the local authorities in Mogan</li> <li>• Making use of MITU Radio to increase awareness and knowledge of local and global environmental concerns</li> <li>• Organizing 2<sup>nd</sup> field trip to the area and sharing the findings with their partners</li> <li>• Forming a website</li> <li>• Studying partner schools’ languages</li> </ul>	
May	<ul style="list-style-type: none"> <li>• Organizing a fair around Mogan Lake with the collaboration of local authorities, Nature Society and the public</li> <li>• Exhibiting all the work done by all partner schools</li> </ul>	
June	<ul style="list-style-type: none"> <li>• Students and teachers will have discussions for the proceeding year topic with the partner schools</li> </ul>	

Appendix 2

ATTITUDE TOWARD ENDANGERED SPECIES  
 AND THREATENED ENVIRONMENT  
 QUESTIONNAIRE

	I totally agree	I agree	I disagree	I totally disagree
(1) I think that the endangered plants and animals need to be protected.				
Why:.....				
(2) I think that the pesticides should be used only under the control of an agricultural engineer.				
Why:.....				
(3) When endangered animals are hunted, it makes me sad.				
Why:.....				
(4) I want to join a project for protecting endangered species and threatened natural areas.				
Why:.....				
(5) I think that unplanned industry, population growth, and urbanization do not have negative impacts on endangered species.				
Why:.....				
(6) When people do nothing to protect endangered species and threatened natural areas it makes me unhappy.				
Why:.....				
(7) I think that natural resources need to be used carefully and cautiously.				
Why:.....				
(8) Joining a project aimed at protecting endangered species and finding ways to do so makes me happy.				
Why:.....				
(9) I approve when people change natural areas to build a new building, park area or business offices based upon their needs.				
Why:.....				
(10) I think that each individual needs to do something to protect endangered species.				
Why:.....				
(11) I think that I can do something to help protect endangered species and threatened natural areas.				
Why:.....				
(12) When people irresponsibly pollute threatened natural areas, it makes me angry.				
Why:.....				
(13) Thinking of solutions for preserving endangered species and threatened natural areas makes me happy.				
Why:.....				

Appendix 3

KNOWLEDGE TEST

Name:.....  
 Gender: Female ( ) male ( )  
 Your class/grade:.....  
 Your age:.....  
 Education level of your mother and father:

	Mother	Father
Not literate	( )	( )
Primary school	( )	( )
Secondary school	( )	( )
High school	( )	( )
University	( )	( )
Master or Doctorate (after university) ( )	( )	( )

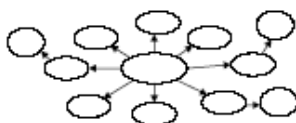
Example: The following figure includes the concepts related to plants.



- (1) A. When somebody says *endangered species*, what words come to your mind? Please put these words in circles in the figure below. (Please carefully examine which shows the concepts related to plants. This example might give you information about what you are expected to do in this question)  
 B. Show and identify the relationship among these words that you have stated. If you want to add new words that you think are related to other words, you are permitted to add new circles to the figure. For showing the relationship among the words, use arrows.



- (2) A. When somebody says *Monarch butterfly*, what words come to your mind? Please put these words in the figure below. (Please carefully examine the example given in box above. It shows the concepts related to plants. This example might give you information about what you are expected to do in this question)  
 B. Show and identify the relationship among these words that you have stated. If you want to add new words that you think that they are related to other words, you are permitted to add new circles to the figure. For showing the relationship among the words, use arrows.



- (3) In the World and in Turkey, some plant and animal species are endangered, as you know.  
 A. In your opinion, what are the main reasons these species are endangered?

B. Among these reasons, what is the most important one(s)?

- (4) In the World and in the USA, some natural areas are threatened, as you know.  
 A. In your opinion, what are the main reasons these natural areas threatened?

B. Among these reasons, what is the most important one(s)?

- (5) There are some projects and studies that have been carried out to protect endangered species and threatened natural areas.  
 A. In the World, how effective do you think these protection studies are? If not effective, please indicate the reasons.

B. In Turkey, what do you think about the effectiveness of these protection studies? If not effective, please indicate the reasons.

- (6) In addition to Monarch butterfly, what other endangered species (animal and/or plant) do you know? Please write their names and their main characteristics, and identify why these species are endangered.

- (7) Please indicate how much of your information about endangered species and threatened natural areas have been obtained from the following sources. Please use (X) to mark the response that is most appropriate to you.

	I have got very much information	I have got a little information	I have not got any information at all
a. My Family	( )	( )	( )
b. My Friends	( )	( )	( )
c. My School	( )	( )	( )
d. Television	( )	( )	( )
e. Internet	( )	( )	( )
f. Newspapers and Magazines	( )	( )	( )
g. Books	( )	( )	( )
h. Non-Governmental Organizations	( )	( )	( )
i. Project that I have participated (Project name(s):.....)	( )	( )	( )
j. Other (.....) Please indicate	( )	( )	( )

- (8) Which of the following procedures for helping protect endangered species and threatened natural areas would be influential? Please use (X) to mark the response that is most appropriate to you.

	Very much influential	A little influential	No influential at all	Not clear
a. Giving fine	( )	( )	( )	( )
b. Putting new laws	( )	( )	( )	( )
c. Prohibiting people to enter these regions/areas	( )	( )	( )	( )
d. Giving speeches by politicians	( )	( )	( )	( )
e. Creating special areas for the plants and animals located in these threatened areas	( )	( )	( )	( )
f. Preparing a program in television and radio (documentaries, speech, etc)	( )	( )	( )	( )
g. Stating news and articles in newspapers and magazines	( )	( )	( )	( )
h. Hanging posters out in the places everybody can see	( )	( )	( )	( )
i. Sharing the projects done and projects' results with the other students and teachers in the school	( )	( )	( )	( )
j. Holding conferences and seminars	( )	( )	( )	( )
k. Putting much more information about these topics in the textbooks	( )	( )	( )	( )
l. Warning people who are misbehaving in these areas	( )	( )	( )	( )

- (9) In relation to endangered species and threatened natural areas, and the ways of helping protect them,

	Sufficient	Insufficient	Not clear
a. Do you think that the subjects taught in the <u>classroom</u> are sufficient? Why? What are your suggestions?	( )	( )	( )
b. Do you think that the <u>classroom activities</u> done through the course are sufficient? Why? What are your suggestions?	( )	( )	( )
c. Do you think that the <u>course textbooks</u> used for the course are sufficient? Why? What are your suggestions?	( )	( )	( )

- (10) Up to now, what actions have you engaged in and/or what actions do you plan to engage in to help protect endangered species and threatened natural areas? Please write about the actions that you have done and plan to do.

(11) Additional comments:.....

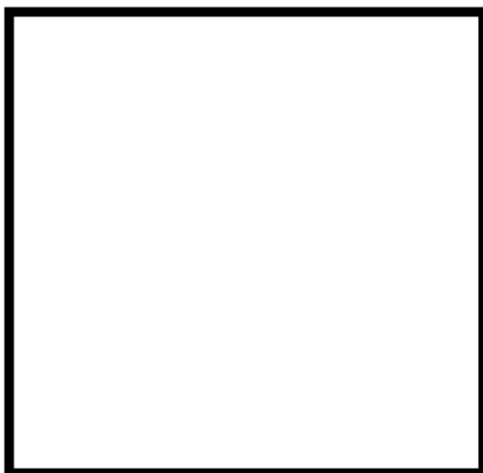


Appendix 4

FIGURE FORM

Picture of Endangered Species You Studied (i.e. Yasneröföör Plant);

Please draw a picture of Yasneröföör Plant ( *Cornusur Tchlthachelll* ) you are studying in this project, below provided area. At the end of the picture, write the main characteristics of this endangered species.



Main characteristics of Yasneröföör Plant;

Appendix 5 SOIL OBSERVATION SHEET		
NAME of the SCHOOL :	NAME of the TEACHER:	NAME of the STUDENT:
STATION :	OBSERVATION DATE :	OBSERVATION HOUR :
QUESTIONS		
SOIL CHARACTERISTICS	SOIL TYPES	
The depth : _____ cm	Garden soil	Wetland soil
The number of the soil layers		
Colour		
Smell		
Texture ( fine, gritty )		
Does it stain your fingers?		
Degree of wetness ( wet, damp, dry)		
Presence of organisms ( leaves, roots)		
Presence of living organisms ( insects, earth worms )		
Depth of plant roots		
The main difference between the samples of soils		
Conclusions		

Appendix 6

VEGETATION DATA SHEET										
NAME of the SCHOOL :		NAME of the TEACHER:		NAME of the STUDENT:						
WETLAND AREA :		OBSERVATION DATE :		OBSERVATION HOUR :						
QUESTIONS										
	STATION 1					STATION 2				
	plant types	number of plants	average height	other physical features	sketch profile	plant types	number of plants	average height	other physical features	sketch profile
THE VEGETATIVE DIFFERENCES BETWEEN STATIONS :										

## Faithful Secure Cloud Strategy

D. Joshi and P. Pandya  
Veer Narmad South Gujarat University,  
Udhana Magdalla Road, Surat,  
Gujarat, INDIA  
dhaval\_joshi81@yahoo.com,  
payalpandya\_mscit@yahoo.com

**Abstract.** Many organizations, which are growing and having new advancements, want their atomization on early bases and also with very low cost foundation. For these, organization attracted towards cloud computing – a new way of less expensive services based foundation. Using cloud computing, clients of cloud computing don't need to purchase infrastructure and expensive software(s). By using simple PCs and having proper Internet connections one can use cloud computing services provided by special providers (e.g. Google – Google Apps, Amazon – Web Services, Microsoft – Azure, Facebook and many more). But it is not every time be the best for the solutions, because it is having lot of issues related to security. Sometimes more critical or disaster issues with customer data and processes occur. Without knowing about the issues, one should not jump to use the cloud computing services. In this paper, I specified the issues related to cloud computing and a strategy for faithful secure cloud which can help to customer and provider (who take services of other provider) to put faith on the cloud computing and cloud provider.

**Keywords:** cloud computing, services, security, quality standards, security standards, security audits.

### Introduction

Cloud computing is a model in support of “everything-as-a-service” (XaaS). The flavours of cloud computing are Infrastructure as a Service (IaaS), Software as a Service (SaaS), Data as a Service (DaaS), Platform as a Service (PaaS), Network as a Service (NaaS) and Identity and Policy Management as a Service (IPaaS) in [1] [7]. One can acquire any or all kind of services to fulfill the requirement of the organization. Microsoft, IBM, Amazon, Google, Adobe - everyone is rushing to come up with a

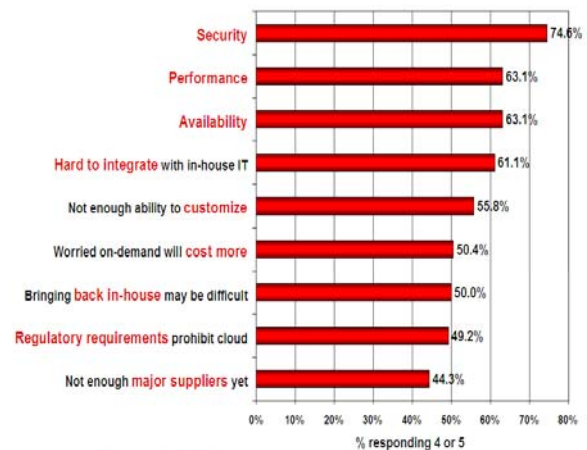
comprehensive “Cloud Computing” services to tempt the business. Cloud computing provides complete infrastructure to store and execute customer data and processes to deal with those data. The customer doesn't need to know how the data stores and which server is responding for the work and also about the infrastructure which is provided by the service provider. It is completely like pay for what you use. It may also happen that the provider may also take services from other provider(s).

Now days, the demand of clouds are more because of the following reasons in [2]:

- A low cost alternative to access technology
- Optimum utilization and dispersion of cost
- Greater independence and remote access
- Greater independence and remote access

Many organizations are moving towards the cloud computing. As a result, clouds are widely used and spread in the world. Thus, lot of issues are coming to use and implement the cloud. The maximum issues are because of Security. Fig. 1 shows the actual scenario in the real world.

Q: Rate the challenges/issues ascribed to the 'cloud'/on-demand model  
(1=not significant, 5=very significant)



Source: IDC Enterprise Panel, August 2008 n=244

Fig. 1. Issues ascribed to the 'cloud'/on-demand model in [3].

### Security Issues

#### A. Provider Security failure

The provider of the cloud service(s) is having full control on servers, network and complete infrastructure. Customers' data and processes are

running on it. Fig.2. shows the structure of customer and service provider system. So the customer has to put trust on provider's security. But if the provider's security is broken then the customer data and processes are not secure. The failure of security will lead to the violation of CIA (Confidentiality, Integrity and Availability) principles. Providers are also putting lot of efforts to secure their cloud.

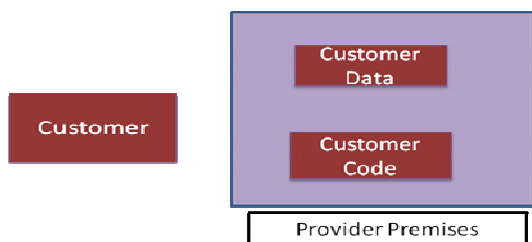


Fig. 2 Cloud computing sample structure

#### B. Attacks by Other Customers

Many providers on Cloud are providing all kind of resource service(s). So they use outsourced resource service(s) from other cloud service provider. But due to outsourcing activity the security attacks are possible. Sometimes directly or indirectly sharing of resources with untrusted parties takes place. And due to this, attacks on CPU processes and scheduling, network resources and storage areas are possible. The customer data and applications may be used by other customers.

#### C. Availability and Reliability Issues

If the provider is having all the resources in cloud, very less problems of availability and reliability will occur. But if the provider is relay for resource(s) on other provider(s) as shown in Fig. 3, the cloud availability will be less because of more transactions and communications takes places. Also the complexity increases in communication. The chance of failure also increases as complexity increases. More shared resources across cloud may invite attacks on it.

#### D. Legal and Regulatory Issues

The laws and regulations for any kind of activity also depend on locations. This also creates issues of preventing cloud computing. All the providers may not meet to certification requirements required for business. Geographical end users' privacy may not fulfilled by providers. Also when new locations come in picture then new

laws and regulations need to be observed and it may require more changes in provider criteria of work.

E. *Provider- Customer interaction Security issue.* The security systems may be applied by the customers separately which is not linked with provider's security. In between customer and provider communication security is also a big problem. Information can also be tracked in between.

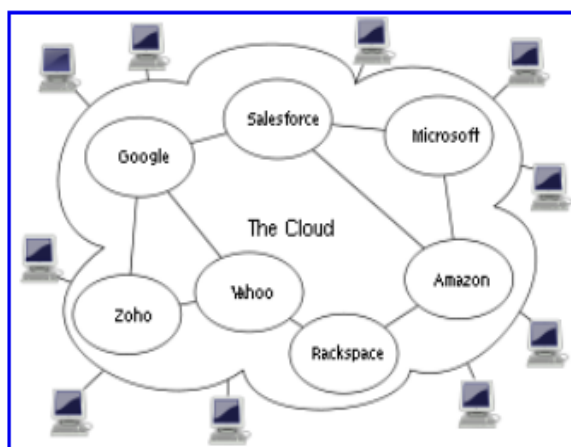


Fig. 3 Cloud of Cloud provider in [5]

### Example of Cloud Computing Security Issues

There are lot more cloud service providers available for the customers. Providers serve the customer to fulfill their needs of using cloud with security. Big organizations like Google, Amazon, FaceBook, are already in the market to provide such kind of services. Still the security is the big issues with them also.

A hacker has reportedly obtained and distributed more than 300 confidential documents pertaining to Twitter's business affairs. The documents were reportedly stored on Google Apps in [4].

The hacker apparently accessed documents with potentially sensitive information about Twitter employees, company finances, partner agreements, and other topics, and forwarded the documents to media outlets such as TechCrunch, which reported on the data breach before few days back.

Such kinds of giants in cloud are also facing problems of security. There are various security policies and security concepts are available and used to make the cloud secure.

## Security Policy and Concepts used in Cloud

There are various security policies and concepts are available and used for cloud to make it secure and also make it standardise up to cloud level. Those are narrated as follows:

### A. Information Security Standards

The International Standard Organization (ISO) has created information security standards which are used for information security in clouds as well by services providers.

As shown in the fig. 4, The ISO standards are having the CIA model and a series of ISO/IEC 27000 standard for information security. These standards are used for clouds also.



Fig. 4 CIA model in ISO Standards in [8]

### B. Secure Inter-Cloud Transaction using VPN

Using the VPN concept, the clouds are connected with each other. So the communication between the clouds will be secure.

As shown in the fig. 5, the Cloud: 1 and Cloud: 2 are connected using VPN. Both the clouds are secure internally. This concept is known as VPN-Cubed.

### C. MANAGED SECURITY SERVICES (MSS) for Outsource

Managed security services (MSS) is a systematic approach to managing an organization's security needs. The services may be conducted in house

or outsourced to a service provider that oversees other companies' network and information system security. Functions of a managed security service include round-the-clock monitoring and management of intrusion detection systems and firewalls, overseeing patch management and upgrades, performing security assessments and security audits, and responding to emergencies. There are products available from a number of vendors to help organize and guide the procedures involved. This diverts the burden of performing the chores manually, which can be considerable, away from administrators in [9].

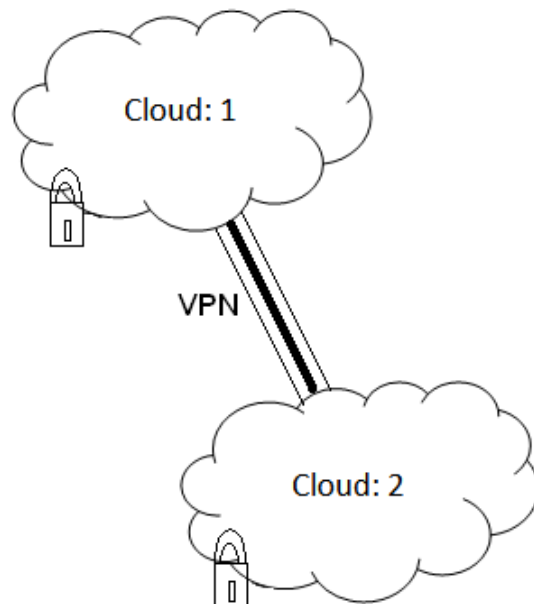


Fig. 5 Inter-Cloud Security using VPN

## Proposed Faithfull Secure Cloud Strategy

As such security policies and concepts are available and some of them are already implemented and some are in implementations. Still the security problems are coming, hance it is difficult to put faith on providers' security with the cloud. The following strategic enhancement will help to put faith on the cloud providers and will help customer to be free form the security concern with the application of cloud.

### A. Prepare standards for all kind of services

The standards need to prepare for all kind of services, which forces provider to implement on the cloud to give good service with security. All the services provided by a provider are secure

internally then the integration of the services will require the actual set of security concern.

*B. Need proper agreements with service providers*

The customer needs to prepare the agreements with the service provider about the service subscription along with the security of the cloud for data and process. So that, the customer will have faith on the cloud service provider.

If the service provider takes the service(s) from other provider then also the proper agreements along with security should be prepared. These collaborative cloud service agreements will improve the faith on the service providers.

*C. Cloud activity Monitoring and Logging*

The cloud activity should be monitored and the log of the cloud activity should be created. The assessment of the cloud security can be done based on it.

*D. Regular security audits*

Provider need to go through audits of security in regular interval. The audit reports will provide the details of the security breaks in the specified interval and what level of severity the attack had. It also provides the subsequent affects of the attack and with the previous audits comparison with other measures can be derived and specified in the audit report.

*E. Audit Report Discloser with Customer*

Audit reports need to put on display, so all customers can view it. With this report customer can come to know about the security of the provider's cloud. With the audit rank the customer can think to deal with the cloud provider for new or renewal of the subscription.

*F. Improve Privacy of Customer*

The privacy of the customer needs to improve with certain policies, which gives more freedom to the customer to work on their data and process, so that the customer can have more faith with the cloud.

## Conclusion

Usage of the Faithful Secure Cloud Strategy will help the customers and providers (who ask for services from other providers) to make the

selection of the proper secure cloud service and also in future if the security issues with the provider then to change the provider for cloud services. By applying such strategy the cloud computing demand may increase in future because of the faithful security provided by the service provider. The customers will not have confusion with the cloud security given by the service provider.

## References

- [1] Luis M. Vaquero et al., "A Break in the Clouds: Toward a Cloud Definition", ACM SIGCOMM Computer Communication Review, Volume 39, Issue 1 (January 2009)
- [2] Vikas Gupta, "Benefits of Cloud Computing – More to web for less", [www.webnewswire.com](http://www.webnewswire.com), May 2009.
- [3] Bill Whyman, Cloud Computing, Information Security and Privacy Advisory Board, International Strategy & Investment, [csrc.nist.gov](http://csrc.nist.gov)
- [4] Jon Brodtkin, "Theft of Twitter documents from Google Apps raises cloud security concerns", [www.infoworld.com](http://www.infoworld.com)
- [5] Wikipedia, "Cloud Computing", [en.wikipedia.org](http://en.wikipedia.org)
- [6] Gartner, "Gartner Says Cloud Computing Will Be As Influential As E-business". [www.gartner.com](http://www.gartner.com).
- [7] Chappell and David, "A Short Introduction to Cloud Platforms", David Chappell & Associates.
- [8] Booz, Allen and Hamilton, "Cloud Computing Security Standards – Evolving from the Classic Data Center Baseline", [www.boozallen.com](http://www.boozallen.com)
- [9] Managed Security Services, <http://searchmidmarketsecurity.techtarget.com>

## Methodology Used to Supervise the Theses of Bachelor in Biology (Educators of Children): from Traditional Distance Education to e- Learning

S. Seixas

Universidade Aberta, Rua Escola  
Politécnica, 147, 1269-001 Lisboa,  
PORTUGAL  
sonia@univ-ab.pt

**Abstract.** In this work was analysed the results of supervise of 35 thesis during 4 years with different methodology. In first year (academic year 2005/2006) was used traditional distance learning, mail, telephone and e-mail. On second year was used a mix of traditional distance learning (same of last year) and also used of a Web platform with some documents and important information. In third year, was tried to use e-learning methodology but it only revealed to be possible with 50 % of the students. During the fourth year was used an e-learning methodology, but in a session, in the beginning of the year, was made a presentation to explain the students how to use it and its advantages. In this last year, all communication with students was made by forums in a page created in Moodle Platform. The results reveal that the students did not feel comfortable with e-learning model in first months. But after some months the students messages in forums increased significantly. These forums were moderated by the teacher. In forums all students could read the doubts of the colleagues and the answer of the teacher. The failure detected was the almost total absence of messages in the forums for information exchange among students. To the teacher's e-learning methodology needs very attention, being necessary going to the Moodle page several times a week, but avoids the explanation of same thing several times. To students e-learning methodology makes students feel more accompanied, as inquiries of last year reveal.

---

---

## Astronomy in the Service of Mankind

S.R. Verma

Aketa Avenue, Rajpur Canal Road, Body  
Guard South, Dehradun, INDIA  
srvastro@rediffmail.com

**Abstract.** Astronomy is one area which has fascinated mankind from the beginning of history. The earliest man must have been the primitive astronomer. The striking spectacles presented to him by the varied appearances of a sky covered with thousands of twinkling and non-twinkling objects of different degree of brightness and daily changing phases of the moon must have raised strange feeling and curiosity to know about these celestial objects. Frequently asked question is how Astronomy is concerned with distant celestial objects, stars and galaxies and why should it be relevant to us on earth. Following are historical examples of how Astronomy helped human societies and cultures- a. Calendars b. Seasons and agriculture c. Religious Rites d. Navigations United Nations has declared the year 2009 as the 'International Year of Astronomy'. Four hundred years ago Galileo watched sky for the first time through his own telescope and revealed many secrets of nature. In the same year Kepler discovered three laws of the planet motion. These Kepler law gave basis of intuition of Newton's law of gravitation. The studies of planetary motions by astronomers had long term benefits which we enjoy today. Astronomical observations of comets, the discovery of new planets and studies of stellar structure established confidence in the law of gravitation in 18th century. In second half of the 20th century space technology was launched and built upon the foundations of the law of gravitation. None of the benefits of space technology would be available today if we did not have a law of gravitation. Astronomy added to the basic knowledge of controlled nuclear fission was developed. The another example of astronomy leading the way with new discoveries in science such as thermo-nuclear energy which will benefit mankind and solve its energy problem if the energy can be generated in a controlled fashion as in the star. Besides, space technology will one day bring sun's energy to the

Earth to satisfy human hunger for more and more energy.

---

---

## Tapping our Green Gold - Seed Oils: An Insight

S. Ahmad, D. Akram, F. Zafar  
and E. Sharmin  
Materials Research Lab., Dept. of  
Chemistry, Jamia Millia Islamia, New Delhi,  
INDIA  
deewanakram@gmail.com;  
deewanakram@rediffmail.com

**Abstract.** Several environmental and ecological problems have cropped up in the recent past due to increased consumption of petrobased chemicals and polymers in areas including lubricants, fuels, coatings and paints. The utilization of renewable resources such as starch, cellulose, proteins, cashewnut shell liquids, seed oils plays an important role to overcome such problems. Among these biobased feedstocks, seed oils are the most versatile, domestically abundant candidates abode to several functionalities viz., active methylenes, double bonds, epoxies, hydroxyls, esters, capable of host of derivatization reactions. Such oil derivatives can efficiently play substitutes to several petro-based polymers and chemicals. Fortunately, India is blessed with several varieties of oil-seed bearing trees in abundance, yielding both edible and non-edible oils. Only a meagre portion (approximately 7%) of these oils is utilized while the rest still remains as national waste. Tapping our green gold- seed oils, may prove cost effective, non-toxic, biodegradable and eco-friendly step towards substitution as raw material to fossil fuel derived polymers and chemicals finding plethora of applications. The Indian government has envisaged the cultivation of oil seed bearing trees on wastelands by farmers and encourages the biological and engineering applications of biobased feedstocks by academia and industry. The approach would cut off the heavy import duties; it will be instrumental in creating employment opportunities especially in rural areas and will also bring our academic and industrial research at par to international standards. In the present work, we have made an effort to discuss the role of seed oils in the field

of coatings and paints, with special emphasis on some state-of-the-art modifications in this area.

---

---

## Uses of Drama as a Learning Strategy

R. Pinner  
Derby University, UK  
richard.pinner@btopenworld.com

**Abstract.** In the UK there has been a fundamental change of government policy towards teaching fact-based subjects, with a new impulse to free up the curriculum for more imaginative and cross-curriculum teaching – allowing 20% of teaching time to be at the discretion of the individual teacher. The Government minister responsible, Professor Hepple, has given the example of how this might be interpreted for Science, through the subject of Climate in Crisis and the issue of sustainable growth, as this clearly connects with other subjects, such as Geography, History, Physics, Economics, Ecology and current affairs. So, at both school level and across all ages, the nature of this challenge is fourfold, for us to find ways for science to become: a) more appealing and interesting; b) more relevant to students' lives, connecting with the wider curriculum; c) more involving, participatory d) and more playful. The Workshop Taking a key controversy behind the objective facts (for example, how the advancement of genetic science has thrown up the issue of Designer Babies and the possibility of parents choosing the sex and characteristics for their children) we would then engage the group in the educational issues and learning criteria involved in planning a session for students across the learning spectrum. Furthermore, the session would explore/ discuss a range of drama techniques that could be exploited, including: 1) roleplay – by taking a historical or significant contemporary figure in the scientific sphere, demonstrating that this does not involve 'acting' skills on the part of the trainer so much as the representation of the arguments and points-of-view of this figure. 2) Hot-seating – this is an extension of role-play, this is also a skill that can be exercised by the students as well as the trainer within the context of the learning situation. 3) simulation – this involves the structuring of a more concerted

project, for example for a whole year group over an extended period. This could entail more detailed engagement and research across the curriculum (eg. graphics and displays, History, and Geography etc.). The workshop would engage the participants practically, whilst the lecturer would also illustrate the techniques employed. Delegates will be provided with a simple hard-copy of information and techniques used within the workshop.

---

---

## Popularising E-Governance for Development

J.K. Sarmah

Department of Political Science, Gauhati University, Guwahati, Assam, INDIA  
jayanta1947@gmail.com

**Abstract.** This paper is a brief introduction to the concept and process of e-governance (Electronic Governance) for which innovativeness in the approach and methodologies are significantly required. E-governance is the application of Information Technology to the processes of Government functioning to bring about simple, moral, accountable, responsive and transparent governance. E-Governance' is a network of governmental or non-governmental organizations or a one stop portal that changes the system of delivery of public services and increases the inter connections between the people and government. This process would be successful only if science and technology is popularized. Necessarily it must be popularized among the students, who are the future of nation.

India is a agricultural country. So far the agricultural sector is concern, e-governance refers to the use of ICTs in delivering governance products and services which are of use to farmers or those working in the agrarian sector, including livestock breeders and herders, milk dairy workers, agriculture extensions, agricultural traders, and NGOs working in the agriculture sector. At the same time, there are a range of governance products and services that are useful for the agrarian community, which lead towards enhancing crop productivity, efficient cattle farm management, providing for

national and household level food security, and conservation of bio diversity

Hence, there is a need to take a holistic view towards the entire e-Governance initiative across the State. To ensure successful application of e-Governance, Government of India has setup an institutional mechanism for formulation of Standards through collaborative efforts of stakeholders like Department of Information Technology (DIT), National Informatics Centre (NIC), Standardization Testing and Quality Certification (STQC), other Government departments, Academia, Technology Experts, Domain Experts, Industry, BIS, NGOs etc. Therefore, the paper tries to examine all significant efforts to popularize the process of e-governance among every sections of the society i.e. farmers, students, administrators, corporate and what not.

---

---

## Innovative Approaches for Diffusion of Farm Technologies at Grassroots Level

J. Saxena

Directorate of Information & Publication of Agriculture, ICAR, Krishi Anusandhan Bhawan-I, Pusa Campus, New Delhi, INDIA  
jgdsaxena@gmail.com

**Abstract.** In the time of global food crisis, the sustained food and nutritional security of the India's large and growing population is a daunting challenge before the nation. Depleting natural resources, rapid change in global climate, decreasing soil fertility and progressive change in land use patterns are further aggravating the problem. A country wide network of research institutions working under the aegis of the Indian Council of Agricultural Research (ICAR) has developed promising technological interventions for augmenting agricultural productions. However, the quality delivery of improved technologies to farmers, the end-users, is not keeping pace with the fast changing knowledge-intensive era. Several innovative approaches are being taken up to assess, validate, refine and demonstrate technologies related to agriculture, livestock, fisheries and other allied sectors under a unique National Agricultural Innovation Project (NAIP) being implemented by ICAR



with credit assistance from the World Bank. Besides, ICAR has developed an effective and comprehensive outreach mechanism for technological empowerment of farmers at ground level. Front-line demonstrations, training at farmers' fields and knowledge sharing through well-equipped Agricultural Technology Information Centres (ATIC) across the country have made significant impact in technology adoption by farmers. Study visits of farmers to the research institutions have facilitated wide exposure to the latest agricultural technologies. Watershed development programme is another innovative project where the holistic development of the area is taken up in participatory mode through diffusion of appropriate and site-specific technologies. Farmers have scripted a huge number of success stories in different regions by adopting improved and innovative technologies. The paper will discuss the innovative approaches that motivated and inspired the farmers to adopt agricultural technologies at field level. The constraints experienced during delivery of technology and suggestions for refinement of approach will also be deliberated.

---

---

### Enhancing Students' Attitude toward Science through Hands-on Instruction in Physics

Chung-Chih Chen, Chin-Hsueh Rd,  
Ta-Liao Hsiang and Kaohsiung Hsien  
Fooyin University, TAIWAN  
sc121@mail.fy.edu.tw

**Abstract.** The sharp drop in the interest of students for sciences has been reported in many countries. This decline in science teaching demands to provide students with a closer proximity to science through simple experiments. Constructivist learning theory suggests that students learning science best when they are actively engaged in doing science or performing activities that allow them to think like scientists. It is generally believed that when students do something by themselves they can understand much better than merely listening to explanation by the teacher. Furthermore, touching and manipulating material and objects can lead to a deeper understanding than that obtained from

vision. Hands-on experiment can be served as an active-learning strategy to engage students who dislike science. This study investigated the use of hands-on activity program as a means of improving students' attitude towards science. Methods and Sample. The subjects involved in this study were undergraduate non-science majors who attended a general education course about science. Each lesson in this course started with hands-on activities in ordinary classroom and then science concepts and explanation about the phenomenon were elicited afterwards. Interactive group were arranged to promote cooperative learning. In this study, an instrument was developed to measure the students attitude toward science at the beginning and end of the semester. Qualitative data were also collected from the classroom observation, the weekly worksheets, casual interviews, and an open questionnaire administered at the end of the semester. Results and conclusion Indicative responses from the students were very positive. Most students showed that the hands-on activities helped them to understand what they had only memorized. They agreed that the hands-on activities had a bearing in real life and the knowledge acquired would help in their own life situation. Furthermore, they felt that learning science was enjoyable and not so difficult.

---

---

### Communicating Science through VRCs in Tamil Nadu and Puducherry

D. Jayaprakash  
Department of Media Sciences, Anna University  
Chennai, Chennai – 600 025, Tamil Nadu,  
INDIA

**Abstract.** Communication of information about science and technology is essential for social and economic development. The media is often assumed as an efficient and effective means of disseminating information about various fields including science. Science communication is the key to the scientific knowledge, by virtue of which scientific knowledge and concepts can be carried to the common people. Thus, the common people are benefited with the new advancements in science and technology, and are able to fight hunger, drought, disease, and social evils such as superstitions, with self-confidence,

courage and faith. Science communicators usually communicate to non-scientific audience. Communicating science to the public comprises diverse approaches such as public talks, debates, exhibitions, publications, science theatre and television documentaries. Often, these activities form a part of a wider campaign to engage people in science. In recent years, the volumes of scientific information and news have grown rapidly, but the coverage in the media has not grown that exponentially. There is a need to analyze the coverage given to science news / information in Indian media with special emphasis on community media. Now that radio has got revival, it has gained speed of conveying information which no other medium has. The news/information on community media has a style and pattern of its own which is quite different from a report in the press. Community media can put across 'hot' news to create awareness, though awareness to action calls for an integrated approach to development. Of late, people are particularly interested in health and environment, and this has been reflected through increased coverage. The scope for specializing in environment communication and health communication is increasing. The community media of diverse nature – be it VKCS, VRCs, All India Radio, campus community radio, NGO community radio, and educational radio such as Gyan Vani makes efforts in imparting and understanding scientific temper. The paper looks into various possibilities of communicating science effectively through VRCs, particularly in terms of updating the people with the latest in science and technology. While, community media concentrates on broadcasting phone-in programmes, talk-shows, drama, discussions, symposiums, and debates on subjects of social interest, health, developmental activities and civic consciousness. The paper discusses the various modes of communication by the use of community media.

---

---

## **Robotics as a Tool to Increase the Motivation Levels in Problematic Students**

C.R. Ribeiro<sup>1</sup>, C. Machado<sup>1</sup>, M.F.M. Costa<sup>2</sup> and C. Pereira-Coutinho<sup>3</sup>

<sup>1</sup>Agrupamento Gonçalo Sampaio – Póvoa de Lanhoso, PORTUGAL

<sup>2</sup>Departamento de Física, PORTUGAL

<sup>3</sup>Instituto de Educação e Psicologia  
Campus de Gualtar – Universidade do Minho – Braga, PORTUGAL  
celiarosaribeiro@gmail.com,  
caelgoma@hotmail.com,  
mfcosta@fisica.uminho.pt,  
ccoutinho@iep.uminho.pt

### **Motivation**

The study described in this work was done by students of the Training and Education Courses (CEFs) in Informatics Operators of EB 2,3 Gonçalo Sampaio in Póvoa de Lanhoso during the academic year 2008/09. The study was conducted with two classes, with a total of 23 students. These students are aged between 15 and 18 years and the majority are males with only 4 girls. These students were not very motivated to attend school successfully, since they were students that had difficulties and failed one or more years. The CEFs were created to allow these students to finish their academic studies, in a less constrained pedagogical environment, that provided access to professional studies.

### **Objectives**

Given the special situation of these students, the main aim of the project was to study if the introduction of Robotics as a new tool would provide an increased in the level of motivation. Also, since those students are involved in a technological course, the Robotics activities would provide a valuable tool in Technological Education and an added factor in preventing the drop-off numbers. The teachers of the CEFs believed that this was a very interesting idea, but were afraid that the students would lose interest very rapidly, as it has happened before with other activities.

## Description

The study involved two teachers of the school and also the researcher. It was made possible through the provision of 2 hours per week, within the classes of students. Initially, students were involved in a period of approximately 1 month, learning the basics of robotics, particularly in the construction and programming of robots. They built their robots with the help of some available manuals. In each class, three Lego Mindstorms kits were available, so it was necessary to form groups. The students solved a series of exercises of increasing complexity, requiring both the construction of various types of robots as well as an extensive number of programming tasks.

After this continuous period of work, a set of students was selected to participate in the RoboParty, a robotics event in Guimarães, where about 100 teams competed for 3 days building their own robots (with a pre-designed kit by the organization). When it was time to select the students, it was difficult to choose who would attend. Everyone wanted to participate in the event, but we could only take two teams of three students. Given some difficulties in getting the parents' permissions, in the end, only 5 students went.

On the first day of the event, we had access to the kit and a little training to learn to weld. We went to the table and spent the whole day and part of the night welding our kits. This was a painful activity, since it was difficult to see where you had to weld which required very accurate movements. The students managed to perform this step with great efficiency. Afterwards, the students began on programming in Basic, a language new to almost everyone, except for one of the teachers. We all strive to learn this language so that we could program a few steps in our robots. We decided to dress the robots as two dancers typical of the Minho region. One robot was "Manel", the other was "Mary" and we entered the dancing competition, also selecting a typical dance from Minho. More than eighty teams entered the contest, so we were caught by surprise when they announced the first prize for dance and called the name of our team.

In the end of the school year, the students showed their robots to the community. Also, they participated in the National Robotics Festival (4<sup>th</sup> place in the dance competition) and were invited

by two schools (Amares and Santa Maria da Feira) to show their work.

## Discussion and conclusions

Since the beginning of our study, and to our surprise, the students were all interested and motivated at work. However, there were some that followed this trend, especially some of the girls that did not enjoy the activity that much. In future studies some care needs to be taken to try to integrate these students.

In the end, we believe this was a very positive experiment in pedagogical terms. In fact, the students were very proud of their endeavours and most of them kept their motivation levels high during the whole study. Some of the students that, before the project, were in risk of dropping out have revealed an interest in following their studies in a technological theme, after this period.

It is undeniable that Robotics makes an excellent tool for the learning of programming concepts and many other engineering and technology related subjects. Also, it provides an innovative, active and constructivist learning environment, promoting project-based learning. It is, therefore, a valuable tool in all levels of learning and with an added value in the context of technology students.

---

---

---

## Miraculous Demonstrations of Pedagogical Value to Introduce Concepts in Chemistry

S.B. Ghoderao<sup>1</sup> and R.D. Kankariya<sup>2</sup>

<sup>1</sup>Dept. of Chemistry, RNC Arts, JDB  
Commerce & NSC Science College, Nashik  
Road, 422101, Maharashtra, INDIA

<sup>2</sup>Principal, BJS College, Wagholi, Pune,  
Maharashtra, INDIA

sudesh\_4441@rediffmail.com,  
rdkankariya@rediffmail.com

**Abstract.** The demonstrations are used to introduce the concepts in chemistry, develop interest in student about chemical sciences. These can be done safely with prior training and knowledge. In present study 'live' demonstrations and booklet about it, is used at undergraduate level as an educational tool. The feedback of students through pre and post questionnaire indicates that demonstrations are effective in developing interest in chemistry in student.

The null hypothesis (H<sub>0</sub>) stands rejected for the overall effect of the treatment as the p value is 0.006

**Keywords:** chemistry education, miraculous demonstrations.

### 1. Introduction

The research work originates from educational reforms responding to the requirements of the socioeconomic renovation in the state of Maharashtra and India. The need of higher educated people in many scientific and economic areas requires higher education to change its mechanism and contents. In this context, university and college education must improve the traditional frameworks for teaching and studying. Besides supplying scientific and technical manpower to society, higher education is also designed to meet the needs of people in scientific and cultural education. To fulfil these requirements for the improvement of society, the educational system requires some reforms. Its objectives and contents should be scrutinized, especially in science education. There is a need

to develop a science curriculum and programs of study that reflects the true nature of the scientific enterprise, and particularly the interrelations of science, technology and society.

### 2. Background of the Problem

The curriculum of science courses were altered keeping in mind the advancement in science and needs of society. However teaching methods were not considered as a factor in educational reform. This raised some questions; why were teaching methods neglected as meaningful tactics in improving education? What models of teaching would be appropriate for bringing about the new objectives and goals for science education?

This study explores a teaching and learning method designed to improve the basic chemistry teaching in the colleges of University of Pune. It focuses on the effects on student attitudes of using the miraculous demonstrations integrated with lecture to teach a chemistry course.

Hoping the introduction of the miraculous demonstrations in the course, the researcher investigated that the miraculous demonstrations influenced interest of student in the chemistry subject. The students' attitudes were of concern in this study because the researcher believes that if students are interested in the subject, they can master it.

### 3. Objectives of Research

- to create useful literature in the form of a booklet describing scientific knowledge of so called miracles.
- to use scientific knowledge of miracles for developing interest in chemistry in students.
- to evaluate the effectiveness of the booklet in eradication of superstitions associated with miracles.

### 4. Hypothesis of study

1. Null Hypothesis (H<sub>0</sub>): The literature created in the form of a booklet and demonstrations of 'miracles' will not develop interest in student about chemical sciences and not eradicate superstitions associated with it.

2. Alternative Hypothesis (H<sub>1</sub>): The literature created in the form of a booklet and demonstrations of 'miracles' will develop

interest in student about chemical sciences and eradicate superstitions associated with it.

## 5. Methodology Adopted

The study is conducted for the students studying chemistry as one of the subject in S.Y.B.Sc class. The pre test is conducted in which the responses were given by the students. Then 'live' miraculous demonstrations were performed and feedback for effectiveness of it is taken in the form of intervening questionnaire. Then thorough discussion on the chemistry background of the miraculous demonstrations and superstitions associated is conducted with the help of the booklet prepared by the researcher as an educational tool. Then the feedback for effectiveness of booklet is taken in the form of post questionnaire.

## 6. Design and Administration of Questionnaire

The questionnaire developed was on attitudinal and other affective aspects of students. These aspects are not subject to change quickly. They were given enough time to complete the questionnaire at all the times.

## 7. Processing and Analysis of Data

The data, after collection is processed in accordance with the outline laid down for the purpose of the study

(Abbreviations used: SA- Strongly Agree, A- Agree, NI- No idea, DA- Disagree, SDA- Strongly disagree)

SA %		A %		NI %		DA %		SDA %		NR %	
B	A	B	A	B	A	B	A	B	A	B	A
40.	53.	49.	43.	6.	0.	2.	2.	1.	0.		
22	75	42	10	89	57	29	29	14	57		

**Table 1 Comparison of Miraculous demonstrations motivate to learn chemistry (Before-After)**

SA %		A %		NI %		DA %		SDA %		NR %	
B	A	B	A	B	A	B	A	B	A	B	A
40.	47.	45.	45.	8.	1.	4.	4.	1.	1.		
22	12	97	97	04	14	02	59	72	14		

**Table 2 Comparison of Miraculous demonstrations are exciting and interesting (Before-After)**

SA %		A %		NI %		DA %		SDA %		NR %	
B	A	B	A	B	A	B	A	B	A	B	A
52.	52.	37.	42.	4.	1.	3.	3.	1.			1.
87	02	93	19	02	72	44	44	72			14

**Table 3 Comparison of Miraculous demonstrations keep my interest during lecture/session (Before-After)**

SA %		A %		NI %		DA %		SDA %		NR %	
B	A	B	A	B	A	B	A	B	A	B	A
2.	2.	6.	5.	13.	11.	33	39.	43.	41.		
29	87	89	74	21	49	.9	08	71	04		

**Table 4 Comparison of Miraculous demonstrations performed in classroom are wastage of time (Before-After)**

SA %		A %		NI %		DA %		SDA %		NR %	
B	A	B	A	B	A	B	A	B	A	B	A
45	47.	41.	44.	8.	5.	1.	2.	1.		1.	0.
.4	12	37	82	62	17	72	29	72	0	14	57

**Table 5 Comparison of Miraculous demonstrations increase interest of student in chemistry (Before-After)**

SA %		A %		NI %		DA %		SDA %		NR %	
B	A	B	A	B	A	B	A	B	A	B	A
43.	50.	44.	41.	7.	3.	2.	3.	1.	1.	0.	1.
67	28	82	04	47	44	29	44	14	14	57	14

**Table 6 Comparison of Miraculous demonstrations are effective in initiating scientific enquiry (Before-After)**

SA %		A %		NI %		DA %		SDA %		NR %	
B	A	B	A	B	A	B	A	B	A	B	A
32.	37.	43	42.	16.	9.	4.	6.	1.	3.	2.	0.
18	35	.1	52	66	77	02	32	72	44	29	57

**Table 7 Comparison of Miraculous demonstrations should be incorporated in chemistry curriculum (Before-After)**

SA %		A %		NI %		DA %		SDA %		NR %	
B	A	B	A	B	A	B	A	B	A	B	A
1.	1.	3.	3.	10.	10.	22.	20.	60.	63.	1.	0.
72	72	44	44	34	34	41	68	91	21	14	57

**Table 8 Comparison of turning salty water of sea into sweet water and drinking of milk by idols of God is a miracle (Before-After)**

SA %		A %		NI %		DA %		SDA %		NR %	
B	A	B	A	B	A	B	A	B	A	B	A
2.	5.	9.	4.	11.	13.	24.	18.	52.	59.		
87	17	19	02	49	21	13	39	29	19		

**Table 9 Comparison of A student while going to college by road; do not cross over a lemon with pins or chillies. I support his/her act (Before-After)**

SA %		A%		NI %		DA %		SDA %		NR %	
B	A	B	A	B	A	B	A	B	A	B	A
71.	74.	17.	19.	6.	4.	1.	0.	2.	0.	1.	0.
26	13	24	54	89	59	14	57	29	57	14	57

**Table 10 Comparison of Maharashtra eradication of black magic, evil and aghori practices bill, 2005 (known as black magic bill) passed by Government of Maharashtra in State Assembly, should be propagated among the people (Before-After)**

## 8. Analysis Using Percentile and Statistical Paired t-Test

The null hypothesis is rejected on the basis of the analysis of the students' attitudinal and affective performance in two items of positive polarity in before and after the treatment.

For other five positive polarity items paired t-test indicates the difference between opinions before and after is insignificant. Indicating that, for these items students have not changed their opinion in majority, however some students have changed the opinions in positive sense because the difference between means is positive.

For other three negative polarity items the difference between opinions before and after is insignificant. Indicating that, for these items students have not changed their opinion in majority; however some students have changed their opinions in positive sense because the difference between means is negative. Based on the percentile result analysis, null hypothesis for the items should be rejected though the increase in response is not statistically significant.

The null hypothesis (H<sub>0</sub>) stands rejected for the overall effect of the treatment of the miraculous demonstrations in developing interest in chemistry and eradication of superstitions associated with it as the p value is 0.006 i.e. less than 0.05.

Hence the researcher accepts H<sub>1</sub> i.e. there is a statistically significant change in the attitudes of the students after the treatment of the miraculous demonstrations in developing interest in chemistry in students and eradication of superstitions associated with it.

Pair of items	N° pairs	Means	Difference	Std. Dev.
Pre18 Post15	174 174	1.7471 1.5345	0.2126	0.9347
Pre 21 Post 11	174 174	1.8103 1.6667	0.1437	1.1054
Pre 23 Post 12	172 172	1.6279 1.5640	0.0640	0.9742
Pre 25 Post 17	174 174	4.0977 4.0920	0.0057	1.2469
Pre 26 Post 18	171 171	1.7076 1.6316	0.0760	0.9580
Pre 27 Post 19	171 171	1.7076 1.6374	0.0702	0.9367
Pre 29 Post 28	169 169	1.9763 1.9645	0.0118	1.2535
Pre 31 Post 29	171 171	4.3977 4.4035	-0.0058	1.1193
Pre 32 Post 30	174 174	4.1379 4.2241	-0.0860	1.4340
Pre 33 Post 31	171 171	1.4444 1.3275	0.1170	0.9872
Total Score- B Total Score -A	174 174	11.8620 11.1720	0.6900	3.5770
Pair of items	H <sub>1</sub>	T-value	P-value	Decision
Pre18 Post15	> 0	3.00	0.002	Reject H <sub>0</sub>
Pre 21 Post 11	> 0	1.71	0.044	Reject H <sub>0</sub>
Pre 23 Post 12	> 0	0.86	0.195	Accept H <sub>0</sub>
Pre 25 Post 17	< 0	0.06	0.524	Accept H <sub>0</sub>
Pre 26 Post 18	> 0	1.04	0.150	Accept H <sub>0</sub>
Pre 27 Post 19	> 0	0.98	0.164	Accept H <sub>0</sub>
Pre 29 Post 28	> 0	0.12	0.451	Accept H <sub>0</sub>
Pre 31 Post 29	< 0	-0.07	0.473	Accept H <sub>0</sub>
Pre 32 Post 30	< 0	-0.79	0.214	Accept H <sub>0</sub>
Pre 33 Post 31	> 0	1.55	0.062	Accept H <sub>0</sub>
Total Score- B Total Score -A	> 0	2.54	0.006	Reject H <sub>0</sub>

**Table 11 Paired t-test result for ten pairs (pre and post) of Likert items (Note: H<sub>0</sub>: There is no change in opinion. H<sub>1</sub>: There is change in opinion.) (Before-After)**

If p-value is less than 0.05, we reject null hypothesis (H<sub>0</sub>) and accept alternative hypothesis (H<sub>1</sub>).

## 9. Conclusion based on Percentile and Statistical Analysis

The null hypothesis is rejected on the basis of the analysis of the student's attitudinal and affective performance in two items of positive polarity in before and after the treatment. For other five positive polarity items, paired t-test indicates the difference between opinions before and after is insignificant. Indicating that, for these items students have not changed their opinion in majority, however some students have changed the opinions in positive sense because the difference between means is positive. For other three negative polarity items, paired t-test indicates the difference between opinions before and after is insignificant. Indicating that, for these items students have not changed their opinion in majority, however some students have changed the opinions in positive sense because the difference between means is negative. It may therefore be concluded that the development of a booklet and miraculous demonstrations carried out in the research study, if delivered to the students in the suggested format, fosters among the students interest in chemistry and eradication of superstitions.

From the above discussions the researcher concludes for the selected sample of the students. The following conclusions are being in accord with that of Bodner [9], Carpenter & Minnix [10], Cunningham [11], Dantano & Beisenherz [12], Klopfer [13], Misra [14], O'Brien [15], Rao [16], Taylor [17].

1) The miraculous demonstrations are liked by the students as an attempt to develop interest in chemistry because for developing interest in chemistry students' views (Pre test Q. 7) are such that 54.02% said 'Using demonstrations.

2) Many students do not know the science or the scientific principle behind the so called miracle. The views of the students for intervening questionnaire Q.3 'Do you know the reason or science behind above mentioned miracle? Yes / No' are that 78.73% of the students replied 'No' and 21.26% of the students replied 'Yes'. When further asked to students who replied 'Yes' that 'If yes, give details of it', then out of 21.26% of the students only 4.59% of the students could write correct details of it, whereas remaining 16.66% of the students gave incorrect details. It indicates that in all about 95.39% of the students' population from the

sample do not know correct reason behind the so called miracle.

3) The students were eager to know the science behind the so called miracles. When asked to 78.73% of the students who have replied 'No' to an intervening question Q. 3 that, 'If No, would you like to know the reason behind of it? Yes / No' then 82.18% of the students replied 'Yes'. Again it indicates the need to convey the correct knowledge and information to all the students. The booklet prepared by the researcher and 'live' miraculous demonstrations serve this purpose.

4) The students are motivated for learning of chemistry using the miraculous demonstrations. By considering only the agree responses it was found that there is a positive effect of the miraculous demonstrations. There is 7.21% of the increase in 'total agree' response from 89.64% (pre) to 96.85% (post) (Table 1).

5) The scientific process of inquiry is initiated by using the miraculous demonstrations. By considering only the agree responses it was found that there is a positive effect of the miraculous demonstrations. There is an increase of 2.83% in 'total agree' response from 88.49% (pre) to 91.32% (post) (Table 6).

6) The results of the research study about the inclusion of the miraculous demonstrations in the curriculum of chemistry were communicated to the chairman and members of the board of studies in chemistry and Dean of the faculty of science of the University of Pune. In principle, the chairman and the Dean agreed and assured to consider the proposal in the concern meeting.

By considering only the agree responses it was found that there is a positive effect of the booklet of the miraculous demonstrations and 'live' demonstrations performed. There is an increase of 4.59% in 'total agree' response from 75.28% (pre) to 79.87% (post) (Table 7).

7) The results of the study showed that as an effect of the treatment, the belief in so called miracles is decreased from the minds of students to a very limited extent as it is related with the attitudinal and affective component of the students. By considering only the disagree responses it is found that there is a limited positive effect of the miraculous demonstrations. There is an increase of 0.57% in 'total disagree' response from 83.32% (pre) to 83.89% (post) (Table 8). This limited increase in the percentage view of students is due to the effect of the

treatment of the miraculous demonstrations. The attitudinal and affective aspects are difficult to change quickly. The researcher has not expected a major change in the responses measuring affective and attitudinal aspects of the students.

8) The results of the study shows that as an effect of the treatment, the belief in superstition like karani is decreased from the minds of the students to a very limited extent as it is related with the attitude of the students. By considering only the disagree responses it is found that there is a positive effect of the miraculous demonstrations. There is an increase of 1.16% in 'total disagree' response from 76.42% (pre) to 77.58% (post) (Table 9). This limited increase in the percentage view of the students is due to the effect of the treatment of the booklet and the 'live' miraculous demonstrations. The attitudinal and affective aspects are difficult to change quickly. The researcher has not expected a major change in the affective and attitudinal aspects.

9) In an overall (Table 11), the concepts in chemistry like colour change during reaction due to the presence of an indicator and the exothermic reactions generally leading to the combustion are very well introduced to the students in an interesting and the surprising way by using the booklet and 'live' miraculous demonstrations. It has

## 10. References

- [1] Ranganathan S. The Magic in Chemistry. Hyderabad: Vidyanantha, 2001
  - [2] Sanchowala C J & Dhiman R P. Fun with Chemistry - A Handbook of Demonstrations. Ahmedabad: Vikram A. Sarabhai Community Science Centre, 1990
  - [3] Roesky H W & Mockel K. Chemical Curiosities. Inc, NY: VCH Verlagsgesellschaft, Weinheim and VCH Publishers, 1996
  - [4] Premananda B. Science Versus Miracles: Vol.1. Podanur: Indian Skeptic, 1994
  - [5] Zade V S. Vaigynik Chamatkar va Buvabaji. Nagpur: Lok Sahitya Kendra, 1995
  - [6] Pawar K. Chamatkaranchi Duniya. Mumbai: Manovikas Prakashan, 1998
  - [7] Gupta V. Chamatkar Ka Rahassya. New Delhi: Vigyan Prasar, 2001  
Mandape K & Potadar P. Sanhita Chamatkar Sadarikarnachi. Satara: Maharashtra Andhashraddha Nirmoolan Samiti, 2007
  - [8] G. Bodner, Constructivism: A theory of Knowledge, JCE - Journal of Chemical Education, 1986, 63, 873-878.
  - [9] D.R. Jr. Carpenter & R.B. Minnix, The Lecture Demonstrations: Try it, they'll like it, The Physics Teacher, 1981, 19, 391 – 392.
  - [10] H. A. Cunningham, Lecture Demonstration Versus Individual Laboratory Method in Science Teaching – A summary, Science Education, 1946, 30(2), 70-82.
  - [11] M. Dantano & P.C. Beisenherz, Don't Just Demonstrate – Motivate!, The Science Teacher, 1990, 57, 27 – 29.
  - [12] Klopfer L E. Evaluation of Learning in Science, In Bloom, B.S., Hastings, J.T. & Madaus, G.F.(Ed.). Handbook on Formative and Summative Evaluation of Student, Learning. McGraw-Hill Book Company, 1971
  - [13] Misra K.S. Developing Scientific Attitude, In D. B. Rao (Ed.). Reflections on Scientific Attitude, New Delhi: Discovery Publishing House, 1997
  - [14] T. O'Brien, The Science and Art of Science Demonstrations, JCE - Journal of Chemical Education, 1991, 68, 933-936.
  - [15] Rao D B. Place of Scientific Attitude in the Objectives of Science Teaching, In D. B. Rao (Ed.). Reflections on Scientific Attitude. New Delhi: Discovery Publishing House, 1997
  - [16] Taylor, C. The Art and Science of Lecture Demonstration. Philadelphia: Adam Hilger, 1988
- 
-



## Elucidating and Teaching the Structure of DNA to Biology Students

V.K. Adi

Department of Biotechnology, Bapuji  
Institute of Engineering and Technology,  
Davangere 577004, Karnataka, INDIA  
drveena.adi@gmail.com

**Abstract.** The biology opted students must be familiar with the biochemical basis of genetic material namely DNA, and the concept of inheritance and pattern among various living species. The purpose of this presentation is to introduce budding scientist to the structural concept of DNA. Here, I am presenting the simple and fun creating means to elucidate DNA structure. By creating this fun DNA thermo coal ball model, students will be able to appreciate how the base pairs have specific matching requirements (Adenosine to Thymine, Guanine to Cytosine) and that different combinations of these bases are what create unique characteristics in individuals.

**Keywords:** DNA, double helix, adenine, guanine, thymine cytosine.

### 1. Introduction and Background Science knowledge

As long as the structure of DNA was unknown there was no meaningful way to think about the nature of the genetic code or how the genome is replicated. In 1869, Friedrich Miescher discovered a substance he called the "nuclein molecule" because he found it in the nucleus of the cell. This molecule was actually deoxyribonucleic acid, or DNA, the building block of life. Over the next 80 years, scientists worked with this substance to identify its characteristics and determine its function. During the 1950's a considerable amount of evidence concerning the structure of DNA had accumulated an intense effort was underway to solve the structure of DNA. This was considered to be one of the paramount problems in biology. In 1953, James Watson, Francis Crick, Rosalind Franklin, Maurice Wilkins, and Raymond Gosling identified the structure of DNA (1, 2) as

a double helix. However, noble prize was awarded to Watson, crick and Wilkins. They studied the structure of DNA their widely accepted model that is Double Helix Model of DNA has six main features and are follows,

1. Two polynucleotide chains wound in a right-handed (clockwise) double- helix.
2. Nucleotide chains are anti-parallel:  
 $5' \rightarrow 3' \quad 3' \leftarrow 5'$
3. Sugar-phosphate backbones are on the outside of the double helix, and the bases are oriented towards the central axis.
4. Complementary base pairs from opposite strands are bound together by weak hydrogen bonds. Strictly Adenine pairs with Thymine (2 H-bonds), and Guanine with C (3 H-bonds).  
e.g.,  $5'-TATTCCGA-3' \quad 3'-ATAAGGCT-3'$
5. Base pairs are 0.34 nm apart. One complete turn of the helix requires 3.4 nm (10 bases/turn).
6. Sugar-phosphate backbones are not equally-spaced, resulting in major and minor grooves

The double helix that you are going to build in this project contains balls that specify the different components of DNA. These mentioned bonding rules will be important as the student approach the Thermo Coal Ball DNA model. Only specific balls can be used to accurately depict the structure of DNA.

### 2. Materials

The following are to be procured from any stationary shop in order to elucidating the structure of DNA.

1. About a meter of two different coloured (red and green), soft, flexible, thin metal wire. → Acting as Rugs (strands). Red acting as sense strand while green as anti sense strand.
2. Two different sized thermo coal balls of different colour containing at least 200 balls are used as representative for i) Large white colour: as Phosphates (Large ball) and ii) Small white colour: as Sugar (small ball).
3. Two different sized orange thermo coal balls (100 balls) are used to represent Pyrimidines i) Large orange balls: as

- Thymine (T) ii) Small orange balls: as Cytosine (C).
4. Two different sized green thermo coal balls (100 balls) are used to represent purines
    - i) Small green balls: as Adenine (A)
    - ii) Large balls: as Guanine (G).
  5. Wire cutter.
  6. Pliers.
  7. Thick and strong thread.

### 3. Procedure

As a rule of double helix, sugar and phosphates are to be fixed on the outer side of the helix. And as already mentioned large white coloured balls represent phosphate and small white coloured balls represent sugar.

The following steps are to be followed to enjoy this fun creating thermo coal ball modelling of DNA.

- I. Creating the backbone helix - phosphodiester bond
- II. Connecting the base to the backbone
- III. Connecting the bases of the helix - hydrogen bonding

To generate the DNA thermo coal ball model following steps are to be followed

1. Take 2 metal wires. They act as sense and anti-sense strand of DNA.
2. To one of the wire, string a small white ball and this is the growing end.
3. To the other wire string the large white ball first and a small white ball next and this is the growing end.
4. Now the growing ends of both the wire have small balls, which represent deoxy ribose sugars.
5. Now you need to fix bases. And to fix this you need to follow certain rules. (A pairs with T ; G pairs with C)
6. To one of the wire (sense strand) string any one type of ATGC represented by orange- small/large balls or green - small /large balls.
7. To the other strand i.e. anti-sense strand, string the respective pair of base.
8. Again come back o h same position in the reverse direction and reach the sugar. By doing this I want you to create loop near the base.
9. Do the same with the sugar on the other wire

10. Now you have two loops on the both the wire, using a thread join them with a knot
11. Now, again begin working at the growing and of the wire. Redo and repeat step 2 to step 10. You will have a long stretch of DNA strand.

### 4. Result:

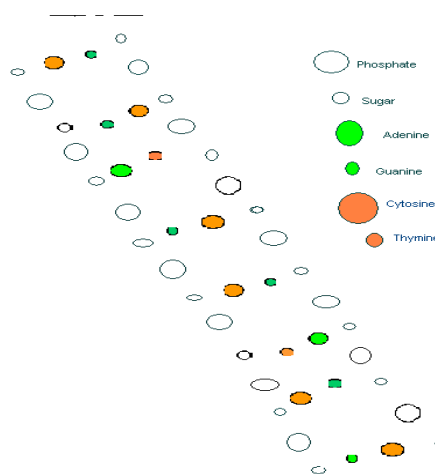


Fig: DNA represented in simple colours

### 4. Discussion

The students need to know the following information regarding DNA. The Nucleotides are the fundamental building blocks of DNA and RNA. Each nucleotide comprises of nucleoside and a phosphate group. In other words each nucleotide has three components 1) Pentose sugar, 2) Nitrogen base 3) Phosphate group. The nucleoside comprises of a base and a sugar. In case of DNA the sugar will invariable be Deoxy-ribose sugar. The nitrogen bases are of two types, i) the bicyclic purine represented by A and G and the) the monocyclic Pyrimidine represented as C and T. The ends of the DNA (also of RNA) chain are not the same. One end of the chain has a 5' carbon and the other end has a 3' carbon.

Nucleotides are linked by phosphodiester bonds to form polynucleotide. The Phosphodiester bond are covalent bond between the phosphate group (attached to 5' carbon) of one nucleotide and the 3' carbon of the sugar of another nucleotide. This bond is very strong, and for this reason DNA is remarkably stable. DNA can be boiled and even autoclaved without degrading! Hydrogen bonding is also important for the specificity of the base pairing. Suppose to

pair and adenine with a cytosine, NH<sub>2</sub> grouped at C6 of adenine and C4 of cytosine lie opposite each other. Water would have to be stripped off the donor and acceptor group, which leads to instability (3, 4)

## 5. Conclusion

The model gives a clear picture of DNA; it helps if you can imagine 2 helical chains with each one coiled around the same axis. In this presentation, I have depicted in a simplified model of DNA using coloured thermo coal balls and wire. You can use them for decoration, hang them in a window, use them as designer curtains or even gift your molecular biology teacher.

## 6. Acknowledgements

I thank the management, Principal and HOD of Biotechnology, Bapuji Institute of Engineering and technology for their encouragement and support in all my endeavours.

## 7. References

The idea of making jewellery is seen in some of the articles, but using the model as curtains and window hangings is the author's innovative inception of idea. However, following are the references.

- [1] Watson, J.D., and Crick, F.H.C. 1953. "Molecular Structure of Nucleic Acids. A Structure for Deoxyribose Nucleic Acid." *Nature* 171:737-738.
  - [2] Watson, J.D. 1980. *The Double Helix: A personal account of the discovery of the structure of DNA.* W.W. Norton and Co., New York.
  - [3] Felsenfeld, G. 1985. "DNA." *Scientific American* 253(4):58-67.
  - [4] Mirsky, A.E. 1968. "The Discovery of DNA." *Scientific American* 218(6):78-88.
- 
- 

## Andhra Pradesh National Green Corps: Creating the Next Generation of Environmental Leaders

V.Gurunadha-Rao

APNGC Training Officer & Environment Educator, S.A (Physical Sciences), Z.P.S.S-Parvathagiri-506101, Mahabubabad (Mandal); Warangal District; A.P, INDIA  
nath\_voore@yahoo.com

**Abstract** We all know that we are part of the environment we live in, and the solution to many environmental problems lie in our attitude towards environment-be it awareness to keep our surroundings clean or the realization to conserve natural resources by re-using and recycling wherever possible. On the surface, it looks simple. However, changing the attitudes of people is not going to happen overnight. The best way is to initiate community into action through children. They have no stakes. They are impressionable. They are our future. They are the single most important influence in any family. Accordingly, the Ministry of Environment & Forests, Government of India have launched the National Green Corps (NGC) programme in all the districts in Andhra Pradesh, i.e., 250 schools in each district covering 5750 schools with NGC eco-clubs. Today Environmental Movement in our country lacks focus on "Environmental Discipline". The need of the hour is to create Environmental Discipline in the younger generation. Earlier NGC Students Environment Movement was based on Environmental action. This was a step ahead from environmental awareness. Now since there is a need to move forward in order to protect our environment and ourselves, NGC took a stand to instill Environmental Discipline in eighth class students through five NGC Eco club teams in each NGC School. The first step is to promote disciplined movement and action promoting environmental discipline. This is a clear shift of NGC from environmental knowledge promotion to environmental discipline promotion. National Green Corps programme aims at spreading 'environmental discipline' among schoolchildren and involves them in environment related actions in the schools and communities. Children have

infectious enthusiasm. They are custodians of natural resources and nature. This paper has opened avenues to understanding the extent of the National Green Corps (NGC) program in a state that is the first to have up scaled this program to include all the schools in its jurisdiction. This paper has been based on field visits to schools, discussions with groups of teachers, interactions with personnel from the education department, NGO's, bureaucrats and staff at the NGC Directorate besides accessing secondary material such as reports, environment education material developed, etc. The recommendations are thus based on quantifying the activities over the last five years as well as documenting the subjective perceptions of a large number of individuals.

**Keywords:** eco club teams, environmental action, environmental discipline, National Green Corps, NGC camps, NGC themes.

## 1. Introduction

We all know that we are part of the environment we live in, and the solution to many environmental problems lie in our attitude towards environment-be it awareness to keep our surroundings clean or the realization to conserve natural resources by re-using and recycling wherever possible. On the surface, it looks simple. However, changing the attitudes of people is not going to happen overnight. The best way is to initiate community into action through children. They have no stakes. They are impressionable. They are our future. They are the single most important influence in any family. Accordingly, the Ministry of Environment & Forests, Government of India have launcher the National Green Corps (NGC) programme in all the districts in Andhra Pradesh, i.e., 250 schools in each district covering 5750 schools with NGC eco-clubs. Conservation action at the individual level must go through a range of personalized processes. This happens at a conscious as well as at a subconscious level in an individual. This process passes through a range of stages that includes receiving environmental information, developing an enhanced state of awareness, creating a concern for the environment and finally into pro-conservation action. While this happens spontaneously in the lives of some individuals through a gradual and subtle process

in others it is triggered through single or a few key episodes in the course of their lives. It is important to appreciate that the initiating processes that enhance environmental concepts are related to exposure to nature and other environmental issues during the early formative years of an individual's life. This develops pro-environmental insights in a young person who later grows into a conservation conscious adult. The nature and scope of environment education and awareness generating sector needs a clear appreciation of the value of our environmental assets, how they affect our lives, how these assets are destroyed by short sighted approaches to development and what can be done about preserving these natural assets through personal actions. This paper has opened avenues to understanding the extent of the National Green Corps (NGC) program in a state that is the first to have up scaled this program to include all the schools in its jurisdiction. This paper has been based on field visits to schools, discussions with groups of teachers, interactions with personnel from the education department, NGO's, bureaucrats and staff at the NGC Directorate besides accessing secondary material such as reports, environment education material developed, etc. The recommendations are thus based on quantifying the activities over the last five years as well as documenting the subjective perceptions of a large number of individuals.

## 2. Background

With the realization that children are a very powerful media to institute change in society, the Ministry of Environment and Forests, Government of India has launched the National Green Corps Program in all districts of India. National Green Corps is a students' movement initiated by the Ministry of Environment and Forests for promoting environmental action orientation and to supplement the endeavours of the Ministry of Human Resource Development in greening of the curriculum. The main objectives of this program are to educate children about their immediate environment and impart knowledge about the eco-systems, their inter-dependence and their need for survival, through visits and demonstrations and to mobilise youngsters by instilling in them the spirit of scientific inquiry into environmental problems and involving them in the efforts of

environmental preservation. Under this program, eco-clubs are being set up in 250 schools of each District of the country. This program is being implemented in each State/UT through the Nodal agency appointed by the State/UT Govt. The Government of India provides financial assistance for establishment of Eco clubs @ Rs.2500 per Eco-club, Training of Master Trainers, teacher training and distribution of resource materials. The NGC program in Andhra Pradesh (AP) is presently being implemented by the Directorate of National Green Corps a separate body that was established for this program in the state. The program is being implemented in class 8 of all the Government and private schools in the state numbering 17,050. Of this 5750 schools are funded by the MoEF and 16,000 schools including the 5750 schools supported by MoEF are either provided with resource material or provided funds by the State Government. Some components of the program have also been introduced in 72,000 primary and upper primary schools in the state in collaboration with the Sarva Shiksha Abhiyaan (SSA).

### **3. Findings-Strengths**

This review has focused on evaluating the present strengths and weaknesses of the National Green Corps program in Andhra Pradesh.

#### **Program design**

While some states in the country are still grappling with the implementation of the NGC program, Andhra Pradesh has become the first state in the country to upscale the National Green Corps to cover all the schools in the state through the establishment of the Directorate of National Green Corps. This is a tremendous step towards developing a cadre of environmentally aware citizens.

It has also been the first and only state in the country to implement the Supreme Court's decision on environment education in formal curricula by preparing special textbooks for standards 1 to 10. This is unprecedented in the country.

The NGC program has been appropriately designed to ensure effective implementation. The NGC team has developed a close collaboration with key individuals in the Education

Department even on a personal level ensuring adequate support for the program.

#### **NGC Environmental Discipline**

Today Environmental Movement in our country lacks focus on "Environmental Discipline". The need of the hour is to create Environmental Discipline in the younger generation. Earlier NGC Students Environment Movement was based on Environmental action. This was a step ahead from environmental awareness. Now since there is a need to move forward in order to protect our environment and ourselves, NGC took a stand to instill Environmental Discipline in 8<sup>th</sup> class students through 5 NGC Eco club teams in each NGC School. The first step is to promote disciplined movement and action promoting environmental discipline. This is a clear shift of NGC from environmental knowledge promotion to environmental discipline promotion.

National Green Corps programme aims at spreading 'environmental discipline' among school children and involves them in environment related actions in the schools and communities. Children have infectious enthusiasm. They are custodians of natural resources and nature.

We all know that we are part of the environment we live in, and the solution to many environmental problems lie in our attitude towards environment-be it awareness to keep our surroundings clean or the realization to conserve natural resources by re-using and recycling wherever possible. On the surface it looks simple. But changing the attitudes of people is not going to happen overnight.

The best way is to initiate community into action through children. They have no vested interests. They are impressionable. They are our future. They are the single most important influence in any family.

Activities:

1. Building 5 NGC natural resource management teams in each school and conducting NGC weekly parade drill for 20 weeks along with band.

2. Conducting Daily Natural Resource Monitoring through 5 NGC students' teams and Annual School Environmental Audit by November every year.

3. Participating in District level parade on 15<sup>th</sup> August Independence Day and 26<sup>th</sup> January Republic Day.

4. NGC Eco Club Student Cadets will be in charge of retaining cleanliness in the mid day meals or daily lunch time and also greening the school premises.

In the above context NGC trains PET/PD of the selected/registered schools. The NGC training program covers parade drill and natural resource conservation monitoring and environment audit.

#### **Objectives**

- To create environmental discipline among school children.
- To train young students for environment action.
- To utilize the unique position of school children for awareness of the society at large.
- To facilitate children's participation in decision making in areas related to environment & development.
- To bring children into direct contact with the local environmental challenges and respond positively.
- To involve children in disciplined action based programmes related to environment in their neighbourhood.

#### **Selection of Schools**

All the government Higher/High schools, Government Aided schools, Private schools, APREIS, APTWREIS, APSWREIS, Kendriya Vidyalayas, Navodaya Vidyalayas, CBSE schools and ICSE schools can opt to join the programme.

Schools with prior experience in Eco-clubs or other environmental action programmes would be given preference.

School PET/PD, will be the School NGC Officer.

This PET/PD who is below 45 years age is eligible.

Principal/Head Master/Mistress and PET/PD should submit a letter indicating the willingness through the concerned Head Master/Principal to [ngcapschool@gmail.com](mailto:ngcapschool@gmail.com).

#### **Selection of Students**

Each member school may select 40-50 students, with interest in environmental discipline including parade. The students should be from VIII standard

Selection of students should be purely based on their interest in discipline and physical fitness

#### **Financial Assistance**

Each NGC School will be given an annual grant of Rs.2500/-

This amount will be spent on refreshments at Rs.100/- for each NGC weekly drill i.e., @Rs.2/- per child for 2 bananas etc for 20 weeks amounting to Rs.2000/- and remaining Rs.500/- will be the NGC officer honorarium for conducting 20 weeks of NGC drill and NGC band practice.

#### **NGC Parade Foot Drill**

The aim of the drill is to inculcate discipline, improve smartness in appearance, turnout, and self confidence and to develop qualities of team spirit and obedience in the cadets

#### **NGC Camps**

Let's Learn and enjoy

AP NGC is promoting 'environmental discipline' amongst students through NGC Eco Clubs. Promoting environmental discipline and action are on the agenda for conducting camps at various towns in Andhra Pradesh

Each NGC Camp will cover the following aspects:

1. Drill practice
2. Band practice
3. Natural resource use monitoring and auditing.
4. Visit to locations environment improvement activities

#### **Why Camping?**

The roads, transport, management of solid waste and sewage safe drinking water, biodiversity conservation, maintenance of natural tree cover, refuge for wildlife and use of alternative sources of energy can be observed and learnt. NGC Camps help in practicing intensively is learnt in NGC.

The saying 'Cleanliness is next to Godliness' comes to life in Tirumala. TTD endeavours to practice it. The NGC-TTD Camp is an inspiration to adopt these principles in our lives.

#### **Who can participate?**

NGC organizes 2-3 camps in each location per month. Each camp is conducted for 10 days. The campers are selected division-wise from every district. 5 NGC Training Officers and 50 students of VIII class from each district are selected for each camp. Each camp is for 5 NGC Training Officers and 50 students. The camps are open to NGC schools priority is for schools with active NGC Eco-clubs.

#### **Activities at the NGC Camp**

NGC cadets, who are VIII class student campers, will undertake the following activities during their 10-day stay at the NGC Camp.

1. Participate in Natural resource monitoring and auditing everyday.
2. Visit alternate energy run facilities.
3. Observe and understand the functioning of wind mills.
4. Visit the drinking water treatment facilities and sewage treatment plants.
5. Learn about the solid waste management facilities.
6. Visit the National Parks/Zoo and adjoining forests. Learn from nature, natural rock formations and wildlife.
7. Practice daily physical drill and parade.
8. Practice band.
9. Visit medicinal plant centre and learn about ayurvedic medicine preparations.
10. Prepare a report their observations and activities each day and discuss with fellow campers.

#### **Facilities at the NGC Camp**

Teachers and students attending the camp will receive TA for travelling from their hometown to camp and back. NGC shall provide accommodation, food and other basic needs.

APNGC will provide transport for visits to different locations within the camping location. Further, all campers will receive participation certificates from NGC.

#### **Activities after attending the Camp**

On returning from the 10 day NGC camp, every participant is expected to complete the following tasks:

1. Share the findings with school management, other NGC students and non NGC students.
2. Explain the duties as citizens of India, towards conserving nature.
3. Based on experience at the camp, identify at least one aspect of the village or town where change can be brought.
4. Initiate action to bring that change.

Welcome to the NGC camp! Join in our mission to make India an environment friendly and a progressive nation.

#### **NGC Eco Club Teams**

Every school needs to form five NGC natural resource management teams. All 8<sup>th</sup> class students in the school could fall into either of these teams. Students could shift membership later based on their shifting interest.

These five school level NGC natural resource management teams are

1. Biodiversity Management Team: Responsible for the flora and fauna in the school.
2. Water Management Team: Responsible for the drinking and waste water.
3. Beautification Team: In charge of reducing, reusing, recycling and composting of waste.
4. Energy Management Team: In charge of energy audit and conservation.
5. Land use Management Team: Planning and conducting of vehicles movement to and fro in the school. Plan for water storage, parking, playground and park.

#### **NGC Themes**

Some of the NGC Activity themes are:

House hold garbage management, Hospital waste disposal, water pollution, shortage and conservation, Air pollution, Civic amenities and their care, School and community plantation, Cleanliness of public parks and gardens, Cleanliness and composting of vegetable and fruit market wastes, Cleanliness at bus stands, railway stations and public places, Study and conservation of Ecosystems, Discovery and documentation of the role of local Bio diversity, Fuel Energy and resource conservation.

The reporting mechanism involves the participation of the Education Officer which in turn ensures monitoring. Although the effective monitoring may or may not happen, this mechanism however ensures that NGC agenda gets the necessary attention and support. The Headmaster of the schools has been named as the NGC Captain and the in charge teacher as the NGC vice Captain. A simple designation ensures the support of the school heads for the program which is otherwise left solely to the teacher in charge.

The themes of the NGC program have been designed effectively so as to leverage both the occasion and the social activity enhancing its relevance. The NGC annual action plan links environmental issues to the season and the social activity taking place at community level during that month. It is planned in such a way that the purpose and the process are made very clear to the participants in National Green Corps and in the local community. All these activities are conducted at four levels i.e., NGC group level, school level, neighbourhood school level and the community level.

Apart from this the program encourages the celebration of several environmental days and also conducts summer camps, a month long environment activity program and the students' environmental congress.

#### 4. Conclusions

Andhra Pradesh National Green Corps (APNGC) is an organization whose primary objective is to spread environmental action orientation among students in the state, from school to university level. NGC aims to involve students of all levels in the country in the environmental movement for conservation. The school unit will oversee the work done by the various NGC units in each of the classes/teams in the school. The school unit will also set certain works/goals for the class NGC units every month. It has to also keep the tempo of environmental activity in the school at an active level, always providing it with motivation, direction and thrust. Each of the items in the action plan is linked to the season and the socio-cultural activity that takes place at the community level during the month. It is planned in such a way that the purpose and the process are very clear to the participants in National Green Corps and in the community. Remember, our travel should not become travail for others. Let us give it a thought; let us become more considerate towards fellow beings; let us change our attitude and bring in a change. Today Environmental Movement in our country lacks focus on "Environmental Discipline". The need of the hour is to create Environmental Discipline in the younger generation. Earlier NGC Students Environment Movement was based on Environmental action. This was a step ahead from environmental awareness. Now since there is a need to move forward in order to protect our environment and ourselves, NGC took a stand to instill Environmental Discipline in eighth class students through five NGC Eco club teams in each NGC School. The first step is to promote disciplined movement and action promoting environmental discipline. This is a clear shift of NGC from environmental knowledge promotion to environmental discipline promotion. National Green Corps programme aims at spreading 'environmental discipline' among schoolchildren and involves them in environment related actions in the schools and communities. Children have

infectious enthusiasm. They are custodians of natural resources and nature. "Nothing could be more important than training the next generation of environmental leaders—they are the future of the future. And no one has done it more consistently than Andhra Pradesh National Green Corps." The national green corps (NGC) should be given a status similar to the national cadet corps (NCC). Already the state government set up a directorate of NGC affiliated to the ministry of environment and forests on the lines of the directorate of NCC, which is affiliated to the defence ministry. The national green corps should get certificates similar to the ones given to NCC cadets. We wish them a happy journey into joyful and fruitful environment education. Green Corps alumni leading the charge, the promise of a green and renewable tomorrow burns bright.

#### References

- [1]. APNGC green hand book 2009
- [2]. APNGC green hand book sadhana 2007, 2008
- [3]. Shamita Kumar Vice Principal Institute of Environment Education and Research Bharati Vidyapeeth University Pune Evaluation Report of the National Green Corps Program in Andhra Pradesh April 2008
- [4]. Green Corps: Growing the next generation of green leaders Website: [www.greencorps.org](http://www.greencorps.org) Third Coast Digest [2009-08-01]
- [5]. U.S. Department of Agriculture Agricultural Research Service. [www.ars.usda.gov/News/docs.htm?docid=15572](http://www.ars.usda.gov/News/docs.htm?docid=15572) (Accessed September 2008).

Year	Total No. of schools	Supported by MOEF	Supported by State Edn Dept
2001-02	6800	2300	4500
2002-03	6000	2300	3700
2003-04	10900	2300	8600
2004-05	12050	3450	8600
2005-06	12500	3900	8600
2006-07	14350	5750	8600
2007-08	16000	5750	10250
2008-09	17050	5750	11300

Table .1 Growth of the program



Module type	Knowledge based modules	Modules for development of psychomotor and analytical skills	Activities for promoting the development of a pro-conservation attitude	No strong educational value but ensures visibility to the program
Environmental audit	✓	✓	✓	
Eco-rallies				✓
Eco-campaigns				✓
Eco-melas	✓	✓	✓	✓
Eco-exhibitions	✓	✓		✓
Model making	✓	✓		
Seminars	✓	✓		
Eco-debates	✓	✓		
Discussions	✓	✓		
Popular talks	✓			
Action projects	✓	✓	✓	✓
Street plays	✓	✓		✓
Human Chains				✓
Plantation				✓
Cleanliness		✓		
Inventorying and reporting polluting sources	✓	✓	✓	✓
Environmental Congress	✓	✓	✓	✓
NGC Parades				✓

**Table .2** Analyses of skills developed through the various NGC modules designed by the Directorate

## A Science-Field Teaching Module with Hands-On Experiments

<sup>1</sup> Chien Ho Chou, Chin Hsin Huang and

<sup>1</sup> Vin Son Hsieh

<sup>1</sup> The Physics Dept., <sup>2</sup> The Physical education. Dept., of National Kaohsiung Normal University, 813, N0.116, Ho-Ping first Rd. Kaohsiung, TAIWAN  
 t1620@knuc.nknu.edu.tw

**Abstract.** This is a study about how to design a native and integrate science-field teaching module with hands-on experiments, for the eastern coastal areas in Taiwan. It was found there could be three channels in the design style. First, characteristic scenery spots could be as the exploratory topics of the science experiments. Secondary, characteristic scenery spots could be as some parts of the science experimental equipments, or as materials of the hands-on experiment. Finally, the characteristic scenery spots related hands-on experiments were chose. A three days activity was run as a teaching experiment of this science-field teaching with hands-on for 41 students of grade seven. It is found that science learning will be back again in the real nature life in from student's feedback.

**Keywords:** teaching modules, school-based curriculum, field experiments.

## Hands-on Activities of Polymer

Chien Ho Chou and Chin Hsin Huang  
The Physics Dept., National Kaohsiung  
Normal University, 813, N0.116, Ho-Ping  
first Rd. Kaohsiung, TAIWAN  
t1620@nknucc.nknu.edu.tw

**Abstract.** Street Physics that has been famous in Taiwan for the recent years, is an innovative, and a brand-new ideal, and originality on the hands-on activities. A lot of interest, low cost hands-on activities of polymer that were used to help people to understanding they daylilies in Street Physics activities, are to be presented in this workshop.

**Keywords:** scientific hands-on, polymer.

---

---

## Plane Potential Fields. Theoretical Notions and Experimental Modelling

I. Ionita, A.D. Mateiciuc  
and A. Beteringhea  
Physical Chemistry Institute of the  
Romanian Academy, Spl. Independentei  
202, Bucharest, ROMANIA  
chemworks2003@yahoo.com

**Abstract.** The concept of physical field prevails in physics from the second half of the nineteenth century, as a fundamental concept to explain the transmission of interactions of nearby and remote being associated with each point describing the properties of a region of space, properties caused by corps preset in this regions. Many of the known physical fields satisfy Laplace relation. Laplace equation in the plane is mathematically device which characterizes the plane potential fields. In this work was reviewed mathematical device that characterize the electric field of charged infinite plane, plane electrostatic fields caused by a right-infinite, uniformly electrically charged and the electrostatic field produced by two parallel wires with equal charge densities and opposite sign. Because the mathematical approach is very complicated was tried modelling experiment of these fields with the

Nobili experiment. Coloured lines correspond to equipotential lines that would result from direct application of electrodes on a plane conductor with the same shape with copper plate covering the bottom of the bath used in this experiment.

---

---

## Water. A Host of Life

E. Niculescu-Mizil  
Liceul Teoretic C.A.Rosetti,Bucuresti  
17A, Armeneasca str.,sector 2, Bucuresti,  
ROMANIA  
niculescue@yahoo.com

**Abstract.** This is an interdisciplinary study of water in realized in a High school of Bucharest, Romania The paper studies the importance and the properties of water from different points of view. Many sciences study the water: Chemistry, Physics, Biology, Geography, Environmental sciences, but the water is important also for History, Economy, Sociology, Religion, Arts and so on.

The students from C.A.Rosetti High-school from Bucharest guided by their teachers realized some interesting studies of the water from physical properties to arts and economical importance of the water in our life, experiments about the physical and chemical properties of water, posters and CD's. The products are realized during the lessons from the curricula but also in non formal education activities.

## Physics Demonstrations on Dining Table

Ching-Chi Chu, Tsung-CeanTu  
and Hsiao-Ching Su

Department of Physics, National Central  
University No.300, Jhongda Rd., Jhongli  
City, Taoyuan County 32001, TAIWAN  
ccchu.ncu@gmail.com, tuchern@gmail.com,  
sunnygreta@gmail.com

**Abstract.** The authors use handy materials available on ordinary dining table to do several physics demonstrations. For examples, by using a fork and a spoon, we can perform an amazing equilibrium phenomenon. A wine glass is very helpful to demonstrate many concepts associated with surface tension and fluid dynamics. Candles are used to show a dynamical balance process. Olive oil and water construct a simple system to illustrate strange interface shapes appeared in rotating fluids. Paper baking cups can be used to study the relation between air drag force and velocity. Also, pepper, salt and sugar play their roles in our experimental design. People can definitely enjoy their dinner as well as those hands-on scientific shows.

**Keywords:** physics, demonstration, hands-on.

---

---

## Understanding Thermal Equilibrium through Hands-on Activities

S. R. Pathare, R. D. Lahane  
Homi Bhabha Centre for Science Education  
V. N. Purav Marg, Mankhurd. Mumbai  
400088. INDIA  
shirish@hbcse.tifr.res.in

**Keywords:** adiabatic, diathermic, thermal equilibrium, zeroth law of thermodynamics.

### 1. Introduction

The fact that the students have their own network of understanding of how the things work prior to receiving formal education is well accepted by the physics education researchers'

community. It is very well known that students enter classroom with their own understanding about the topics that they learn. This has been well established by many researchers.

Some preliminary studies conducted by us in students' misconceptions gave us some idea regarding their understanding about the concepts like pressure, heat, temperature.

There were many concepts with which students were not familiar with. The concept of thermal equilibrium was one such concept found to be falling under the category of non-conception rather than misconception. We felt a need to develop a learning material in terms of a kit which can be used by the students to understand this concept. This paper discusses various activities using the kit developed by us.

### 2. Learning by doing approach

The manner in which the subject of thermodynamics is introduced seems to be responsible for such a scenario. Lack of experimentation in the domain of basic concepts in thermodynamics, make students learn them without having a feel about the real life existence. Hence a hands on science approach becomes an essential factor while learning these concepts. The phrase 'Hands on science' has different meanings for different people. It is more than just handling apparatus and actually means a serious involvement of students in an investigative manner. It requires the student to have a feel about the choice of material, procedures and the developmental problems involved in that activity. Children, especially younger ones, learn science best and understand scientific ideas better if they are able to investigate and experiment. Hands-on science can also help children think critically and gain confidence in their own ability to solve problems. A paper on Syringe Thermodynamics is one such example where in students can understand concepts like hydrostatic pressure, adiabatic changes, work done using the syringes. With this approach in mind, we have developed a few activities to understand the concepts like adiabatic walls, diathermic walls, thermal equilibrium, zeroth law of thermodynamics.

### 3. The kit

#### 3.1 Material used to make the kit

The following materials were used to build the kits:

- a) Kit for Thermal Equilibrium:
  - i) Teflon container (80 mm × 80 mm × 50 mm)
  - ii) Teflon lid (100 mm × 100 mm × 5 mm)
  - iii) Two copper plates dividing the container in two equal chambers (80 mm × 52 mm × 2 mm)
  - iv) A cartridge heater
  - v) Two Cr-Al thermocouples connected to digital thermometer
  - vi) Adiabatic wall (80 mm × 50 mm × 5 mm)
  - vii) Diathermic wall (80 mm × 50 mm × 5 mm)
  - viii) A variac supply
- b) Kit for zeroth law of thermodynamics:
  - i) Teflon container (110 mm × 86 mm × 50 mm)
  - ii) 6 copper plates (50 mm × 50 mm × 2 mm each)
  - iii) Teflon square rod (15 mm × 15 mm × 52 mm)
  - iv) 3 Adiabatic and 2 Diathermic walls (50 mm × 50 mm × 5 mm each)
  - v) 3 thermistors
  - vi) A cartridge heater
  - vii) A variac supply
  - viii) 3 multimeters

#### 3.2 Construction

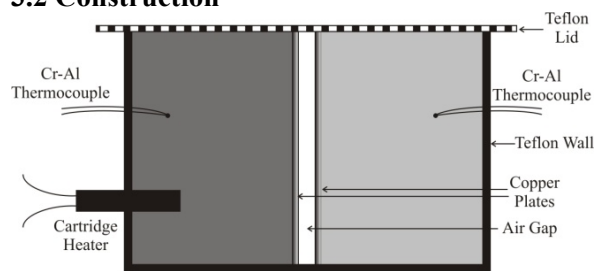


Figure 1. Apparatus for thermal equilibrium (Side View).

The apparatus consists of a Teflon container. Two copper plates are glued inside the container such that the container gets divided into two chambers. One chamber is fitted with a cartridge heater. The heater is being operated using a variac supply. A Cr-Al thermocouple is fitted inside each chamber. An air gap is maintained between two copper plates. The air gap can be replaced by adiabatic or diathermic wall depending upon the application.

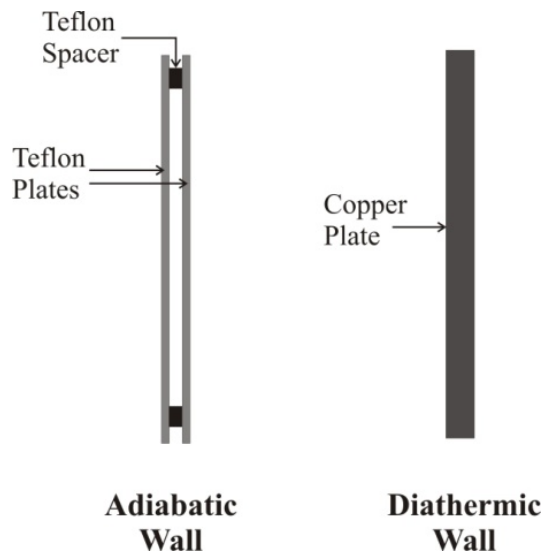


Figure 2. Adiabatic wall and Diathermic Wall.

- i) Adiabatic Wall: The adiabatic wall is made by two Teflon sheets separated by a teflon spacer allowing an air gap between the two plates.
- ii) Diathermic wall: The diathermic wall is a thick and blackened copper plate.

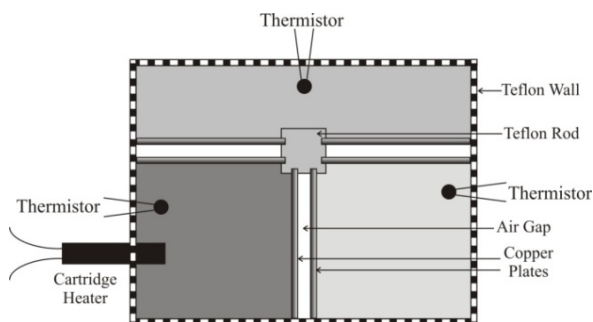
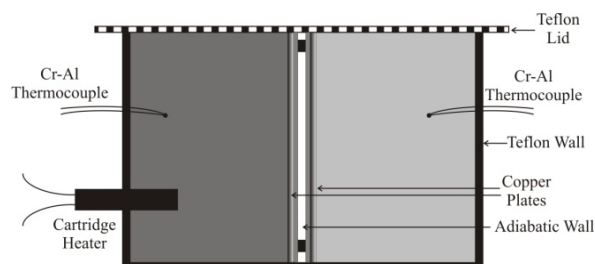


Figure 3: Apparatus for zeroth law of thermodynamics (Top View)

The apparatus consists of a Teflon container. 3 pairs of copper plates are glued in the container such that 3 chambers are formed inside the container. The copper plates are separated by an air gap such that adiabatic and diathermic walls can be inserted in that gap. Each chamber is fitted with a thermistor. A cartridge heater is inserted in one of the chambers. The heater is controlled by a variac supply.

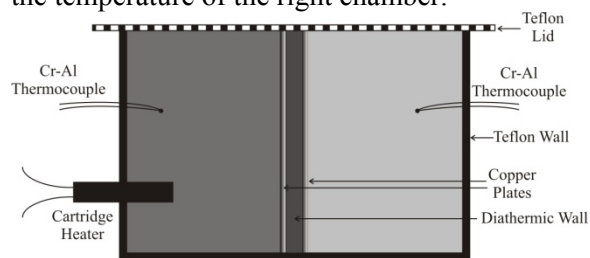
## 4. Operation

### 4.1 Thermal Equilibrium



**Figure 4. Apparatus for the thermal equilibrium (Adiabatic Wall inserted in the air gap).**

Adiabatic wall is inserted into the air gap between the two chambers. Both the chambers are filled with water. The temperature of both the chambers is noted with Cr-Al thermocouple. Left chamber was maintained at 70°C. It was observed that there was no appreciable change in the temperature of the right chamber.

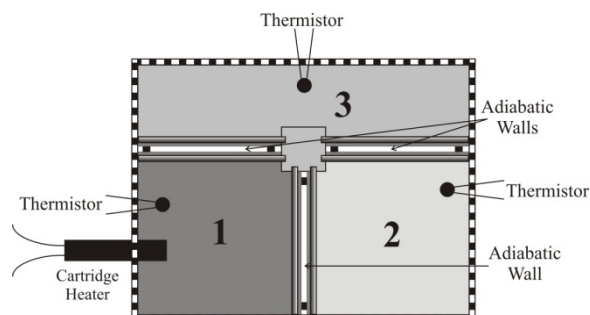


**Figure 5. Apparatus for the thermal equilibrium (Diathermic Wall inserted in the air gap).**

The adiabatic wall is replaced by the diathermic wall. Due to conduction the temperature of the water in the right chamber started increasing and finally attained 70°C.

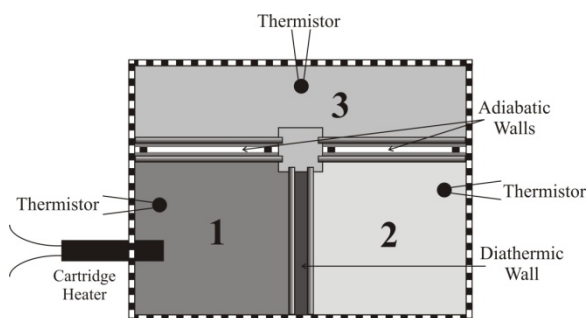
This activity introduces students with the idea of adiabatic wall and diathermic wall. Moreover it also makes them understand about the direction of heat flow i.e. from higher temperature to lower temperature. When the temperature of the both the chambers become equal, the thermal equilibrium is achieved, thus giving students a clear picture of the concept.

### 4.2 Zeroth law of thermodynamics



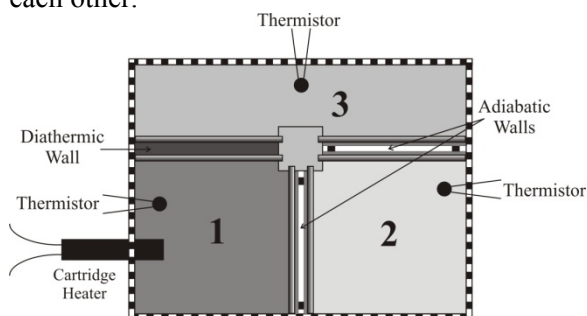
**Figure 6. Apparatus for the zeroth law of thermodynamics (Step 1).**

Step 1: Adiabatic walls are inserted between chambers 1 and 2, between 2 and 3 and between the chambers 1 and 3. Water is poured in all the three chambers. Chamber 1 is maintained at 70°C. No change is found in the temperatures of chambers 2 and 3.



**Figure 7. Apparatus for the zeroth law of thermodynamics (Step 2).**

Step 2: Now replace the adiabatic wall between chambers 1 and 2 by diathermic wall. Slowly the temperature of water in chamber 2 will increase and finally attain 70°C. Thus chamber 1 and 2 are in thermal equilibrium with each other.



**Figure 8. Apparatus for the zeroth law of thermodynamics (Step 3)**

Step 3: Replace the diathermic wall between chamber 1 and 2 by adiabatic wall. Also replace

the adiabatic wall between chamber 1 and 3 by diathermic wall. The temperature of chamber 3 increases, finally becoming equal to the temperature of chamber 1. Thus chamber 1 and 3 are in thermal equilibrium with each other.

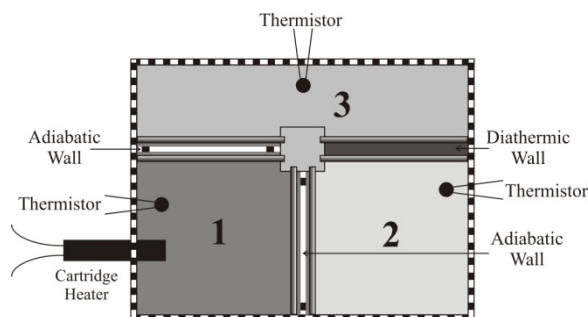


Figure 9. Apparatus for the zeroth law of thermodynamics (Step 4).

Step 4: Now replace the diathermic wall between chamber 1 and 3 by adiabatic wall. Also replace adiabatic wall between chamber 2 and chamber 3 by diathermic wall. It is found that the temperatures of water in chamber 2 and chamber 3 are already equal. Hence chambers 1, 2 and 3 are in thermal equilibrium with each other. Thus establishing the zeroth law of thermodynamics.

## 5. Conclusion

A kit for understanding the concept of thermal equilibrium and zeroth law of thermodynamics was developed. It gives a visual existence of these concepts to the students for better understanding.

## 6. Acknowledgements

We would like to thank Prof. H. C. Pradhan for his useful guidance on these concepts. We would also like to thank colleagues from our institute for valuable suggestions.

## 7. References

1. Dittman R. H., Zemansky M. W., Heat and Thermodynamics, McGraw-Hill International Editions, 1997.
2. Jackson David P., Laws Priscilla W., Syringe thermodynamics: the many uses of a glass syringe, American Journal of Physics, 74 (2006), 94-101.

## A Study of How Participatory Video Can Best Be Used for Developing Spirit of Innovation in Underprivileged Students Studying in High Schools

V.R. Jogi

‘Om-tat-sat’ apartment, 212/50 Rambaug colony, Navi peth, Pune 411030, INDIA

vrjogi@hotmail.com,

vedavati\_jogi@yahoo.com

**Abstract.** Many centuries ago Aristotle had said, ‘What we have to learn, we learn by doing. Unfortunately in typical Indian Education system, which is mainly examination centric, learning Science in school is by rote, the most unscientific way of learning, which may fetch marks but can neither create scientific Temper nor can develop scientific mindset. Situation is worse in rural area as students there are deprived of even basic facilities required for learning subject like Science.

More than anything else what is needed is an appropriate climate for thinking & reasoning faculty to develop for which powerful tool like video can be of great use.

Breaking away from the conventional path of producing video programmes for children with professional support, the researcher has tried to tap the spirit of innovation and creativity in the children themselves to produce video clips that have a direct relevance to their studies. In Swami ivekanad Vidyalaya, in village Asade (District Pune), 2 days’ workshop was conducted on experimental basis in November 2008 for 67 students studying in std. VIII & IX.

They were imparted preliminary lessons in script writing, video-shooting, editing and such other related skills, using different formats like documentary, drama etc.

Students as creative individuals produced video clips on concepts like Force, Pressure, Covalent bond, Acid-Base-Salt etc. with the help of different formats including folk art format.

Effectiveness was judged qualitatively as well as quantitatively.

Students were very receptive to video technology.

2) There was lot of improvement in students as far as communication skills and Science process skills were concerned.

After video production activity change in habits and attitudes has also been marked in students.

The present paper discusses,

The objectives, methodology, observations and inferences that could be drawn from personal observations and the products viz. video clips created by the students which throw light on,

How video being a glamorous medium can give required stimulation to students to study Science subject in school.

How each & every stage of video production process can bring about qualitative change in participating child's personality as a 'student of Science'.

**Keywords:** participatory video media, exploratory method, development of thinking and reasoning faculty, creativity and innovativeness.

---

---

## Prevention of Galvanic Corrosion among Metals

A. Costa-Ramalho, A.R. Almeida-Soares,  
D.A. de Oliveira Pinho  
and J.M. Pereira da Silva

Colégio Internato dos Carvalhos Rua do  
Padrão, 83 – 4415-284 Pedroso Vila Nova de  
Gaia – PORTUGAL

anabela.ramalho@cic.pt; davide.pinho@cic.pt;  
ana.rita@cic.pt; zemanel@cic.pt

**Abstract.** Corrosion is a very important scientific topic concerning both its reaction mechanisms and the economic aspects associated to techniques and corrosive protection procedures. The study of the reaction oxidation-reduction is fundamental for the understanding of the electro-chemical behaviour of metals. We already know that they are reductive, but some are more reductive than others. The idea of an electrochemical potential, in this particular case, metal, is used as an indicator that a metal is exposed to corrosion when its pieces get in contact with their peers. When two pieces of different metals are placed in contact through a conductor, they produce a power- driven force which is attributed to the difference of electrochemical potential existing among the different species. The existence of an electrochemical potential in a system formed by a redox pair, for example a metal board (Mo), sunk into a water solution which contains the ions of that metal, ( $M^{n+}$ ), led to the need to define a pattern of electrochemical potential; so, it was built a table of values, which are scientifically validated according to the equal reactional conditions that were the same for all the studied species. This way the electrochemical potential standard of reduction table was built. The experiment begins with the construction of equipment, simple in its conception and operation, which lets us know the differences of potential among distinct metals. With this information we moved on to experimenting on identifying the cathode and anode areas for the pairs of metals that were being studied. By analyzing the results, we are able to infer which metal can be used in the anodic protection and thus, be 'sacrificed' to corrosion.

---

---

## **Neem Seed Oil: A Greener Alternative For Integrated Pest Management And Malaria Control**

N. Devi and T.K.Maji

Department of Chemical Sciences, Tezpur  
University, Napaam-784028, INDIA  
nimi262002@yahoo.co.in

**Abstract.** Neem is a fascinating tree. On the one hand, it seems to be one of the most promising of all plants and may eventually benefit every person on the planet. Indeed, as foreseen by some scientists, this plant may usher in a new era in pest control, provide millions with inexpensive medicines, cut down the rate of human population growth, and perhaps even reduce erosion, deforestation, and the excessive temperature of an overheated globe. Neem has achieved a relatively wide distribution in the tropical areas of Asia, Africa, South America, and Oceania. In the book "Neem- a tree for solving global problems" the U.S. National Research Council (1992) reported the worldwide distribution of neem trees. It is believed that India has the most neem trees in the world with about 20 million trees. However, China is likely to surpass India soon to be the country with the largest number of neem tree planted. The discovery of neem by western science is attributed to Heinrich Schmutterer, a young German scientist trained in entomology and plant pathology who was working in the Sudan during a locust invasion in 1959. He noticed that neem trees were the only ones remaining green and healthy, while all other vegetation was completely destroyed by the locust plague. Swarms of locusts settled also on neem trees but left without feeding. Schmutterer decided to study this unusual phenomenon. During the following 40 years, he and his students, associates, and scores of scientists throughout the world have learned much about the insecticidal properties of neem products. Indeed, azadirachtin was first isolated based on its exceptional antifeedant activity in the desert locust, and this substance remains the most potent locust antifeedant discovered to date. Promoted in the United States by Robert Larson (with assistance from the U.S. Department of Agriculture), neem rapidly became the modern paradigm for

development of botanical insecticides. Some entomologists now conclude that neem has such remarkable powers for controlling insects that it will usher in a new era in safe, natural pesticides. Extracts from its extremely bitter seeds and leaves may, in fact, be the ideal insecticides: they attack many pestiferous species; they seem to leave people, animals, and beneficial insects unharmed; they are biodegradable; and they appear unlikely to quickly lose their potency to a build up of genetic resistance in the pests. All in all, neem seems likely to provide nontoxic and long-lived replacements for some of today's most suspect synthetic pesticides. Enthusiasm for neem was fostered by several international conferences in the 1980s, 1990s and also in 2000s, and several volumes dedicated to neem and neem insecticides have been published. The 5th and recent World Neem Conference was held at Coimbatore, India in November 21-24, 2007 which had the theme: Neem for a Safe and Healthy World. Neem pesticides have been registered in a number of countries. It seems that the majority of the registered neem pesticides in use around the world are used in USA and India although they are also registered in other countries such as some European countries. In March 2002, there had been at least 40 pesticides containing azadirachtin registered by the U.S. EPA, among which 17 were still in effective registration. Childs et al. reported that there were at least 12 brands of neem pesticides registered in India. Neem-based pesticides refer to those formulated pesticides containing azadirachtin as the major active compound. The present review emphasizes on the potential efficacy of neem seed oil as an effective natural pesticide as well as mosquito repellent and larvicide.

---

---



## Eye and Lens through Millenniums' Prism

S.K. Stafef and M.G. Tomilin

St.-Petersburg University of Information  
Technologies, Mechanics and Optics, St.-  
Petersburg, 197101, Kronverksky Pr. 49,  
RUSSIA  
mgtomilin@mail.ru

**Abstract.** The tied combination of eye and lens has a long history in evolution of science and education. It started at Ancient Egypt and Babylon where the sculpture eyes of pharaohs, idols and secret animals were decorated with crystal lenses for imitation their vivid glance. The first crystal lenses were used as jeweler in combination with secret symbols for magnification it's mighty. Then the ancient priests recognized the effect of lenses optical magnification. The archeologists excavated more than 300 ancient lenses at ruins of first civilization cities. Only Schliemann discovered more than 50 lenses at Troy that opened new scientific direction called archeological optics. The thinkers of Ancient Greece tried to develop the models of vision based on lenses nature. Some poetical myths were devoted to different aspect of such subject. Great Greece scientists developed the basis of optics science including catoptrics and dioptrics. Nero's monocle for vision improvement is still the subject of heated arguments. For solving the problems of myopia the reading stones appeared and were effectively used by monks and nobles.

The achievements of Arabic scientists in theory of vision and ophthalmology, progress of Italian glassmakers led in the Middle Ages to one of the greatest attainment in optics history – to invention of the spectacles: unknown glassmaker in Pisa discovered the magnification properties of glass. Glasses were also being worn in China by this time. The application of spectacles had raised the education level of the peoples of that time. The amazing results were obtained by archeologists in Sweden who excavated at Viking groves crystal quartz lenses with aspherical profile shape.

The next step was made in lenses application to optical observation instruments. The telescope invention by G. Galilee and I. Newton gave a

powerful impulse for astronomy development. The microscope invention by Z. Janssen, R. Hook, A. van Leeuwenhoek and other scientists gave a powerful impulse for biology development. As the result the new universe paradigm had appeared. The technical progress was realized in evolution of camera-obscure, photo cameras, lantern magic, cinema and TV.

The evolution of glasses was continued: B. Franklin in America invented bifocal glasses, A.F. Flick in Swiss invented contact lenses. At now days adaptive lenses based on liquid crystals are starting to replace crystalline lens in eye after cataract ablation.

The tied combination of eye and lens is clearly presented at the new Optical Museum, recently opened at Saint-Petersburg, Russia. The basic principle of the museum is that everybody may touch every exhibit. The program "hands on" is realized on practice. The schoolboys and students can take to pieces the model of eye, both two-dementia in historical context and 3D modern structures. There is a possibility to assemble camera-obscure with pine-hole and also with simple lens and to examine the particularities of image formation. The visitors may receive practice in use of optical microscopes from simplest systems to modern devices including polarizing microscope based on liquid crystal application. It is also possible to make hologram by own hands and to visualize the invisible luminescent images with UV radiation.

---

---

## Challenges in Preventing H1N1 (Swine Flue) in India

K. Surya Rao  
Visakhapatnam-530 008, INDIA  
Kutikuppala@eth.net

**Abstract.** By October 2<sup>nd</sup> 2009 the number of the deaths has shot up to 329 in the country, with thirteen more people succumbing to the deadly virus H1N1. The number of infected people rose to 10,375, with 142 fresh cases detected from across the nation depicting the gravity of the epidemic in INDIA.

### Introduction

2009 H1N1 (referred to as “swine flu” early on) is a new influenza virus causing illness in people. This new virus was first detected in people in the United States in April 2009. This virus is spreading from person-to-person worldwide, probably in much the same way that regular seasonal influenza viruses spread. On June 11, 2009, the World Health Organization (WHO) signaled that a pandemic of 2009 H1N1 flu was underway.

The flu is a contagious virus that spreads from one person to another through tiny droplets that are released into the air when a person infected with the flu coughs or sneezes. Sometimes, people can become infected by touching their nose or mouth after touching something infected by the flu virus.

Most healthy adults can infect others one day before they begin experiencing symptoms and up to five days after they become sick. That means one can pass on the flu to someone else before he/she knows or sick. A typical case of the flu can last up to one week. The flu can be a serious illness, particularly for mature populations aged 50 and older, and those with chronic illnesses such as diabetes, heart disease, and asthma. .

### Prevention

Cover the nose and mouth with a tissue during cough or sneeze. Throw the tissue in the trash after use. Wash hands often with soap and water. Avoid touching your eyes, nose or mouth. Germs spread this way. Try to avoid close contact with sick people. If sick with flu-like

illness, keep away from others as much as possible to keep from making others sick.

There is no vaccine available right now to protect against 2009 H1N1 virus in India... However, a 2009 H1N1 vaccine is currently in production and may be ready for the public shortly. The first round of swine flu vaccines, was administered to health care workers in Indiana and Tennessee, the U.S. Centers for Disease Control and Prevention (CDC) has revealed. So, the Indian Government may place an order with the US government for the vaccine. Mean while many companies in India have applied to the government for license to manufacture indigenousness H1N1 Vaccine.

In countries other than Mexico with confirmed outbreaks, the H1N1 flu strain has caused mainly minor symptoms. However, epidemiologists are warning it could be especially dangerous to people already fighting other infections like HIV or TB.

### Challenges

India being a country with superstitions illiteracy ignorance and complacency posing a great threat for the preventive measures. Basing on the attitude cultural values and the response of our people we have to design newer strategies to effectively control H1N1 flue in the country before it mutates and pose fresh challenges.

---

---

## Electro-Kinetic Phenomena Kit

D. Valeriu, Z. Florin and B. Gheorghe  
Angelescu College, 17 Crizantemelor Street,  
Buzau, ROMANIA  
dumitrescuprof@yahoo.com,  
florindrum@yahoo.com

**Abstract.** Because of its size and complexity, the kit allows the study, regardless of the conditions, of the electrical charges through matter, in its three most common forms, being able to isolate a large number of effects that take place when electrical charges are present. Example of functions: - Electrical pile with a salt bridge on filter paper - Electrical piles without a salt bridge - Photovoltaic cell with cupric oxide - Electrolysis of watery solutions - Electrolysis of the NA sulphate solution with an iron anode - The human pile With the help of this kit we may give hands-on examples of a number of electro-chemical phenomena. It allows us, along a summary theoretical study experimental conditions that are very similar to those found in an expensive laboratory. Because of the availability of the materials that compose it, the kit proved to be a success, as a real help for teachers.

---

---

## Science for Common Mass: Thoughts and Activities of Tagore

M. Mishra  
Ekamra College, Bhubaneswar, INDIA

**Abstract.** Rabindra Nath Tagore was a versatile genius. Apart from his creative literature, painting, philosophical writings and thoughts on education he had a keen interest on popularization of science and promotion of scientific temper in the society. In the last phase of his life he had written a book in his mother tongue Bengali entitled 'Biswa Parichya' (An introduction to Universe). The main objective of writing this book was not to discuss development of scientific research but to foster scientific knowledge among the common public through their mother tongue. In fact, dedicating the book to Satyendra Nath Bose, the famous physicist, he expressed his desire that every common man should have right to enter in the corridor of

science though not in the inner house. Inspired by Tagore many noted scientists like J.C Bose, S.N Bose, M. N Saha, P.C Roy etc had written a good number of books and articles in their native language for common mass.

Through out his life Tagore had experienced that the Science establishes the affinity between human life and natural universe. He nurtured this philosophy in many of his writings and fosters this idea through introduction of various festivals in his institution at Santiniketan. Agriculture, environmental protection, medicinal value of the plants, eradication of superstitions and social dogma, campaign of scientific humanism by glorifying human over the Divine and encouraging the power of reasoning over blind believes-all these important areas of science and scientific temper have been treated with utmost care in his thoughts and practices.

The present paper aims to review all these aspects with careful analysis of his works and useful references to establish Tagorian experience in Science for all.

---

---

## Ecological Niches as Learning Resources

L. D'Cruz  
Department of Biology, St. Xavier's College,  
Ahmedabad 380 009, Gujarat, INDIA  
lancy\_dcruz@hotmail.com

**Abstract.** About 15 years ago, St. Xavier's College, initiated a process of setting up a series of 'Ecological Niches' on its 24 acre sprawling campus, located in the heart of urban Ahmedabad. These biodiversity rich enclaves, presently housing over 800 species of plants, also attract a diversity of faunal life and are used as a living laboratory for the biological sciences.

The Ecological Niches provide invaluable learning resources for students of Botany, especially for studies related to Taxonomy, Ethnobotany and Ecology. They also provide materials for phytochemical and biochemical studies by Biochemistry students and a ready source of raw materials for the Biotechnology students for plant tissue culture. The Bio resources have been accessed by students of the Arts faculty who did a study of the "Plants in the writings of Kalidasa".

Several species of ethnomedicinally significant plants (used by the Vasava tribals) have been introduced into these niches from the Dediapada forests, situated 230 kms from Ahmedabad. Three interactive workshops have been held involving tribal medicine men from Dediapada who visited the Campus and shared their traditional wisdom with the undergraduate students of the College.

The biodiversity rich niches are used as learning resources for Tarumitra, the College's Environment Group. Tree walks, and nature sensitization sessions are held for school students and for nature lovers. The nurseries, lawns and green houses serve as the practical laboratories for the Career Oriented Course on "Gardening and landscaping" offered to the students of the College.

Above all, the Ecological Niches provide the over 2,500 graduate students the rare opportunity of growing up as eco-sensitive citizens in a green, biodiversity-rich environment.

acids and cyanides. Every college student can't land on the Moon to explore water and life there nor can they climb up to the Everest to discover new bacteria species. No one can dare to try hands-on "what happens when a person touches a high tension wire". Every layman can't try hands-on launching rockets or developing transgenic creatures. Therefore, hands-on science learning has its own limitations. Here, communication through multimedia simulations and ICT tools can be a lucrative alternative. Such modules can show some people trying their hands-on science while making all the viewers to identify with the actors and virtually feel 'hands-on science'. A scientific analysis of hands-on communication of science will be presented in the paper and the results will be discussed in comparison with other studies made in the area.

---

---

---

---

## **Hands-on Science: Communication through Multi-media and ICT Tools**

A.S.D. Rajput

VPO Pargwal, Teh. Akhnoor, Distt. Jammu,  
INDIA

abhaysdr@yahoo.co.in

**Abstract.** Hands-on science can be the best way to learn about science, because it is learning through doing by one's own hands. Experimenting and doing activities offer first hand knowledge leading to innovations and new discoveries and inventions. In fact, human science evolved through experimenting and doing, sometimes hit and trial method. Before the theory of science came into existence, man tried his hands on nature consciously or unconsciously. Such a doing resulted in knowledge creation about nature – science. Learning about nature by activities and personal involvement is undoubtedly the first line mechanism creating or acquiring knowledge of science. As it may not be possible for everyone to have a good lab at one's home and to do all the experiments. Every secondary school student can't do all reactions of mercury, lead, strong

## Transformation of Seed Oils into Polyurethaneamide Protective Materials

M. Kashif, F. Zafar and S. Ahmad  
Materials Research Laboratory, Department  
of Chemistry, Jamia Millia Islamia,  
New Delhi-110025, INDIA  
kashif\_jmi25@yahoo.co.in.;  
fahm\_zafar@yahoo.com; and  
sharifahmad\_jmi@yahoo.co.in

**Abstract.** Seed oils attract considerable attention in the development of polymers for protective coatings materials due to environmental concern as well as depletion of petroleum feed stocks. The oil based polymers such as epoxies, polyesteramides, alkyds, polyetheramides, polyurethanes, etc have been synthesized as an alternative of petro-based polymers that found application in the field of protective coating materials. Seed oil, a triglyceride having number of functionality that can be utilize in versatile field.

Transformation of seed oils (bioresource) into polyurethaneamides [PUAs] protective materials is a process of different chemical reactions. The synthesis reaction is carried out in two steps; 1<sup>st</sup> step is amination of seed oils that results N, N-bis (2-hydroxyethyl) fatty amides [DFA], and 2<sup>nd</sup> step is urethanation of DFA in minimal possible organic solvent. FT-IR, <sup>1</sup>H-NMR and <sup>13</sup>C-NMR spectral studies confirm the structure of PUA. The physico-mechanical and chemical resistance performance were investigated by the standard laboratory methods. TGA technique was used to determine the thermal stability of PUA. It is observed that PUAs shows potential for its application as eco-friendly, protective polymeric coating materials.

---

---

## Generating Electric Power through Wind Mills in Motor Vehicles HSci

G.P. Kumar, R. Muthukumar, R.  
Kalaiyarasi, S. Lakshmanan, S. Venkatesan  
and A. Manikandan  
Panchayat Union Middle school,  
Vembanpatti – PO, Gandarvakkottai (Tk),  
Pudukkottai (Dt), Tamil nadu State, INDIA  
mani\_tnigt@yahoo.co.in,  
mani.tnigt@gmail.com

**Abstract.** Fuel is the main source to fulfil the basic needs and urgent needs in the globe. Using the fuels electricity is generated there is machine and no work without electricity. Generating electricity using the wind energy is safe and economical, renewable and accepted by all walks of life. Electricity can be generated by rotating the wings and using the wind energy. This kind of wind mills electricity is possible when the wind is so heavy. When we install the small wind mills on the roof of motor vehicles we can generate and save electric power in this method. If we follow this method in all vehicles we can save fuel and avoid economical wastage. We can avoid the problem of wastage threatening the world. Based on this report if we do more research on this field, we can fulfil the required electricity, changing all vehicles as power station, generating electricity to the usage. There is no doubt about it.

---

---

## **EUREKA! – Experimental Science Sessions in Primary Schools**

J. Saiote, L. Carvalho, N. Ribeiro and F.  
Santos-Silva

IPATIMUP –Rua Dr. Roberto Frias s/n.  
4200-465 Porto. PORTUGAL.

jsaiote@ipatimup.pt, luiss@ipatimup.pt,  
nribeiro@ipatimup.pt, fsilva@ipatimup.pt

**Abstract.** The recent evolution and globalization of knowledge have brought considerable challenges to the development of new educational models that enable an effective progress of scientific and technological literacy. The society no longer asks for a mere reproduction of knowledge but demands innovation, creativity and new ways of thinking. Integration of experimental science teaching in the curricula should thus be a priority, even for early age students.

“Eureka!” project present a new approach to experimental science teaching with a strong emphasis on a direct intervention in primary schools.

The project has being implement for 2 years (200 sessions) in a population of 1200 students (ages 5 to 10 years) in 14 primary schools of northern Portugal. Throughout the school year, each class has several experimental sessions, properly adjusted to the students’ age and complementary to the school curricula. In each session, two instructors from IPATIMUP carry out a series of experimental activities in the classrooms with the cooperation of the schools teachers. The presence of three educators, allows the partition of the class in small working groups that facilitates an active involvement of the students in the experimental activities. Each activity is complemented by a support document that is essential to the completion of the experimental activity and fulfils a double role as experimental protocol and data record sheet. The simple structure and attractive illustrations of these materials work very successfully even for young learners. The experimental activities and pedagogic support documents were developed by a team of experts (science teachers, investigators, designers) and were conceived to foster student’s scientific attitude namely the skills of observation, logic thinking, critical analysis and collaborative communication. The presentation

of several experimental sessions throughout the year creates in the students a positive routine, reducing the novelty factor that can disturb their attention and allowing them to be more focused on the experimental activities. The majority of the sessions are based upon the model POE (predict – observe – explain). The students are confronted with a problem and an experimental procedure to answer it. After the completion of the experimental procedure the students confront the observed results, compare them with the predicted ones and advance an explanation. Through this model it is possible to engage students physically (“hands-on”) and mentally (“minds-on”) in the experimental activity, which contributes to a better understanding of the scientific concepts of the session. This is an on-going project, closely monitored so that it can be assessed their real impact on the students performances in scientific areas.

---

---

## Science Popularization through School Education: The Role of Teachers and School

P. Kumar<sup>1</sup> and P. Singh<sup>2</sup>

<sup>1</sup>Govt. Inter. College, Bhojpur, Moradabad,  
INDIA

<sup>2</sup>Govt. Inter. College Moradabad, INDIA

**Abstract.** The present era is of science and technology. Scientifically aware individuals make a learned society which in turn makes a nation progressive, but there are still some gaps between the sciences and their understanding by masses. So it is needed to make everyone aware about the science in our daily life.

Science communication and popularization activities can promote the scientific awareness among the people and inculcate scientific temper. Spreading the scientific awareness at school level in children through science popularization activities can be a good move towards achieving this goal, as children hold the key for future.

Teachers can play a pivotal role in these science education programs. The present paper is concerned with the mindset of teachers today, problems in schools and necessary steps towards the science popularization activities.

---

---

## Lectures Plan on Recording Media Based on LC materials: a Workshop

M.G. Tomilin

St.-Petersburg University of Information  
Technologies, Mechanics and Optics, St.-  
Petersburg, 197101, Kronverksky Pr. 49,  
RUSSIA  
mgtomilin@mail.ru

### 1. Introduction

Main applications of LC materials are displays, photonics devices and recording media. Recording media based on LC materials has unique properties in comparison with traditional recording media.

### 2. Structures and main properties of LC materials

(LC condition of matter, phase classification, structures and textures, defects). Chemical structures of LCMs (components and mixtures for recording media) and their correlations with operation parameters.

Physical properties of LCMs and their correlations with operation parameters (order parameter, temperature range, thermodynamic, optical, electrical, magnetic, viscous and elastic characteristics, surface tension). Anisotropy of LCMs' physical properties is the main basis for applications.

### 3. Optical (electro-optical) effects in LCs.

LC electro-optical cell and the problem of molecules orientation (main methods). Optically addressed spatial light modulators. Electro-optical effects in NLCs (polarization and light scattering effects). *Polarization* (orientation) effects: tunable birefringence, guest-host effect, twist and super-twist and their modifications, flex and light induced effects. *Scattering* effects: dynamic scattering modes in NLCs and SmA. Optical effects in PDLC. Magneto-optical and thermo-optical effects. Effects in ChLCs (Ch-N phase transition, helicoids untwisting); SmLCs (Fredericks transitions, dynamic scattering) and Sm\*LCs (Clark-Lagerwall effect, helicoids deformation, electroclinic effect, etc).

### 4. Recording media

Thermo detecting on ChLCs in medicine, aerodynamic experiments, detecting of the laser

pulses structure, IR and other radiations, control of microelectronics elements quality. Dynamic holographic systems for optical aberrations and atmospheric turbulence compensation. Photosensitive Polymer LCs for recording laser beam information in real time and with memory. LC vision on NLCs for detecting the structure inhomogeneities on material surfaces (in optical technology, medicine and biology), the distribution of invisible low power physical fields and microrelief defects.

---

---

## Portable Solar Water Purifier

D. Siri, and N.A. Narasimham  
Z.P.High School, Ramatheertham,  
Nellimarla Mandal, Vizianagaram Dt.,  
INDIA  
likhita1960@gmail.com

**Abstract.** Obtaining clean drinking water is a constant challenge in many countries. Often the only water available is rife with disease-causing bacteria, and must be disinfected to make it safe. Conventional methods for disinfecting drinking water, including boiling and adding chlorine compounds, can be time-consuming and expensive. In some regions, it is difficult to ensure a reliable supply of chlorine, which can also give the water an unpleasant taste. In many areas, there is little fuel available for boiling water. Drawing inspiration from water treatment practices developed in India as long ago as 2000 B.C., researchers at the American University of Beirut in Lebanon developed, with IDRC support, a low-cost, practical means to provide safe drinking water in rural and urban areas in developing countries. The key to this method lies in the ability of direct sunlight to destroy bacteria. The treated water is suitable for drinking, and can also be used to prepare Oral Re-hydration Therapy (ORT) solutions to treat dehydration suffered by children with diarrhea. Solar radiation is a form of renewable energy that is abundant and accessible in most southern countries. The research focused on small quantities of drinking water, sufficient to satisfy the daily requirements of a small family. Sunlight with wavelengths of 315-400 nanometers (nm) on the ultraviolet (UV) range of the electromagnetic spectrum is most effective at

destroying bacteria. Since colourless glass or plastic can transmit light in this near ultraviolet range, they are the best materials for disinfection. Visible light (400-750 nm) next in terms of efficiency, with the visible band of violet and blue light (400-490 nm) is the most useful within this range. As a result, violet, blue, and very light green-tinted glass follow colourless glass or plastic in order of suitability.

### Main objectives of the project

To provide safe drinking water for poor and needy • To educate the rural people about the diseases and the causatives • To educate people about the bacteria and to make them aware of them.

### Methodology

By filling a polyethylene bottle with contaminated water and leaving it in bright sunlight, it is treated through three synergistic radiation mechanisms • Infrared heating the water. If the water temperatures raises above 50°C, the disinfection process is three times faster. • Along with normal filtration of water disinfection using Sunlight and UV light • To make the apparatus portable and easy to use. • To enable even poorer community also can afford to possess one of such water purifier.

### Analysis

The efficiency of the purification depends on the physical condition of the plastic bottles. Heavily scratched or old, blind bottles should be replaced. If the sunlight is less strong due to overcast weather or a less sunny climate, a longer time in the sun is necessary. Recommended Time for disinfection Weather Conditions Minimum Duration sunny 6 hours 50% cloudy 6 hours 100% cloudy 2 days continuous rainfall unsatisfactory performance,

### Conclusion, significance and problem solving

If the water bottles are not left in the sun for the proper length of time, the water may not be safe to drink and could cause illness. Some glass or PVC container materials may prevent ultraviolet light from reaching the water Concerns about the general use of PET-bottles



were also expressed after a report published by researchers from the University of Heidelberg on antimony being released from PET-bottles for soft drinks and mineral water stored over several months in supermarkets. This project is valuable for treating water where fuel or cookers are unavailable or prohibitively expensive. Even where fuel is available, however, this is a more economical and environmentally friendly option. The product will be useful and significantly satisfactory at locations where the day time temperatures will be around 40-49 degrees. Normally in our area people work in Agricultural fields all the day long and there will be not much shade and hence if there this process is much useful. In general people who were traveling with duties that are compulsory and for their earning bread they need safe drinking water without bacteria hence this product is helpful for them. The cost of the product will be much low and easily reachable to even poor and if the Government encourages the product and supplies at much reduced price the poor will be get benefited.

---

---

## A Case Studies of the Listeners Profile of Radio Science Serial

R.S. Yadav

**Abstract.** The three parameters of radio broadcast are education, information, and entertainment, which have been well enshrined in the motto of All India Radio, “**Sarva Jan Hitaya, and Bahujan Sukhaya**”. AIR had started regular broadcast of popular science programmes from its major stations in mid seventy or early eighty. The mega science serial, “**Manav Ka Vikas (The Human Evolution)**” was a great milestone in science broadcast, during early ninty. After a gap of one decade a series of new Science Serials were aired on National or Regional network of AIR. Based on listener’s feedback in response to different episodes, the records of listener’s profiles have been maintained and prepared by AIR Delhi station.

The profiles of listeners in response to new science serial, “**Sitaron Se Aage**” and “**Beyond the Stars**”(based on International Year of Astronomy) show that the highest listnership is

in the rural and remote areas which is 64.19% followed by semi-urban areas and then in big cities (3.05%). The feedback from Senior Secondary level students is highest (47.28%) followed by Graduate and College level students (33.67%), primary and middle pass (11.24%) and Post Graduate (7.81%).

Occupation and profession wise, the highest interest in Astronomy based programmes has been found among students (55.21%) followed by farmers and farm labours (55.21%), businessmen (15.1%) and teachers (9.38). Age wise breakup show maximum feedback from youth (20 to35 years) followed by children (up to 20years) middle age group (35 to 60years) and senior citizens(>60 years). It is also noticed that about 11.48% listeners are associated with **Science Clubs** and **Vipnet Clubs** and 7.33% are from dedicated **Radio Listener’s Clubs** and 82.19% are independent listeners.

Comparative profiles studies of Astronomy based serial with our earlier science serial, “**Jeevan Ek Roop Aanek**”(broadcast in 2003) shows that central theme, contents of the programme, No. of interactive programmes etc. play an important role in defining the listener’s profiles. The study shows that even hardcore science if presented in simple and interesting formats of feature, documentary, drama or docu-drama with regular interactive programmes is easily acceptable and well understood by a substantial portion of our society.

---

---

## 'Nahar' (Mesua ferrea) Seed-as A Source of Fuel

B.B. Borah<sup>1</sup>, D. Borah<sup>1</sup> and G. Sarma<sup>2</sup>

<sup>1</sup>Sankardev Sishu Niketan, Dhekiajuli, P.O.  
– Dhekiajuli-784110, Assam, INDIA

<sup>2</sup>Dhekiajuli High Schools, P.O. – Dhekiajuli-  
784110, Assam, INDIA,  
bedantabikram@yahoo.co.in,

sarmah\_ganesh@rediffmail.com

**Abstract.** Today, the earth has attained almost the climax of civilization but at the cost of the natural resources and the environment. Development takes place at the cost of energy particularly the fossil fuel. In the backdrop of diminishing fossil fuel reserve, the quest for nonconventional energy sources is the agenda for the future.

'Nahar' (Mesua ferrea) known as Indian Iron wood is an oil bearing tree which contains 75% oil in its kernel. In this project, it is attempted to explore the possibilities of using 'Nahar' Seed as a source of fuel. An experiment was undertaken to extract the oil and use it as fuel for lighting in houses.

500 gm. Seed was crushed in home grinder and obtained 310 ml oil by pressing the material through muslin cloth. The oil was used for lighting lamps. The flame burnt brightly but could not sustain for long probably due to high viscosity of the oil. 'Nahar' oil was mixed in different proportion with Kerosene and found encouraging results while burning as lamp. 10% 'Nahar' oil blended Kerosene gave the brighter flame with less smoke. After obtaining success in mixing with Kerosene for lighting lamp, we made further study in two main aspects:-

1).Quantity of smoke/Carbon emission and comparison of smoke point.

2). Cost benefits analysis in present level Kerosene consumption for domestic purpose.

In our survey, we found that total monthly consumption of Kerosene in Dhekiajuli Revenue Circle is 240000 lit. In a rough estimate 20% (approx.50000 lit) is used to run Generators and Irrigation pump sets and around 190000 lit. is assumed to be used in domestic lighting and cooking purpose. It was found in 5 minutes, 1ml of 10% 'Nahar' blended Kerosene produced 0.05 gm carbon while 2ml of 100% Kerosene

produced 0.1 gm carbon. This amounts to 9500 kg Carbon emission per month to the atmosphere in the Dhekiajuli Revenue Circle area. By using 10% 'Nahar' blended Kerosene the Carbon emission per month to the atmosphere could be reduced to 50% i.e. 4750 kg per month. The smoke point apparatus showed 24mm reading in 100% Kerosene and 29mm reading in 10% 'Nahar' blended Kerosene, giving a larger flame size and brighter light. The present monthly consumption of Kerosene in Dhekiajuli Revenue Circle is of 240000 lit. If the Kerosene is blended with 10% 'Nahar' oil, nearly 50% Kerosene will be sufficient to illuminate household for the same period, with a saving of Rs. 1339500/- per month. Further while saving 104500 lit. Kerosene per month, Rs. 1463000/- will be saved by way of saving in Govt. Subsidy at Rs. 14/- per lit. We have found the production cost of 'Nahar' oil is Rs. 13/- per lit. in our study. The study showed that 'Nahar' blended Kerosene keep the surrounding comparatively smoke free and give economic benefit to the extent of 50% less consumption in Kerosene. The commercial cultivation of "Nahar" may provide valuable Bio-fuel. It may also provide timber, firewood and add aesthetic value to the nature. The blooming season will also support Bee-keeping industry. The need of the hour is to frame a scientific policy to further the interest in bio-fuel use and cultivation.

---

---

---

## Catalyzing science communication through students

M.K. Jolly  
Indian Institute of Technology Kanpur-  
208016, INDIA  
mkjolly.15@gmail.com

**Abstract:** Invariably, owing to various societal pressures and lack of science communication, we see a lion's share of students from pioneer science and engineering institutes end up in finance or run another rat race for CAT. We tried an experiment- NERD (Notes on Engineering Research and Development) - an exciting student led initiative of a quarterly science and technology magazine at IIT Kanpur, with focus on content created by students- be it their research work or their interest in one or the other scientific/technical field. It was received overwhelmingly by students as well as faculty members. We are now planning how similar initiatives can be effectively utilized for science communication, not only in India, but also forming a network globally.

**Keywords:** science communication, NERD.

### 1. Introduction

Many students from the usual engineering or science stream go into careers light years away just after their undergraduate degrees, and elite technical institutes like IITs are no exception to this trend. It is a well established and known fact that IITs attract the cream of the country, but a plethora of reasons from our social fabric cause this shuffling of priorities, due to which a steady growth lucrative job or an IIM call becomes the ultimate goal of students' lives, just as it was clearing JEE (Joint Entrance Examination) a few days ago. Lack of science communication among students as well as faculty aggravates the situation. There is a dire dearth of motivation to contribute to technical growth.

The Interim Report of the fifth Academic Review Committee of IIT Kanpur says, "Consequently, the highly "technical" IIT education becomes secondary, which, in turn, leads to motivational deficit and a lack of intellectual curiosity. With such a mindset, the IIT experience is akin to a black box; the

students use IIT to increase their employability without imbibing the essence and wholesomeness of IIT education." [1] Dr. C. V. R. Murthy (Distinguished Teacher Award 2008, IIT Kanpur) opines, "Today's student entering IIT is burnt out; he/she is not excited about working hard again to build a technical base. Parents look at joining their children in IITs as a business venture for trading large dowry or getting large salary. Such decisions to join IITs are faulty. IITs are advanced technical institutes for technology education in the country, so that the graduates will address the technological needs of the country. Thus, the spirit of an IIT student should be to gather advanced knowledge in technology; any other purpose defeats the very existence of these institutes." [2]

Out of the sample set of 10 undergraduate students across all departments in their final and pre-final years, none of them could name 3 laboratories under CSIR, two of them had a vague idea about what CSIR does, and only one knew what does acronym CSIR stand for. Can you get a picture of India 2020 vision of Dr. Kalam? It was with the vision of providing a forum for the exchange of ideas and open dialogue among students on contemporary issues of science and technology, publicizing the work done by students and available research opportunities to inspire other students in science and technology, and improve students' attitude towards research and technical careers, that we started an experiment named NERD (Notes on Engineering Research and Development) - a campus science and technology magazine of students, by students and for everyone. [3]

### 2. Experiment

NERD magazine is an exciting, student-led initiative aiming to broaden the scope of scientific experience of students. It provides opportunities to students for participate in public understanding of science, where students write articles in a language comprehensible by non-experts of the field. The magazine focuses not only on original research work being carried out by students, but also articles on interest based scientific literature, and experiences based on their summer projects and internships, hobby-projects and conferences form an integral part. Interviews with eminent scientists to inspire the student audience, articles related to innovative

teaching and interesting experiments, and proposals for implementing new ideas/initiatives can also be found inside NERD. Book reviews, puzzles, questions based on daily life experiences whose answers are not so seemingly simple, cartoons etc. take utmost care to differentiate NERD from a journal. Figure 1 tells why NERD was started.

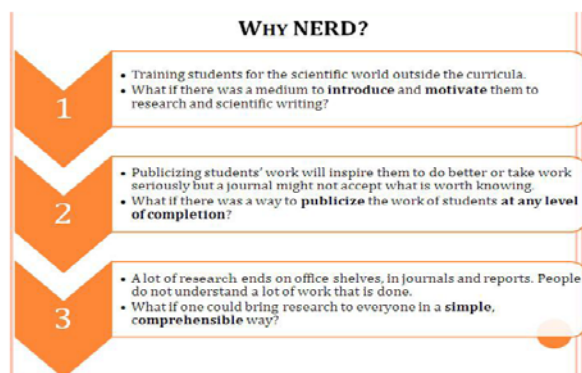


Figure 1: Why was NERD started?

NERD started when Dr. K. Muralidhar (Dean, Research and Development, IIT Kanpur) welcomed and encouraged our proposal to start such a publication. It started as a project under Dean, Research and Development, IIT Kanpur, with a strong network of faculty members across all departments on our review board, senior research scholars on our editorial board, and a strong team of undergraduate students handling content management and publication process. [6] We published 4 issues and 2 promotional issues in a year. The inaugural issue was launched during Teachers' Day function on September 5, 2008 and the special issue themed 'Energy and Environment' was launched in the opening ceremony of Techkriti'09, the national annual technical festival of IIT Kanpur by the Chief Guest, Dr. David Morrison (Director, NASA Lunar Science Institute). [5] We also interviewed faculty members known for their pedagogical techniques among students- Dr. H.C. Verma (Author, 'Concepts of Physics'), Dr. A.K. Mallik (faculty in mechanical engineering department, IIT Kanpur since 1978) and Dr. C.V.R. Murty.

We also impressed upon students the importance of good communication skills, both technical and non-technical, since they are future members of the scientific community. Workshops like 'Stepping Stones' where participating students are given research papers of some particular fields and they are asked to

communicate it to the audience consisting of first year undergraduates to senior research scholars, are also being conducted where audience gives suggestions and marks to each participant. Sessions for making interview questionnaire for scientists, so that the interview bears more of a pedagogical tinge, have also been conducted. Popular talks by Dr. Pradeep Srivastava on Sciotoons and this novel way of science communication and by Dr. Manoj Patariya (President, Indian Science Writers' Association) on current status of science communication in India were also organized.

### 3. Results and Discussion

NERD received an unexpectedly great response from students as well as faculty members throughout. Comments as "NERD is something that was long overdue.", "This is shaping into a useful resource for IITK community.", "In times when 'financial engineering' has taken over real science and engineering, it is refreshing to see your endeavor.", and "It is specially heartening to see the first serious student-inspired initiative on R&D" were received by faculty members from various departments.

We never thought this change would be so welcome, but our novel idea and diligent hard work proved us wrong. We now look forward to form a network of all budding engineers and scientists across the nation, and involve them in alternative ways of communicating science among students and then among masses. The phenomenon of drifting towards lucrative offers shall change only when scientific research all over the country gets encompassed, the gap between various institutes is reduced and a nationwide research foundation is formed, and students are motivated to pursue engineering or sciences related careers.

To quote the IIT review Committee 2004: "The world has transited from industrial revolution and from industrial economy to knowledge revolution and knowledge economy." It adds further that the new challenges on the floor 'are indeed the kind suited to India's genius...**The nature of products of immeasurable economic worth will henceforth be knowledge based, requiring minimal capital unlike the conventionally manufactured industrial products that guzzle huge capital.**

*Here is where the IITs must have their prominent presence”*. We believe that NERD is a step fully in line with this, and that IIT Kanpur is the place where this step should be taken. Let us chase the road towards the goal of better science journalism and communication in India, and catalyze this process by involving students, not only from engineering institutes, but also journalism courses.

#### 4. Acknowledgements

I acknowledge the support, guidance and faith we enjoyed with Dr. Muralidhar as the Dean, R&D. Dr. Harbola, the faculty project coordinator for NERD, also guided the amateur undergraduate team to get and select good articles. Thanks are due to Arvind Kothari, who wrote the first draft of proposal for NERD, and all founding members of NERD, who stayed along to make it happen along with me.

#### 5. References

- [1] [http://web.iitk.ac.in/doaa/ARC/Interim\\_Report13Sep2009.pdf](http://web.iitk.ac.in/doaa/ARC/Interim_Report13Sep2009.pdf)
  - [2] [www.nerdmag.org/noah](http://www.nerdmag.org/noah)
  - [3] [www.iitk.ac.in/nerd](http://www.iitk.ac.in/nerd)
  - [4] <http://students.iitk.ac.in/snt/takneek>
  - [5] [www.techkriti.org](http://www.techkriti.org)
  - [6] [www.iitk.ac.in/dord](http://www.iitk.ac.in/dord)
- 
- 

## The Production and Analysis of the Teaching Tool for Showing Spherical Magnetic Field by Ferrofluid

F.U. Yan-Qing<sup>1</sup>, S.U.N. Qiao<sup>2</sup>, L.I.U. Zhi-Sheng<sup>1</sup> and L.I. Xue-Hui<sup>1\*</sup>

<sup>1</sup>College of Physical Science and  
Technology, Dalian University, Dalian  
116622, CHINA

<sup>2</sup>Civil and Architecture College, Dalian  
University, Dalian 116622, CHINA  
[dltu.lixuehui@gmail.com](mailto:dltu.lixuehui@gmail.com)

**Abstract:** Based on the special shape change of ferrofluid in the extra magnetic field, this paper uses self-produced ferrofluid to develop a teaching tool “Three-dimensional dynamic ball” to revealing the magnetic field. The ball can show spatial distribution of magnetic field vividly, thus stimulating students’ passion of learning interrelated science and technology knowledge.

**Keywords:** magnetic field; ferrofluid; three-dimensional dynamic display.

#### 1 Introduction

As is known to all, there is something invisible, intangible around the magnetic body, but it actually exists, which we termed “magnetic field”. Traditionally, the existence and strength of the magnetic field had been proved by putting some needles and iron fillings around the magnetic body (Fig.1), the needles will deflect, and the iron fillings will show a regular distribution. However, the deflection of needles can’t reflect the overall spatial distribution of the magnetic field, and the regular distribution of iron fillings can show the whole magnetic field on two-dimensional static display merely. All in

---

\* Funded by National Natural Science Foundation (50677005) and Dalian University Undergraduate Creative Education Foundation (081201A).

Author: Fu Yanqing, Undergraduate, Student head of “Workshop of Research and Development of Nano-ferrofluid”.

Corresponding author: Li Xuehui, Professor, Doctoral tutor, Research physics experiments/nano-ferrofluid materials. 0411—87402712,.

all, the traditional methods can't demonstrate three-dimensional spatial distribution of the magnetic field effectively and dynamically. Hence, this paper developed a novel kind of teaching tool—Three-dimensional dynamic ball—to revealing the magnetic field vividly.

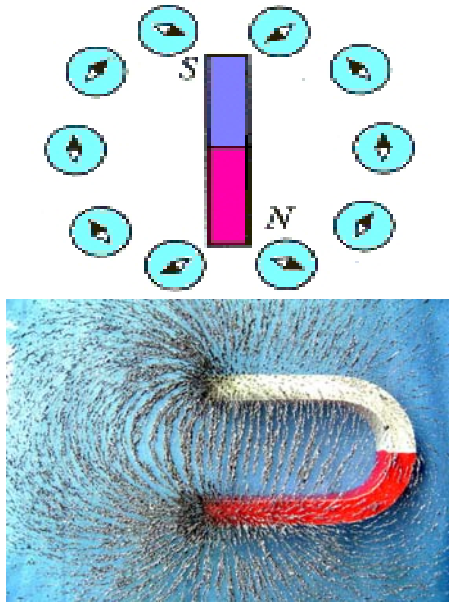


Fig. 1. Traditional methods to show magnetic field.

Ferrofluid can show the spatial distribution of the magnetic field because of its special composition (Fig.2): nano-magnetic particles, surfactant and carrier fluid. Under the condition of an external magnetic field, ferrofluid can produce unique spatial distribution along the magnetic field lines, which is influenced by gravity, surface tension and magnetic force, thus interfacial instability occurs and three-dimensional spikes generate (Fig.2). These spatial distributions of the three-dimensional peaks also reflect the spatial distribution of the magnetic field.

## 2 Three-dimensional dynamic ball for revealing magnetic field

### 2.1 Structure and features

The three-dimensional dynamic ball is mainly for showing the spatial distribution of the magnetic field of spherical permeable body. It consists of ferrofluid, transparent liquid, spherical permeable body, glass container and base. The transparent liquid and the spherical permeable body are sealed in the glass container.

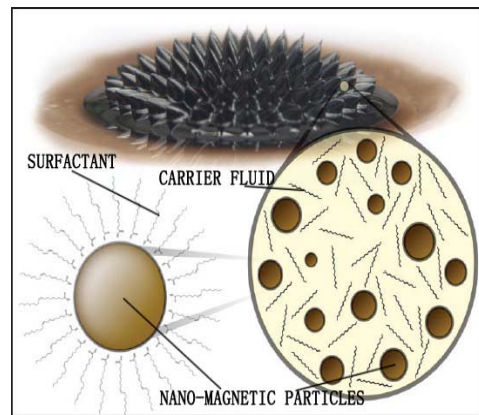


Fig. 2. Schematic diagram of ferrofluid and three-dimensional peak phenomenon.

The transparent liquid can avoid the phenomenon of ferrofluid capillarity. Due to capillarity, ferrofluid can adhere to the inner walls of the glass container easily, leading to an ambiguity phenomenon of showing the spatial distribution of the magnetic field. After several tests, this paper figures out the production methods of the transparent liquid. The addition of the transparent liquid prevents the phenomenon of ferrofluid capillarity effectively.

### 2.2 Display process and phenomena

The teaching tool can show the spatial distribution of the magnetic field of spherical permeable body in the conditions of permanent magnet and electromagnet. Users can hold the base with the left hand, the permanent magnet with the right hand. Adjusting the relative spatial position of the base and the permanent magnet by the two hands, users can observe the spatial distribution of the magnetic field. If users change the permanent magnet with an electromagnet, they just need to place the permeable material of the base on the upper surface of the electromagnet coaxially, and then change the exciting current. In this way, people can observe the spatial distribution of the magnetic field around the permeable body. The display results are shown in Fig.3、Fig.4. These results can be likened to animals, such as sea urchin and hedgehog, giving people unlimited imagination.

The teaching tool is well designed, people can easily handle it and has a good display result. Not only can we use it to show the spatial distribution of the magnetic field of spherical permeable body, but also can use it to teach some relevant knowledge about electromagnetism, such as the magnetic field line, permeable

materials, and non-permeable materials. Besides, a novel material—ferrofluid—can be known by three-dimensional dynamic ball, such as its special field-induced interfacial phenomenon.



Fig. 3. The magnetic field of permanent magnet showed by ferrofluid.



Fig. 4. The magnetic field of electromagnet showed by ferrofluid.

### 2.3 Principle Analysis

As is shown in Fig.5, the spherical permeable body is magnetized and yield magnetic field  $H$  under the condition of an external magnetic field, resulting in ferrofluid's three-dimensional spikes. These spatial distributions of the three-dimensional peaks reflect the spatial distribution of the magnetic field around the spherical permeable body. So people can get the spatial distribution of the magnetic field around the spherical permeable body according to the experimental phenomena.

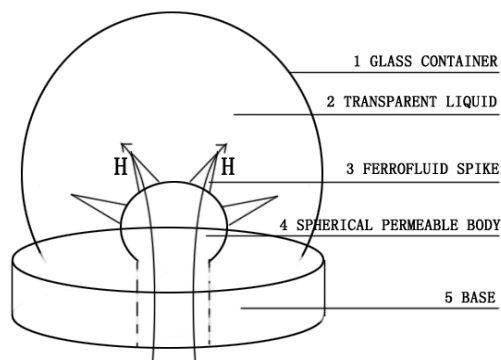


Fig. 5. Schematic diagram of the principle.

### 3 Conclusions and Outlook

Three-dimensional dynamic ball for revealing magnetic field breaks through the traditional two-dimensional planar magnetic field distribution mode and shows the invisible magnetic field distribution, magnetic field lines and other physical phenomena vividly and dynamically. It is easy for students to understand abstract concepts owing to the magnetic field lines shown by the ball visible in mind.

Until now, people took it for granted that strong magnetic property occurred in solid rather than liquid. The teaching tool enable students to observe the ferrofluid in a magnetic field not only magnetically, but also can control with an extra applied magnetic field, which impress student by exquisite 、magic and dynamic pictures. It plays an indispensable role in stimulating students to study nano-liquid functional materials deeply, fostering students' awareness of innovative, improving the practical ability of students.

To sum up, the three-dimensional dynamic ball for revealing magnetic field breaks through the traditional magnetic field distribution mode, applying two-phase solid-liquid colloidal solution “ferrofluid” into showing the spatial distribution of magnetic field creatively, carrying profound scientific and cultural knowledge and providing better service for education. So, the research of teaching tool based on ferrofluid will be one of the hot R & D of ferrofluid's application, which has promising and far-reaching economic and social benefits.

## References

- [1] Li Xuehui, Sun Qiao, Fu Yanqing, et al. The Development of Ferrofluid Apparatuses for Presenting Magnetic Field [P]. China : 200910012867.8 , 2009-07-31. (in Chinese)
- [2] Li Xuhui. Nano-ferrofluid—Preparation, Performance and Application [M]. Beijing : Science press , 2009 : 69-70. (in Chinese)

---

---

## Scientific Popularization through Scientific Explanation of Magic and Wonders

I. Human and R. Khan  
Receptice Essential Scientific Education  
Advancement Research  
Committee for Humanity (RESEARCH)  
67 Anta, Near Mohni School, Shahjahanpur-  
242 001, Uttar Pradesh, INDIA  
research.org@rediffmail.com

**Keywords:** science behind magic and wonders, science experiments, scientific temper.

**Abstract.** The development of a country rests on the scientific and technological all round development of that country. Scientific literacy is also very important phenomenon for the development of any country. Dr. A.P.J. Abdul Kalam's vision 2020 can not be materialized without inculcating scientific temper in young and amateur scientists. India can be stronger and independent by adopting the scientific temper by popularizing science and technology through educational institution at gross root level. Progress of science and technology is essential for the self reliance and overall development of the country. The explanation of scientific reasons behind magic and wonders may be one of the stronger ways of scientific popularization. In this way, scientific temper can be developed not only in school going children but the common man may also be made aware of it which will help in removing the dogma and superstitions.

## How Much One Can Learn by Doing Self: A Study

R. Khan and I. Human  
Receptice Essential Scientific Education  
Advancement Research  
Committee for Humanity (RESEARCH)  
67 Anta, Near Mohni School, Shahjahanpur-  
242 00, Uttar Pradesh, INDIA  
research.org@rediffmail.com

**Keywords:** astronomy, scientific temper, students, survey.

**Abstract.** The vast sky with innumerable twinkling stars has always been the source of attraction and interest for mankind. On one hand twinkling stars, rising and setting of the Sun and Moon have remained the source of attraction and enjoyment, on the other hand solar eclipse, meteoroid shower and comets have been the source of fear. For centuries human being has always been curious to know the phenomenon behind them about which they have been reading and listening in the form of tales and stories. For time to time latest scientific and technological subjects have been included in the syllabus of schools as well as the print and electronic media have rendered the information to masses. A survey was held in Junior High Schools students to know the standard of the knowledge of the students regarding astronomy in connection with the **International Year of Astronomy-2009** and a questionnaire was supplied to test their status of awareness.

---

---



## Understanding Weather and Climate through PROBE-Orissa Programme

B. Mohapatra  
S U P R A T I V A (TRC)  
Fakirpada, Cuttack-754100, Orissa, INDIA  
suprativa@sify.com, www.suprativa.org

**Abstract.** Orissa, a province of India is placed at the head of the Bay of Bengal where weather is formed. A slight change in the sea's behaviour can cause an immediate impact on the coast. Low pressures in the Bay cause heavy rains and cyclones in the sub-continent, especially in Orissa. These cyclones and depressions involve circulation over thousands of kilometres and form links Orissa's atmosphere with the entire planetary circulation system. Going by the key parameters of climate like temperature and rainfall, the climate may worsen in Orissa. However, the full impact of climate change does not show up immediately. It triggers changes slowly but certainly.



Besides, it is well known that the global warming and environmental degradation may have very serious consequences for the present and future generations. Every segment of the society including government, scientists, non-governmental organizations, industries, academicians and general public are concerned about the climate change and the current environmental issues. So, the meteorology as a subject can be made instrumental in converting a student at school level from a passive recipient of information to active provider of information. There is a scope of increasing the opportunity for participatory and interactive learning for school children, help students reach higher level of achievements in science education.



Considering the needs, PROBE-Orissa (Participation of Youth in Rea-time/field Observation for the Benefit to Education) is conceived for school children to lay hands on scientific experiments, observe and comprehend metrological changes and consequential happenings at local level. It aims at understanding weather and climate in Orissa costal belt and to encourage participation of young school children in data acquisition, generation, use and dissemination of field data. SUPRATIVA, a leading NGO of the state has been appointed as a Technical Resource Centre by the Department of Science & Technology, Government of India to implement the programme in Cuttack and Jagatsinghpur districts of Orissa. It involves opening a PROBE Weather Laboratory within the school premises in which the students are encouraged to take and record daily weather observations. In this multi-

institutional project, a two-way relationship is envisaged between school Students/Teacher and Technical Resource Centre.

The specific objectives of the PROBE-Orissa programme are as follow:

- To provide an opportunity for participatory and interactive learning for schools children.
- To shift the emphasis from a student being a passive recipient of information and knowledge to become an active collector and author of relevant and useful information.
- To do meteorology data acquisition and its transformation into useful knowledge and information.
- To contribute to scientific understanding of weather and its impacts in various fields, especially agriculture, soil and water conservation and hydrology.
- To establish a closer interaction among students from different schools and reach higher level of achievements in science education.
- To bring schools, institutions of higher learning and grassroots community organizations into networking relationship.
- To monitor environmental trends, climate change and meteorology in the region.
- To create a micro-level database on meteorology, climate and natural resources and related fields.

Both observing and learning about weather and climate is emphasized in this project. Observation protocols are devised and the data collected is sent to Technical Resource Center (SUPRATIVA) and DST and also to India Meteorological Department for quality check and consistency. SUPRATIVA has extended this programme to 20 selected schools Cuttack and Jagatsinghpur districts. From weather data base created by school children, the DST is utilizing the PROBE data for research in universities on the topics aiming at water management, climate change, disaster mitigation, bio-diversity as well as meso-scale modeling studies to supplement our efforts in achieving better local forecasts. Through participation in PROBE in different schools, young minds are be exposed to scientific

intricacies of weather, which will be moved to pursue science as a career and develop better understanding to take safety measures from weather related hazards.

The nature of scientific problems are being studied under this project are related to extreme weather conditions like cyclone, flood, drought, heat wave, change in monsoon pattern etc. The suggested protocols are:

- Temperature: Minimum, Maximum, Dry Bulb, Wet Bulb
- Wind: Direction, Speed
- Clouds: Types, Amount
- Sunshine: Insolation, Radiation
- Evaporation: Relative Humidity

The specified meteorological instruments have already been installed in all schools and all are now in operation. The temperature in the air is measured by thermometer to know about the weather conditions. The maximum thermometer is a mercury thermometer which is installed horizontally. It is giving the reading of highest temperature reached in a day. Similarly, the minimum thermometer is an alcohol thermometer that is used to measure the lowest temperature attained in a day. The dry bulb thermometer is a mercury thermometer which is recording the maximum ambient air temperature. The wet bulb thermometer is wrapped with a small piece of muslin cloth around the bulb to keep it moist and record relative humidity of the atmosphere.

The students are using rain gauge for measurement of rainfall. It has a rain collector funnel and a measuring glass. The water collected in the funnel is giving the total rainfall of every day. The measurement of wind velocity and wind direction is important for knowing the weather. The instrument consists of a flat fin at one end and a cylindrical mild steel counter weight as pointer at the other end. The wind vane is installed at a height of 10 meters from ground level. For measuring the wind velocity, students are using cup anemometers. A specific format has been developed by SUPRATIVA (TRC) in consultation with experts for the students to collect and record weather data from their meteorological instruments everyday. The format contains information on daily weather condition like minimum and maximum temperature,

humidity, moisture, rainfall, wind velocity and its direction.

---

---

### Hands on Science in Makkal TV

A. S. Pandi  
Presidency College, Chennai – 600 005,  
INDIA

**Abstract.** Science is a method of thinking process. Children learn science best and understand scientific concepts better if they are able to have hands on experience. Hands on science can help children think critically and gain confidence in their own ability to solve problems. Simple and cost effective experiments with materials used in daily life have been conducted. These experiments were recorded and telecast by Makkal TV, a Tamil channel as a series of 30 episodes (Kandupidi. Kandupidi) , each of 30 minutes duration. These programmes involve school children in the hands on science presentation. These programmes were well received by the general public and quite popular among school children as they kindle their interest in the understanding of difficult concepts in science through the learning by doing. This paper presents the views and feedback of the programmes.

---

---

### Promoting the Concept of Ecoschool for Sustainable Environment in Cuddalore District of Tamil Nadu, India

K. Sampath  
District Institute of Education and Training  
Vadalur – 607 303, Cuddalore – District,  
Tamil Nadu, INDIA  
samppul@yahoo.co.in

**Abstract** Sensing that in these days of fast deteriorating environment mere environmental education will not make a desirable impact, the concept of ecoschool is being promoted in Cuddalore district of Tamil Nadu State. The present study was carried out involving 170 teachers with 75 male and 95 female teachers from all the 50 ecoschools during July 2008 to March 2009 to evaluate and improve further the knowledge, attitudes, skills (practices) and performance of teachers. To study these components tools namely “test” “attitude scale”, “application inventory” and “rating scale”, respectively are developed. The grand mean knowledge score in the pre-test is 60.99% and that of post-test is 91.91%. Similarly, the grand mean attitude score of the teachers in the pre-test and post-test is 83.39% and 90.0%, respectively. All the teachers responded that they practised all the given activities. While the grand mean rating score recorded was 58.52%, the overall mean rating score for the two dimensions “Ecology” and “Hygiene and Sanitation” was 61.78% and 55.25%, respectively. Even though the teachers are known to have possessed more knowledge about and attitude towards the environment they did reflect it in their performances in taking up environmental conservation activities in the ecoschools. Further, though the teachers have responded to have carried out environmental conservation practices, in real term they did not perform all such practices they said to have practised. In these days of environmental degradation it becomes essential to make the teachers to realize the need for performing with more commitment with the ultimate intention of sensitizing students so as possess environmental ethics and mould them for the cause of environmental conservation.

**Keywords:** ecoschool, environment, teachers, knowledge, attitudes, values, performances, pre-test, post-test.

## Introduction

While the education system has undoubtedly undergone significant progress, a lot still needs to be done to enhance further the quality of education. The efforts to institutionalise Environmental Education (EE) at all stages of education have been accentuated with the directive of the Supreme Court of India that the EE should be taught as a compulsory subject at all levels of education. The Government of India has taken various efforts such as incorporation of EE at all levels of education, preparation of model syllabus of EE through the NCERT, implementation of National Curriculum Framework 2005 in the development of new textbooks, teacher training programmes and materials. All these initiatives are significant attempts in the context of the United Nations declaration for the period from 2005 to 2014 as the Decade of Education for Sustainable Development (DESD). The DESD visualizes a world where every one has the opportunity to benefit from education and learn the values, behaviour and lifestyles required for a sustainable future and for positive social transformation (CEE, 2007). Nevertheless, several efforts made by the government and various agencies for the transaction of EE at the elementary level are not found to be in consonance with the initiatives being enforced. Such an undesirable situation could be due to lack of adequate competency among teachers in the area of science in general (Jain, 2004) and environmental science in particular (NCERT, 2001 and Sampath *et al.* 2005). Further, as the teachers themselves do not have environmental attitudes and values they are unable to realize the importance of practising students on environmental conservation related activities and hence the children are lacking of environmental values. In this context it becomes very essential to nurture environmental attitudes and values among elementary teachers. To accomplish this task an effort has been made in promoting the concept of eco-school by carrying out a few environment related activities with a view to practising the teachers and students so as to nurture desirable environmental attitudes and values amongst them. The aim of the present

study was to evaluate and improve further the knowledge, attitudes, skills and performances of the teachers on the environmental conservation activities being taken up in the eco-schools.

## Ecoschools

With the aim of promoting knowledge about and developing positive attitude and values among teachers and students towards the environment, an initiative has been made since 2004 in the elementary schools of Cuddalore district by involving them in the Environmental Education (EE) and conservation activities (Sampath, 2007). The activities under EE include organising training programmes on EE for teachers, students and Village Education Committee (VEC) members and involving teachers and students in the observation of important environment related events. The activities under environmental conservation include planting of 5 to 20 saplings in the school campuses, provision of adequate number of green and red coloured dustbins for source segregation of wastes into degradable and non-degradable ones and construction of two garbage pits in each of the ecoschools for disposal of garbage accordingly and practising of students on these activities. Hitherto, in a phased manner in two blocks of Cuddalore district viz., Kurinjipadi and Kammapuram 50 schools have been promoted as ecoschools. The saplings are planted more scientifically by providing with sapling-guard made of bamboo spikes. In all the 50 eco-schools so far nearly 600 saplings have been planted and taken care of by forming "Tree-mate" groups by involving students and with the active participation of school administration and by regular monitoring.

## Methodology

In the execution of the present study experimental method was employed.

## Study Area

In Kurinjipadi and Kammapuram blocks of Cuddalore district primary and upper primary schools numbering 50 have been promoted as ecoschools. The present study was carried out in all the ecoschools.

## Sampling

Among the 210 teachers working in all the 50 ecoschools altogether 170 teachers with 75 male and 95 female teachers were involved in the conduct of the training programme on environmental education during the study period. However, all the teachers were taken into account in assessing the performance of the ecoschools.

## Tools

Since, the knowledge, attitudes, practices and performance of teachers play a pivotal role in moulding the character of students, these aspects are considered essential to evaluate them. Thus, to study these four aspects (knowledge, attitudes, practices and performance) of teachers, tools namely, test, attitude scale, application inventory and rating scale, respectively were developed.

## Test

The test consists of questions under three types namely, “yes / no”, “multiple choice” and “fill-in the blank”. The “yes / no” type comprises of 25 questions under five dimensions namely Biology, Ecology, Pollution, Water Resources and Hygiene and Sanitation. The number of questions under each dimension is 5, 6, 4, 5 and 5, respectively. The other types namely “multiple choice” and “fill-in the blank” included 20 questions each under the said same five dimensions with 4 questions each. All the questions are developed based on the concepts related to environmental concerns given in science and social science textbook of standard I to VIII of Tamil Nadu State Board. All the questions carry one mark each. Thus the total score for the test is 65.

## Attitude Scale

The attitude scale consists of 25 statements under the same five dimensions as given for the “test”. The number of statements under each of the dimensions is 4, 6, 5, 5 and 5, respectively. The statements were given under 4 point Likert scale with options such as “Fully Agree”, “Agree”, “Disagree” and “Fully Disagree” and scores being 4, 3, 2 and 1, respectively. The scores for negative statements are given vice

versa. The statements are, similar to that of questions given under ‘test’, developed based on the concepts on environmental concerns given in the science and social science text book of class I to VIII of Tamil Nadu State Board. The total score for the attitude scale was 100.

## Application Inventory

The application inventory includes of 5 statements with three activities each. Among which one would be chosen by the teacher. The statements are given under four dimensions with one statement each under the dimensions “Botany”, “Zoology” and “Water Resources” and two statements under the dimension “Hygiene and Sanitation”. The responses of the teachers are classified and scored.

## Rating Scale

The rating scale was constructed by making 24 statements under two dimensions viz., “Ecology” and “Hygiene and Sanitation” with 14 and 10 statements, respectively. The statements were given under 4 point scale such as “Very Good”, “Good”, “Bad” and “Very Bad” and the score being 4, 3, 2 and 1, respectively. The statements were developed based on the concepts related to environmental conservation activities taken up in the ecoschools and also environmental concerns given in the environmental science / science and social science textbook of class I to VIII of Tamil Nadu State Board.

## Administration of Tools and Data Processing

The tools such as “test” and “attitude scale” are administered both before and after the conduct of the training programme. The “application inventory” is administered to the teachers only before the conduct of the training programme. Before administering the tools, the teachers are instructed to read the statements thoroughly and respond carefully. The teachers are asked not to write their names on the tool. The performance of teachers in taking up environmental conservation activities is observed and evaluated by the investigators by making frequent visits to the ecoschools and marked on the “rating scale” without revealing to the headmasters (HMs) and teachers. The collected

data are processed and percentage scores calculated.

Thus, with the view to sensitizing teachers on various aspects of environmental education and conservation aspects this study is carried out with the following objectives.

- 1) To evaluate and promote further the knowledge, attitudes, skills and performance of teachers on environmental concerns.
- 2) To nurture right attitudes and values among teachers towards the environment by contextualizing environmental conservation activities.
- 3) To make desirable changes in the physical environment of the schools by involving teachers and students.
- 4) To narrow down the gap exists between the practices and performances.

### Knowledge of Teachers

The score presented here for the component knowledge, comprises the mean scores of three types of questions viz., “yes / no”, “fill-in the blank” and “multiple choice”.

The grand mean knowledge score recorded in the pre-test was 60.99%. The overall mean score registered for the male teachers was 57.93% and that of female teachers it was 64.06%. The record of grand as well as overall mean score of above 50% mark in the present study showed that the teachers from the ecoschools have considerable knowledge on environmental concerns. After interventions a remarkable increase in the knowledge of the teachers was recorded in the post-test. The grand mean post-test score recorded was 91.91%, an increase of 30.02 percentage points over the pre-test score. Between male and female teachers a marked difference in the overall mean score was recorded. The overall mean post-test score of the female teachers was 7 percentage points higher than the overall mean score of 88.02% recorded for the male teachers. In the study conducted earlier by Sampath *et al.*, (2005) the mean knowledge score of the teachers from non-ecoschools from Pondicherry region on

environmental concerns is only 47.22%. It is assumed that the knowledge of teachers from the same ecoschools before promoting the concept of ecoschool would have been at the same level or even still worse. It is also surmised that this could be the situation all over the state of Tamil Nadu. The record of the mean knowledge score of teachers from the ecoschools even in the pre-test is relatively higher than 50% mark, could be attributed to the interventions made in the ecoschools since its inceptions. Thus, promoting the concept of ecoschools will help improve further the knowledge of teachers on environmental conservation. Albeit, the increased knowledge is not seemed to have changed the attitudes and performance of the teachers it is, however, expected that in the course of time with the continued efforts, a desired impact on the performance of the teachers could be noticed.

### Attitude of Teachers

The grand mean attitude score of the teachers in the pre-test was 83.39%. No marked variation in the score gender wise was recorded. After intervention only a marginal increase in the attitude score was recorded. The grand mean post-test score recorded was 90.9%. In the post-test also the difference in scores gender wise was only marginal. No drastic variation in the overall mean attitude score among the dimensions was recorded both before and after interventions. Among the dimensions studied highest overall mean pre-test score of 88.72% was recorded in the dimensions “Hygiene and Sanitation” and the lowest mean pre-test score of 76.6% was registered for the dimensions “Ecology”. In the post-test the highest overall mean attitude score of 95.25% was recorded for the dimension “Biology” and the lower overall mean attitude score of 83.64% was registered in the dimension “Water Resources”. Possession of largely desirable attitude towards the environment by the teachers was evident from the record of greater attitude score both before and after interventions. The intervention did not make any considerable impact in improving further the attitude of teachers was known from the record of only slight increase in the attitude score of the post-test. Even though the teachers exhibited their desirable environmental attitude to a large extent, conversely such attitudes are not found to have

been reflected in their performances. It is evident from the poor maintenance of the physical environment of the school and the unconcerned nature of the teachers about the environment in general. Hence, it is very essential to make the teachers to perform in conformity with the attitude exhibited on the paper or to transform the pseudo-attitude into real attitude.

### Practices of Teachers

In the present study the responses of the teachers for 5 statements given under practices have been elucidated. Under the dimension “botany” the statement “The way by which you involved “tree-mate” groups in the maintenance of saplings” 73.33% of the teachers with 36.36% of male and 63.64% of female teachers responded to the activity “I myself involved “tree-mate” groups in the maintenance of the planted saplings. Of the remaining 26.67% of teachers with 43.75% of male teachers and 56.25% of female teachers revealed that “I involved “tree-mate” groups under the supervision of class leader. However, interestingly no teacher responded to the activity “no effort was made in maintaining the saplings”. From the responses to the statement, it is evident that all the teachers are seemed to have practised students in nurturing saplings so as to develop right attitudes and values.

For the statement under the dimension “zoology” “What was your reaction when the students committed cruelty to living beings” a large number of 96.66% of teachers with 37.93% of male and 62.07% of female teachers responded to the activity “I advised students not to indulge in such acts”. The remaining small number of 3.34% of teachers with 50.0% of male and 50.0% of female teachers responded to the activity “I did not reprimand students as it was an inherent act of childhood”. Eventually no teacher preferred to answer for the activity “I ignored the act of such indulgence by the students”. It is from the responses of a large number of teachers for the first and last activities, it could be inferred that teachers are concerned with biodiversity conservation by inculcating a sense of awareness among the students.

The preparedness of the teachers on the crucial issue of water conservation also was studied. The statement “The way you reacted

when water leaked from water pipes in your school” under the dimension “water resources” a large number of 65.0% of teachers with great number of 43.58% of male teachers and relatively a little higher number of 56.42% of female teachers responded to the activity “I myself took efforts to mend it”. It was really appreciable that a large number of teachers are seemed to have prepared themselves to take up the cause of water conservation. Further, a considerable proportion of 21.60% of teachers with 46.15% of male teachers and 53.85% of female teachers responded to the activity “I sought the help of other teachers in attending to the work”. The remaining 13.40% of female teachers alone preferred to answer to the activity “I sought the help of members of village education committee to get done the work. The responses of the teachers to all the three types of activities indicated that teachers showed interest in taking up measures to conserve water in their work place.

The responses of teachers for the statement under the dimension “hygiene and sanitation” “The way you practised students in the handling of garbage by the students” a large chunk of 88.33% of teachers with 37.73% of male teachers a little over 62.27% of female teachers responded to the activity “I practised students to segregate garbage into degradable and non-degradable ones and put them into two different dustbins”. The remaining small number of 11.67% of teachers with 42.85% of male teachers and 57.15% of female teachers responded to the activity “I practised students to use dustbins without any further instructions on segregation”. Incidentally, no teacher was found to have preferred the activity “I never practised students in the handling of garbage”. Since all the teachers invariably responded that they practiced students in the proper handling of garbage, it could be inferred that teachers have understood the need for using dustbins and segregating the wastes.

Under the same dimension “Hygiene and Sanitation” for the statement “The ways you adopted in making the students follow personal hygiene” 41.66% of teachers with 28.0% of male and 72.0% female teachers responded to the activity “I observed by myself the personal hygiene of students individually”. Further, a considerable chunk of 58.34% of teachers with 45.71% of male and 54.29% of female teachers

responded to the activity “I involved students with the highest order of personal hygiene to observe other students”. For the activity “I never showed any interest in the personal hygiene of students considering that it was the responsibility of their parents” no teachers preferred to answer. Since no teacher preferred to this activity it could be ascertained that all the teachers are highly concerned with the personal hygiene of the students.

### **Rating Score**

The performance of the teachers in the taking up of environmental conservation activities at the ecoschools was evaluated, as said elsewhere, by administering the “Rating Scale”. The grand mean rating score was 58.52%. The overall mean rating score for one of the dimensions “Ecology” was 61.78% and that of the other dimension “Hygiene and Sanitation” it was 55.25%. As the grand mean score and the overall mean scores of the two dimensions are marginally above 50% mark, it could be ascertained that the performance of the teachers in the said two dimensions was only mere satisfactory.

### **Ecology**

This dimension included 14 statements covering various activities like maintenance of saplings by the headmasters and teachers, involving of “tree-mate” groups, conduct of field-trip for students, concern on biodiversity conservation, mobilizing community for the welfare schools, improvement of physical environment of the schools and efforts of the teachers on water conservation. The overall mean rating score of this dimension is 61.78%. As this score is considerably (12 percentage points) higher than 50% mark it can be construed that the performance of the teachers on the said areas is satisfactory. Among the schools studied the highest mean rating scores of 87.5% was recorded at the P.U. Middle school at Ranganathapuram and the lowest mean rating score of 32.14% registered at three schools viz., P.U. Primary school at Santhavelipettai and Kurijipadi (west) and P.U. Middle school at Kundiyamallur. The increase in the performance to almost 12 percentage point is a result of the interventions made during the last five years after promoting the traditional schools as

ecoschools. In the event of not promoting the concept of ecoschool the rating score would have been less than 50% mark. However, as the mean rating score registered in the present study is only 61.78% there is a much gap to reach the 100% level. It is, thus, expected that through sustained efforts, planned to put in, it could be possible to improve further the performance of the teachers. Of the 50 schools studied the mean rating score of 10 schools was below 50% mark. The reason for the record of relatively low performance in these schools may be largely due to non-committed nature of the teachers. The lack of infrastructures like compound wall and water are the causes for the poor performance of the ecoschools as claimed by the teachers do not hold good. This could be justified from the well performance of the other ecoschools despite all such problems.

### **Hygiene and Sanitation**

This dimension consisted of 10 statements related to activities such as binning of litter, personal hygiene of students, usage of dustbins and maintenance of garbage pits, maintenance of classrooms and campuses, activities of noon meal workers. The overall mean rating score of the dimension was 55.25%. Among the schools studied the highest mean rating score of 77.5% each was recorded in the P.U. Middle schools at Ranganathapuram, S. Pudhur and Ellappanpettai. Unlike that of the other dimension here the increase of only 5 percentage point over the 50% mark is achieved. Even, the increase of 5 percentage points itself should be considered as a remarkable achievement as the hygiene and sanitation aspects of the non-ecoschools in general is so worst. When looking at the wide gap between the registered overall mean score (55.25%) and the achievable goal of 100% level, a lot more needs to be done. It could be, however, possible to achieve greater level of performance in this aspect too as it has been decided to continue the work with renewed vigour. Among the schools studied the overall mean rating score of 19 schools was below 50% mark. The lowest mean rating score of 25% was recorded in P.U. Primary school at Santhavelipettai and A.D. W. middle school at Arangamangalam. Even though basic amenities related to this dimension like provision of two dustbins to all the classrooms, construction of



two garbage pits to each ecoschool, cleaning of garbage pits and campuses, monitoring every month and conduct of training programmes the HMs and teachers do not show any interest and concern in the aspects related to this dimension to a great extent. The reasons put forth by the teachers for not being able to perform well on this front are teacher related factors such as heavy workload, non-cooperation among teachers, ill-health and teachers' home at far off places; school related factors like absence of compound wall, non-availability of water, lower enrolment of students and nature of location of school and community related factors like non-cooperation among people, PTA members, unconcerned nature of noon meal personnel. However, these reasons do not hold good because in the case of best performing schools such as the one at Ranganathapuram too despite all such problems the teachers perform well in both the dimensions as a result of their committed nature. Further, the author of this work himself takes up all the activities in his work place as done by the teachers in the schools and performs to a great extent so as to be a role model for the teachers from the ecoschools to follow the example. The work place of the author is often visited by the teachers from the ecoschools for inservice training programme. It is firmly believed that with the efforts put in, there will be gradual change in the performance of the teachers.

Even though the teachers from the ecoschools were known to have possessed considerable knowledge on environmental concerns as reported from this study and also from the previous study (Sampath, 2008) from the poor performance of the ecoschools it could be ascertained that the possession of knowledge alone among the teachers will not help them in taking up environmental conservation activities. In addition to equip teachers with necessary knowledge, as it is essential to make sustained efforts so as to involve them in environmental conservation activities they are involved in such activities in the ecoschools to promote environmental attitude, values and skills as suggested by Govinda (1994), Rajput (2003), Sharma (2004), Dhawan *et al.*, (2005) Venkateshwarlu (2006) and Blum (2008).

### **Mismatch between Practices and Performances**

As already discussed there is a wide gap between attitudes of the teachers and their performance. Similarly, there exists a hiatus between the "practices" which are said to have been carried out by the teachers and their real performance. For the statement under practices "The way by which you involved "tree-mate" groups in the tending of saplings" all the teachers including the HMs responded that they involved "tree-mate" groups either directly under their supervision or indirectly under the supervision of the students class-leader in the maintenance of the saplings. But, in reality when studied their performance on this aspect through rating scale, the mean rating score recorded is 71%. The wide difference of 29.0 percentage points between the said to be "practices" and the performance (rating score) indicates that teachers failed miserably in involving "tree-mate" groups in the tending of saplings. Relatively low performance of the teachers on environment related activities was an indication that teachers did not have high moral judgment. In general, teachers having low moral judgment can not help students in the development of desired attitudes and values (Das, 2003). Since the teachers in general at the elementary schools do not have much accountability with regard to the academic activities, they find ample time each day. But as a result of lack of commitment in improving the school environment vis-à-vis promoting environmental ethics among the students they waste lot of time. If the teachers are inclined to perform on this aspect by involving students it will beside help nurturing attitudes and values among the students, will facilitate in improving the physical environment of the school. Since knowledge is considered to be the basis for the formation of attitudes and values as reported by Dhawan *et al.*, (2005) and Sampath (2008) all the teachers including teachers from all the non-ecoschools should be involved in in-service training programme on environmental education in realistic term.

In the area of biodiversity conservation under "practices" for the statement "What was your reaction when the students committed cruelty to living beings" a large number of 96.66% of teachers indicated that they would not allow any

student in harming the living beings. However, the mean rating score for the statement “Preventing students from committing cruelty to the living beings” was 70%. As the difference in the mean scores between “practices” and the performance (rating score) is 30.0 percentage points it could be adduced that the activities which are purported to have been practised by the teachers was not largely true.

In the evaluation of “practices” with the statement “When water was going waste in your school the efforts you undertook” all the teachers (100%) responded that they took measure to address the problem of wastage of water either by taking efforts in their own or by seeking the help of their colleagues and others. However, the real performance of the teachers was studied through the statement “Attending to work by the HMs and teachers when water going waste in the schools” recorded mean rating score was 57.5%. Thus the wide difference of 42.5 percentage points between “practices” and performance, which was alarmingly high, indicates that the performance of the teachers do not comply with the “practices” as claimed to have been done by the teachers. Even though many concepts on the importance of water conservation were incorporated in the text books right from Ist standard and also interventions made through the present study, still the situation in many of the schools was in such a way that water was found leaking from the drinking water structures, water tanks and toilets. Though the teachers were found to possess with considerable knowledge on this dimension (over all mean post-test score was 92.45%) which is known from the present study and also the study done already (Sampah and Sundaramoorthy, 2007 and 2008) from their tendency of not showing any concern in preventing or minimizing wastage of water, it becomes obvious that they did not have right attitudes and values in this regard. Hence, it become very essential that like other dimensions teachers should be put into rigorous practices so as to develop right environmental attitudes and values.

Still for the other activity under the dimension “Hygiene and Sanitation” for the statement “The way you practised students in the handling of garbage” under “practices” all the teachers (100%) including HMs indicated that they practised students in the proper segregation of garbage into degradable and non-degradable one.

However, in reality when assessed the performance of the HMs and teachers in practising students in the use of dustbins the mean rating score for the two statements related to this aspect is only 66.5%. The wider variation of 35.0 percentage points between “practices” and performance (rating score) indicated that the HMs and teachers did not commit fully to their profession, particularly environmental education. It is quite evident from the litter strewn in the classrooms, entire campus more specifically the backyard. The reason for the failure of the HMs and teachers in practising students was that they themselves did not carry out such practices either at home or elsewhere. Such being the situation when they were compelled to practice themselves and in turn practice students, they find it difficult to accustom to the habit. As the habit formation takes quite a long time it is expected that in the course of time they will habituate to this exercise and then practice students properly. The other reason for the relatively poor performance of the schools in this aspect is the frequent transfer of HMs and teachers from the ecoschools. As a result teachers from non-ecoschools who were bereft of such practices took some time to get acquainted with the activities taken up in the ecoschools.

### Conclusions

In the present study it has been realized that the promotion of traditional schools into ecoschools offers many advantages both for the performance of the teachers and the schools as a whole. For instance the knowledge of the teachers increased from 60.99% to 91.91%. Similarly, the concept of ecoschool facilitated in promoting the attitude of the teachers, which is evident from the record of mean attitude score of 90.0%. Besides, the increased knowledge and attitudes achieved through the interventions made, helped improve the performance of the teachers. In the dimension “Ecology” a 12 percentage point increase in the performance is recorded. Similarly, in the dimension “Hygiene and Sanitation” the performance has increased to 5 percentage point level.

## References

- [1] Blum, N. 2008. Environmental education in Costa Rica: Building a framework for sustainable development. *Int. J. Environmental Development* 28:348-358.
- [2] CEE 2007. Environmental Education in the Indian School System: Status Report 2007. Centre for Environment Education, Ahmedabad. pp.159.
- [3] Das, R. C. 2003. Role of Teacher in Commitment to Values. In: *Teacher Commitment* (Ed. K. Walia), National Council of Educational Research and Training, New Delhi. Pp.114.
- [4] Dhawan S., L. Rawat and V. Sharma, 2005. Environmental education in pre-service teacher education, *J. Indian Education*, XXXI (2):29-44.
- [5] Govinda, R. 1994. Integration of environmental education into elementary teacher training programmes. In: *Source book on environmental education for elementary teachers*. Published by National Institute of Education Planning and Administration and UNESCO-UNEP – International Environmental Education Programme.
- [6] Jain, M. 2004. Teaching of science at the elementary stage: Observation from a qualitative study *J. Indian Education* XXIX (2):7 – 22.
- [7] NCERT 2001. Environmental orientation to school education – A training module for southern region, Publication Department of National Council of Educational Research and Training, New Delhi. pp.199.
- [8] Rajput, J.S. 2003. The values context in environmental education. *J. Value Education* 3 (2); 5-13.
- [9] Ramakrishna, A. 2003. A study of environmental awareness among high school students. *J. School Science*, XLI (2): 78 – 90.
- [10] Sampath, K. 2007. Eco-school – A viable strategy for sustainable environment. Newsletter, District Institute of Education and Training, Vadalur 7 (1): 2-13.
- [11] Sampath, K. 2008. Promotion of knowledge about and attitude towards environmental concerns of elementary teachers from ecoschools of Cuddalore district. Research project report. Directorate of Teacher Education Research and Training, Chennai. pp. 109.
- [12] Sampath, K. and T. Sundaramoorthy, 2008. Knowledge of teachers and students on environmental concerns from elementary ecoschools of Cuddalore district of Tamil Nadu State. In: *Proceedings (abstract) 95<sup>th</sup> Indian Science Congress* Section: Anthropological and Behavioural Sciences; p.13.
- [13] Sampath, K., T. Sundaramoorthy and V. Ramalingam 2005. Educational efficiency of elementary teachers on environmental concepts – A study from Pondicherry region. In: *Proceedings of quality dimensions initiatives: Action research and innovative practices*, 140 – 151. DEP – SSA, New Delhi.
- [14] Sharma, R.C. 2004. Implications of environmental education in teacher education. *J. Indian Education*, XXX (1):5-13.
- [15] Venkateshwarlu, D. 2006. Changing role of the teachers. *J. Indian Education*, XXXI (4):35-39.
- [16] Yadav, S. K. 2003. Quality of pre-service and in-service teacher training. *J. Indian Education* 20 (1): 5-13.
- 
-

## Hands on Science: Towards Total Knowledge Transfer for S&T Communication

L. Kala  
Centre for Energy Studies,  
Indian Institute of Technology  
Hauz Khas, New Delhi – 110016, INDIA  
ldkala@yahoo.com

**Abstract.** ‘Hands on science’ has been the budge word since the science and technology took the front seat in the affairs of development of knowledge from more modern perspective. This perspective was totally driven by understanding of nature and use of knowledge and skills thus gained for the welfare of human race.

This paper analyses the development in science and technology with reference to a new concept named here as ‘Total Communication’. It has made possible where the human race stand today. At the very basis of this hypothesis, lies the need for the communication. But then, the question arises, what level and form of communication. This paper recognises the very fact that different levels of communication produces distinctly different results.

Emergence of science required higher level of communication skills and all higher or derived forms of knowledge emerging out of scientific advancements necessitated more effective forms of science communication. The concept of Total Communication is ever developing as itself the very tenets of science and technology.

### 1. Introduction

Communication would mean ‘simplification’ in layman terminology. But this term ‘communication’ has a lot of restrictions and limitations intrinsically associated with it.

Mere communication was not enough since the day scientific understanding began taking shape. If it was enough for the development of human civilization, then we would not have been where we stand today. This means that the spectacular progress human beings have made in understanding nature would not have been possible if we would have relied merely on basic forms of communication. Especially when it

comes to communicating to such an extent that the idea or concept is fully communicated (transferred). The extent of communication required now was such that the source of that communication on knowledge front is matched by the receiver or the target to a great extent after the communication process is over. This awareness of the new realities has made all the difference through all these years.

Hands on science is very appropriate word to this new essentiality. It was born as a concept on the scene the day technology arrived in the hands of mankind. Technology is predecessor to the concept for the technology, namely science, Hands on science, is capable of transferring the knowledge of both, the science and the technology to the target or receiver. Hands on science certainly belong to the activity pertaining to ‘communication’ – more pertinently – science and technology communication and has been best used by teaching and training forms of knowledge transfer tools.

Hands on science has a prerequisite, of the activity being actually being performed by hands, by the receiver of that knowledge. Teaching is communication with the different goal. Communication is generally believed to be voluntary, which is not true with teaching. The recipients at least, are not voluntary entirely. They are undertaking it as a source of acquisition of life skills, necessary to lead a reasonable respectable life (all in the realm of ordinary definitions).

All communication activities therefore, have different goals. Hands on activities have more to do with the total communication of the technique or technology involved. It is closer to achieving objectives of somewhat like that of technology transfer. The first technology developed probably was the churning of fire. It may have been cooking food later. Many ages later it was the miraculous ‘wheel’. The objective of communication here was to quickly teach and train the ‘pupil’ to the somewhat equivalent level of the ‘tutor’. And, here lies all the difference. Hands on science, is the form of communication where knowledge deliberated by the source (tutor) gets transferred to the pupil without any degeneration loss.

Hands on science needs to be reemphasised in the modern nitty-gritty of complex procedures, techniques and methodologies. After all it has

been time tested tool during evolution of human civilisation all along.

## 2. Principle of ‘Communication Hierarchy Analysis’

Different forms of communication achieve different results. Sometimes it just provides information. This again can be amongst the peers or homogeneous groups or between two groups where one sits at the top of knowledge ladder and the other at lower levels. It is, at times possible that the first one derives a different perspective of the information, the other one derives totally different, sometimes diagonally opposite. Adoption of a new device in the automobiles to control pollution has different meanings for the group of environmental scientists and to an ordinary taxi driver. This difference in perspectives generated by way of communication makes way for various grades in communication tools, which is necessary for amalgamating communication with science having societal implications.

It is therefore thought prudent here to analyse communication tools on the basis of this hierarchy in impact and objectives; delivery and acquisition; and literacy and knowledge prerequisites.

While first order hierarchy should infer hierarchy in basic communication efforts, such as speech alone, or together with text, visuals, caricature, audiovisuals, graphics, etc., the other hierarchy can definitely be objective linked. Here elements deriving importance should be retention, impact, knowledge level, level of enlightenment, etc., objective linked hierarchy is associated with the objective aimed to be fulfilled while carrying out communication activity. The author proposes the principles and basis for ‘Communication Hierarchy Analysis’ to understand the selection of the type of media, objectives achievable against the subject being taken up for communication activity and its nature. Following classification satisfies this hierarchical understanding and the analysis following completes the process involved.

The Communication Hierarchy Analysis first of all involves defining the hierarchy as follows:

### (i) Dimensional hierarchy:

Verbal communication  
Written communication  
Visual communication (exhibits and displays)  
Audio-visual communication  
Hands on communication

### (ii) Objective linked hierarchy:

Information  
Appreciation  
Understanding  
Learning  
Total knowledge acquisition

### (iii) Subjective linked hierarchy:

Mass communication  
Science and technology mass communication and other specialised communication such as for children  
Expert peer group communication

The Dimensional hierarchy is the first order analysis and deals with the very obvious analysis in communication. Whereas verbal mode is the basic but it is most essential. It can reach to every kind of target mass and it can also be utilised to reach common and specialised target audience. At the top here we have Hands on communication, which leaves minimal knowledge difference level between the source and the target. The methodology adopted here ensures that almost every aspect associated with the subject of communication is transferred to the target. The application of this method needs to be chosen keeping in mind the effect and objective the communication exercise is required to fulfil.

The Objective linked hierarchy is analysis based on objectives achievable through the communication activity. Information may not require as deep involvement of all the acquisitive learning faculties of the target involved, Total knowledge acquisition on the other hand, requires greater involvement of learning faculties of the target. The results here are of highest order.

Subjective linked hierarchy analysis seeks its basis in the subject of the communication

activity. For mass communication the generalist strategy is put to use which takes note of some basic commonly understandable concept to be communicated. Vocabulary usage depends upon this common understanding of the target involved. Expert and peer group communication involves highly technical concepts and vocabulary in communication as 'expert' here becomes the 'generalist' (target). This group puts a lot of emphasis on the necessary skills and expertise of the communicator.

### **3. Science and technology communication**

This is specialised form of mass communication. There are some definite prerequisites necessary, which a communicator has to possess in order to prove to be successful in his task of communicating a science or a technology. It is specialised in this sense that you need to be specially equipped to understand it and then to communicate it effectively.

While talking of dimensional hierarchy vis-à-vis science and technology communication, it is better if we can use the higher hierarchy as a tool for communication. But we need to understand the complexity of the subject, i.e. Subjective linked hierarchy and the aim, i.e. Objective linked hierarchy. Complex the subject, i.e. possessing higher degree of hierarchy, difficult it becomes selection of the objective.

If you select higher degree of hierarchy in any of the two groups, then there are some prerequisites for the target to have already acquired in terms of the knowledge level associated with. This can very well be defined by the communicator involved. More importantly this can not be universal, every communicator has to evolve for his way of handling of the communication tasks and his expertise with the tools of communication to be put to use.

Technology communication in particular has another dimension. It is of transfer of technology. This is much more complex a task but relatively easy to carry out if all the requirements are met, as the 'source' and the 'receiver' both are in the highest state of effective 'transmission' and 'reception' of knowledge.

### **4. Technology: The great democratising force**

The above explanation can well be appreciated while understanding the nature of technology from the communicator's viewpoint. Technology is a great democratising force in the sense that the prerequisites of literacy and knowledge are even out with the skilful 'source' and highly willing 'receiver'. The target of receiver can be from very heterogeneous groups, yet they may acquire the knowledge in the realm of greatly close level of skill and reproducibility.

Understanding of technology, its appreciation and reproducibility is flexible in understanding from the 'receiver' point of view. Technology can be unconcerned of the level of literacy and scientific knowledge at times. This explains for the fact that technology arrived much before scientific understanding of it in human knowledge acquisition. This is strange in the intellectual order but quite relieving in practical scheme of things.

### **5. Hands on science: Achieving totality in communication**

We may like to analyse Hands on science in the light of the analytical tool proposed above. This is necessary for the application of such activity for its anthropogenic effectiveness.

From the viewpoint of Dimensional hierarchy, Hands on science stands at the highest level. This is for the reason that limitless dimensions can be involved while carrying out hands on activity. This relegates importance on the literacy related prerequisites associated with the communication process. Yet the result of communication is greater. Another important aspect discussed above being the level of uniformity in the knowledge received by the 'target' or 'receiver'. This very phenomenon calls technology as 'democratising force' as its knowledge for product (which is an application of technology) reproducibility is transferred irrespective of literacy and information skills.

In the realm of Objective related hierarchy, Hands on science again is placed at the top level as the objective achievable in this case is that of highest degree. Hands on activity can potentially make the target understand the science behind

the product and technology and can grant the skill of reproducibility to and amazing extent.

Hands on science activities can be applied to achieve goals of specialised communication. This is where some sort of limitation comes onto scene due to specialised requirements. For making this activity applicable for mass communication, great resources are necessary. But, with the emphasis on the kind of objectives achievable, it is worth undertaking it and adopting it as the ultimate tool for communication of all sorts of complex subjects.

This form of activity for achieving goals of communication including education at all levels lays a great emphasis on the skill and expertise of communicator-teacher-technologist as a knowledge 'source'. This can be tackled by developing appreciation, motivation and expertise in this field and amalgamating with appropriate communication skills of the communicating knowledge source..

## 6. Conclusion

Hands on science activity have some good advantages over other communication techniques, more so in specialised communication. The great compromise of literacy and knowledge level is only possible here. It has been put to test through Communication Hierarchy Analysis proposed here and found to be having many advantages. During the analysis that given the objectives and the subjective related hierarchy, the advantages involved with a particular subject are adequately highlighted. Hands on science activities are communication involving total knowledge transfer but the requirements on account of resources may put some limitation initially. Thus for a new subject, a mixed up approach may be necessary to meet the quick gains in near term goals. The efficacy of transfer of knowledge from source to receiver is amazing in this case and needs to be appreciated and put to effective use.

## 7. References

- [1] Flick Lawrence. The meanings of Hands-on science. *Journal of Science Teacher Education*; 1993. Vol. 4(1); pp1-8.
- [2] Sharma RD. Communication of science and Technology in ancient India. *Indian Journal*

of Science Communication; 2001. Vol. 1(1); pp 3-7.

---

---

## Hands-on Universe–Europe

R. Ferlet

EU-HOU Team. Institut d'astrophysique de  
Paris, CNRS/UPMC  
98bis Bd. Arago, 75014 Paris (France)  
ferlet@iap.fr

**Abstract.** The European Hands-On Universe (EU-HOU) is aiming at motivating for science middle and high school pupils by bringing frontline interactive astronomy to the classroom through new technologies. It relies on real observations and pedagogical resources usable through a dedicated software. The project includes now 14 European countries and focuses on teacher training. It was awarded in 2009 the silver medal of the European Commission in the category Creativity and Innovation in ICTs for Education and Lifelong Learning.





## AUTHOR INDEX

### A

Adi V.K. [333]  
Agarwal A.K. [305]  
Ahmad S. [323, 353]  
Ahmed T. [243]  
Akram D. [323]  
Allemandi W. [83]  
Almeida-Soares A.R. [347]  
Andrei L. [230]  
Ansari M.A. [243]  
Aram I.A. [299]  
Arif J.M. [129]  
Arora A. [293]  
Arvanitis M. [187]  
Ayres de Campos J. [193]

### B

Bachmann L. [24]  
Banerjee G. [139]  
Berezovska I. [175, 301, 303]  
Beteringhea A. [342]  
Bhattacharyya R.K. [165]  
Bhavisha P.S. [45, 57, 220]  
Borah B.B. [358]  
Borah D. [358]  
Borwar S.S. [205]  
Buchinger K. [175, 303]  
Busa R. [230]  
Bute S.J. [292]

### C

Carreira-Leal S. [161]  
Carvalho L. [354]  
Chandra K.S. [180]  
Chaudhari A.S. [157]  
Chaudhari S.A. [214]  
Chaudhary S.K. [99, 123]  
Cheng-Ming T. [253]  
Chhaya L.K. [257]  
Chien Ho Chou [341, 342]  
Chin Hsin Huang [341, 342]  
Ching-Chi Chu [301, 302, 343]  
Chin-Hsueh Rd [325]  
Chirose-Horie C.A. [83]  
Chisleag Losada I.R. [144]  
Chisleag R. [144]  
Chung-Chih Chen [325]  
Cimpoca F. [230]  
Costa M.F.M. [89, 152, 193, 198, 210, 304, 326]  
Costa-Ramalho A. [347]  
Couto Maia F. [234]

### D

Das A. [291]  
Das S. [254]  
D'Cruz L. [351]  
Devi N. [348]

Dhingra V. [267]  
Divjak S. [53]  
Diz-Bugarín J. [40]  
Dorrio B. V. [89]  
Dutta A. [60, 275]

### E

Enache M. [230]  
Erdogan M. [311]  
Erentay N. [311]  
Erol M. [300]  
Esteves Z. [210]

### F

Fatima N. [30]  
Ferlet R. [379]  
Fernandes J.F. [304]  
Florin Z. [351]  
Floros A. [187]  
Fonseca R. [304]  
Franco S. [193]

### G

Garg A. [267]  
Gaurav Papnai [236]  
Gheorghe B. [351]  
Ghoderao S. B. [328]  
Ghosh S.S. [225]  
Ghuge C.S. [205]  
Gurunadha-Rao V. [335]

### H

Hsiao-Ching Su [301, 302, 343]  
Human I. [364]

### I

Ionian T.V. [187]  
Ionita I. [342]  
Iyamperumal P. [31]

### J

Jabapriya T. [110]  
Jayaprakash D. [115, 325]  
Jogi V.R. [346]  
Jokhakar V.N. [50]  
Jolly M.K. [359]  
Joshi D. [318]  
Junghare A.R. [205]

### K

Kala L. [376]  
Kalaiyarasi R. [353]  
Kamal A. [30, 129]  
Kamalesh N. [180]  
Kankariya R.D. [328]  
Kaohsiung Hsien [325]  
Kashif M. [353]  
Kaur B. [146]  
Khambayat R. [205]

Khan R. [364]  
Khan Z. [267]  
Kshirsaga V. [205]  
Kumar A. [267]  
Kumar G.P. [353]  
Kumar H. [146]  
Kumar P. [355]

## L

Lad H.J. [157]  
Lahane R.D. [343]  
Lakshmanan S. [353]  
Leal J.P. [161]  
Leite-Dutra J.A. [71]  
Lewenstein B.B. [10]  
Lira M. [193]

## M

Machado C. [326]  
Machado-Ribeiro A.S. [234]  
Maji T.K. [348]  
Manikandan A. [353]  
Martinho M. [304]  
Mateiciuc A.D. [342]  
Mehrotra R. [255]  
Mishra M. [351]  
Mohapatra B. [365]  
More P.S. [205]  
Mostaço-Guidolin L.B. [24]  
Mousas C. [187]  
Muthukumar R. [353]

## N

Nandi K.K. [295]  
Narasimham N.A. [356]  
Niculescu-Mizil [342]  
Nogueira M.I. [83]

## O

Oliveira e Sá S. [152]  
Oliveira Pinho D.A. [347]

## P

Padmaja A. [291]  
Padmavathi B. [291]  
Pandey K. [247]  
Pandi A.S. [367]  
Pandya P. [318]  
Parmar A. [146]  
Patairiya M. [1]  
Patel S.V. [247]  
Pathare S.R. [343]  
Pati P. [150]  
Pereira da Silva J.M. [234, 271, 347]  
Pereira dos Santos M.A. [152]  
Pereira-Coutinho C. [198, 326]  
Pereira-Couto R.S. [234]  
Perera S. [134]  
Pinner R. [323]

Prabhakar A.M. [170]  
Prabhakar I. [236, 243]  
Puri S. [146]  
Purohit R. [235]

## Q

Qiao S.U.N. [361]

## R

Rajan M.A.J. [294]  
Rajput A.S.D. [352]  
Rangachar B [78]  
Rathod V.R. [247]  
Ray A. [60, 275]  
Ribeiro A.F. [15]  
Ribeiro C.R. [198, 326]  
Ribeiro N. [354]  
Rocha Afonso L.P. [71]  
Rodríguez-Paz M. [40]

## S

Sahingoz R. [300]  
Saiote J. [354]  
Sampath K. [367]  
Sanches-Diniz A.C. [71]  
Santos J.P. [304]  
Santos-Silva F. [354]  
Sanyal D. [139, 291]  
Sarma G. [358]  
Sarmah J.K. [324]  
Sasek-Divjak M. [94]  
Saxena J. [324]  
Seixas S. [304, 322]  
Shah T. [154]  
Shankar G. [130]  
Sharma R. [267]  
Sharmin E. [323]  
Shelke A.V. [205]  
Shibi I.G. [302]  
Singh P. [355]  
Siri D. [356]  
Sitamoto C. [83]  
Sitamoto S. [83]  
Stafeef S.K. [349]  
Stefureac C. [39]  
Sugumar R.W. [110]  
Surya Rao K. [350]  
Szepesi M. [39]

## T

Ta-Liao Hsiang [325]  
Thaddeus A. [294]  
Thakur A.J. [254]  
Tomilin M.G. [349, 355]  
Trna J. [105]  
Trnova E. [105]  
Tsong-Cean Tu [301, 302, 343]

**U**

Ubalel A.U. [205]

**V**

Valeriu D. [351]

Venkatesan S. [353]

Venkateswararao A. [224]

Verma S.R. [322]

Vibhuti M.J. [45, 57, 220]

Vin Son Hsieh [341]

Viralkumar B.M. [45, 57]

Vladu D. [230]

Vrinda S.T. [45, 57, 220]

Vyas P.C. [263]

**X**

Xue-Hui L.I. [361]

**Y**

Yadav R.S. [357]

Yan-Qing F.U. [361]

Yogesh M.B [45, 57, 220]

**Z**

Zafar F. [323, 353]

Zareeen Ahmad I. [30, 129]

Zhi-Sheng L.I.U. [361]







The Hands-on Science Network acknowledge these sponsorships and collaborations

