

Atividades musica de 14 o 30 abril 1º curso

- Recordamos os instrumentos de percussão
Deixamos e coloramos.

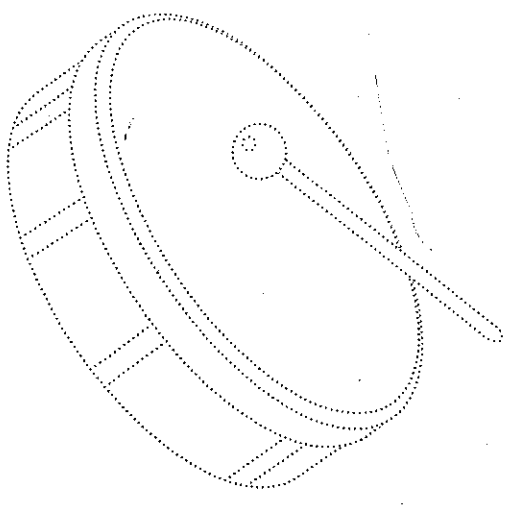

pandeiros

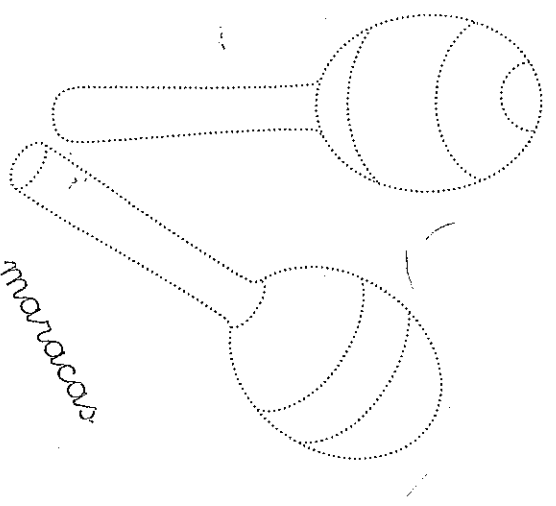

maracas

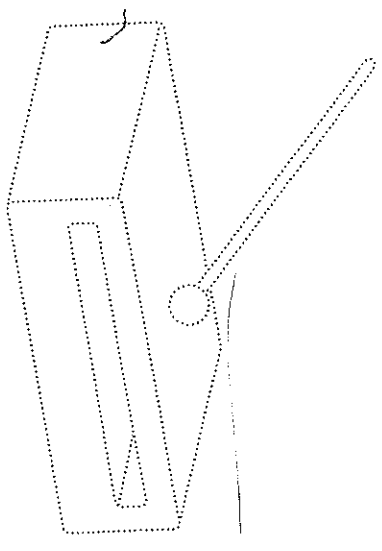

caixa chinesa

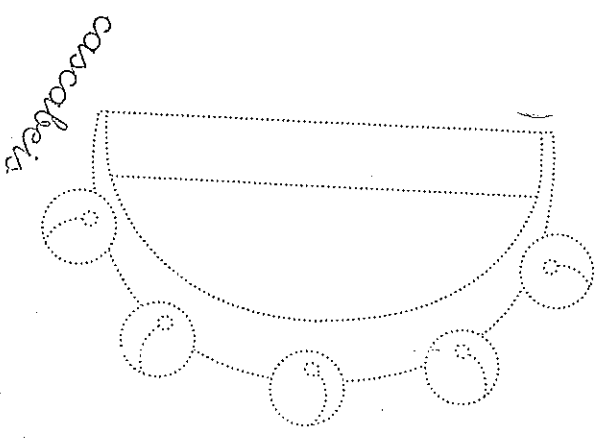

cascabels

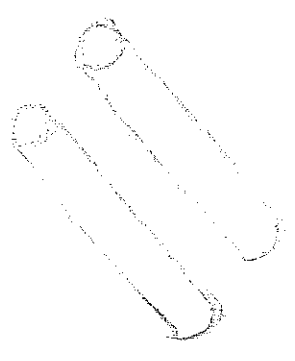

claves

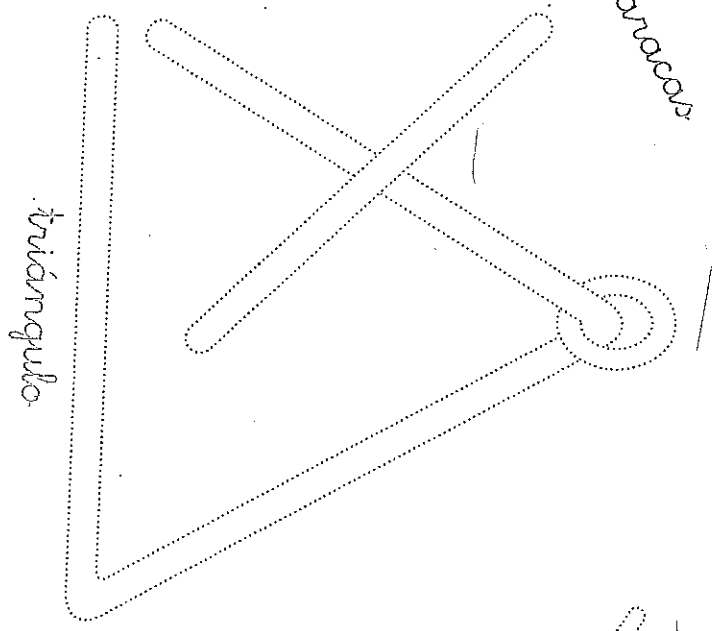

triângulo

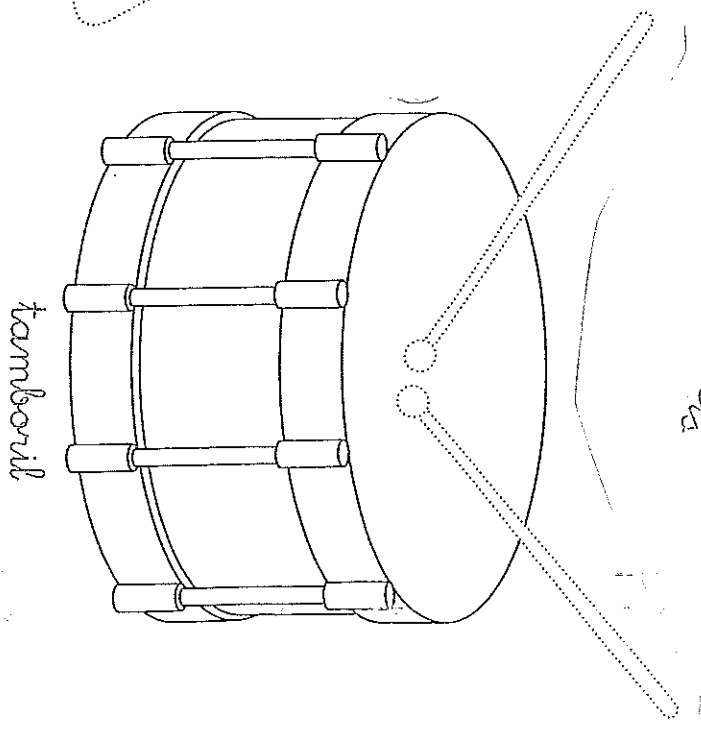

tamboril



A clave de sol serve para nomear as notas no pentagrama.
Colócase ao principio do pentagrama.

1 Repasa a clave de sol.

A row of five musical staves. Each staff contains a dotted treble clef for tracing. The first staff has a small '1' and an arrow pointing to the top of the circle. The second staff has a small '2' and an arrow pointing to the top of the circle. The third staff has a small '3' and an arrow pointing to the top of the circle. The fourth staff has a small '4' and an arrow pointing to the top of the circle. The fifth staff has a small '5' and an arrow pointing to the top of the circle.

A row of five musical staves, each containing a dotted treble clef for tracing. The staves are identical to the ones in the previous block.



Recordamos

Linguaxe musical. A negra e o seu silencio

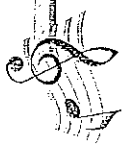

Utilizamos estes signos para escribir música:

a negra

o silencio de negra

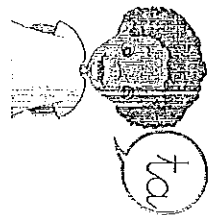

cabeza =>



← plica

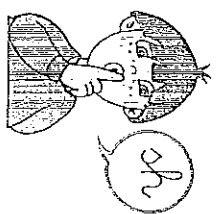
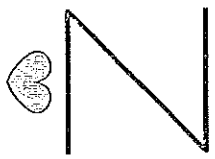

A negra dura un pulso. O seu silencio tamén.

1 Debuxa as cabezas e colorea.

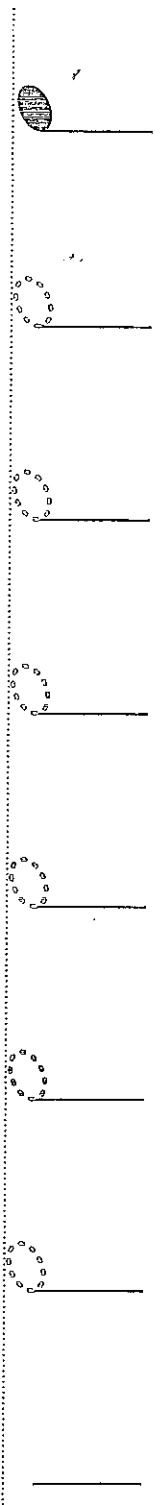

2 Debuxa as plicas e colorea as cabezas.

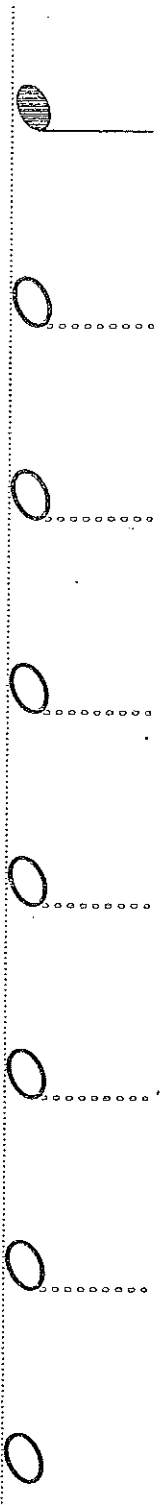

3 Practica a escritura do silencio.

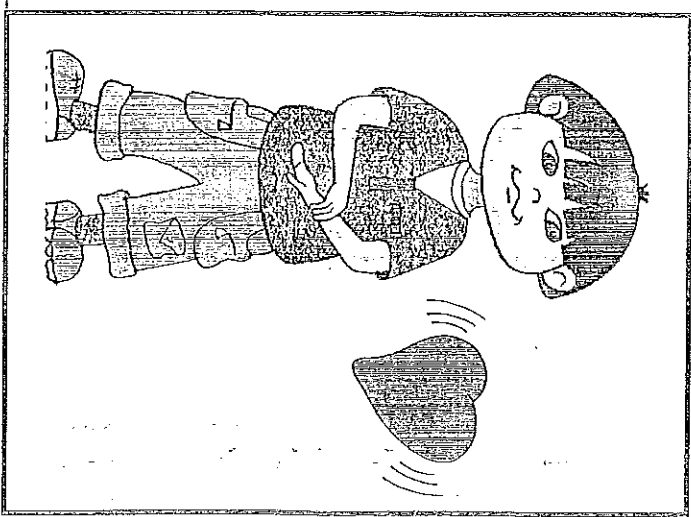



Linguagem musical: As cordheas

Recorrendo

Aparella de cordheas dura igual que unha negra.

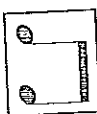
Cando duas cordheas non seguidas pódense escribir separadas  ou xuntas .

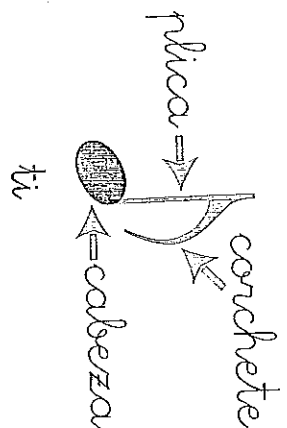

unha cordhea

duas cordheas

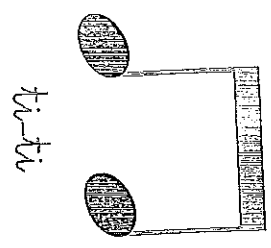

1 Preparar as cordheas e practica estes ritmos.

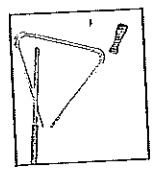

2 Completa o seguinte ritmo. Practica coa voz e con percusión corporal!

ta sh ta ti - ti ti - ti ta ta sh