

SISTEMAS de SAIDA de AUDIO para AUTOMÓBIL

Xullo Xermade

miscelánea



CAFI

Compostela 2013

Xornadas de Transporte e mantemento de vehículos

RANGO DE ESCOITA HUMANO

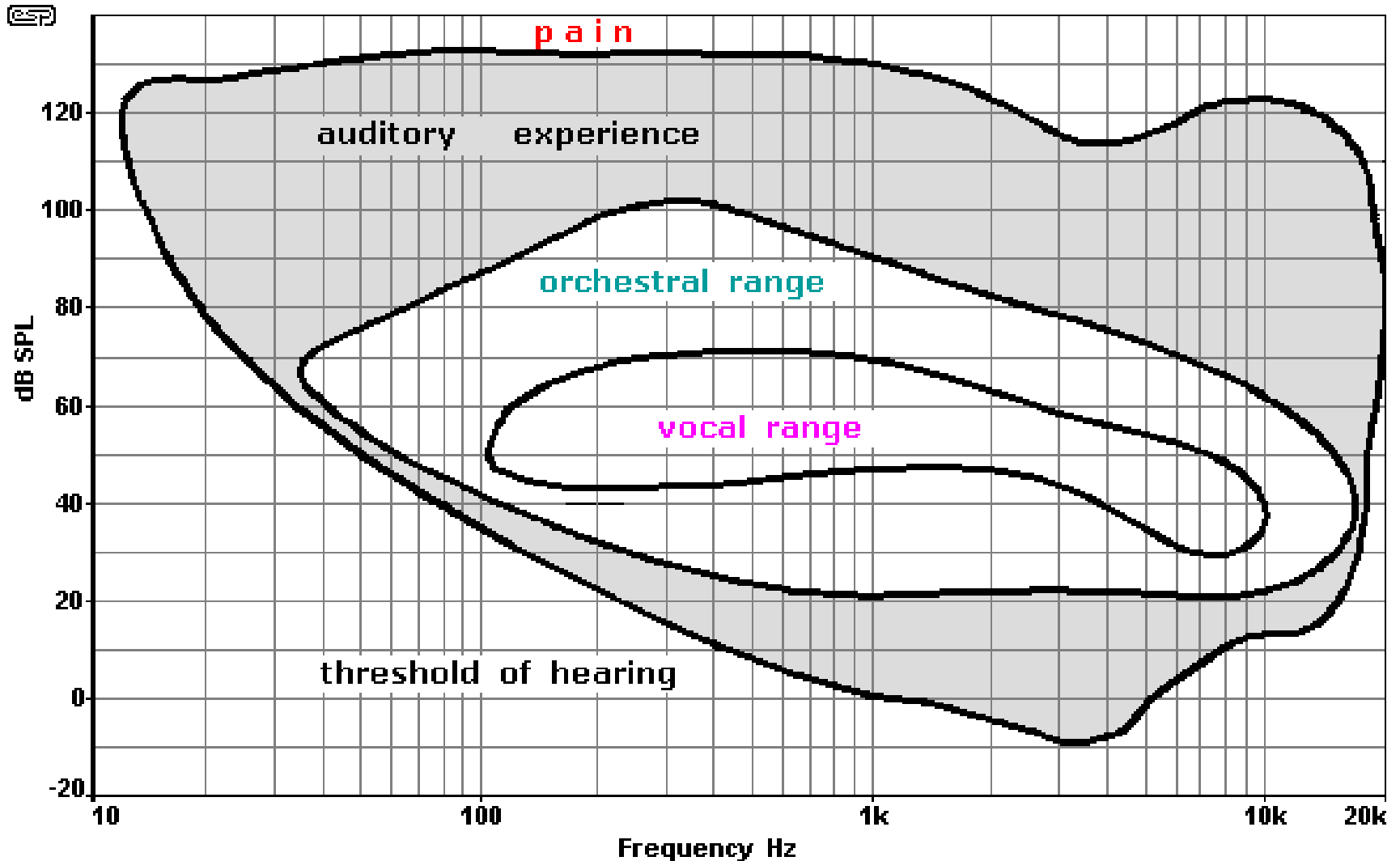

POTENCIA, RENDEMENTO E SPL

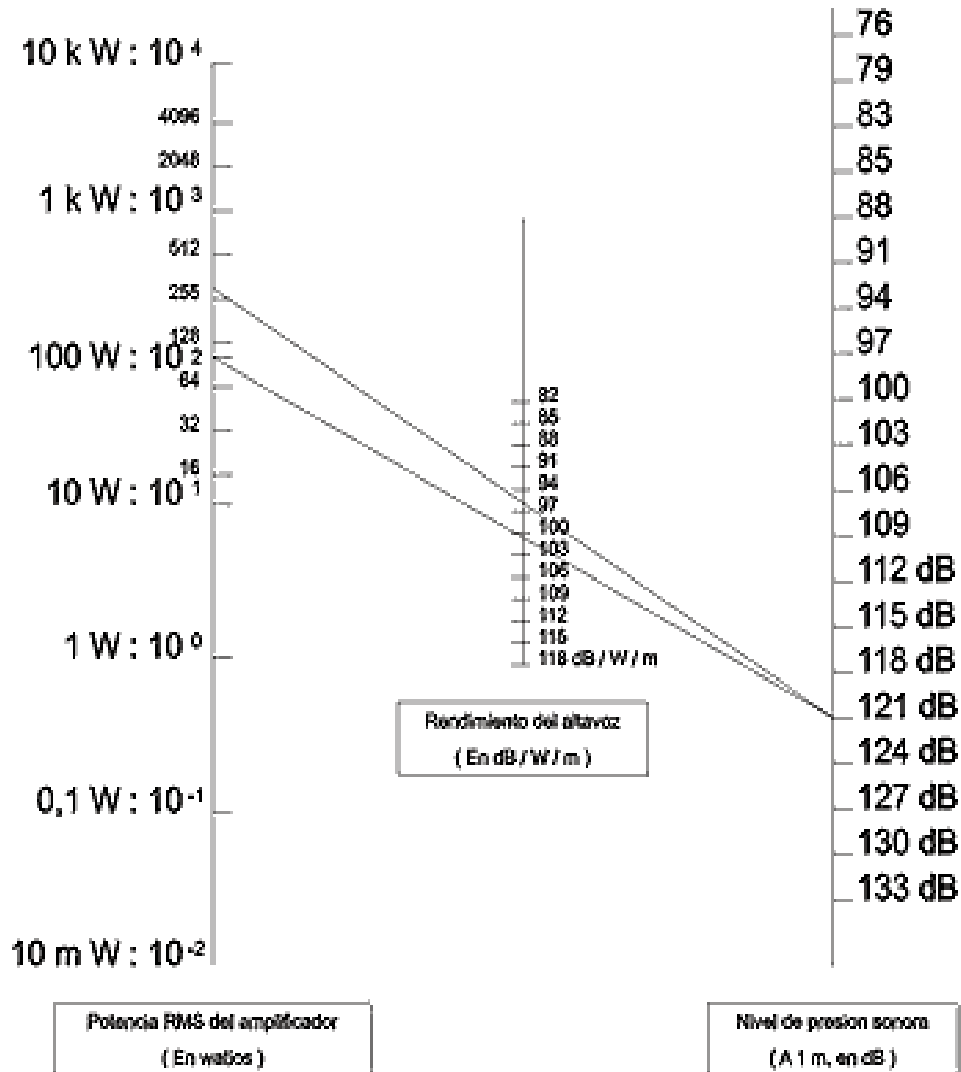

REPARTO DE ENERXIA nas VIAS

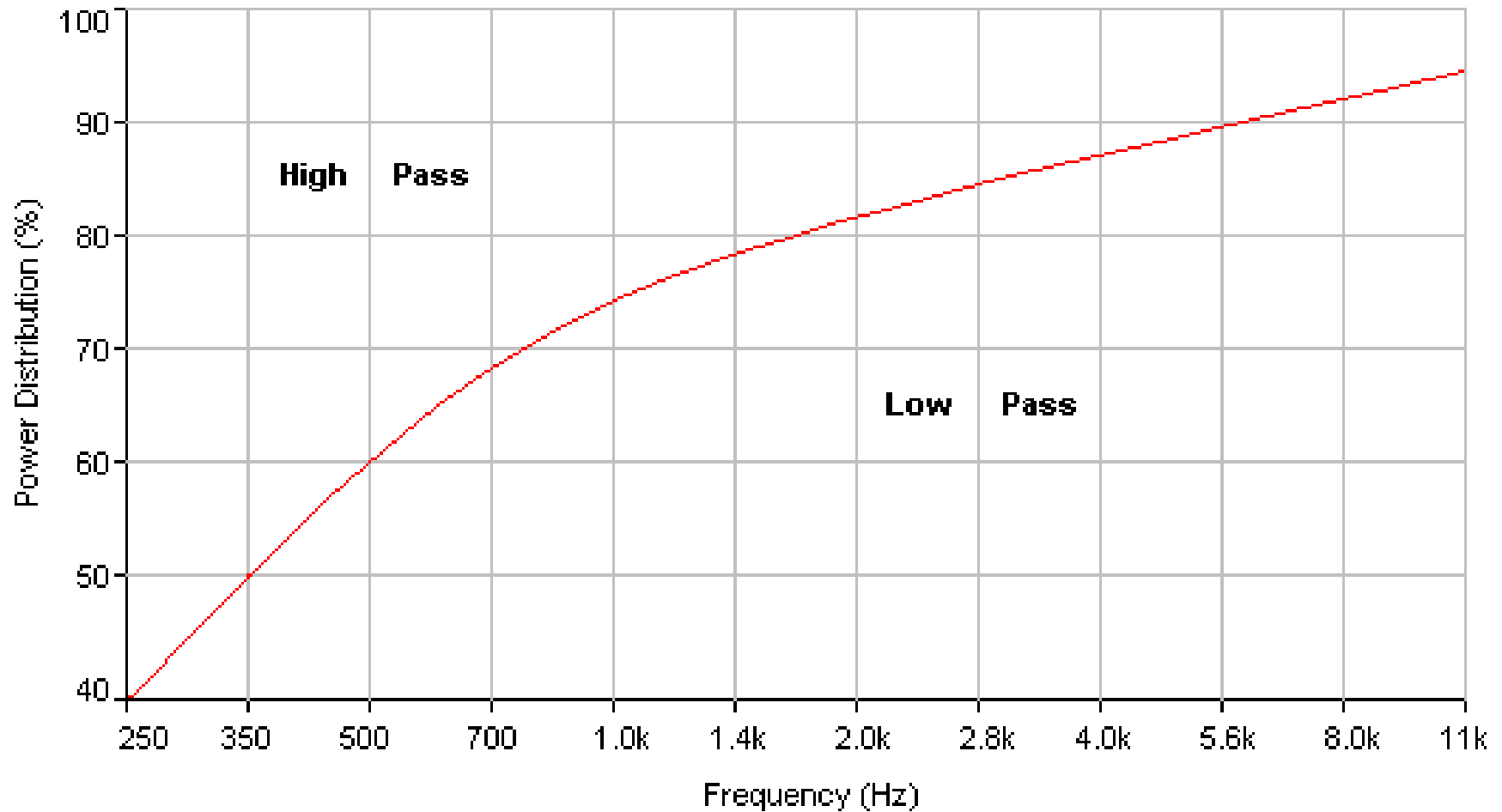

Tipos de PENDENTE

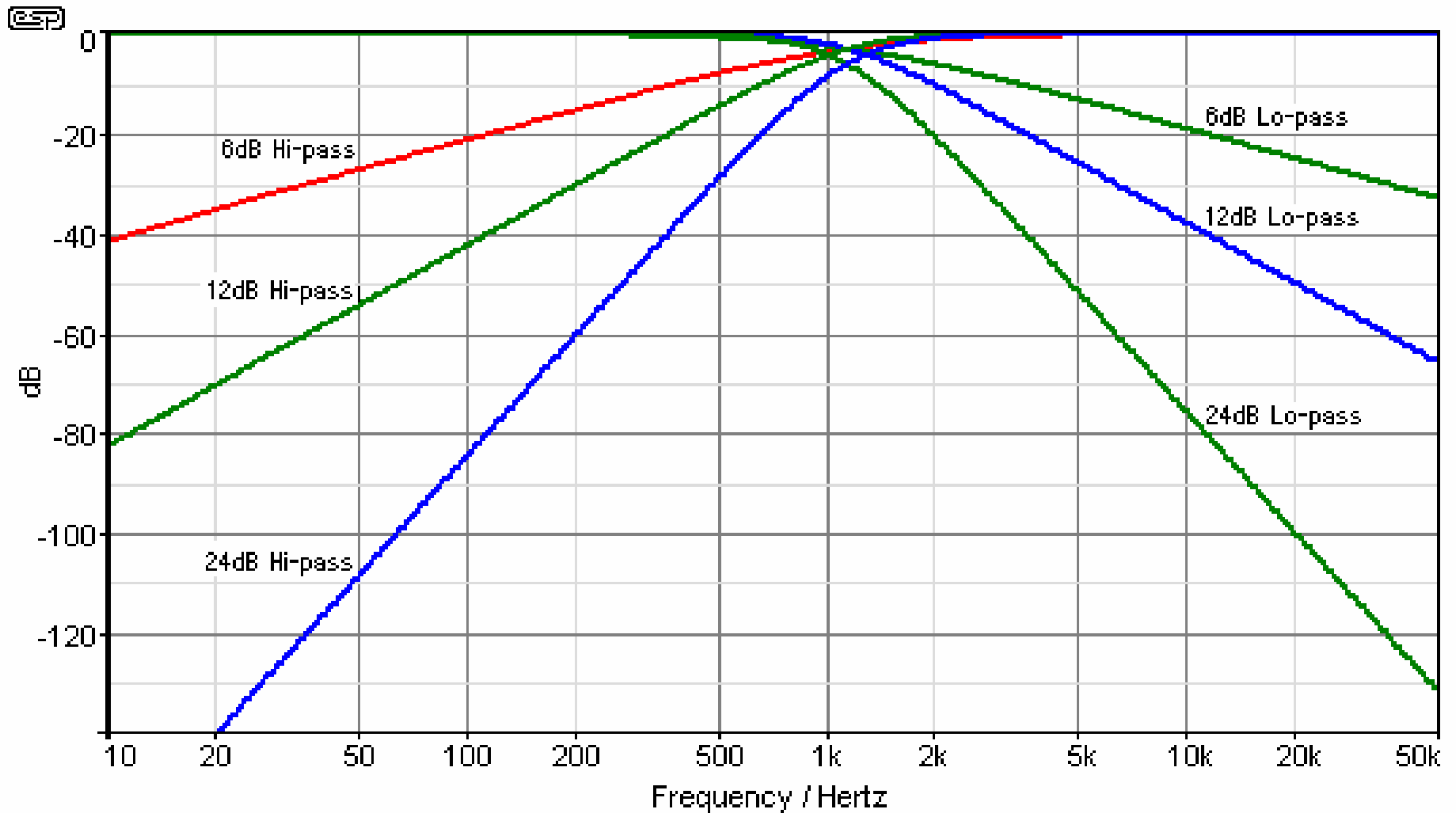

Typical Filter Slopes

1°, 2°, 3°, 4° orden

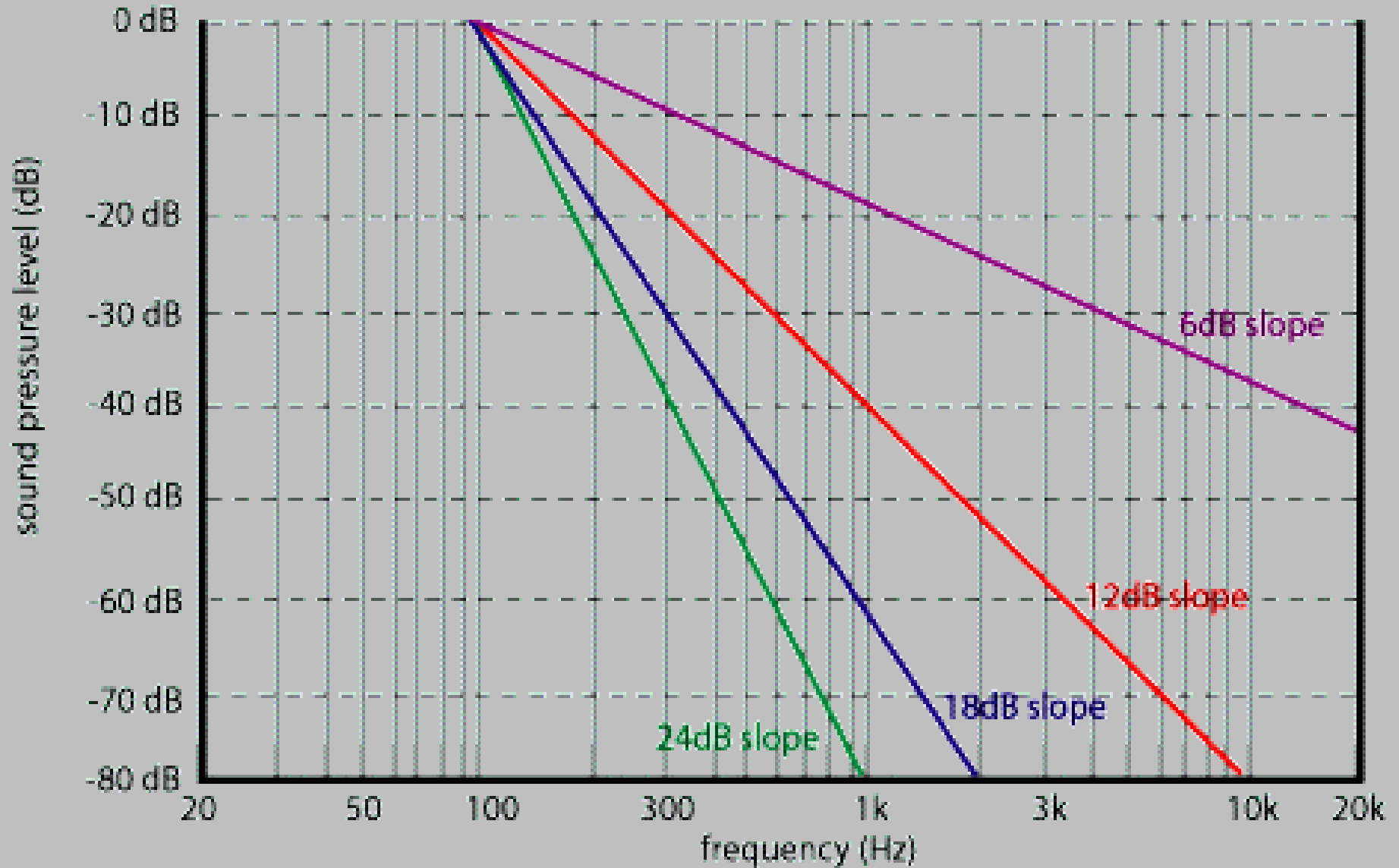

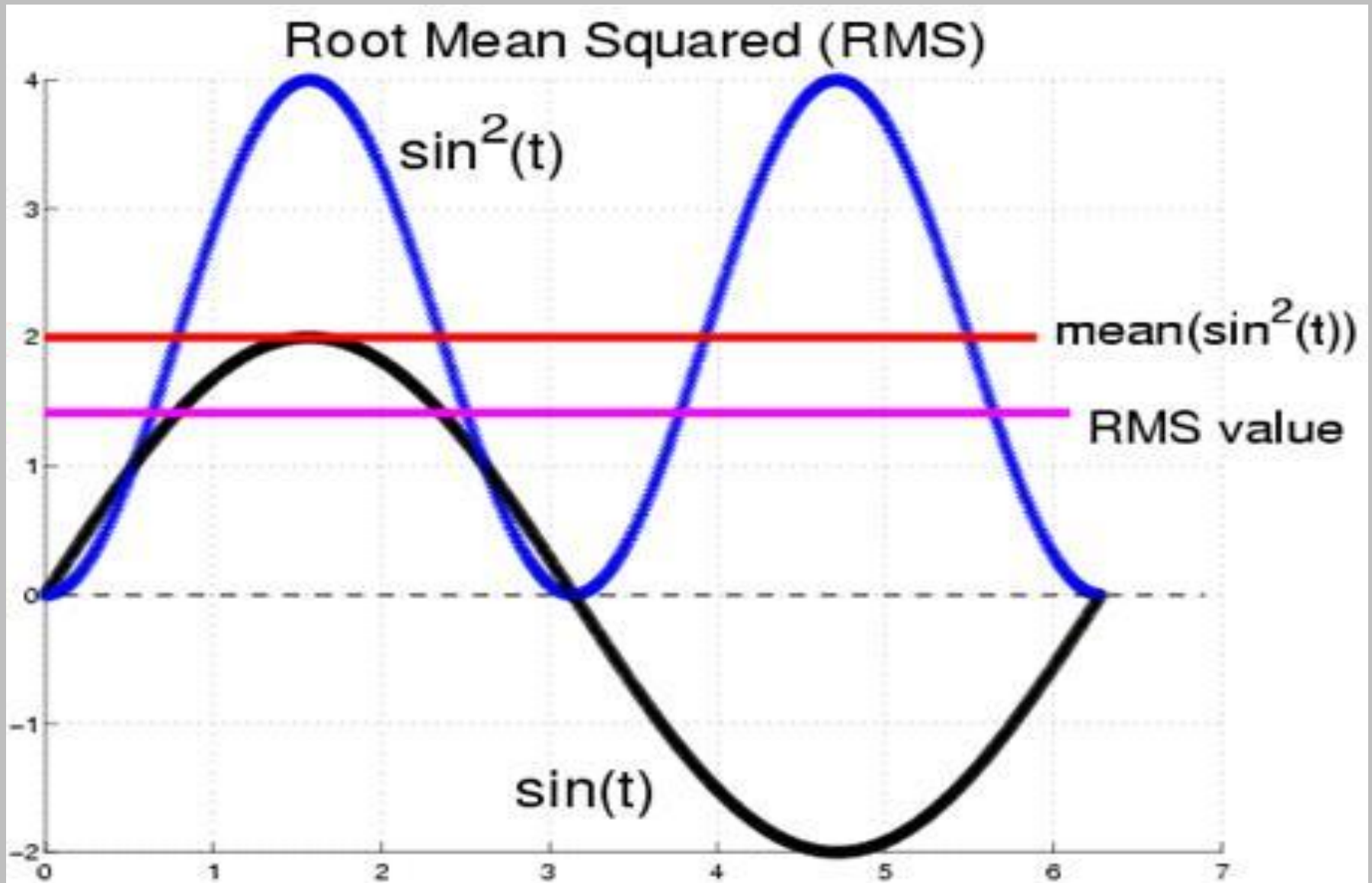

Tipos de INSTALACIONES de CAR AUDIO

SISTEMAS SQL (Sound Quality Level)

Objetivo a calidade do son. Búscase unha armonía entre todos os compoñentes da instalación tratando de lograr a maior calidade sonora posible

SISTEMAS STREET, STREET BASS , STREET LIGHT / EXTREMO:

Búscase un volumen elevado sen perder moita calidade de son

SISTEMAS TRIO ELECTRICICO :

Basicamente son para exterior, utilizando como configuración woofers, drivers de medios e tweeters.

SISTEMAS SPL (Sound Pressure Level),

Nivel de presión sonora. Non se busca calidade de son senon que os baixos teñan moitos dB. Predominan os subwoofers.

Debe plantexarse que son sistemas de alto risco e contaminación sonora.

Market Shares of Global Automotive Audio System Manufacturers, 2008

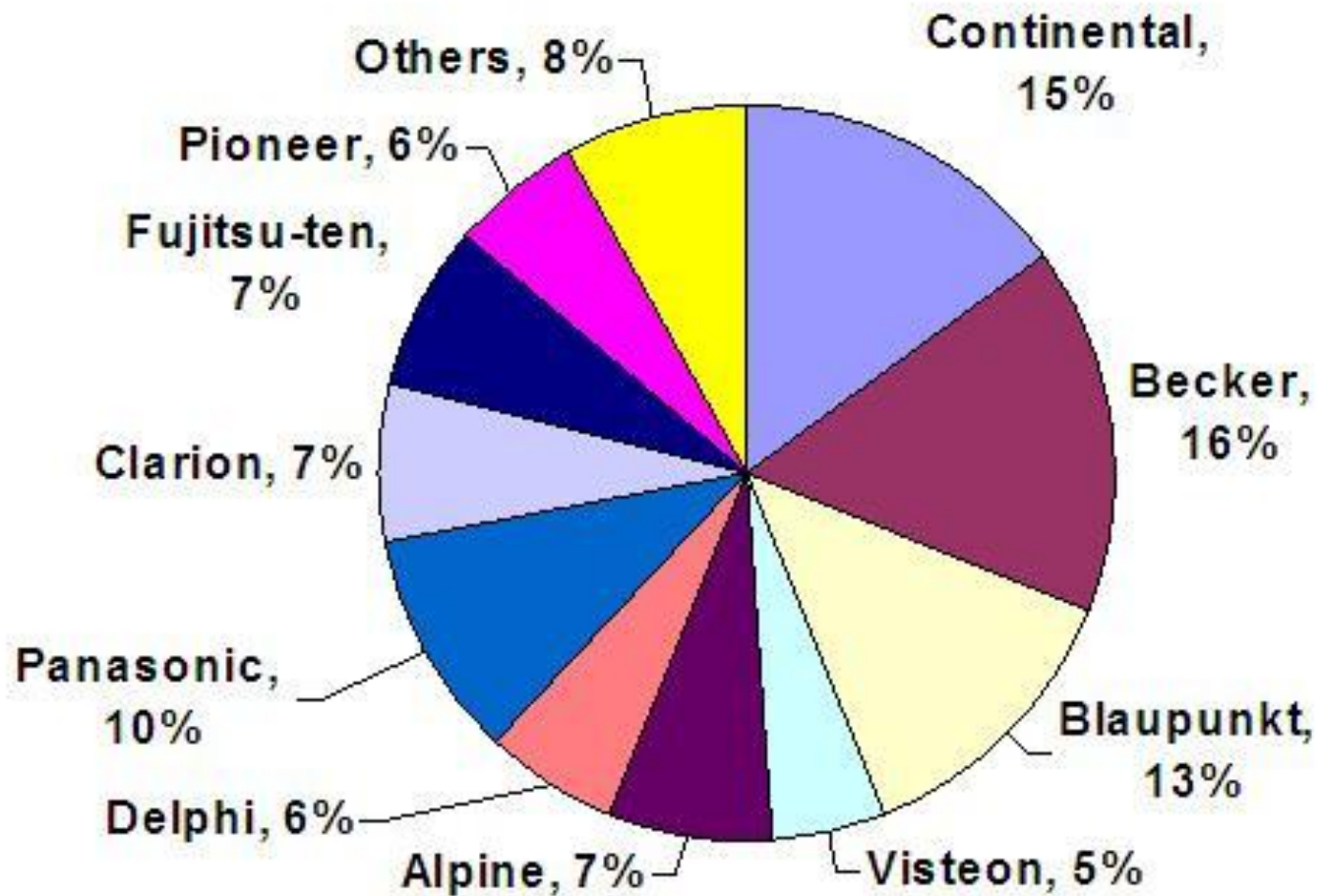



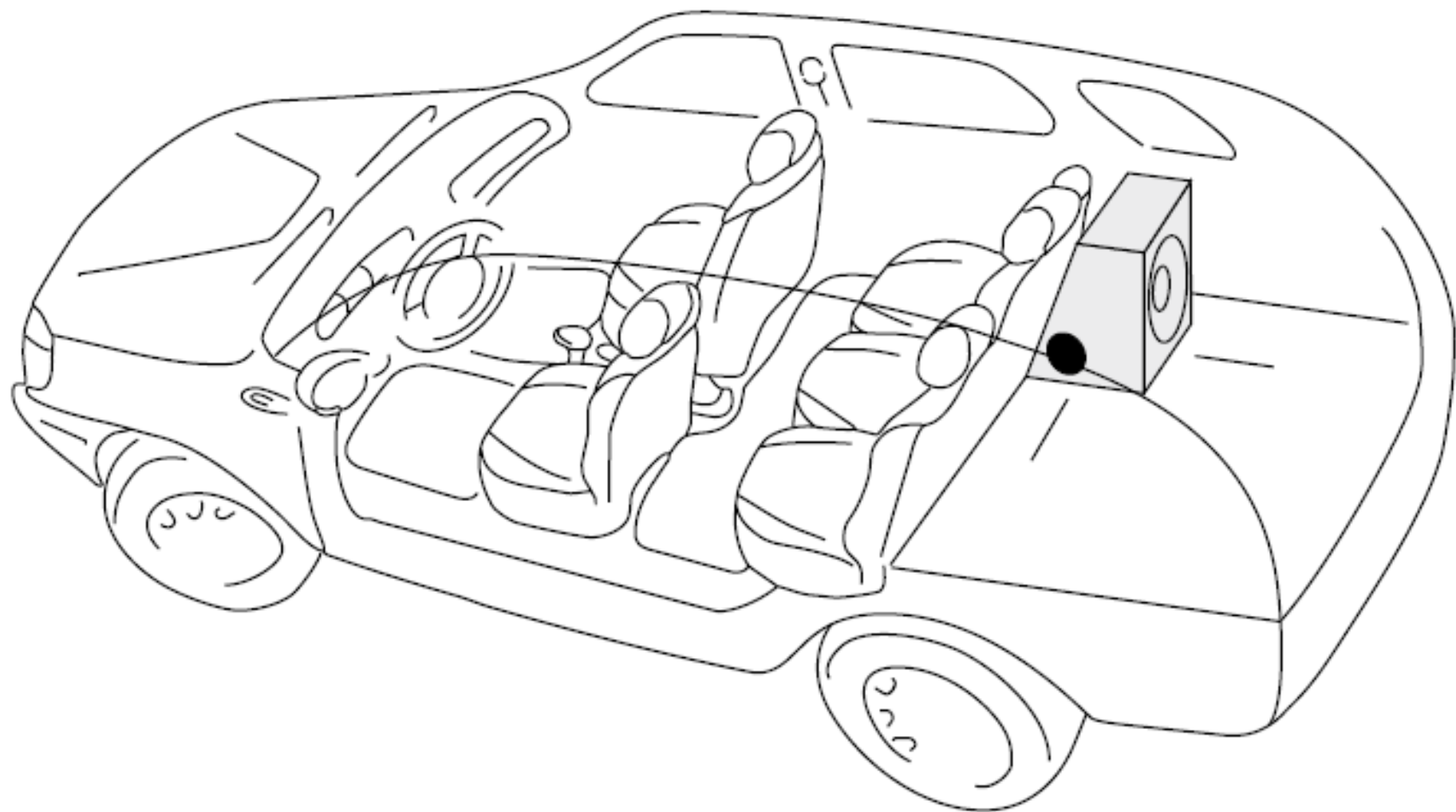



Battery and power to amp (ground)

Radio and wires from radio to amp

Amp

10" Sub and wires to sub

Speakers and wires to speakers

- Stock head unit
- JL 500/5 amp
- Boston SR60 component front speakers
- Polk 651 rear speakers
- Alpine S10 10" sub (spare tire mounted)

Sportage 6-Speaker
Stereo

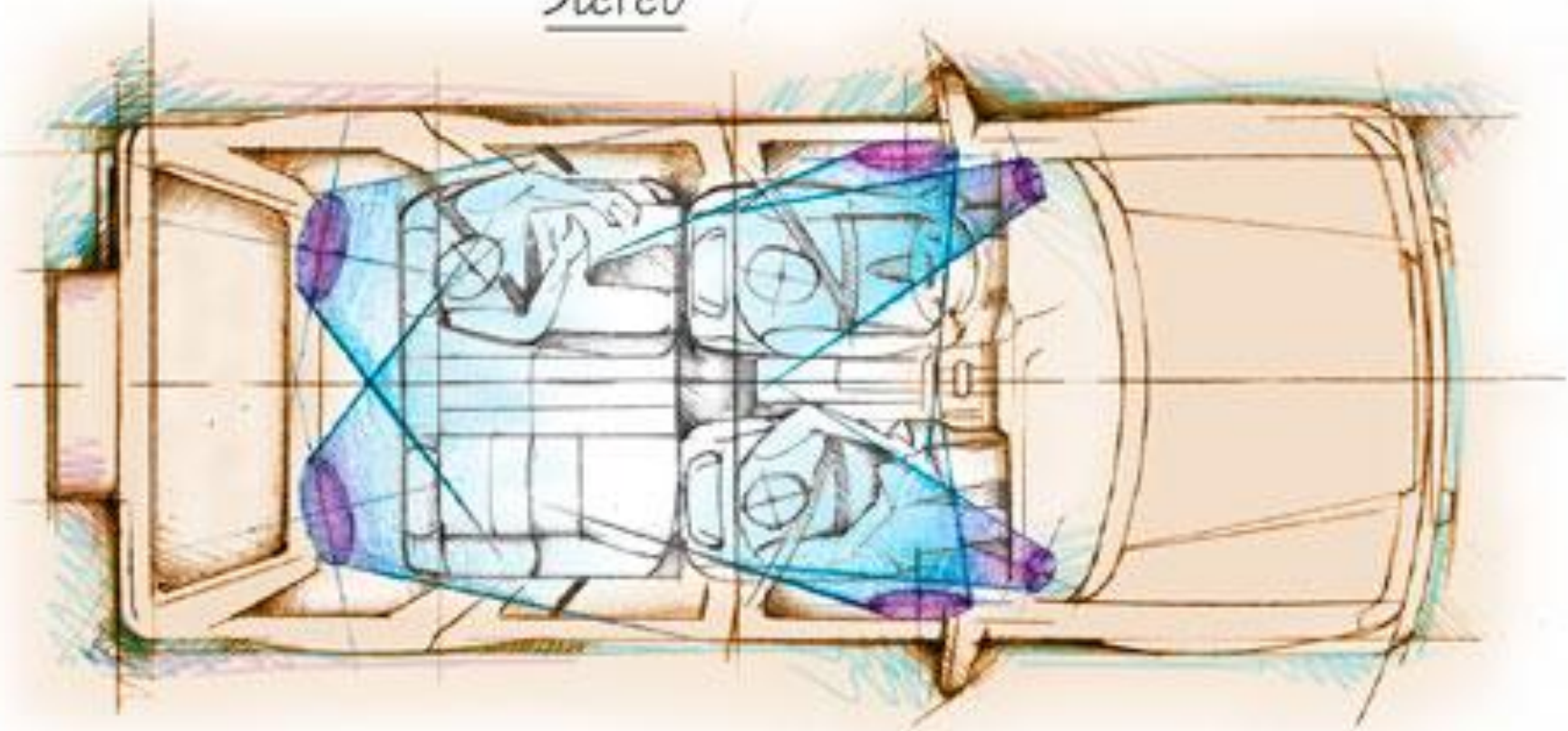

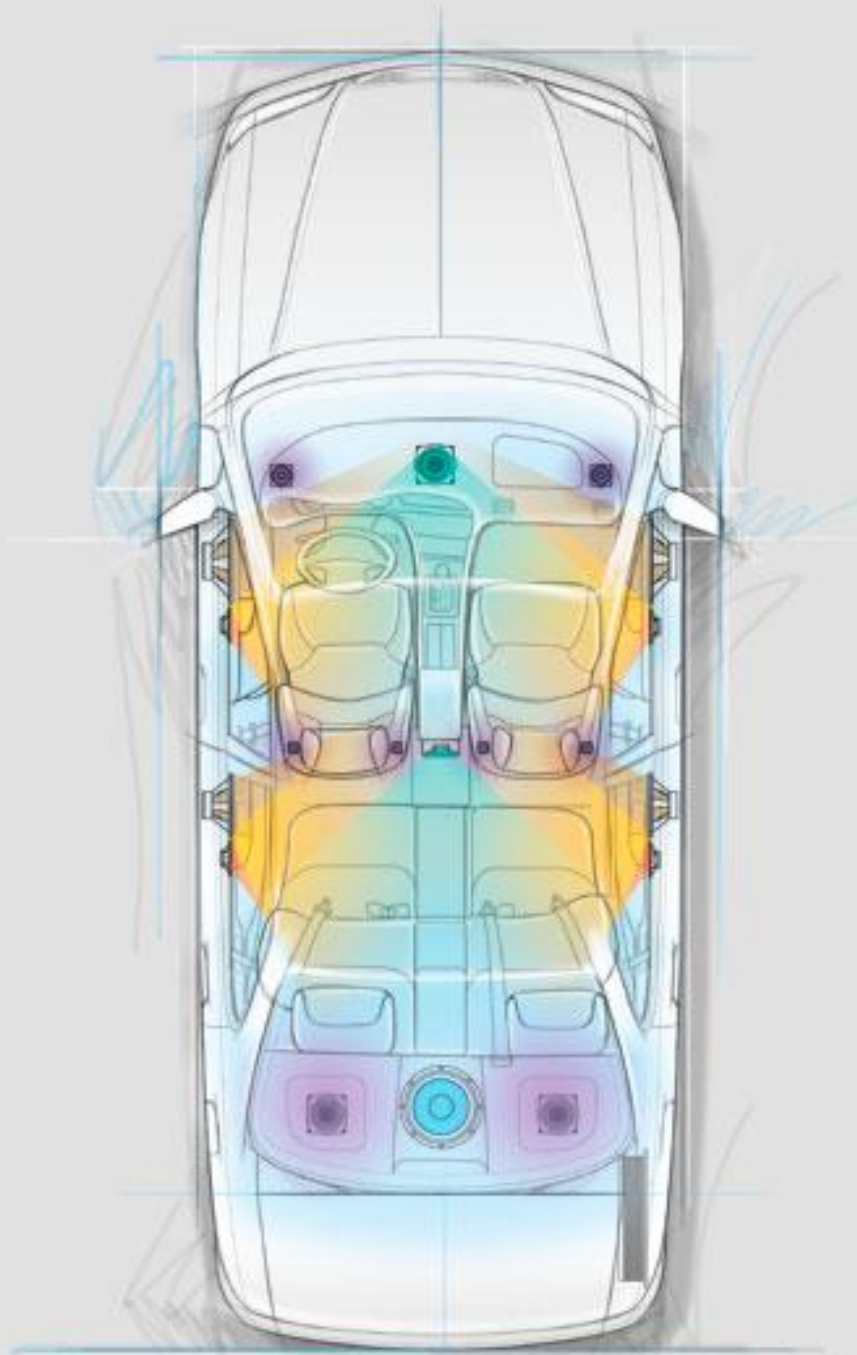

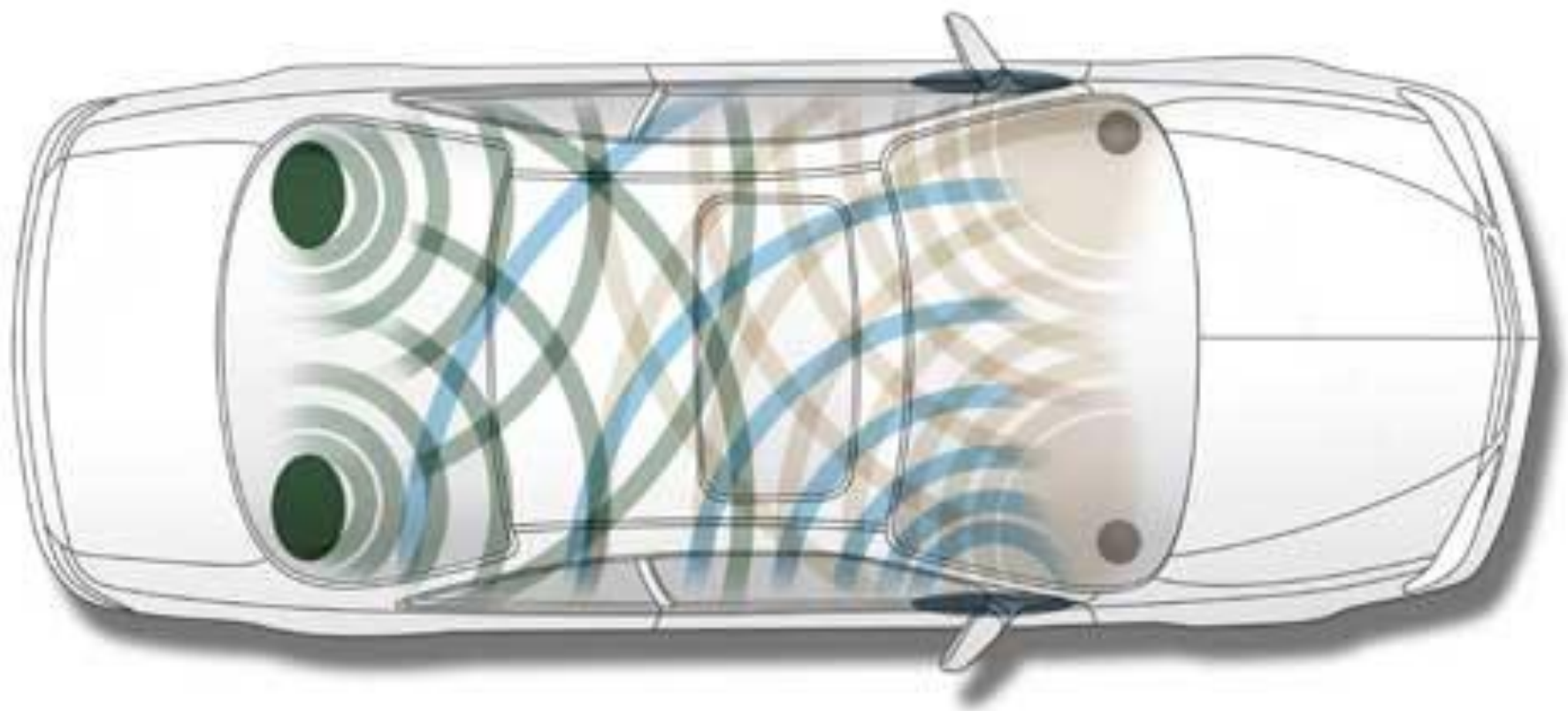

Sound stage

Eye Day Seat Gun

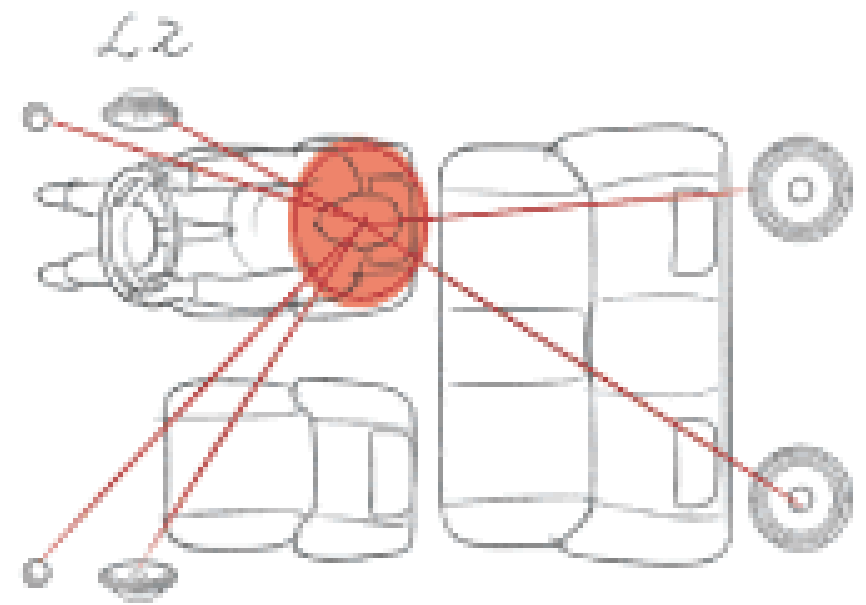
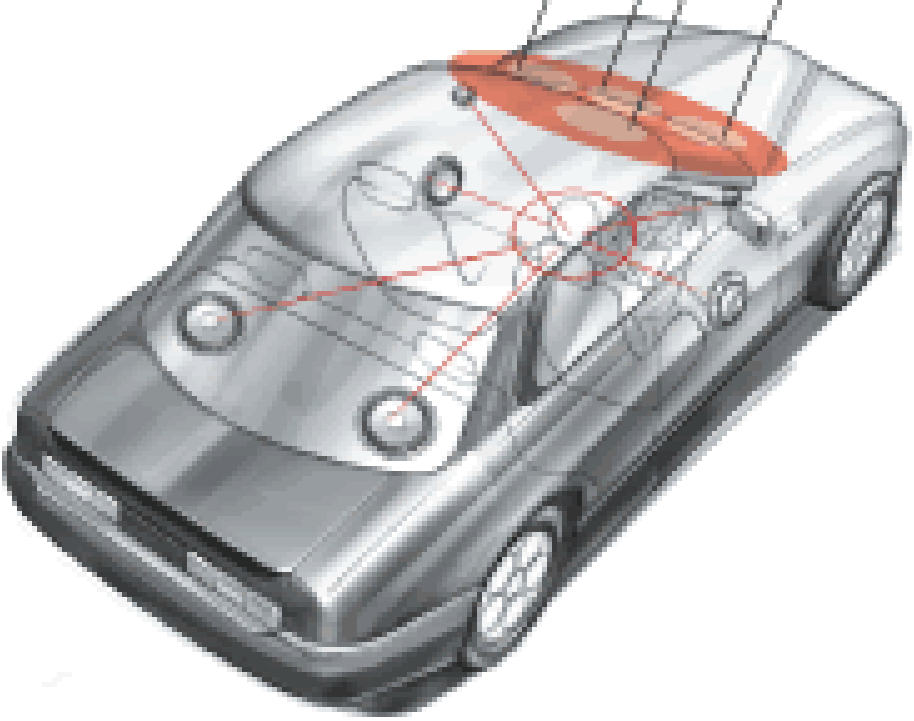

L1

Attainment time

Audi Sound Concept Uses 62 Speakers

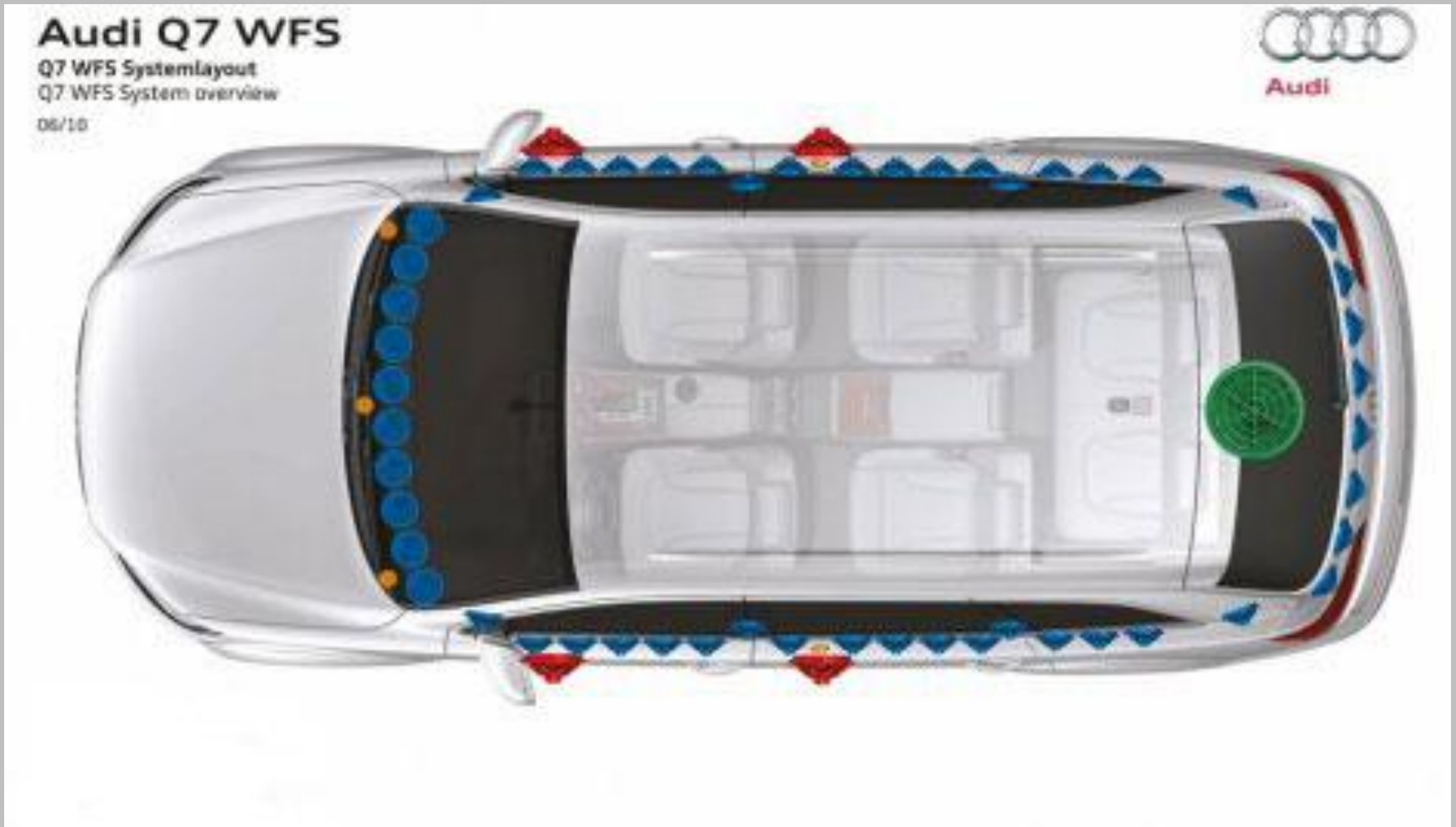

Using five woofers, five tweeters and 52 midrange speakers



**GRACIAS
POLA
ATENCIÓN**