

HFM7 Aerodinámica optimizada

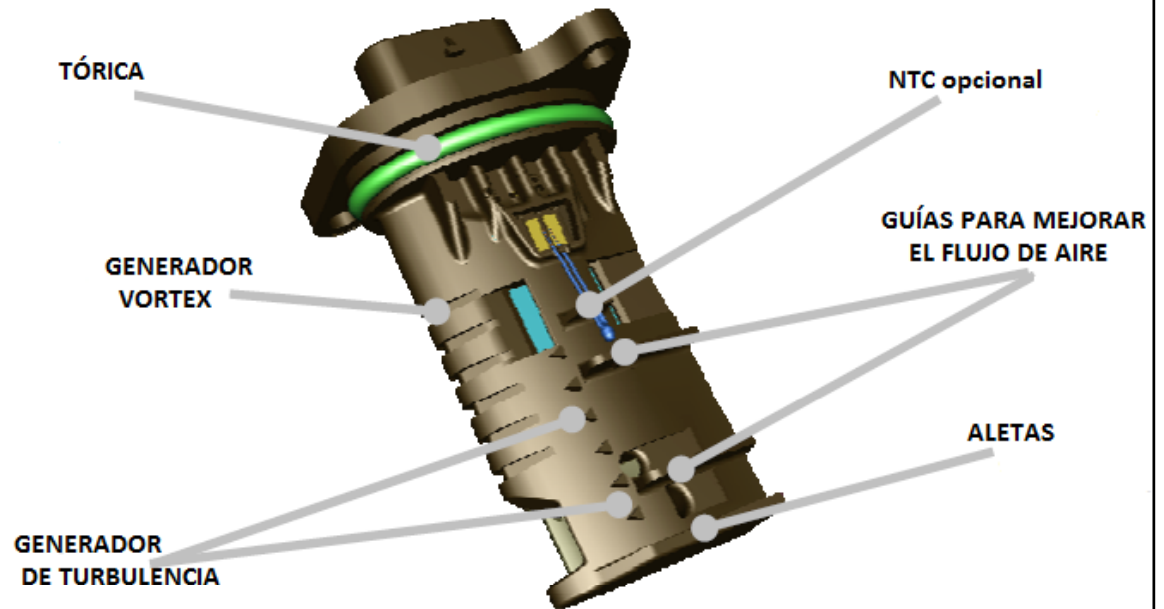

HFM7

Detalle del bypass HFM7 IP

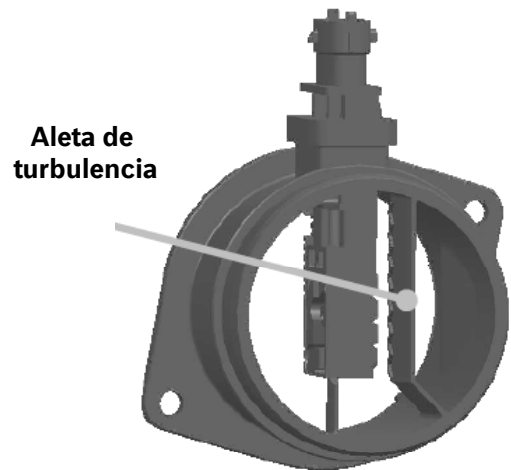
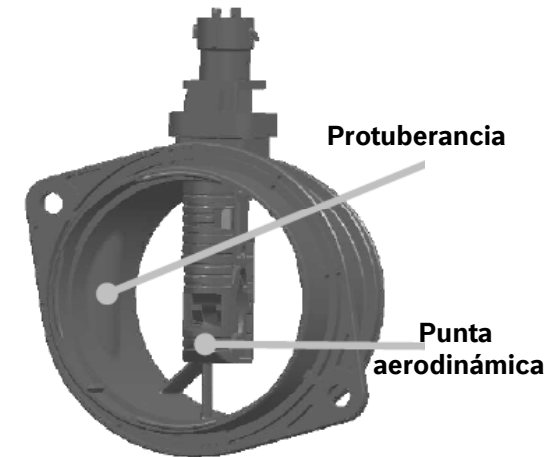
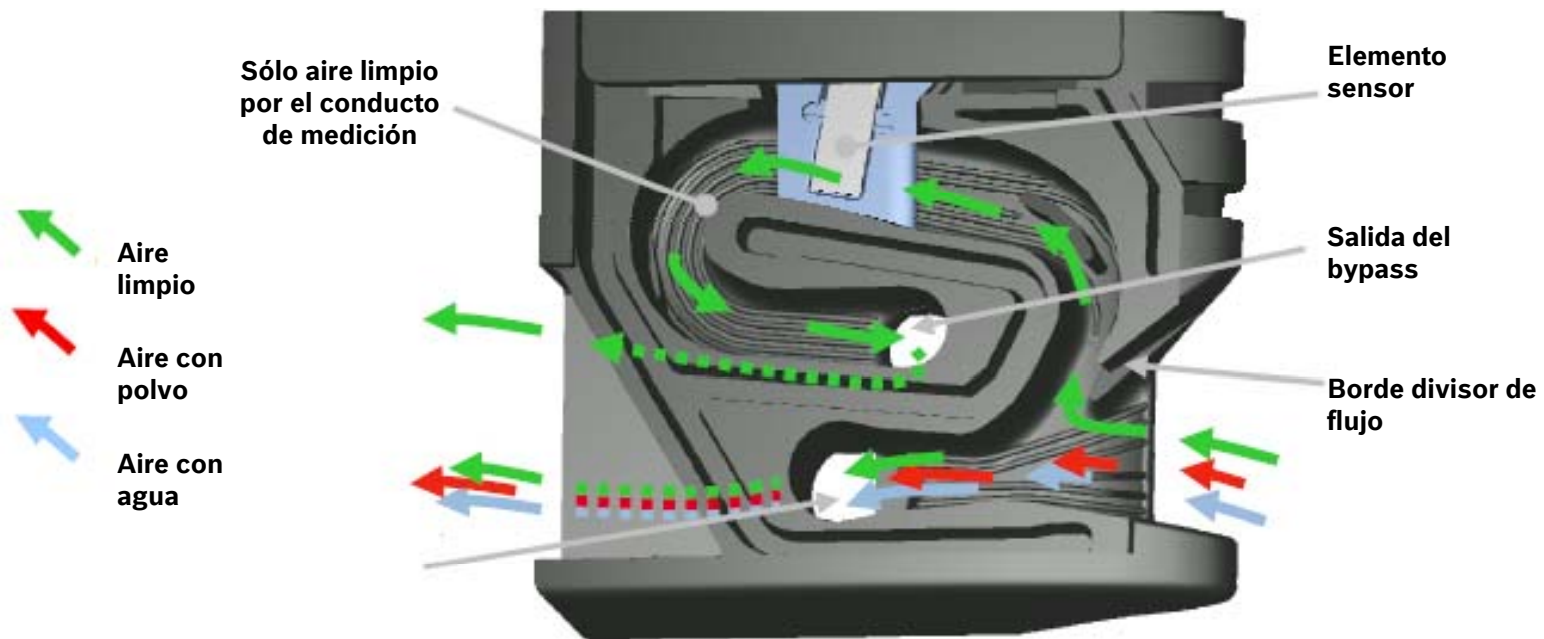

HFM7

Contaminación por aceite-efecto en la curva característica

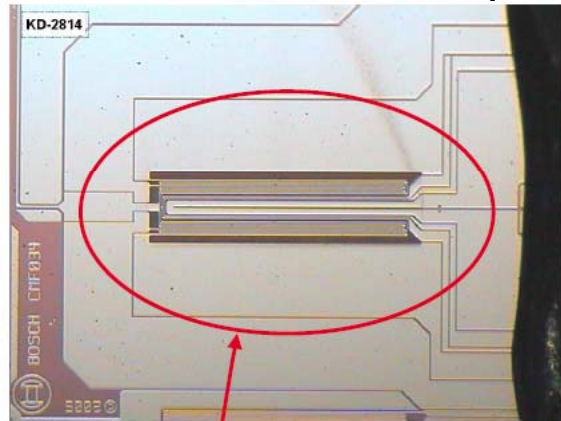

No Oil on Sensor-Chip

Deviation according to TCI

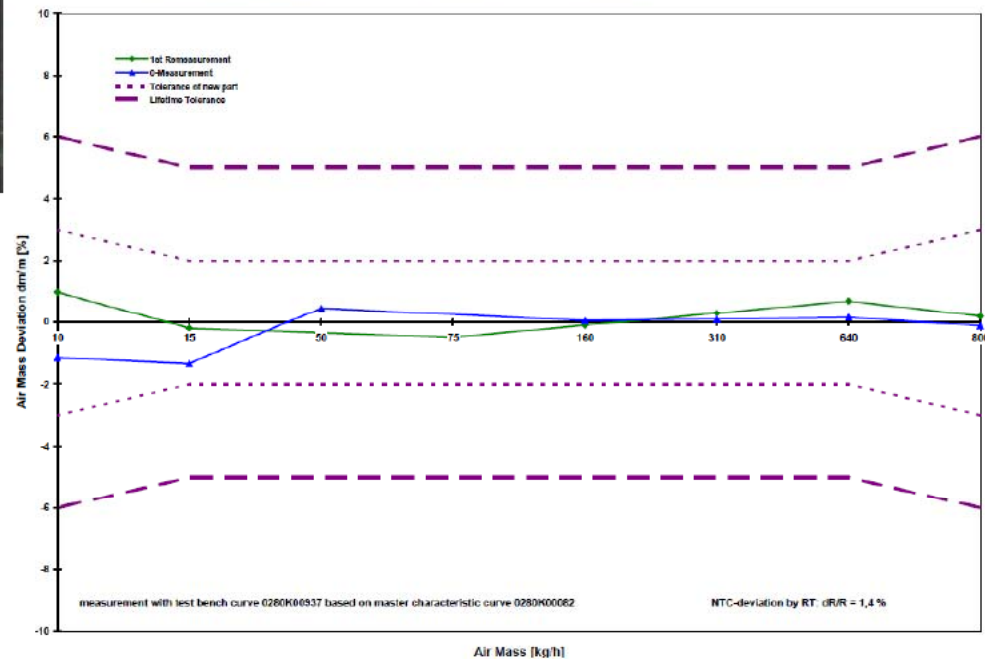

Sin aceite desviación dentro de la especificación técnica

HFM7

Contaminación por aceite-efecto en la curva característica

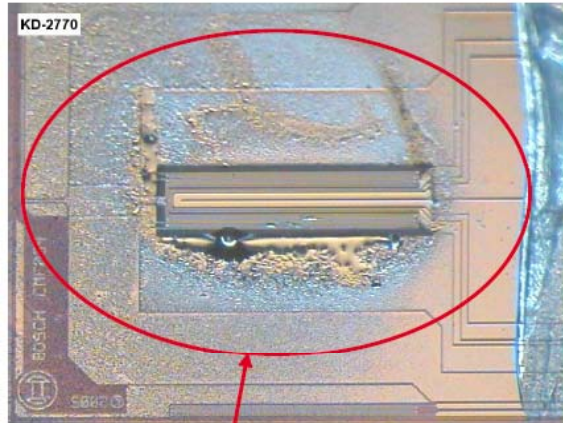

Oil on Sensor-Chip

Deviation >> 5%

Measurement with Characteristic Curve of KD-2770

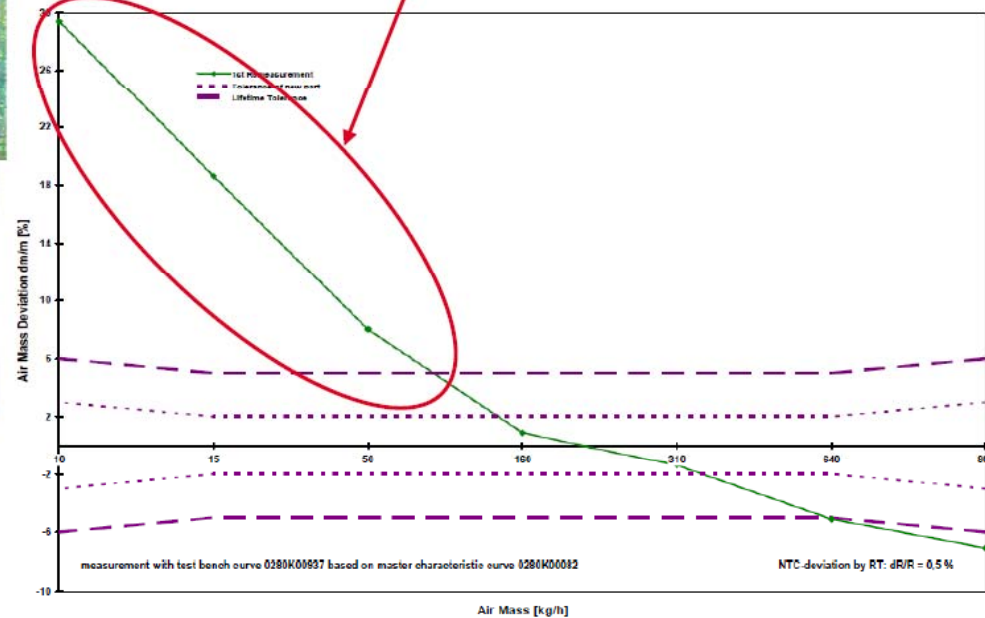

Con aceite desviación fuera de la especificación técnica >5%