



 *Open-Sankoré*

De onde podo descargalo?



Si. Podes descargalo da páxina web:

<http://open-sankore.org/en/download>

PASO 1. Cargar o Driver de multiclass

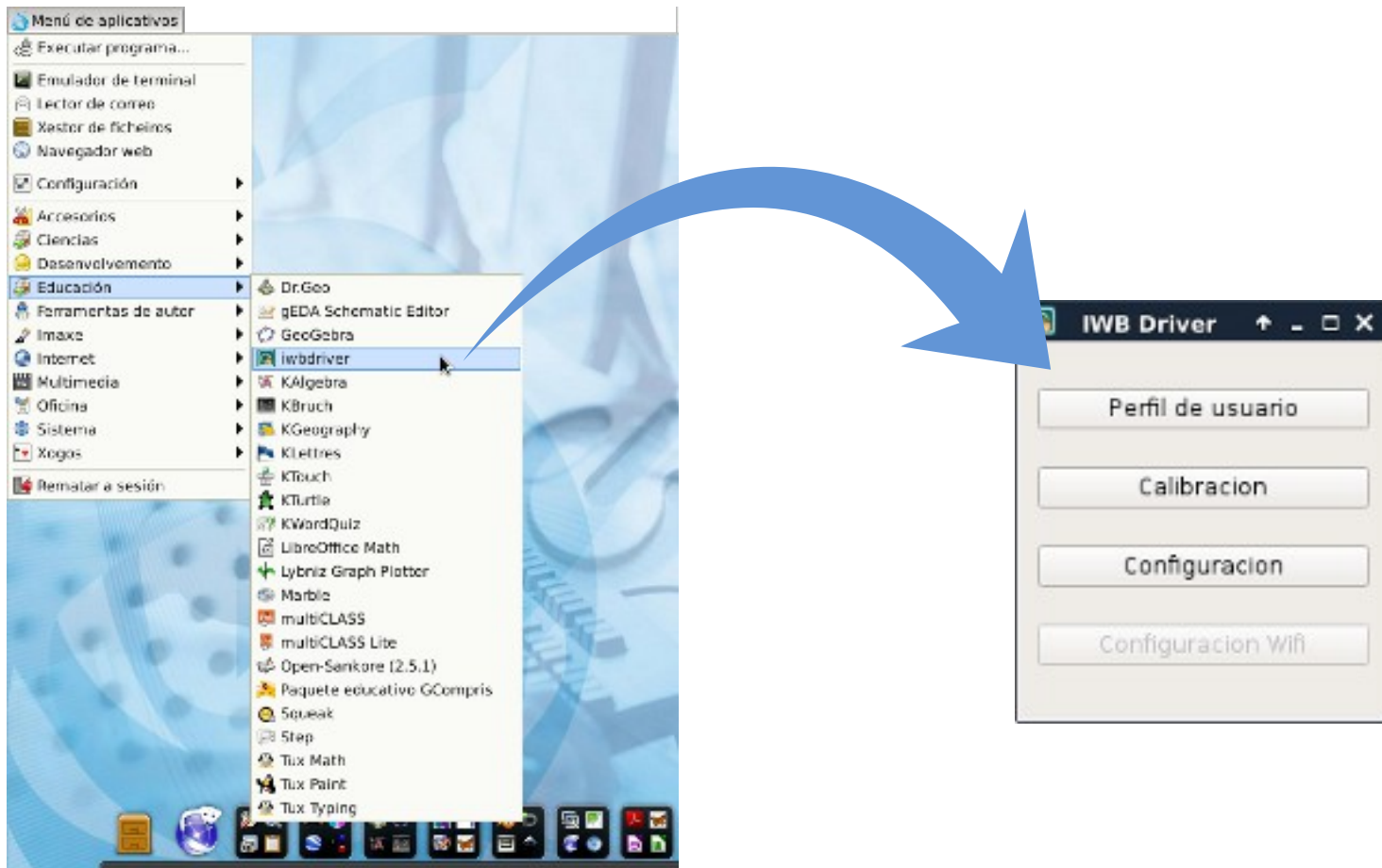

PASO 2. Calibrar (se é necesario)



Por favor, presione en el centro de cada punto rojo para calibrar la pizarra con la mayor precisión posible. Presione ESC si desea salir

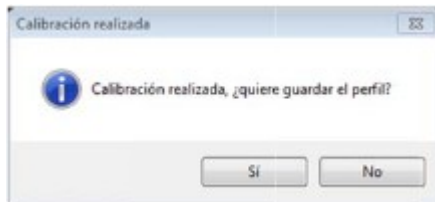

PASO 3. Abrir o programa

Todos os aplicativos -> Educación -> Open-Sankoré

O programa permite configurar o modo en como se abre:

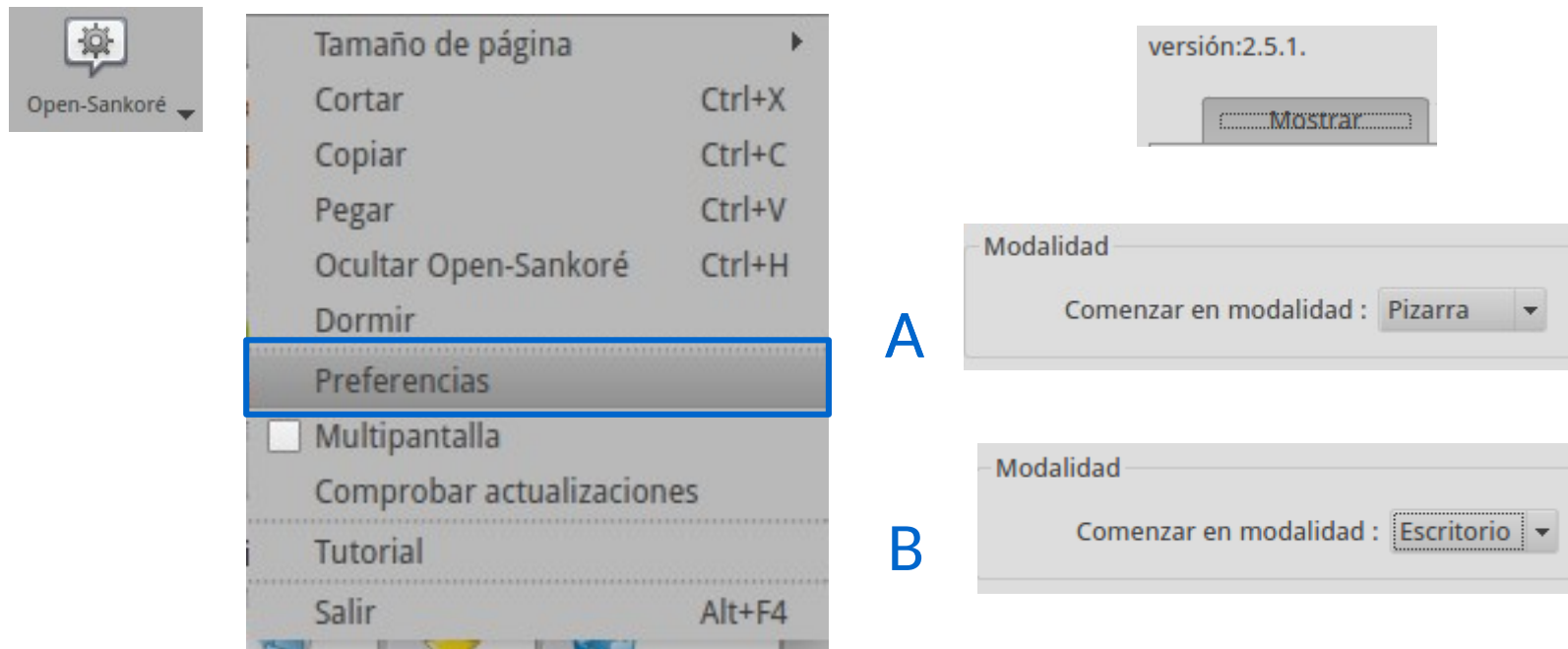

The image shows the Open-Sankoré application interface. On the left, the application icon (a gear) is labeled 'Open-Sankoré'. A context menu is open, listing various actions: 'Tamaño de página', 'Cortar (Ctrl+X)', 'Copiar (Ctrl+C)', 'Pegar (Ctrl+V)', 'Ocultar Open-Sankoré (Ctrl+H)', 'Dormir', 'Preferencias' (highlighted with a blue box), 'Multipantalla' (with an unchecked checkbox), 'Comprobar actualizaciones', 'Tutorial', and 'Salir (Alt+F4)'. To the right, two panels labeled 'A' and 'B' show the 'Modalidad' settings. Panel A shows 'Comenzar en modalidad : Pizarra' selected in a dropdown menu. Panel B shows 'Comenzar en modalidad : Escritorio' selected in a dropdown menu. Above panel A, there is a version indicator 'versión:2.5.1.' and a 'Mostrar' button.

Modalidade encerado

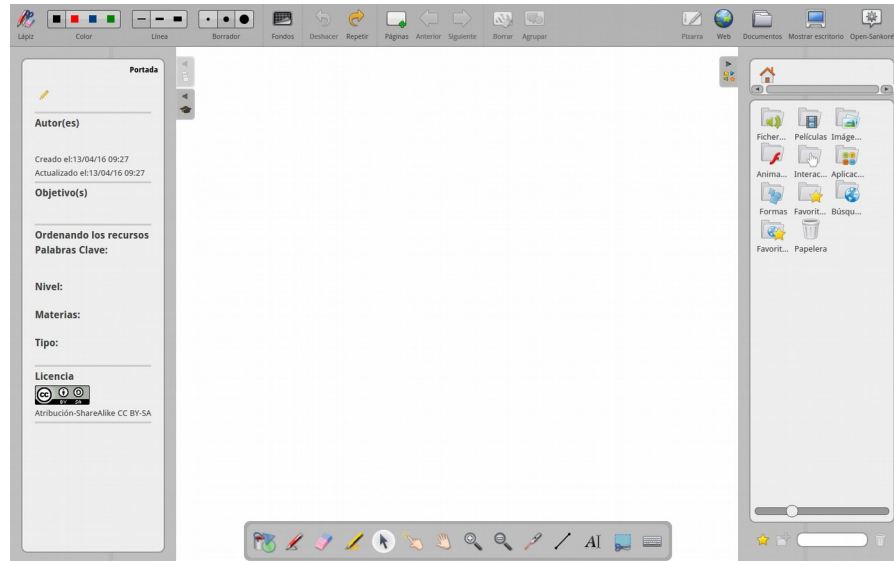

Modalidade escritorio

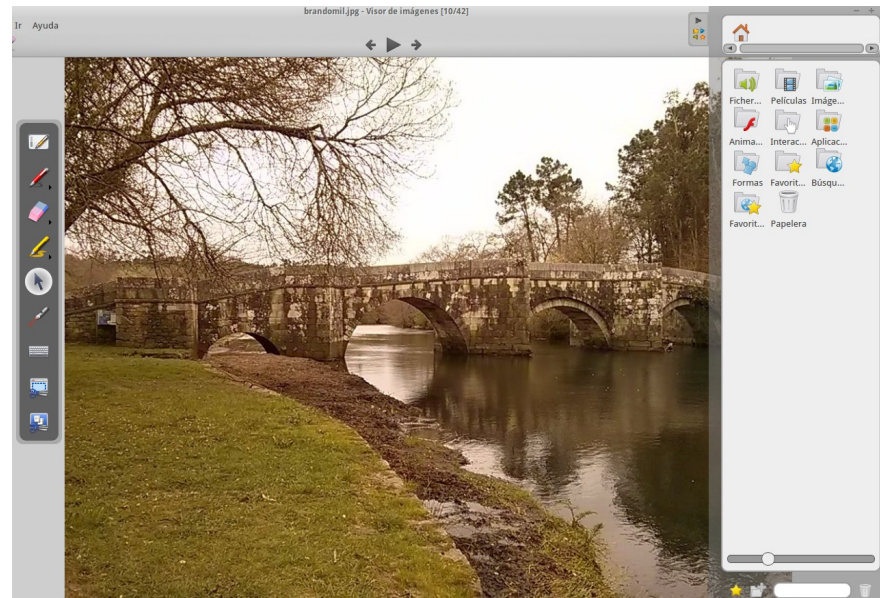

Como se pasa dun modo ao outro?

Se estamos en modo encerado

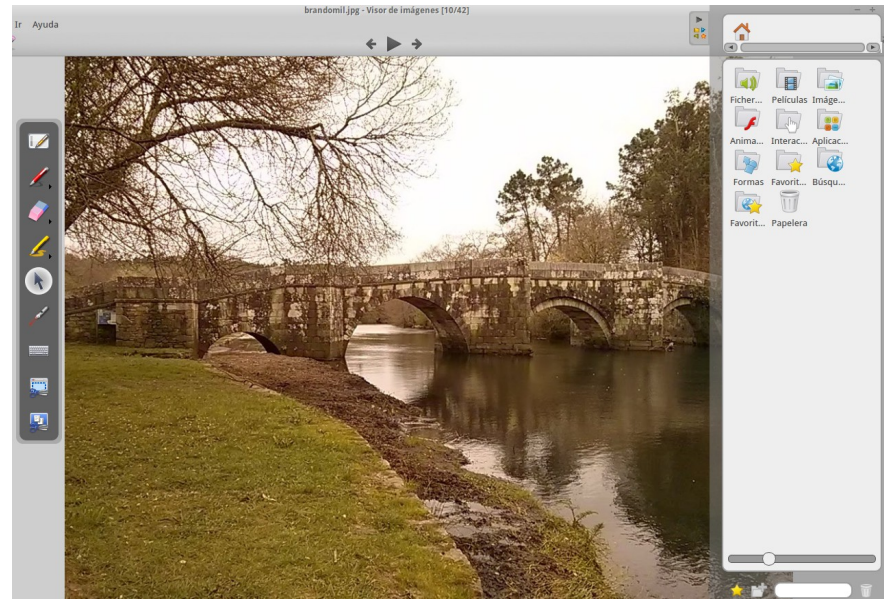
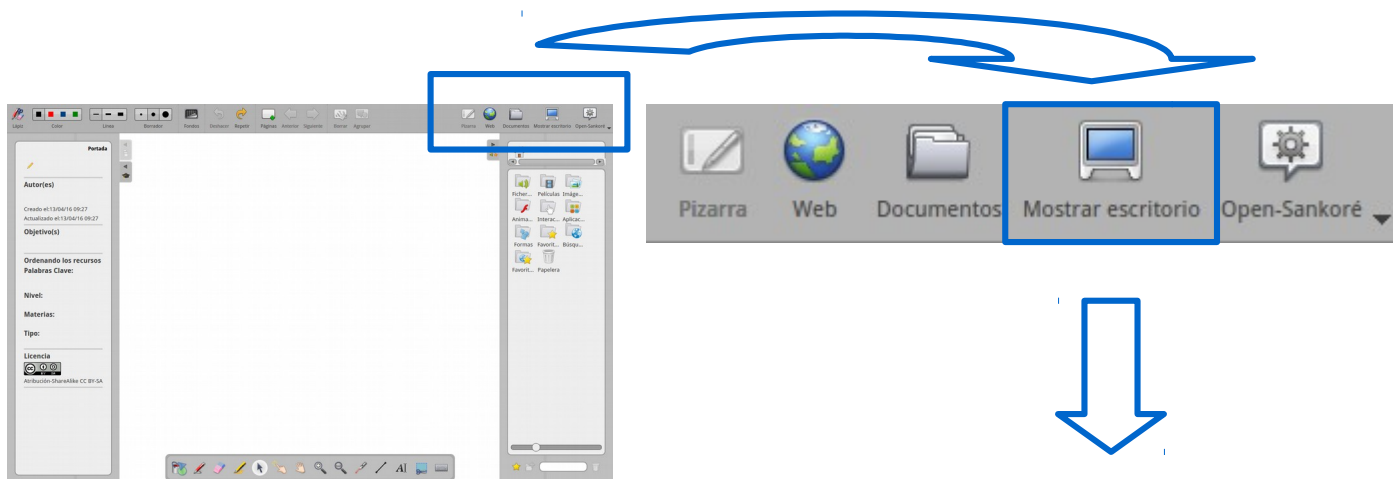

Como se pasa dun modo ao outro?

Se estamos en modo escritorio

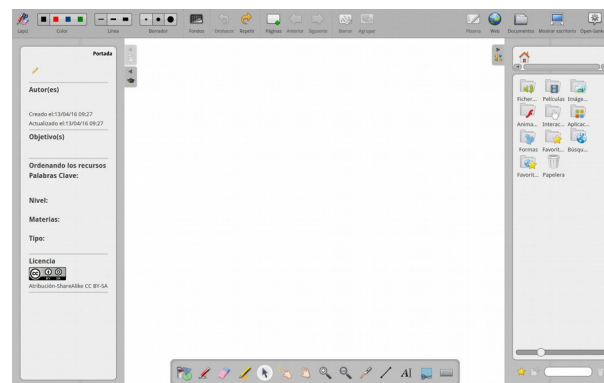
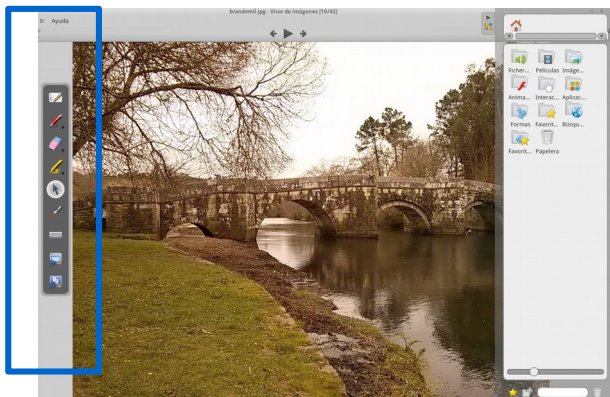

E como se minimiza?

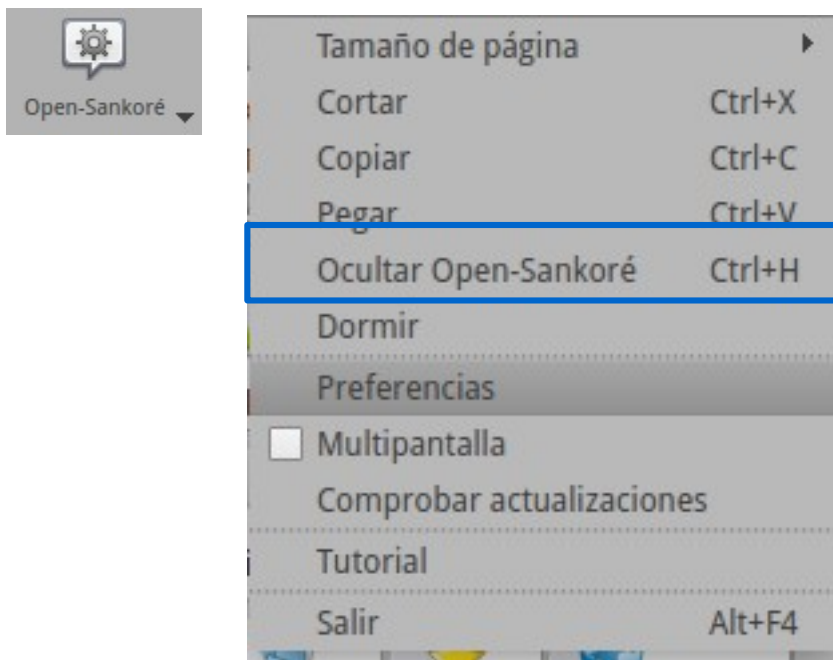

E podemos bloquear a pantalla

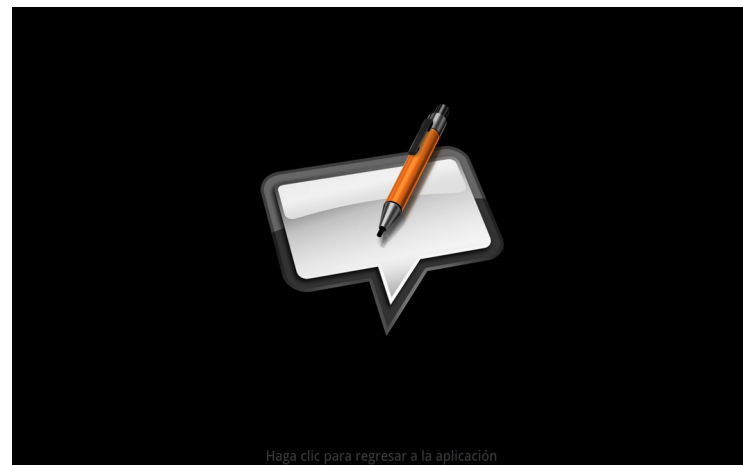
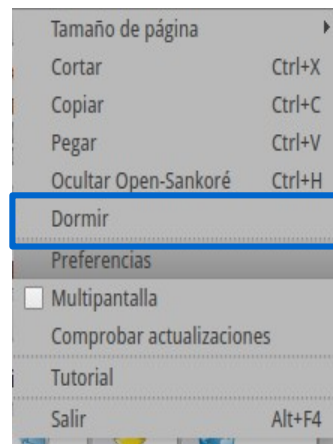



Un programa que non ten botón de abrir nin de gardar!!

Cando comezamos a traballar con el, o software vai gardando os traballos de maneira automática, coa data e a hora en Documentos

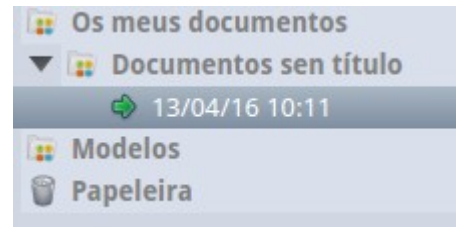

O OpenSakoré emprega por defecto Os meus documentos da aplicación. Se queremos abrir ou gardar nunha ruta do pc debemos empregar os botóns Importar ou Exportar

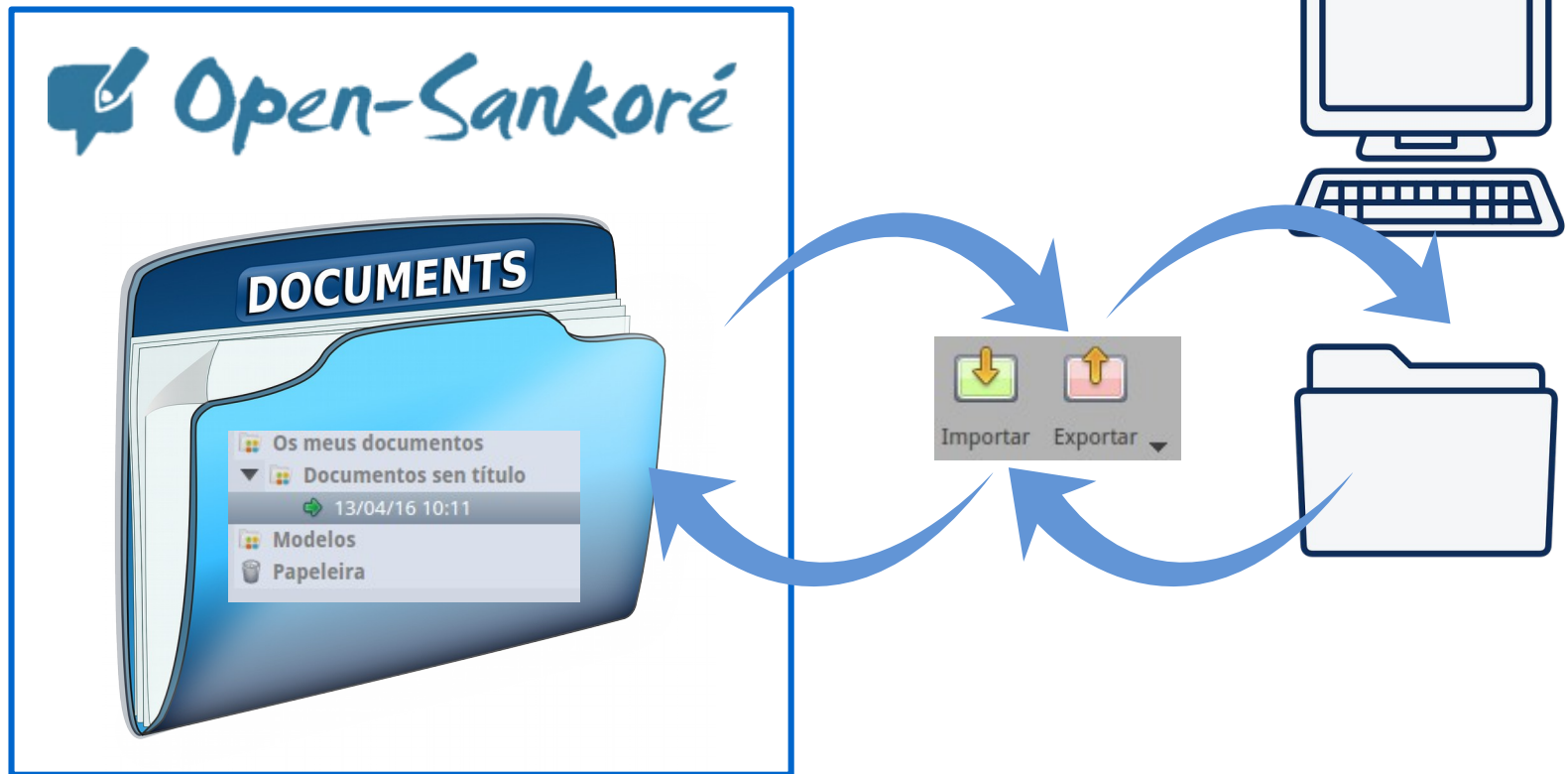

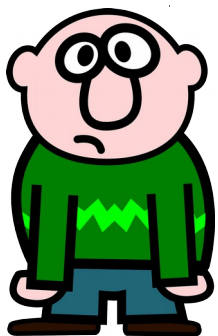

Pero eu quero darlle un nome coñecido, e gardalo nunha carpeta



1. Creamos a carpeta

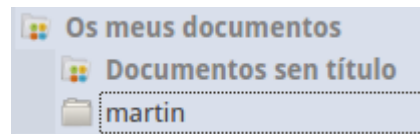
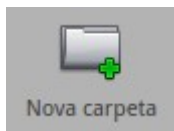

2. Seleccionamos a carpeta e clic en novo documento

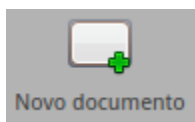

3. Cambiámoslle o nome, con dobre clic na data.

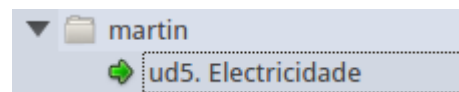

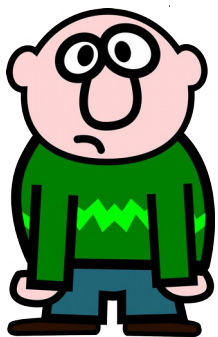

E como o mando a unha unidade usb?

1. Seleccionamos o documento e clic en Exportar

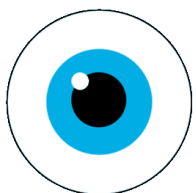
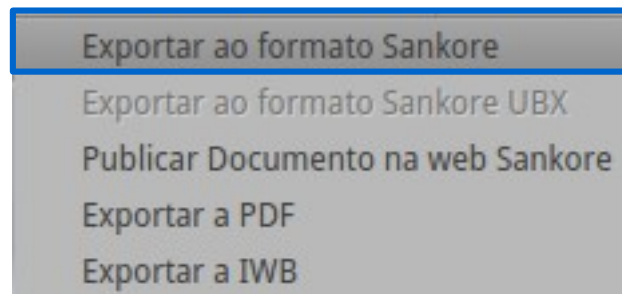
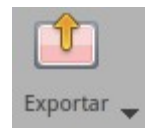
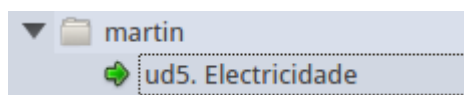

2. Procurámola unidade

As unidades usb móntanse en /media/usuario

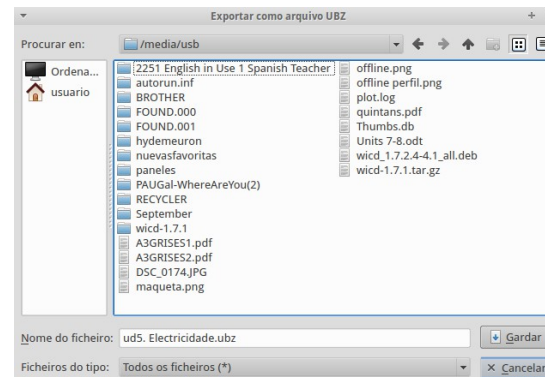

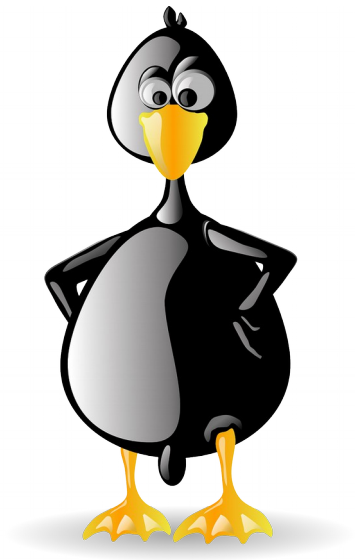

Comezamos!

O primeiro é completar os datos da portada (non é obrigatorio). Moi útil no caso de que o queiramos compartir

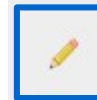

Corrente
continua

Autor(es)

Martín Pardiñas

Creado o: 13/04/16 10:23

Actualizado o: 13/04/16 10:23

Objetivo(s)

Estudo la Lei de Ohm.
Circuitos serie, para lelo e
mixto

Ordenando os recursos

Palabras Clave:

DC, corrente

Nivel:

Materias:

Tipo:

Licenza



Atribución-ShareAlike CC BY-SA

O título pasa a formar parte da primeira páxina



Imaxes

1. Engadimos imaxes propias

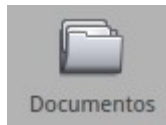

Escollemos a diapositiva

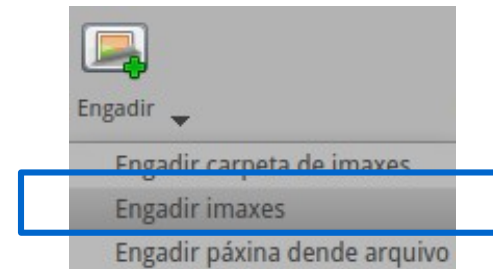
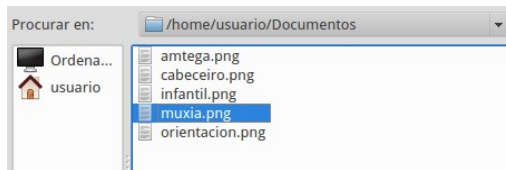

Descarga <http://atio.es/aulasdixitais/imaxes/casaman.jpg> e engádea á presentación

2. Imaxes da biblioteca



E pódese personalizar a biblioteca?



Creamos unha carpeta coas imaxes na ruta:

`/usr/local/Open-Sankore-2.5.1/library/pictures/`

Para iso abrimos o thunar con permisos de root

1. Terminal.

`su -`

(engadimos o contrasinal de root)

2. Chamamos a thunar

`thunar`

3. Vamos á ruta, e creamos a carpeta e copiamos nela as imaxes

4. Pechamos e abrimos o OpenSankoré

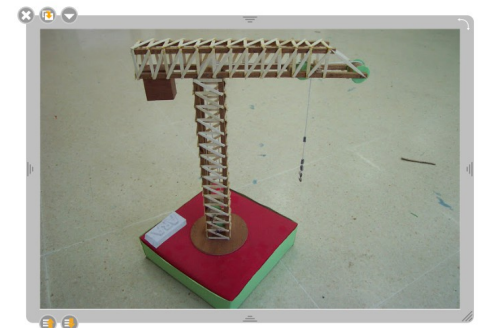
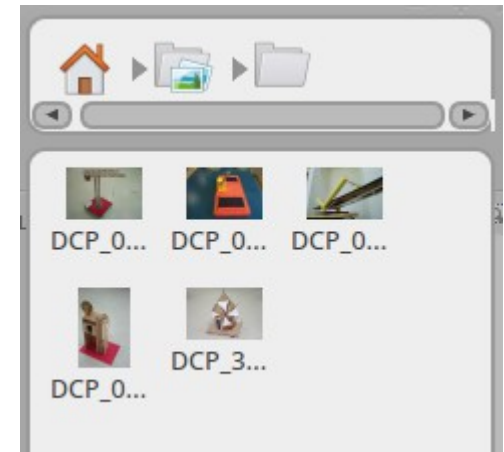

3. Procurámolas en Internet co buscador



Escribimos o enderezo de google, e vamos ao apartado de imaxes



3.2. Debian installation



Capturamos a imaxe do logotipo



Flash

Unha maneira é copiar o ficheiro swf na biblioteca (/usr/local/Open-Sankore-2.5.1/library/animations/).

Aínda que é máis cómodo e sinxelo arrastralo ficheiro desde o explorador de ficheiros á biblioteca.

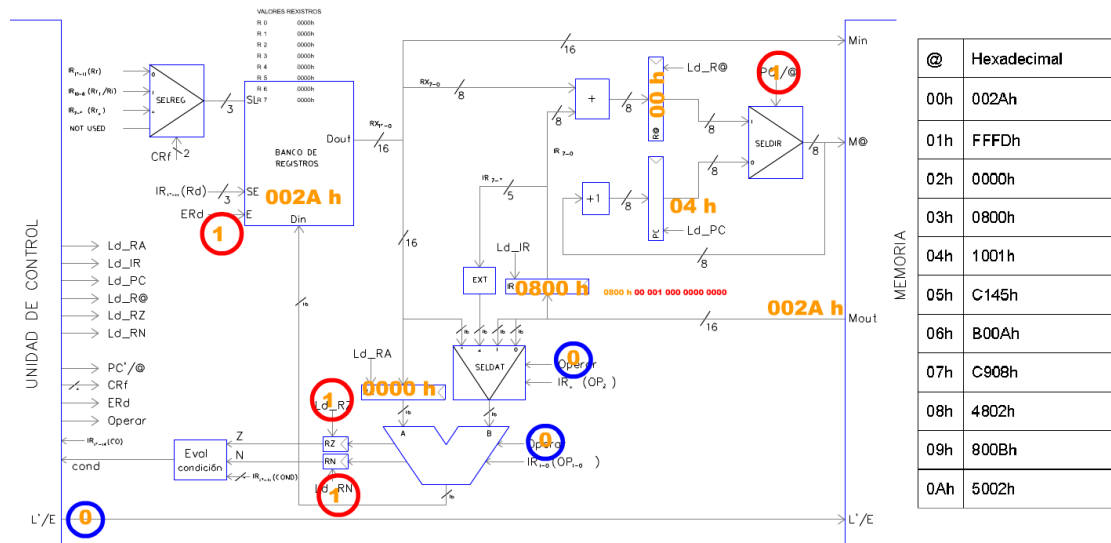

Descarga <http://atio.es/aulasdixitais/imaxes/deco.swf> e engádea á presentación

Ligazóns a páxinas web

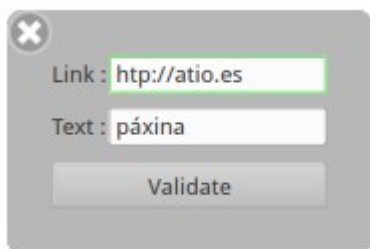

Para ir á páxina web, empregamos a icona do dedo índice



página

Tamén se pode crear unha ligazón nunha imaxe ou un debuxo

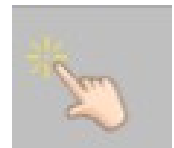
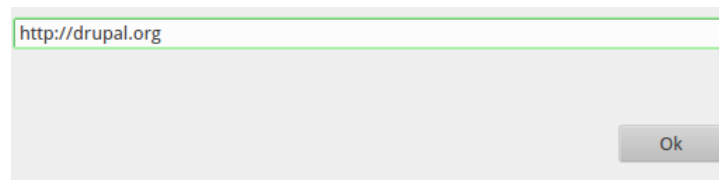
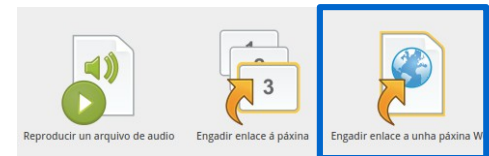
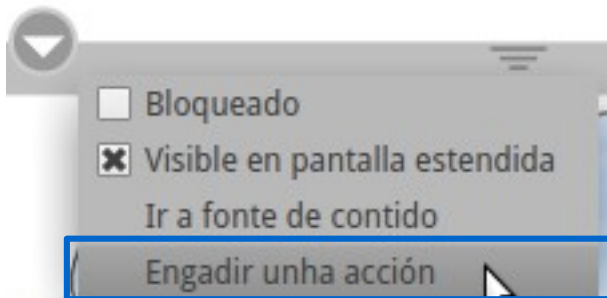
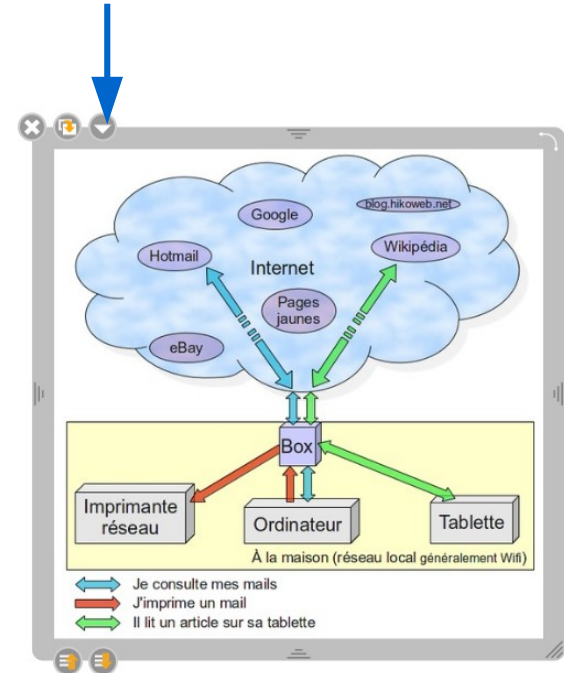
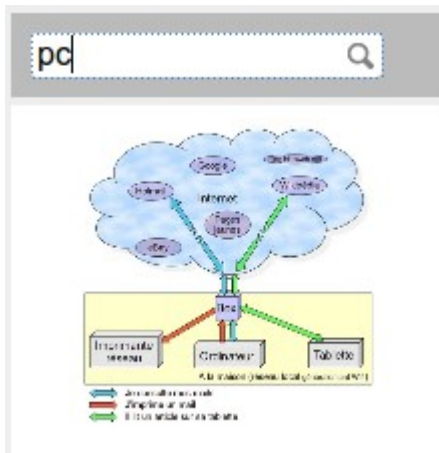
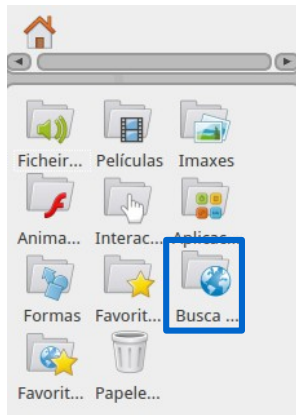

Audio, vídeo, pdf, etc

Open-Sankoré como contenedor de recursos

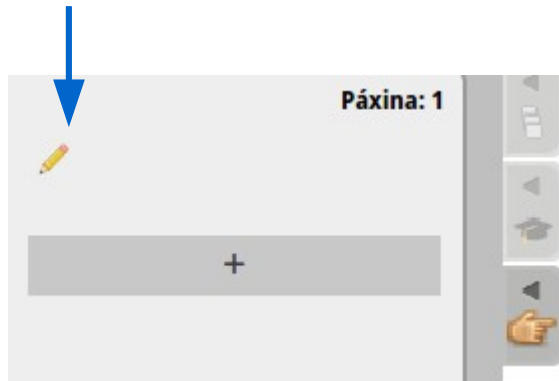

E son abertos polo sistema operativo

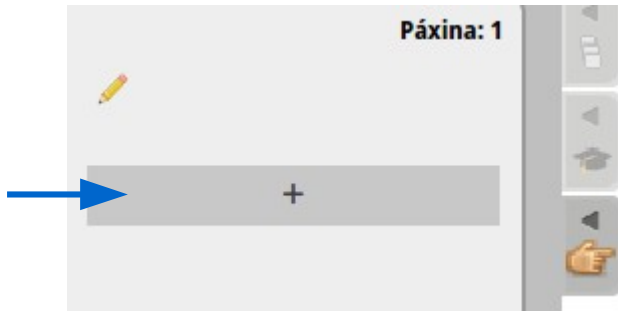

Engade o seguinte ficheiro de vídeo: <http://atlo.es/aulasdixitais/imaxes/video.mp4>

Cambiala cor do fondo de pantalla



Meter unha imaxe de fondo de pantalla

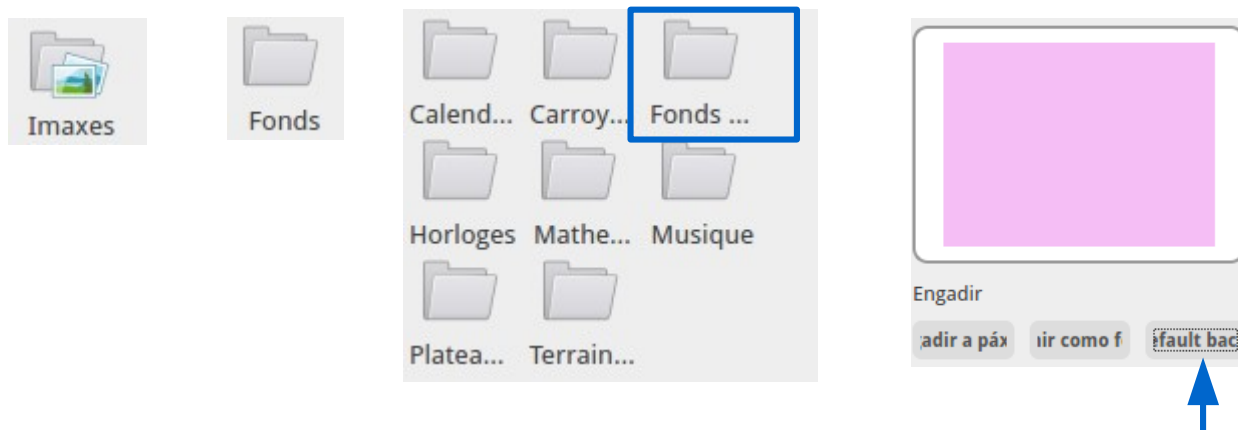

Traballar sobre unha imaxe de fondo bloqueada

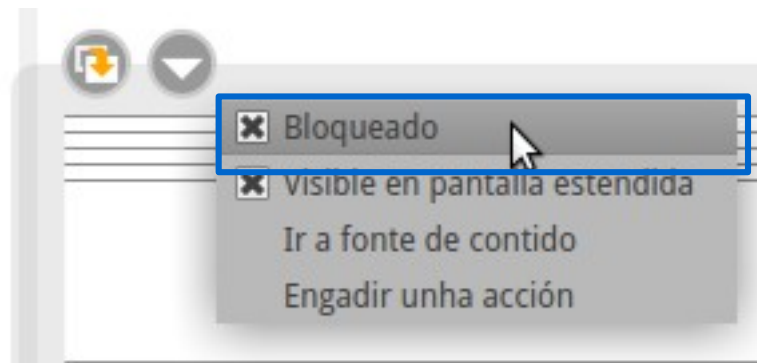
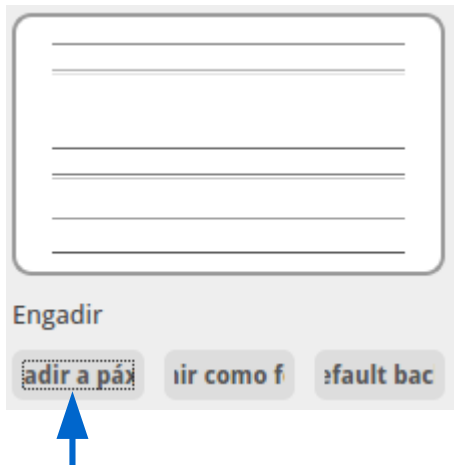
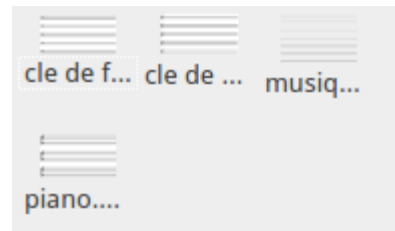
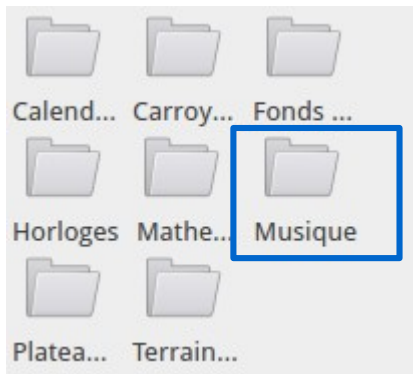
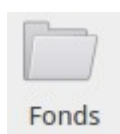
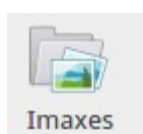

Páxina como plantilla

1. Creamos unha páxina que sirva de modelo. Por exemplo engadindo un logotipo



2. No xestor de páxinas procedemos a duplicala, tantas veces como queiramos



Captura de pantalla

1. Abrimos unha páxina web

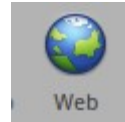

<http://espazoweb.com/dtxd/?p=559>

2. Procedemos a capturar unha imaxe

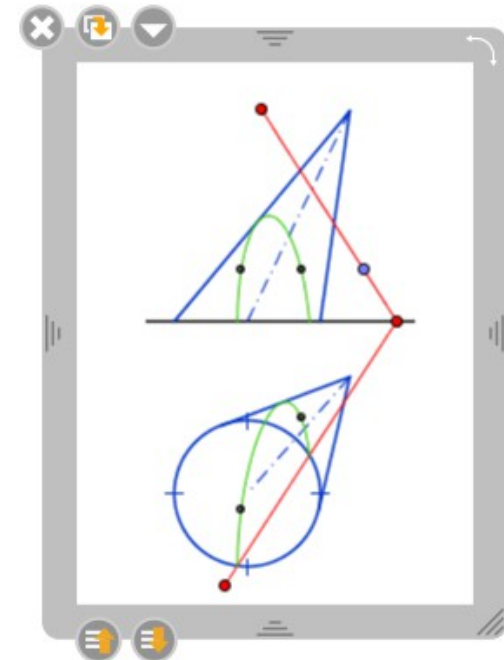

Incrustar unha páxina web

1. Abrimos unha páxina web



<http://espazoweb.com/dtxd/?p=559>

2. Procedemos a capturar unha imaxe

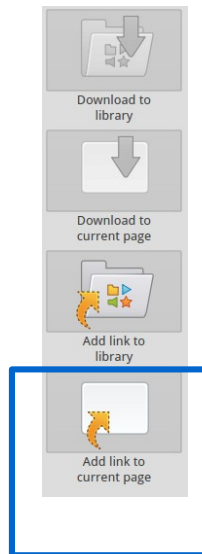

Importar e exportar en distintos formatos

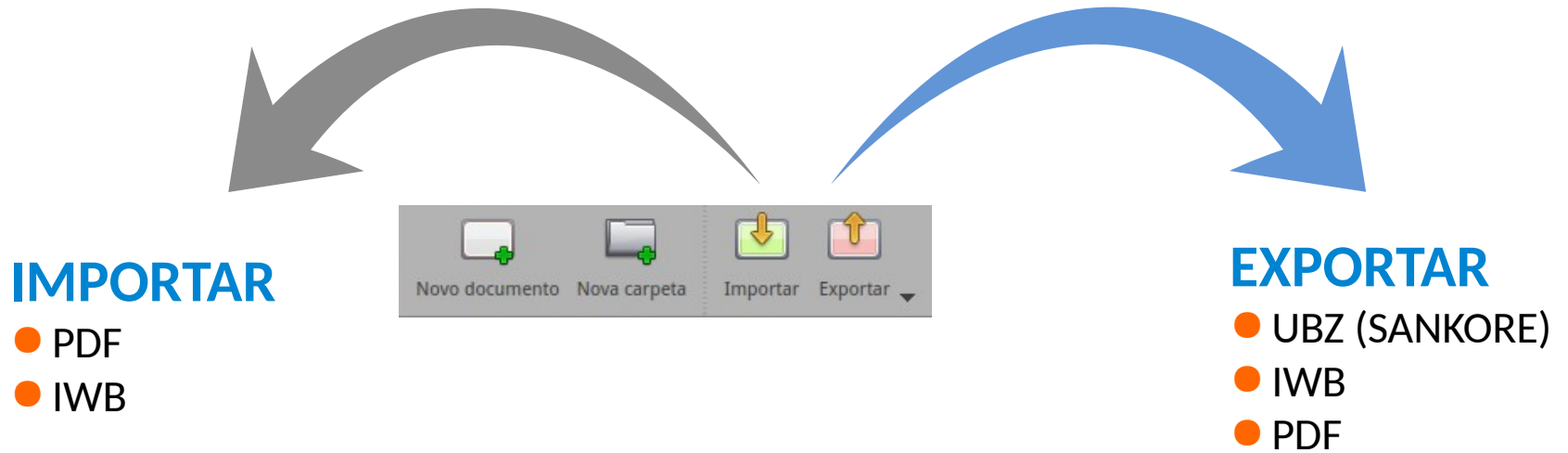

Importar unha presentación en Impress

1. Descarga a seguinte presentación Impress:

<http://atio.es/aulasdixitais/imaxes/centro.odp>

2. Exporta en formato pdf desde o Impress

3. Importa o ficheiro a Open-Sankoré

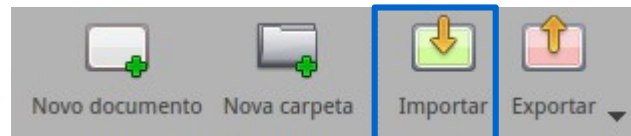



Licencia

Esta obra, elaborada por AMTEGA, está bajo una licencia Reconocimiento-CompartirIgual 3.0 España de Creative Commons.

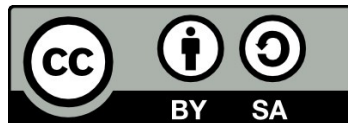

Para ver una copia de la licencia, visite:

<http://creativecommons.org/licenses/by-sa/3.0/es/>

