

# DEPORTES OLÍMPICOS

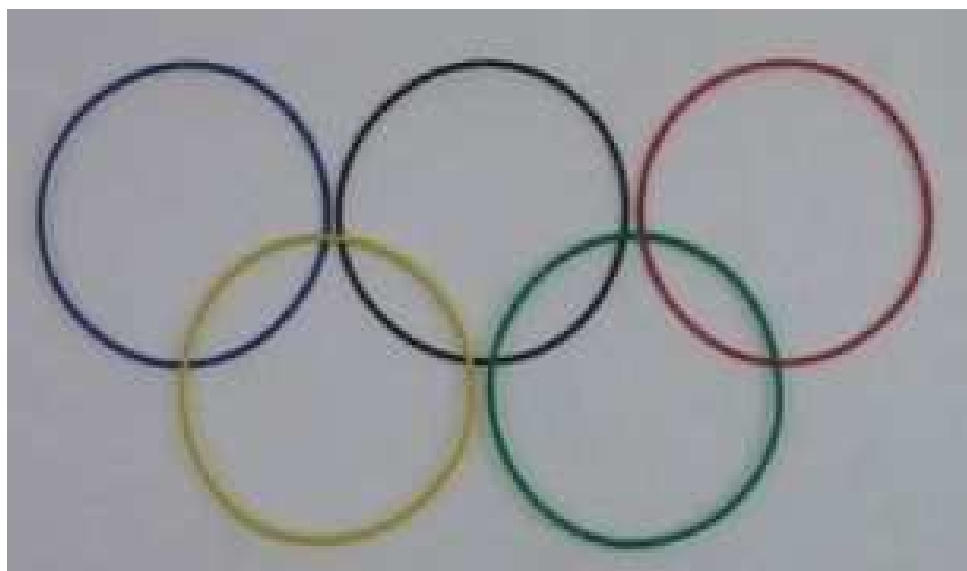

**CEIP VILAXOÁN**  
**2011/2012**

# ÍNDICE

AUTORES.....	3	NATACIÓN.....	45
ATLETISMO.....	4	PENTATLÓN MODERNO.....	48
BÁDMINTON.....	9	PIRAGÜISMO.....	50
BALONCESTO.....	12	REMO.....	53
BALONMÁN.....	15	TAEKWONDO.....	56
BOXEO.....	18	TENIS.....	59
CICLISMO.....	21	TENIS DE MESA.....	62
ESGRIMA.....	24	TIRO.....	65
FÚTBOL.....	27	TIRO CON ARCO.....	68
HALTEROFILIA.....	30	TRIATHLÓN.....	71
HÍPICA.....	33	VELA.....	74
HÓCKEY.....	36	VOLEIBOL.....	77
JUDO.....	39	XIMNASIA.....	80
LOITA.....	42	BIBLIOGRAFÍA.....	86

TRABALLO REALIZADO POLO ALUMNADO DE 6º DO CEIP VILAXOÁN NO CURSO 2011/2012 DENTRO PROXECTO DE INVESTIGACIÓN "OS XOGOS OLÍMPICOS" PROMOVIDO POLO EQUIPO DE DINAMIZACIÓN LINGÜÍSTICA E COA COLABORACIÓN DO EQUIPO TIC DO CENTRO.





# ATLETISMO

DEPORTE OLÍMPICO DENDE  
AS OLIMPIÁDAS DE ATENAS  
1898.

O ATLETISMO É UN  
DEPORTE FORMADO POR  
VARIAS DISCIPLINAS:  
CARREIRAS, SALTOS E  
LANZAMENTOS.



# AS PROBAS

AS CARREIRAS SON DE  
VELOCIDADE, FONDO, MARCHA, OBSTÁCULOS  
E RELEVOS.

OS SALTOS  
LONXITUDE, TRIPLO, PÉRTEGA E ALTURA.

OS LANZAMENTOS  
PESO, DISCO, XAVELINA E MARTELO.

# A PISTA

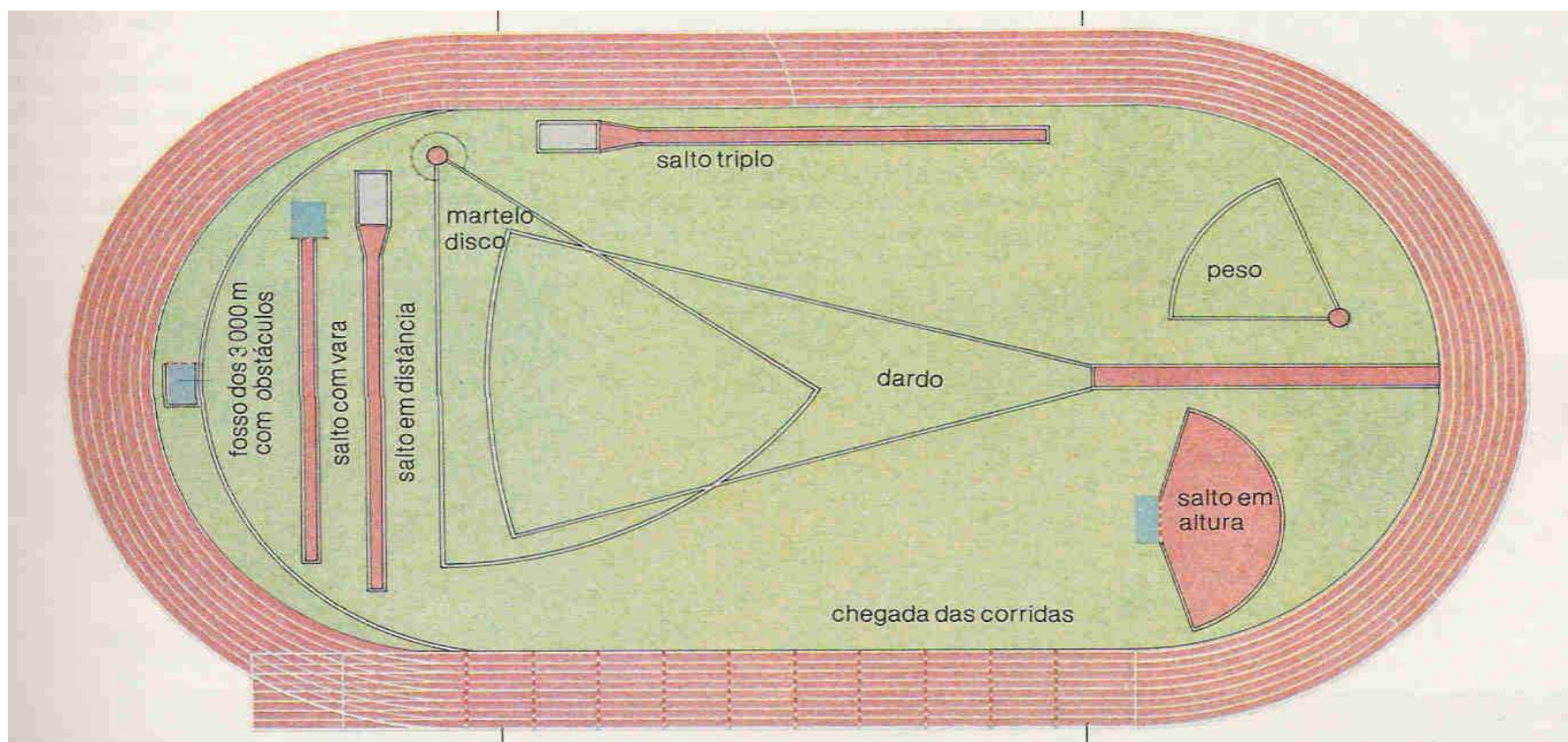

# MATERIAL PARA A SÚA PRÁCTICA



**ZAPATILLAS  
DE CRAVOS**



**PESO**



**XAVELINA**



**DISCO**



**MARTELO**



**VALADO**



**ZAPATILLAS  
DE  
LANZAMIENTO**



**TESTEMUÑA  
DE RELEVOS**



**XAULA DE  
MARTELO E  
DISCO**



**COLCHONETA DE  
SALTO CON  
PÉRTEGA**

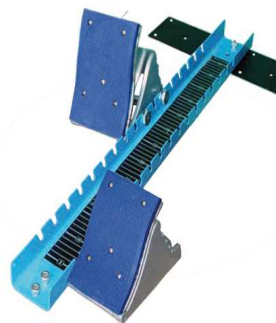

**TACOS DE SAÍDA**



**COLCHONETA DE  
SALTO DE  
ALTURA**

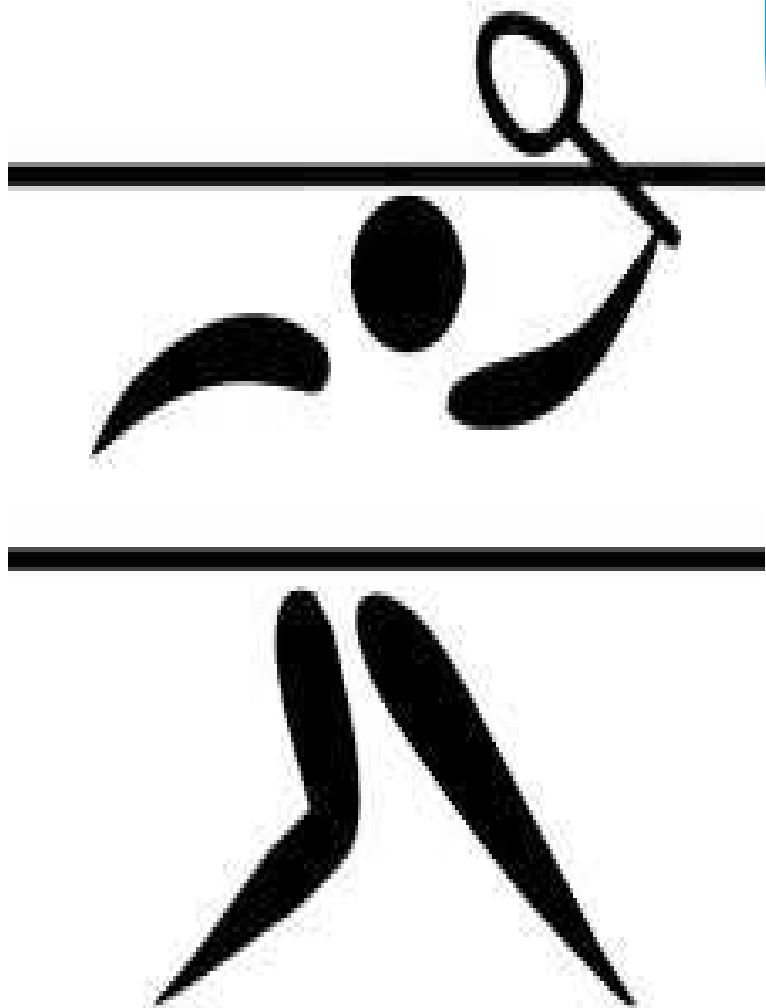

# BÁDMINTON

DEPORTE OLÍMPICO DENDE AS  
OLIMPIADAS DE BARCELONA  
DO ANO 1992.

CONSISTE EN IMPULSAR,  
CUNHA RAQUETA, O VOLANTE  
POR ENRIBA DUNHA REDE  
PARA QUE CAIA NO CAMPO  
CONTRARIO.



# A PISTA

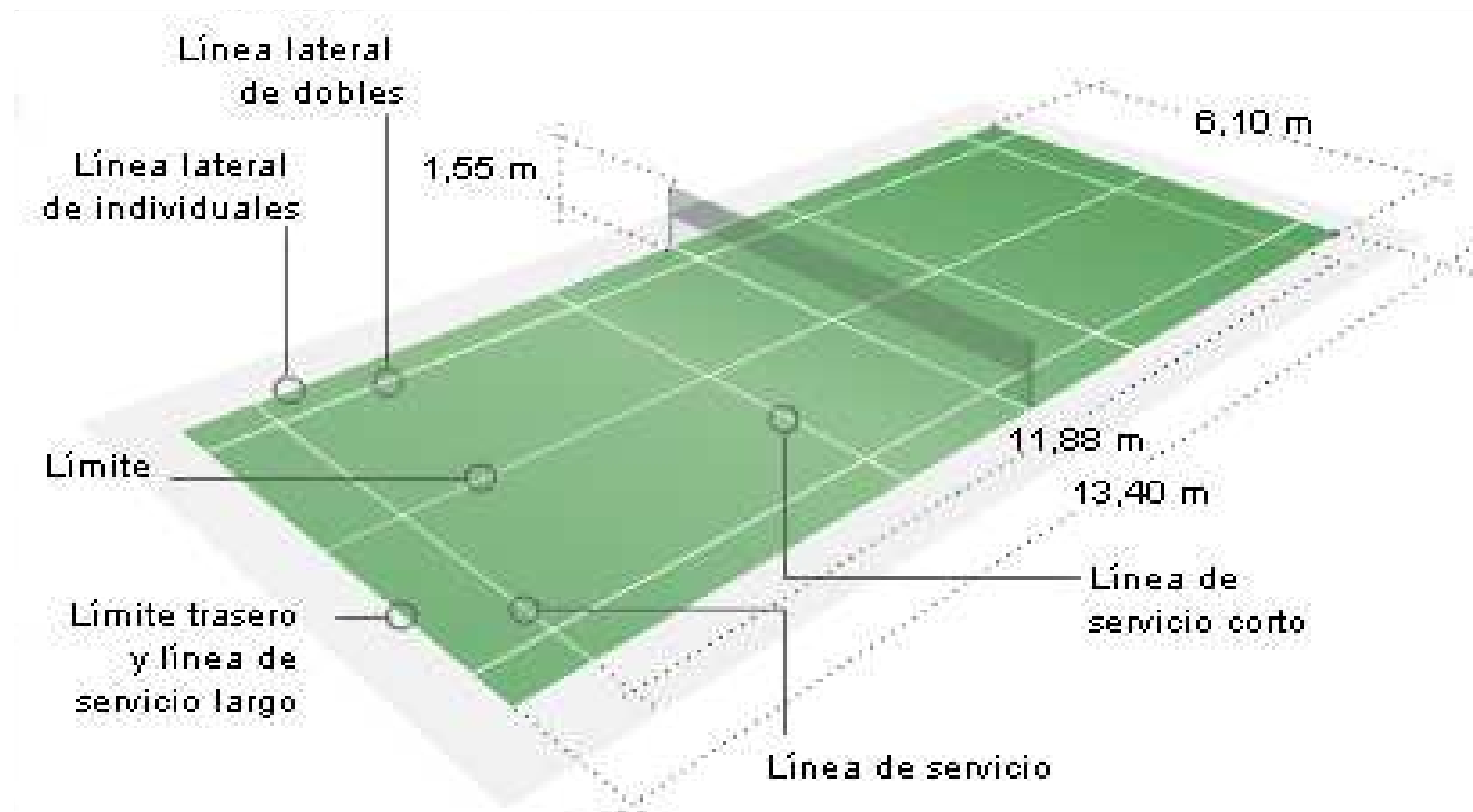

# MATERIAL PARA A SÚA PRÁCTICA



**RAQUETA**



**VESTIMENTA**



**VOLANTE**



**REDE**



# BALONCESTO

DEPORTE OLÍMPICO  
DENDE BERLÍN 1936.

O OBXECTIVO DO XOGO É  
METER O BALÓN NA  
CANASTRA DO EQUIPO  
CONTRARIO.



# A CANCHA

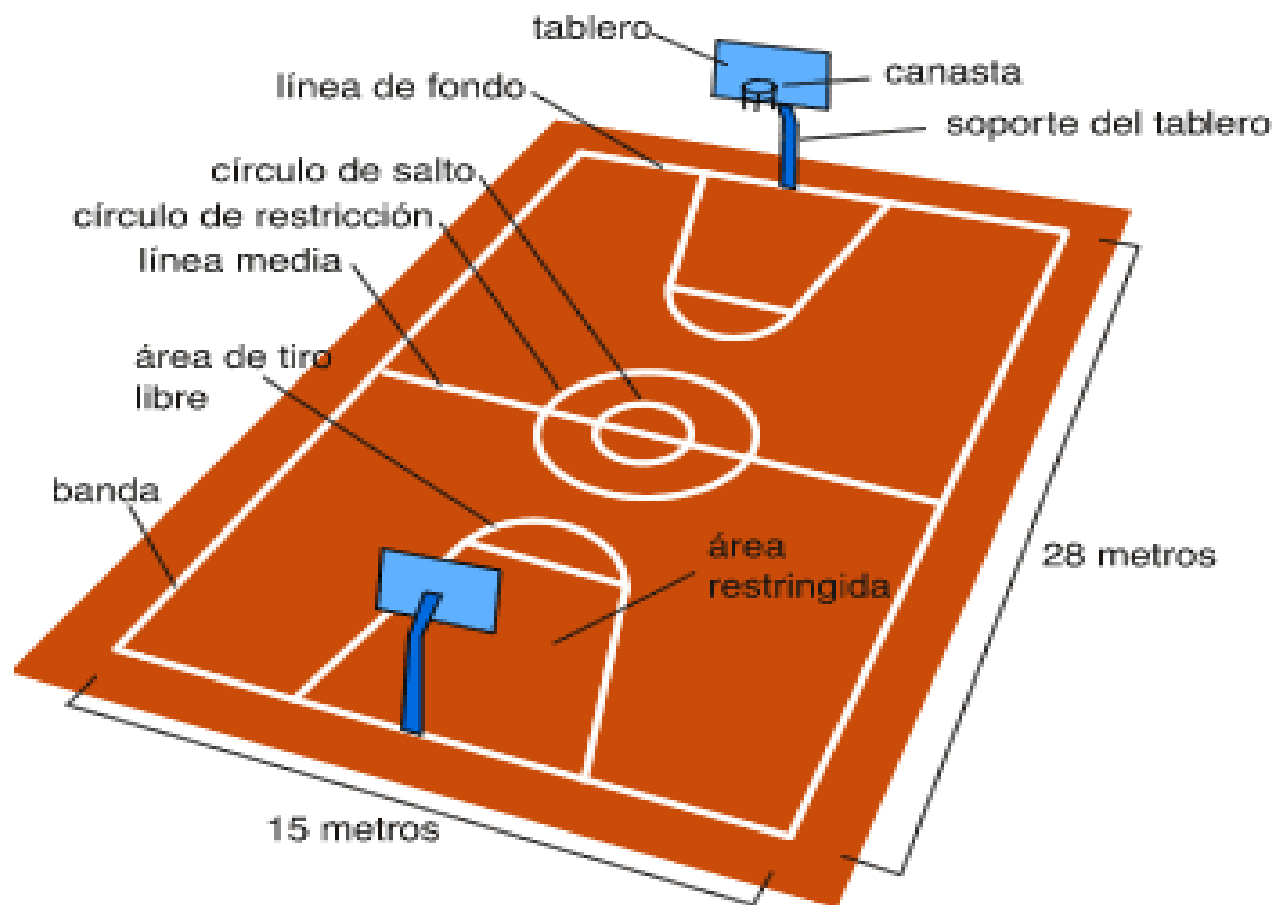

# MATERIAL PARA A SÚA PRÁCTICA



**EQUIPAXE**

**ZAPATILLAS**



**BALÓN**



**CANASTRA**



# BALONMÁN

DEPORTE OLÍMPICO  
DENDE AS OLIMPIÁDAS DE  
MÚNICH 1972.

O OBXECTIVO DO XOGO É  
DESPRAZAR (COA MAN) A  
PELOTA A TRAVÉS DO CAMPO  
PARA METELA NA PORTARÍA  
CONTRARIA.

# TERREO DE XOGO

La superficie es lisa y pulida.

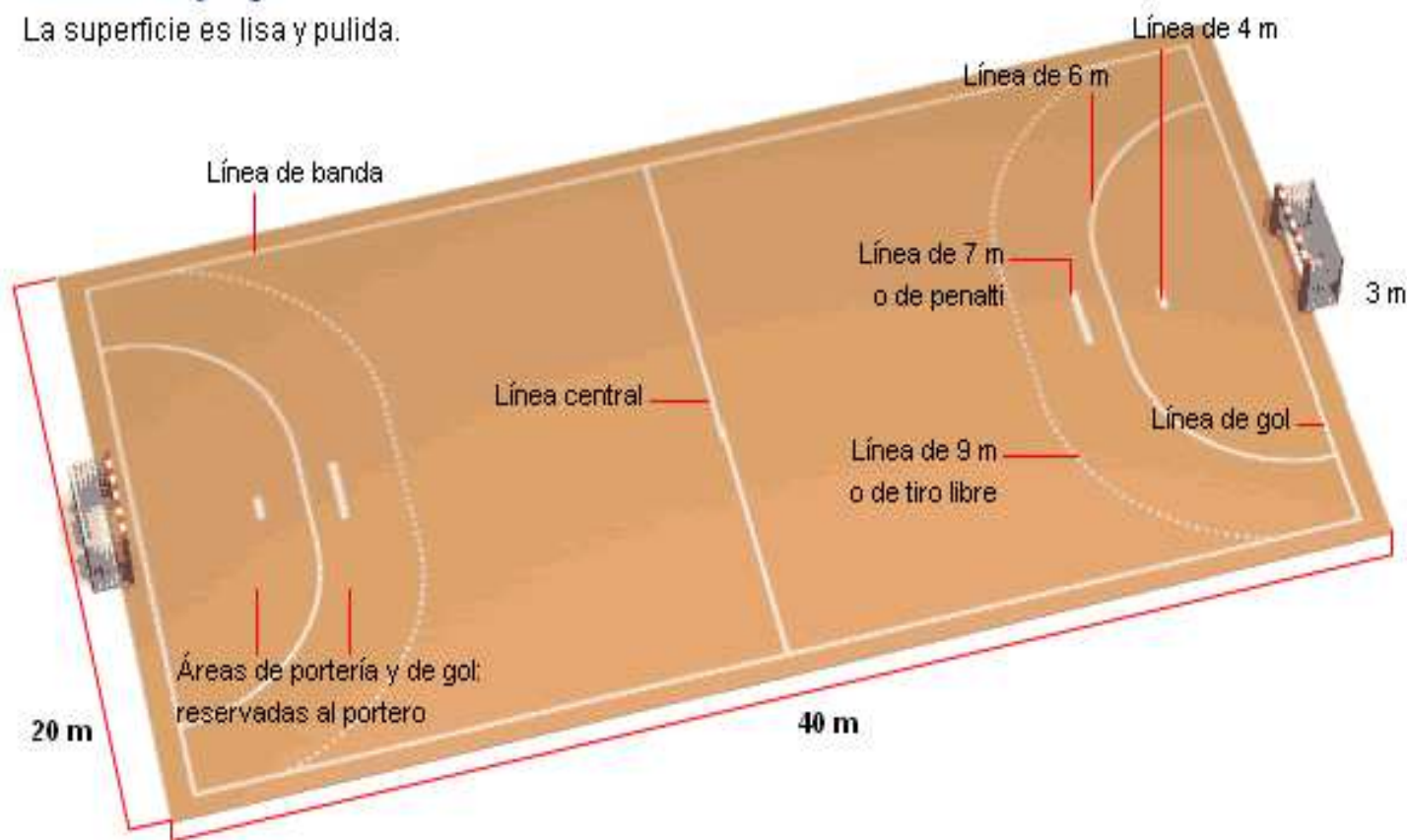

# MATERIAL PARA A SÚA PRÁCTICA



DEPORTIVAS



BALÓN



EQUIPACIÓN

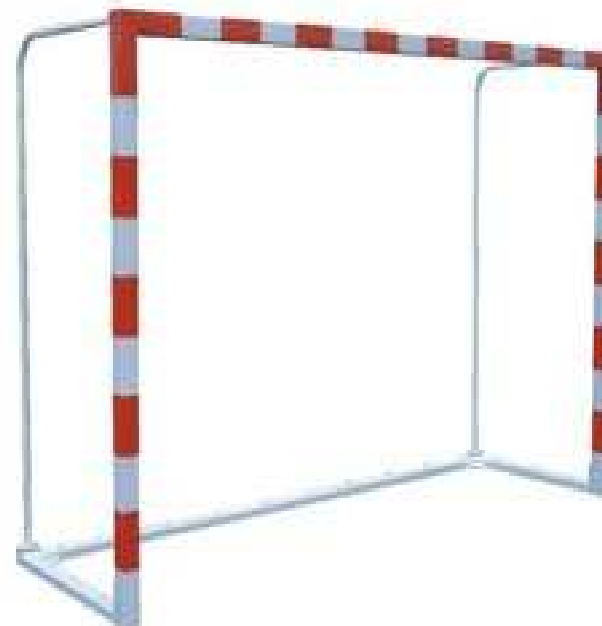

PORTARÍA



# BOXEO

DEPORTE OLÍMPICO DENDE AS OLIMPIADAS DE SAN LUÍS EN 1904.

DEPORTE DE CONTACTO NO QUE OS CONTRINCANTES LOITAN UTILIZANDO UNICAMENTE OS SEUS PUÑOS CON LUVAS, PARA GOLPEAR AO SEU ADVERSARIO.

# O R I N G



CEIP VILAXOÁN 2011/2012

# MATERIAL PARA A SÚA PRÁCTICA



LUVAS



CALZADO



MÁSCARA



CALZÓN



PROTECTOR  
BUCAL

PROTECTORES  
DE PERNAS







# CICLISMO

**DEPORTE OLÍMPICO DESDE AS  
OLIMPIADAS DE ATENAS 1896.**

**DEPORTE NO QUE SE USA UNHA  
BICICLETA PARA PERCORRER  
CIRCUÍTOS, AO AIRE LIBRE OU  
NUNHA PISTA CUBERTA.**

# VELÓDROMO



CEIP VILAXOÁN 2011/2012

# MATERIAL PARA A SÚA PRÁCTICA



**BICICLETA**



**PANTALÓN**



**CASCO**



**MAILLOT**



**CALZADO**



**LUVAS**

# ESGRIMA

DEPORTE OLÍMPICO DENDE AS  
OLIMPIADAS DE 1896 EN  
ATENAS.

DEPORTE DE COMBATE,  
ONDE SE ENFRONTAN DOUS  
CONTRINCANTES QUE DEBEN  
INTENTAR TOCARSE CUNHA  
ARMA BRANCA .



# PEDANA

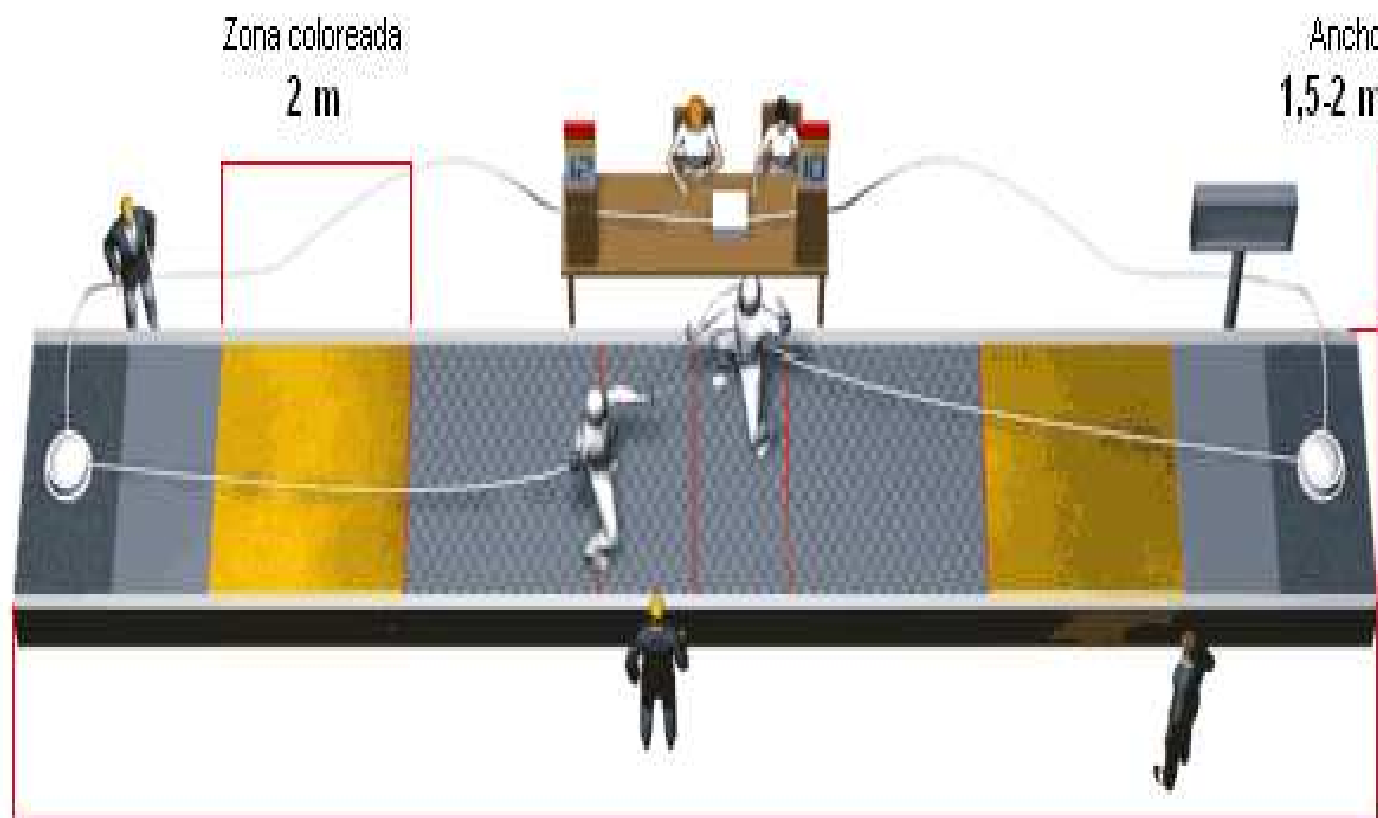

www.ceipvilaxoan.es

# MATERIAL PARA A SÚA PRÁCTICA



**SABRE**



**FLORETE**



**ESPADA**



**ZAPATILLAS  
ESGRIMA**



**TRAXE  
PROTECTOR**



# FÚTBOL



DEPORTE OLÍMPICO DENDE  
AS OLIMPIADAS DE 1900 EN  
PARÍS.

DEPORTE DE EQUIPO NO  
QUE HAI QUE METER O BALÓN  
NA PORTERÍA CONTRARIA CO  
PÉ.

# TERREO DE XOGO

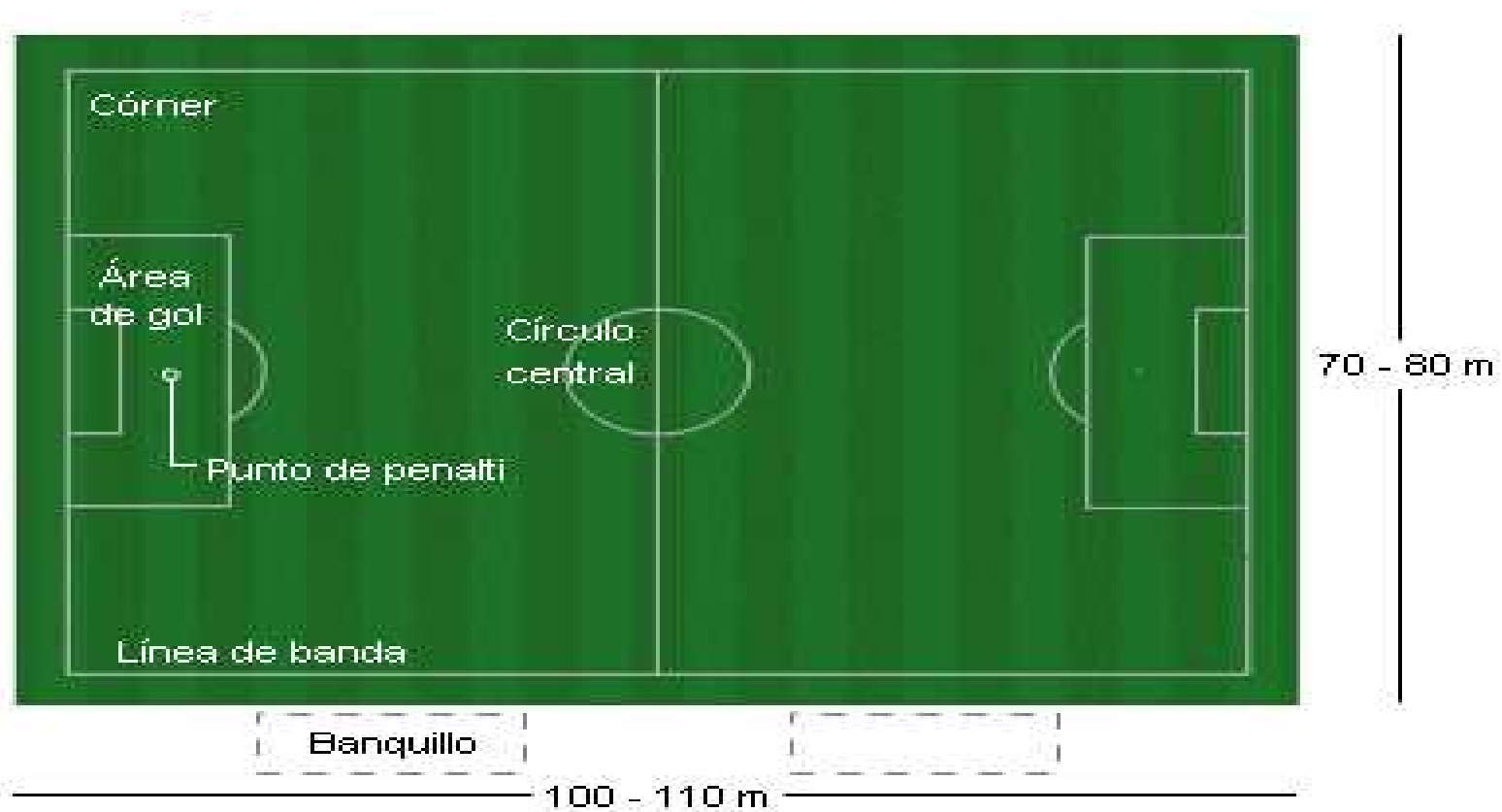



# MATERIAL PARA A SÚA PRÁCTICA

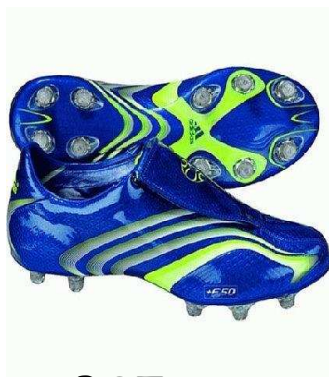

**BOTAS**



**LUVAS**



**CANELEIRAS**



**BALÓN**



**MEDIAS**



**EQUIPACIÓN**

# HALTEROFILIA

DEPORTE OLÍMPICO DENDE  
AS OLIMPIADAS DE ATENAS  
1896 E CON PRESENCIA  
OFICIAL DENDE PARÍS 1924.

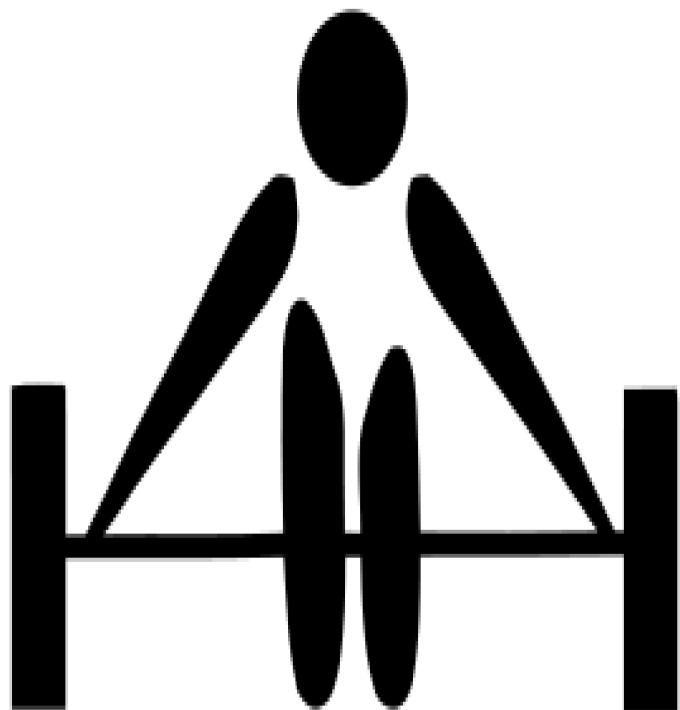

DEPORTE CONSISTENTE NO  
LEVANTAMENTO DA MAIOR  
CANTIDADE DE PESO NUNHA  
BARRA.

# PLATAFORMA



CEIP VILAXOÁN 2011/2012

# MATERIAL PARA A SÚA PRÁCTICA



**DISCOS**



**CINTO**

**VESTIMENTA**



**ZAPATILLAS**



**BARRA OLÍMPICA**

# HÍPICA

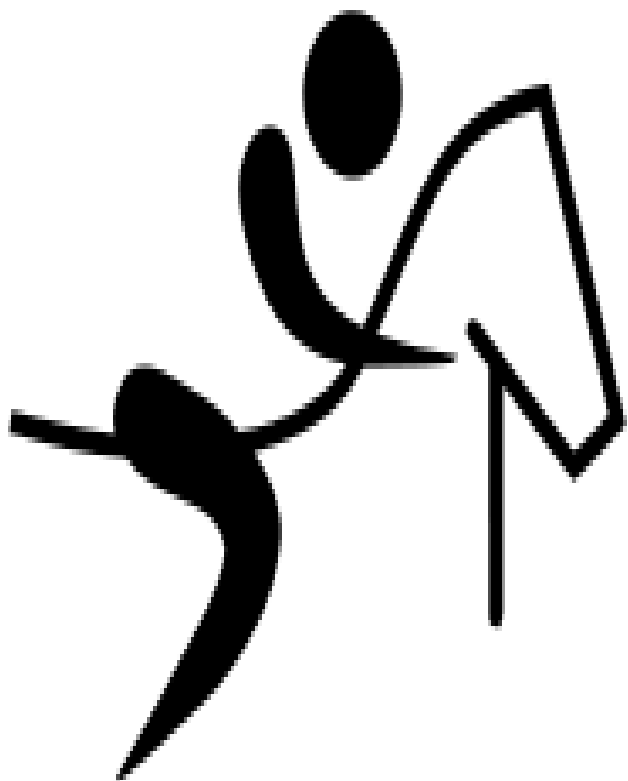

DEPORTE OLÍMPICO EN ATENAS  
1896 E SEN INTERRUPCIÓN  
DENDE ESTOCOLMO 1912.

AS COMPETICIÓNS OLÍMPICAS  
DA HÍPICA SON A DOMA E O  
SALTO DE OBSTÁCULOS.

# PISTA DE SALTOS

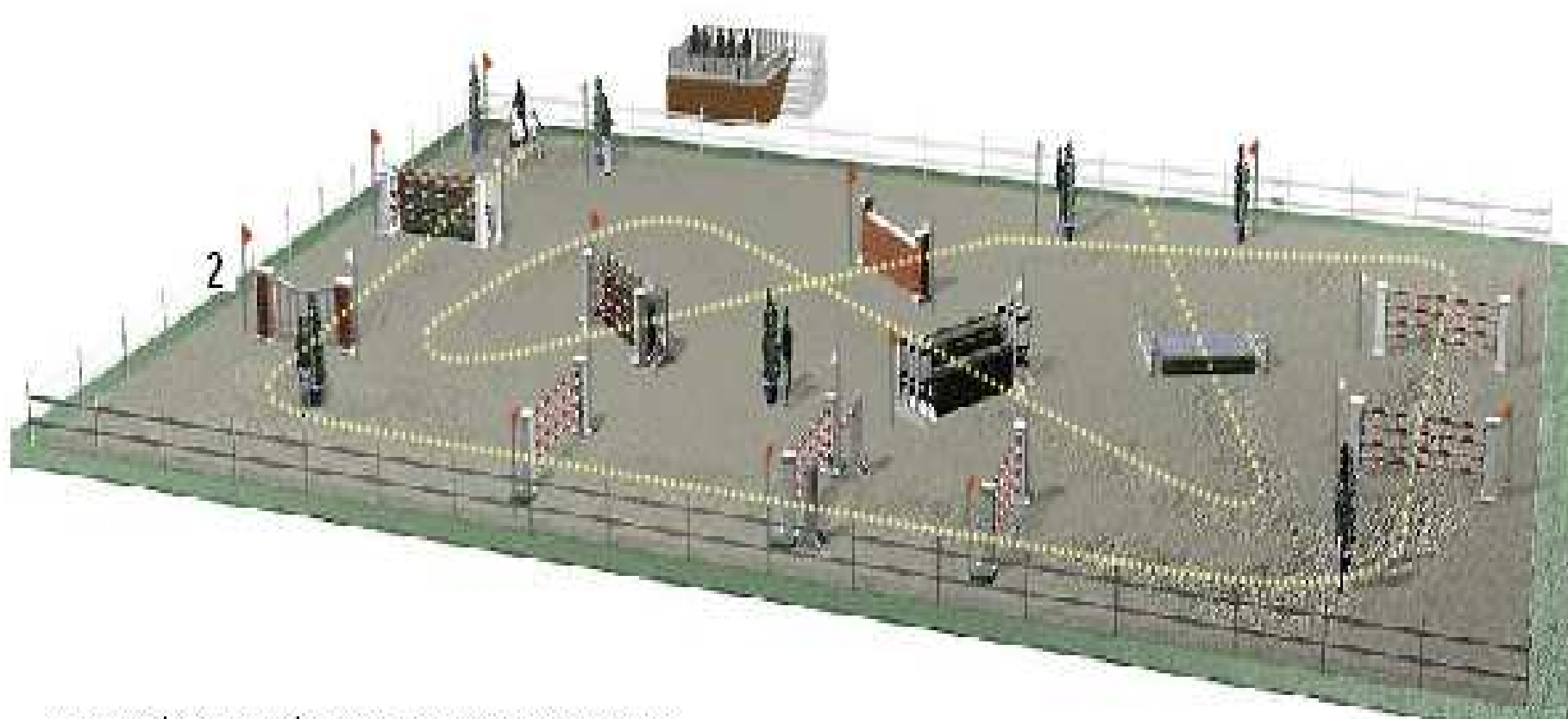

# MATERIAL PARA A SÚA PRÁCTICA



**SELA**



**CHAQUETA**



**PANTALÓN**



**BOTAS**



**LUVAS**

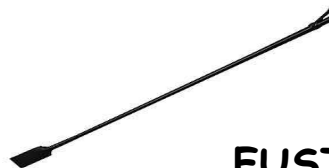

**FUSTA**



**CASCO**

# HÓCKEY



DEPORTE OLÍMPICO DENDE  
LONDRES 1908.

CONSISTE EN METER A  
PELOTA NA PORTARÍA  
CONTRARIA EMPREGANDO UN  
STICK PARA GOLPEALA.



# O CAMPO DE XOGO

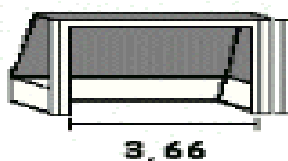

**Medidas**  
 2,1- Porteria  
 hockey hierba

# MATERIAL PARA A SÚA PRÁCTICA

## PROTECTORES

### MANS

Porteiro



### PANTALÓN

Porteiro



### PROTECTOR

BUCAL

### STICK



### BOTAS



### GARDAS

Porteiro



### ARMADURA

Porteiro



### CASCO

Porteiro



### PELOTA



# JUDO

DEPORTE OLÍMPICO DENDE AS  
OLIMPIADAS DE TOKIO EN  
1964.

ARTE MARCIAL DE COMBATE  
CORPO A CORPO.

# O TATAMI

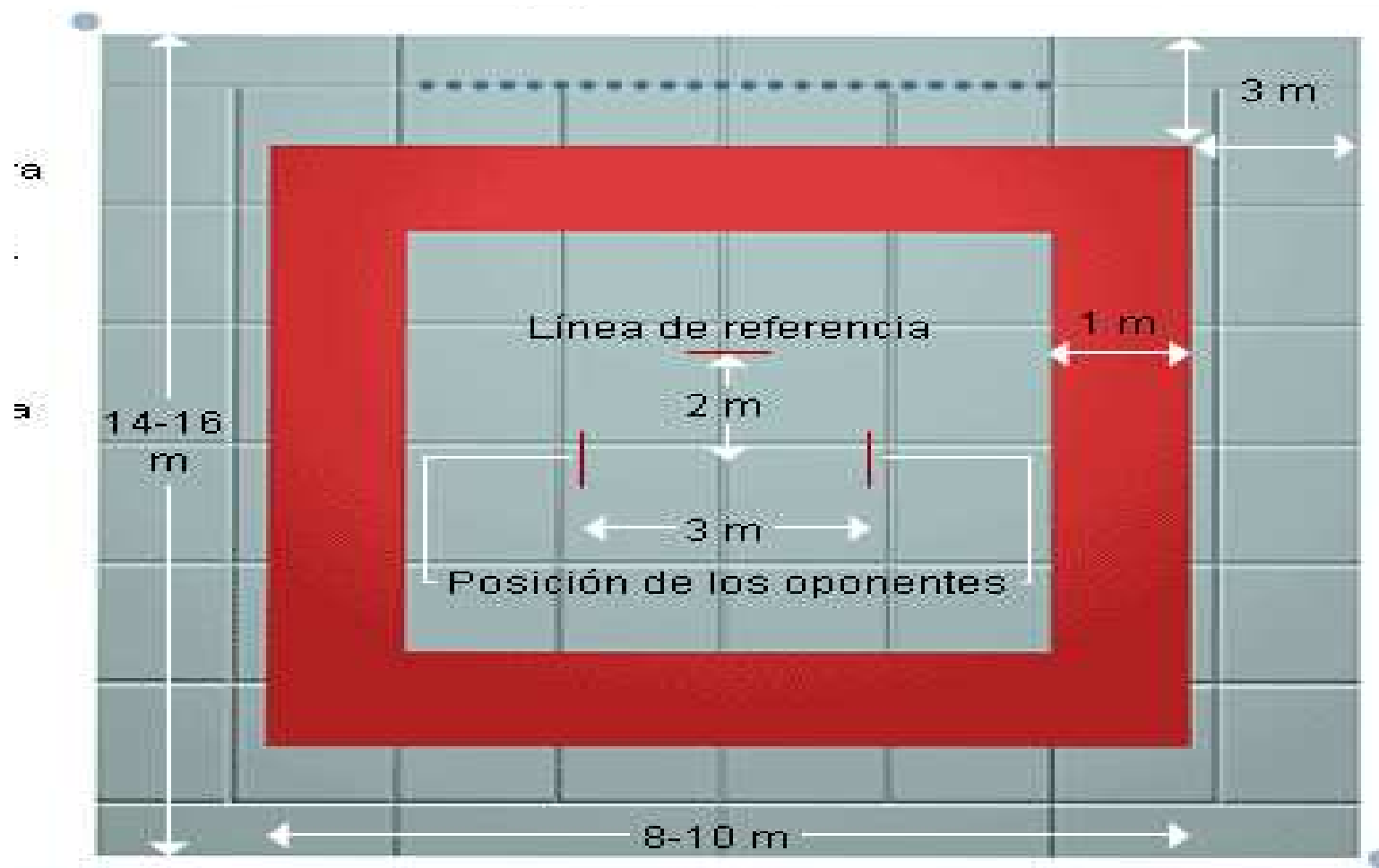

# MATERIAL PARA A SÚA PRÁCTICA



JUDOKI



CINTOS DE JUDO

# LOIITA



**DEPORTE OLÍMPICO NAS  
OLIMPIADAS DE 1896 EN  
ATENAS. VOLVEU A SER  
ADMITIDO EN LONDRES 1908.**

**CADA PARTICIPANTE INTENTA  
DERROTAR AO SEU RIVAL SEN O  
USO DE GOLPES.**

# TAPIZ



# MATERIAL PARA SÚA PRÁCTICA



**BOTAS**



**PROTECTOR ORELLAS**



**VESTIMENTA**



# NATACIÓN

DEPORTE OLÍMPICO DENDE AS  
OLIMPIADAS DE ATENAS DE  
1896.

OS ESTILOS DA NATACIÓN  
SON: CROL, BOLBORETA,  
BRAZA E ESPALDA.

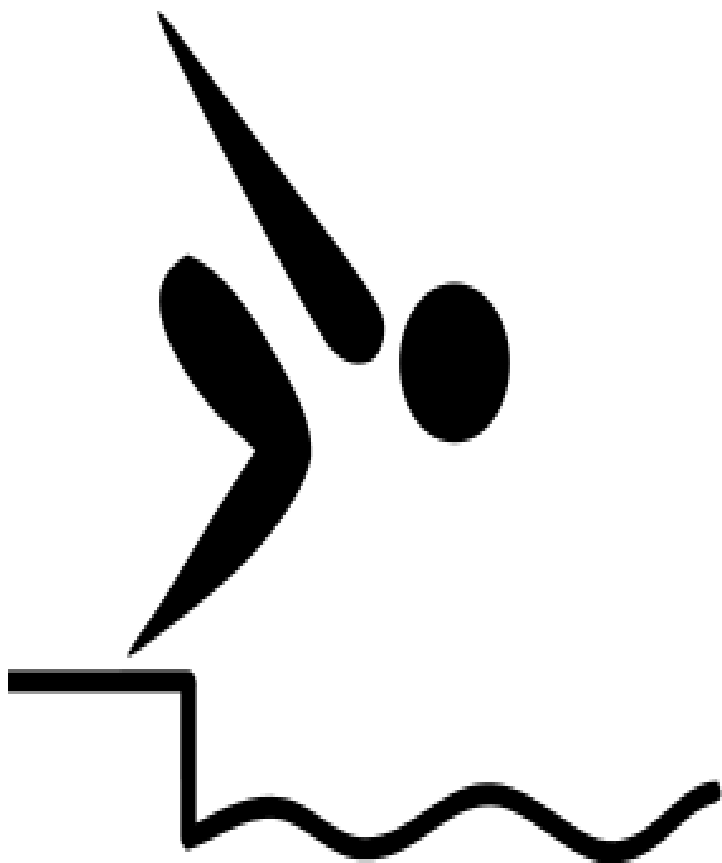

# A PISCINA

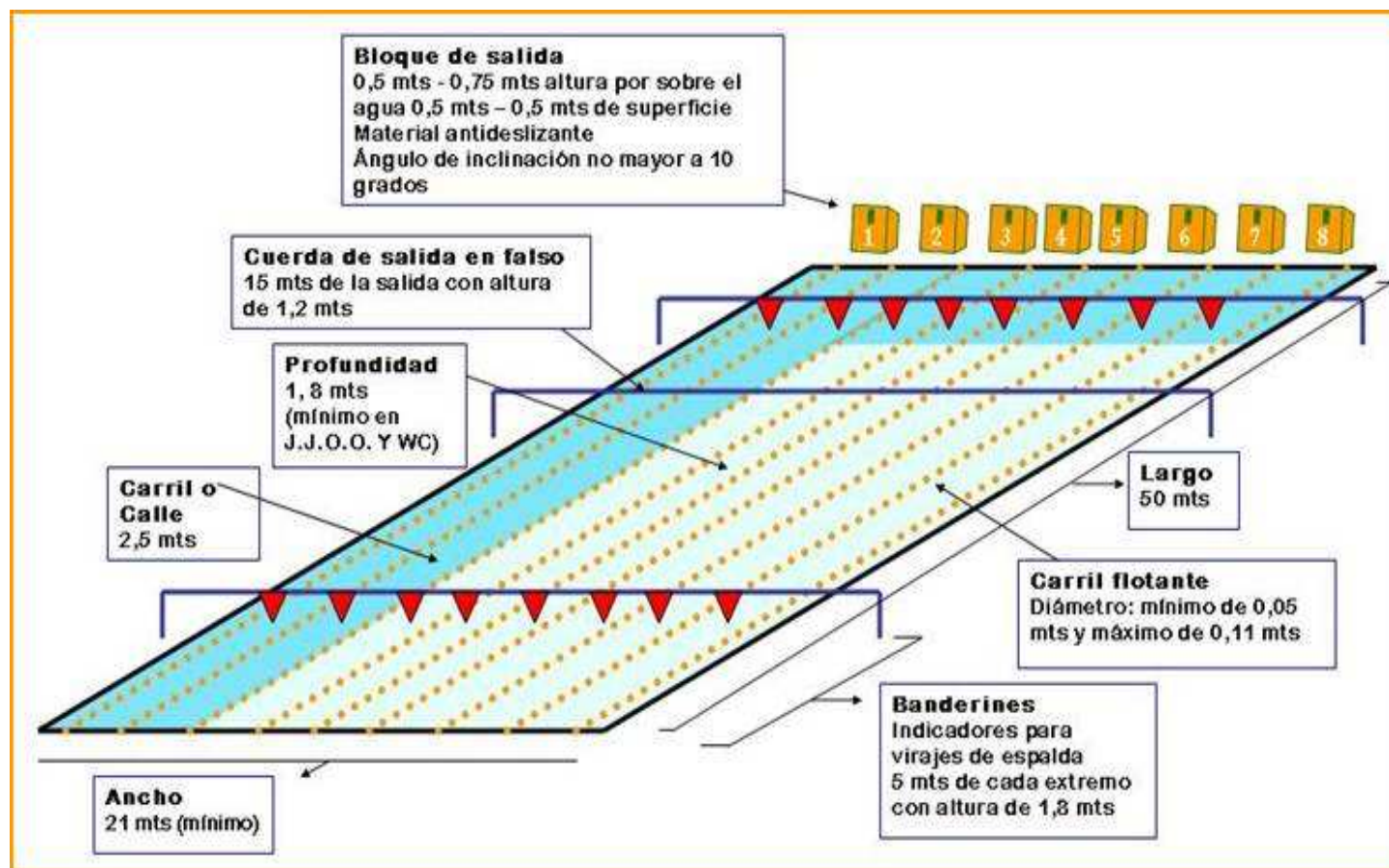

# MATERIAL PARA A SÚA PRÁCTICA



**GORRO**



**BAÑADOR  
(Muller)**



**BAÑADOR  
(Home)**



**GAFAS**

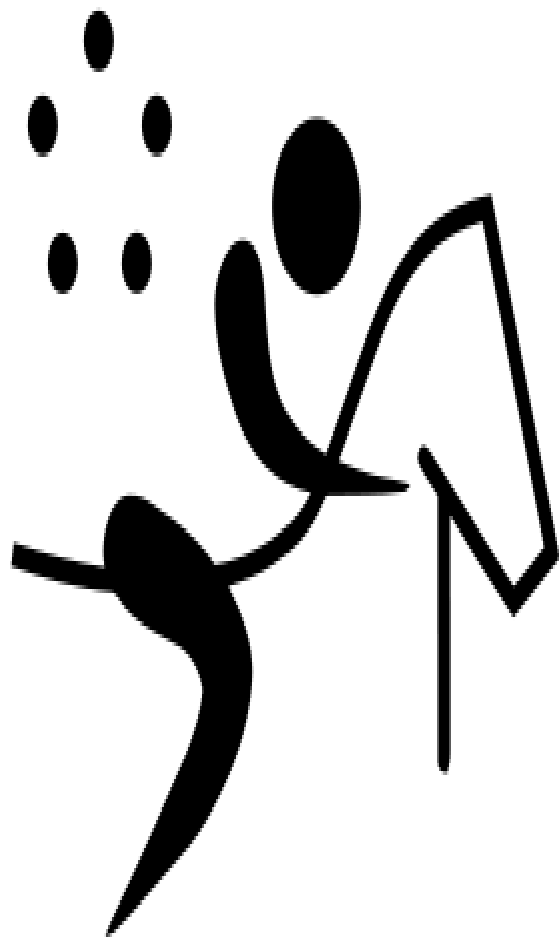

# PENTATLÓN MODERNO

DEPORTE OLÍMPICO DENDE AS OLIMPIADAS DE ESTOCOLMO 1912.

CONSTA DE CINCO PROBAS: TIRO CON PISTOLA , ESGRIMA , NATACIÓN , EQUITACIÓN DE OBSTÁCULOS E CARREIRA A PÉ.

# MATERIAL PARA A SÚA PRÁCTICA



**PISTOLA (TIRO)**



**ESPADA (ESGRIMA)**



**NEOPRENO  
(NATACIÓN)**



**SELA (HÍPICA)**



**CALZADO  
(CARREIRA)**

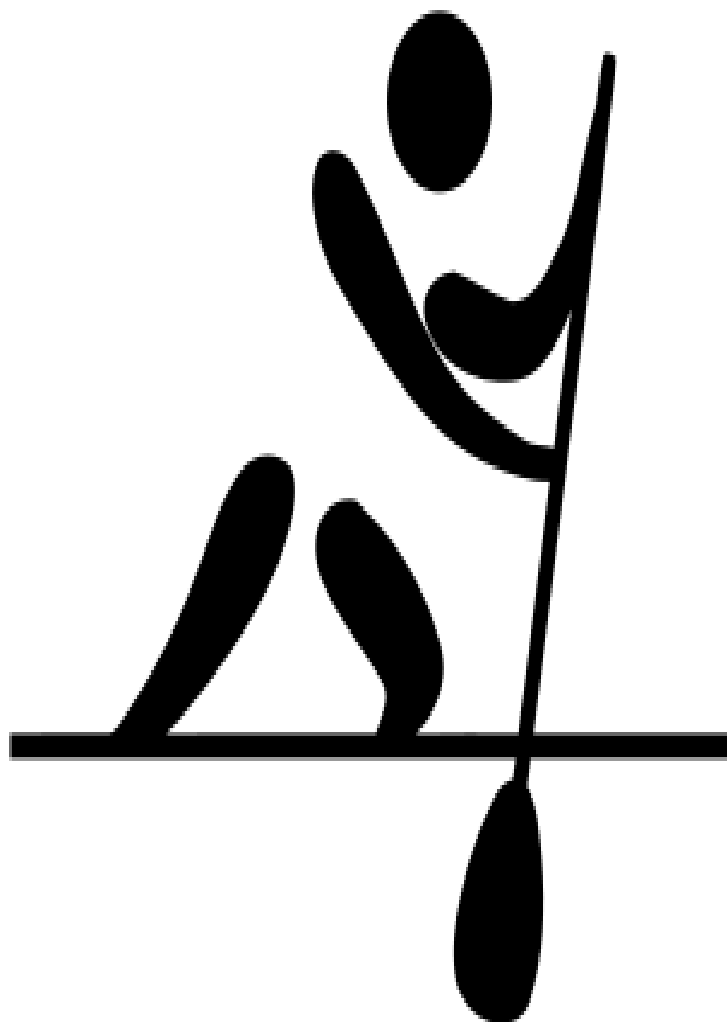

# PIRAGÜISMO

DEPORTE OLÍMPICO DENDE AS  
OLIMPIADAS DE BERLÍN 1936.

O PIRAGÜISMO É UN DEPORTE  
ACUÁTICO NO QUE  
PROPÚLSASE A EMBARCACIÓN  
CUNHA PA.

# CAMPO DE REGATAS

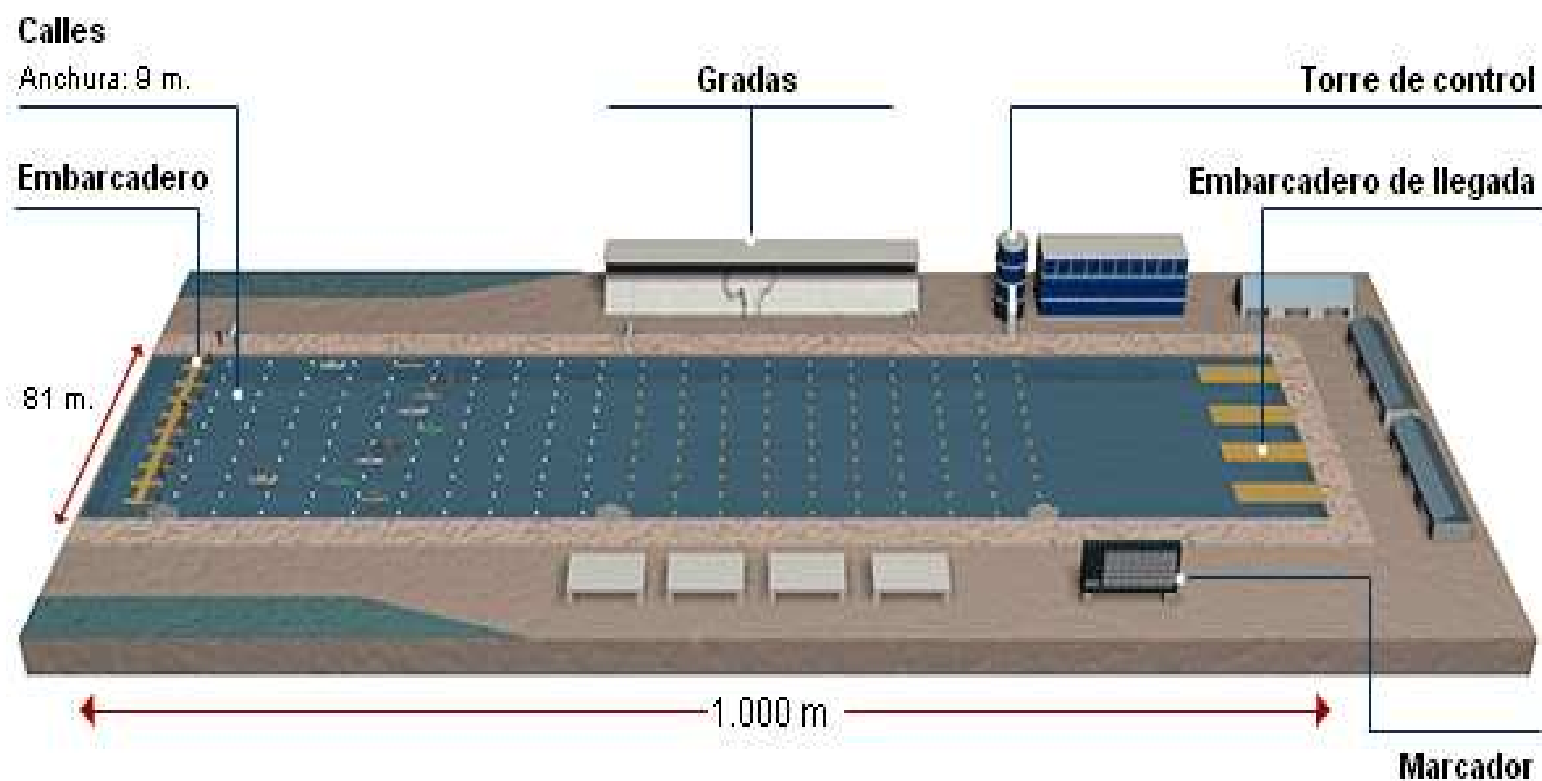

# MATERIAL PARA A SÚA PRÁCTICA

PIRAGUA

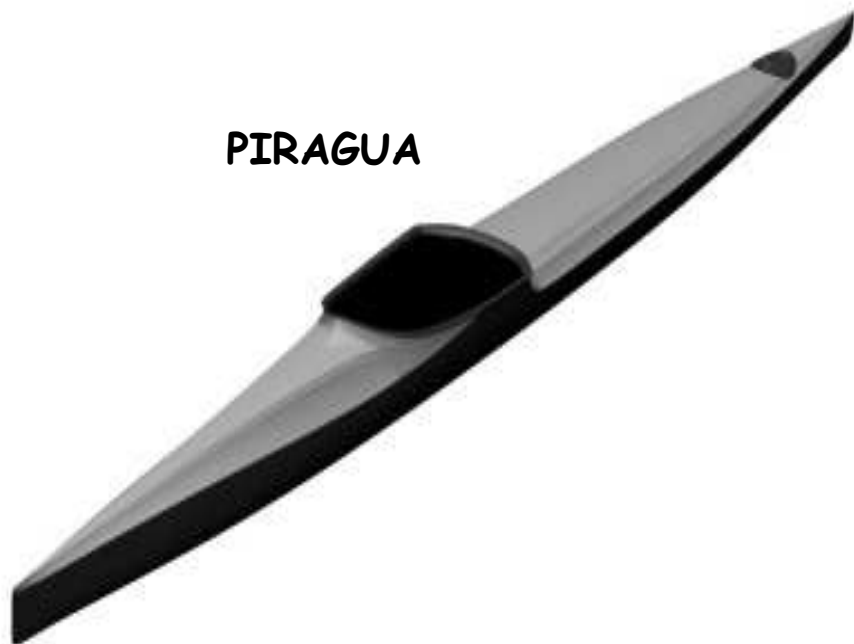

PA



ESCARPÍNS



VESTIMENTA





# REMO

DEPORTE OLÍMPICO DENDE AS OLIMPIÁDAS DE ATENAS 1896.

O REMO ESTÁ FORMADO POR UN CONXUNTO DE DISCIPLINAS DEPORTIVAS QUE CONSISTE NA PROPULSIÓN DUNHA EMBARCACIÓN NA AUGA CON OU SEN TIMONEL.

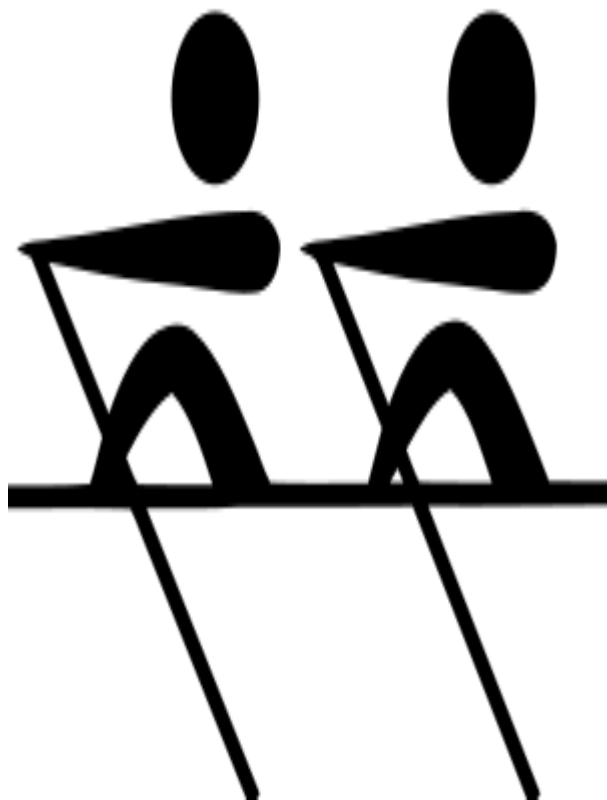

# CAMPO DE REGATA

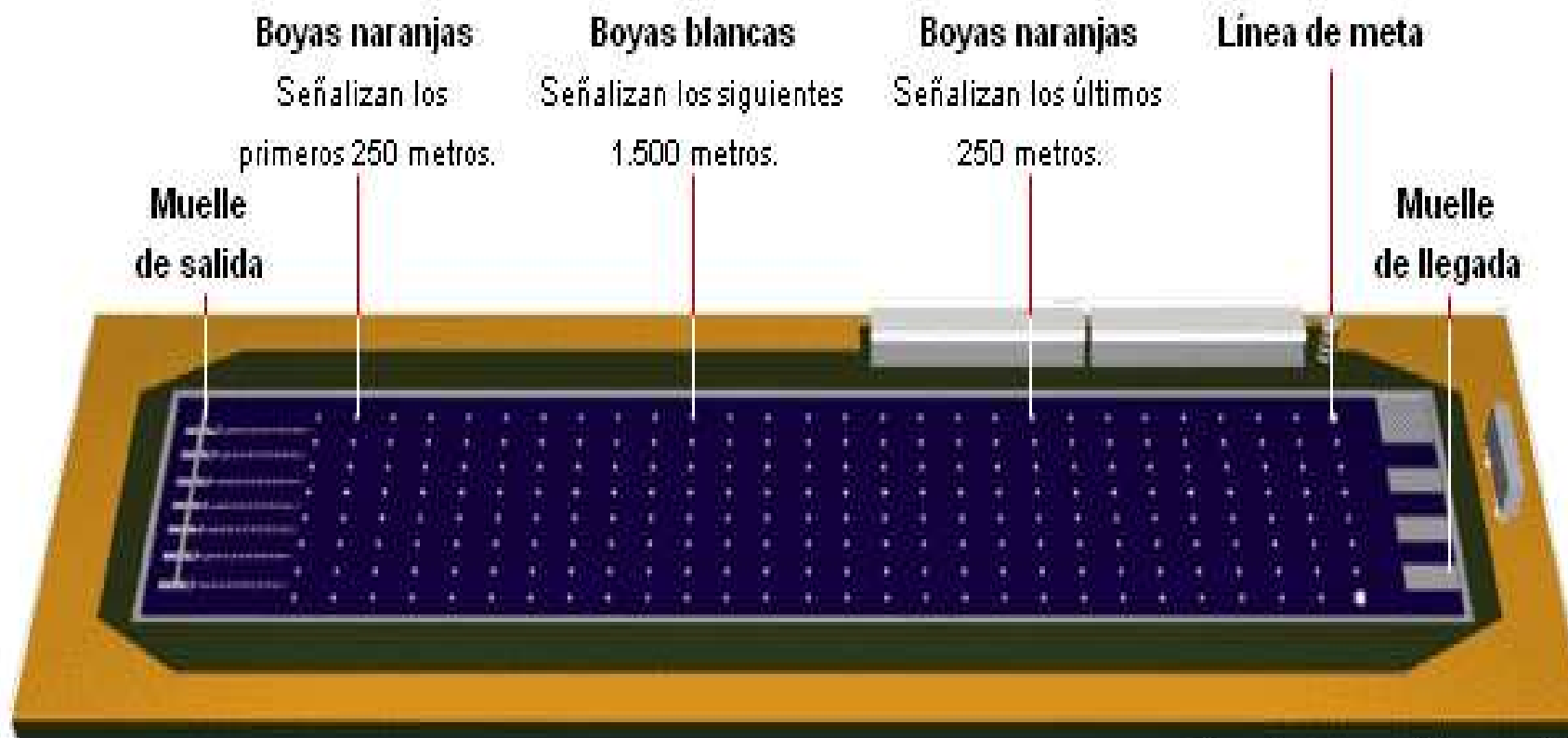

# MATERIAL PARA A SÚA PRÁCTICA



REMO



MAILLOT



ESCARPÍNS



CANOA



# TAEKWONDO

DEPORTE OLÍMPICO DENDE AS OLIMPIADAS DE SIDNEY 2000, FOI DEPORTE DE DEMOSTRACIÓN EN SEÚL 1988 E BARCELONA 1992.

ARTE MARCIAL DE DEFENSA NA QUE SE EMPREGAN SOBRE TODO AS PERNAS E AS PATADAS.

# TATAMI



CEIP VILAXOÁN 2011/2012



# MATERIAL PARA A SÚA PRÁCTICA



**CASCO**

**DOBOK**



**ZAPATILLAS**



**TI  
(CINTO)**



# TENIS



DEPORTE OLÍMPICO DENDE  
ATENAS 1896 A PARÍS 1924.  
VOLVEU A SER OLÍMPICO EN  
BARCELONA 1992.

O OBXECTIVO É GOLPEAR UNHA  
PELOTA PARA QUE DE DOUS  
BOTES NO CAMPO CONTRARIO.

# A PISTA

largo para los partidos individuales.

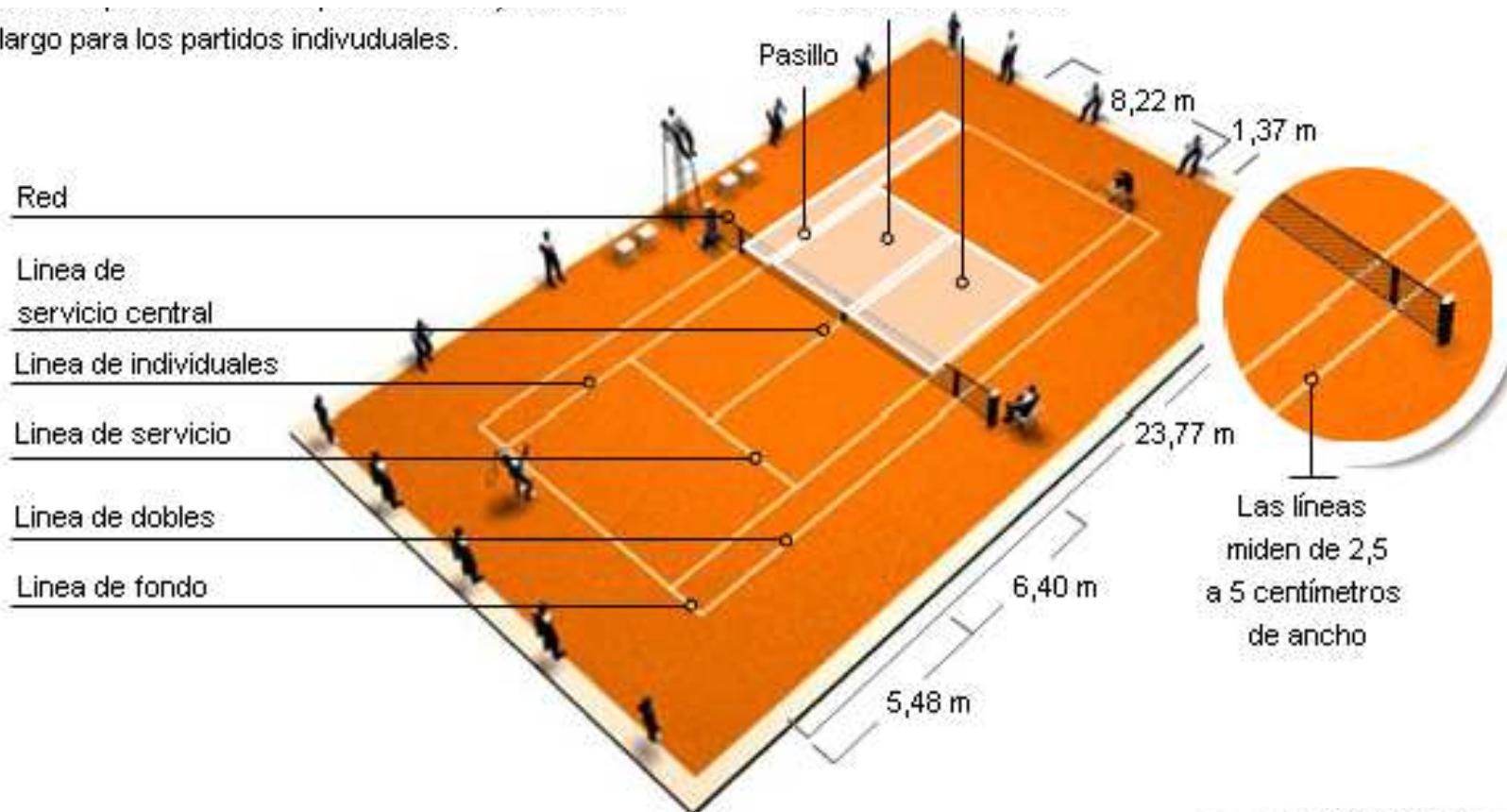



# MATERIAL PARA A SÚA PRÁCTICA



**PELOTA**



**CALZADO**



**VESTIMENTA**



**RAQUETA**

# TENIS DE MESA

DEPORTE OLÍMPICO DENDE AS  
OLIMPIÁDAS DE SEÚL NO ANO  
1988.

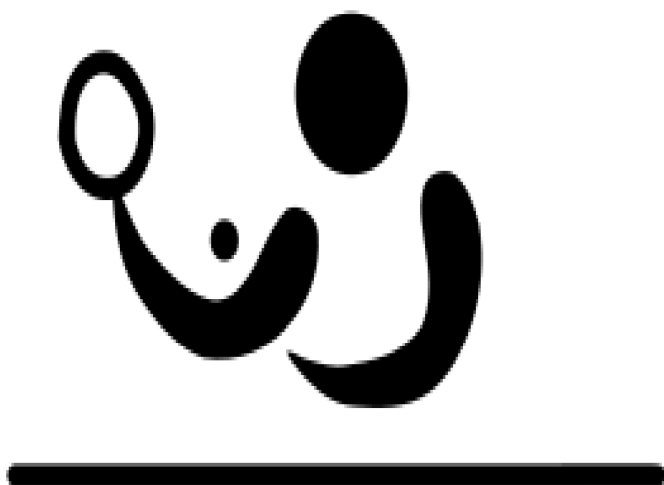

CONSISTE EN GOLPEAR A  
PELOTA PARA QUE CAIA NO  
CAMPO CONTRARIO TRAS  
PASAR A REDE.

# MESA DE XOGO

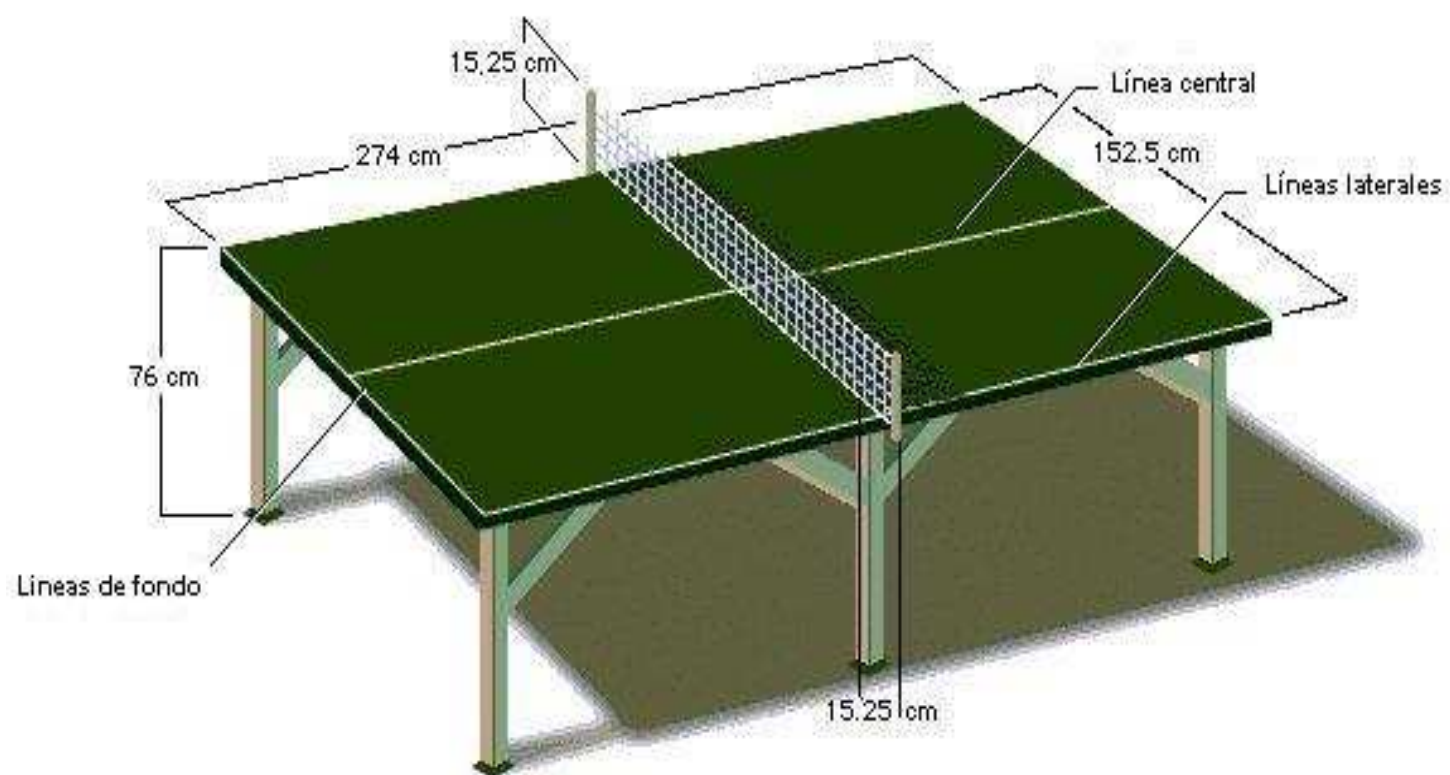

# MATERIAL PARA A SÚA PRÁCTICA

RAQUETA



PELOTAS



EQUIPACIÓN



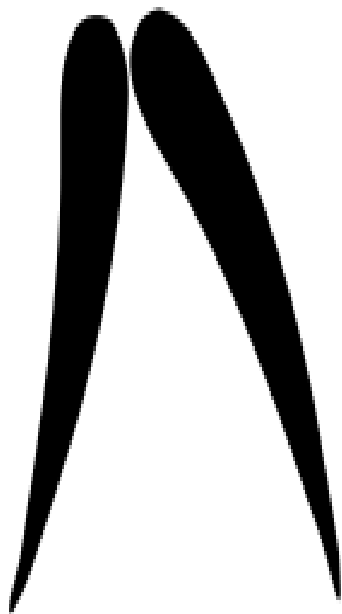
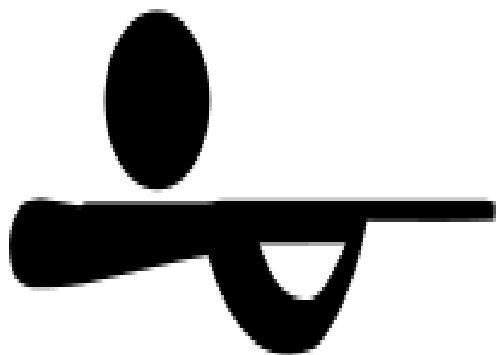

# TIRO

DEPORTE OLÍMPICO DENDE AS  
OLIMPIADAS DE 1896 EN  
ATENAS.

DEPORTE QUE IMPLICA POÑER A  
PROBA A PRECISIÓN E A  
CONCENTRACIÓN NO MANEXO  
DUN ARMA DE FOGO OU DE AIRE  
COMPRIMIDO.

# FOSO DE TIRO

## Foso

Es la modalidad más popular. Hay que romper cada plato con alguno de los dos cartuchos. En las competiciones olímpicas se realizan 5 series de 25 platos cada una, más la final de 25 platos para a los 6 mejores clasificados.

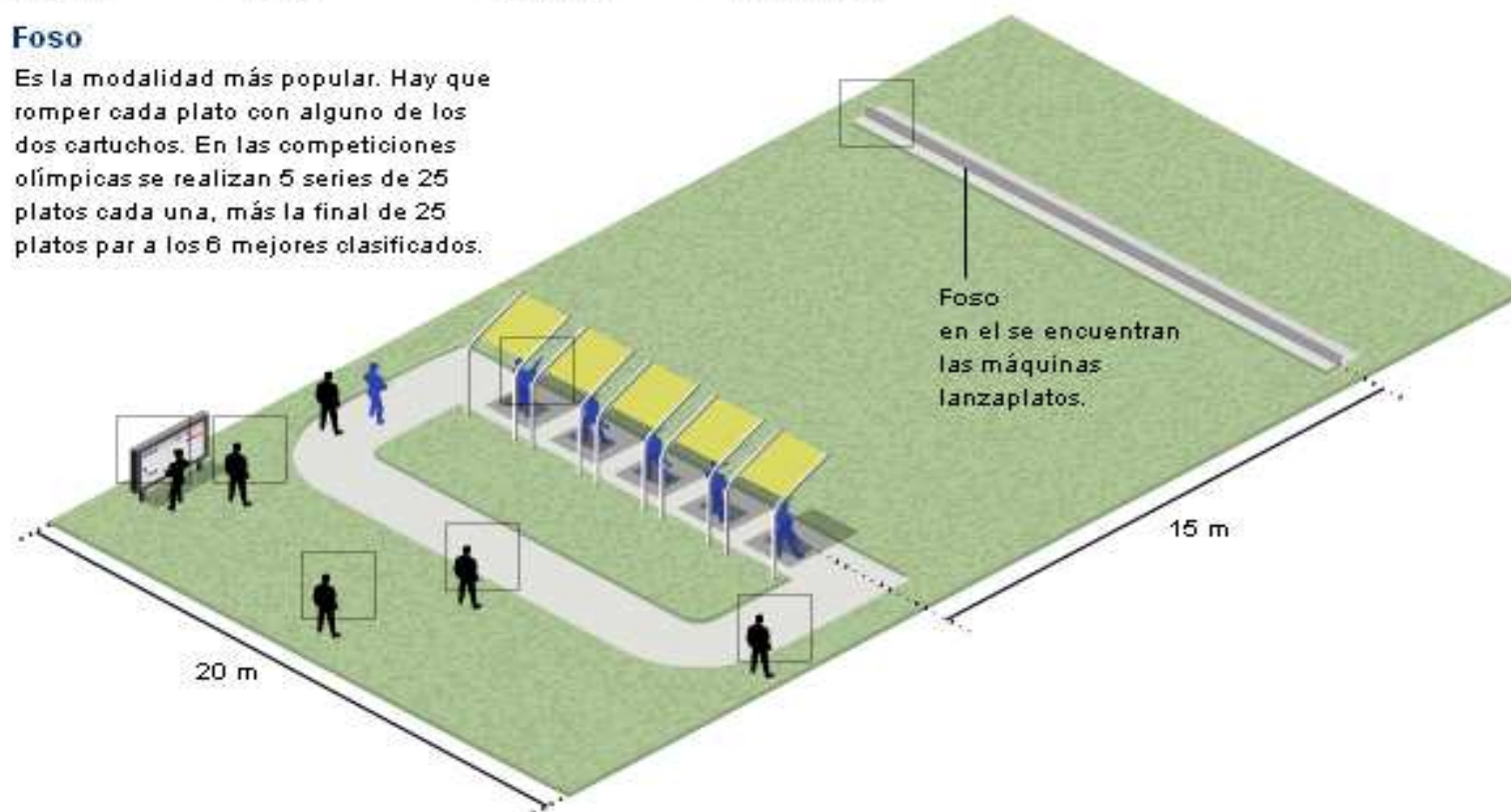



# MATERIAL PARA A SÚA PRÁCTICA



**PISTOLA**



**CARABINA**



**DIANA**



**PRATO**



**CASCOS**



**GAFAS**



# TIRO CON ARCO

DEPORTE OLÍMPICO NAS OLIMPIADAS DE 1900, 1904, 1912 E 1920. VOLVEU A SER OLÍMPICO EN MÚNICH 1972.

O OBYECTIVO É ACERTAR O MÁIS PRETO POSIBLE DO CENTRO DA DIANA PARA OBTER O MAIOR NÚMERO DE PUNTOS.



# O CAMPO DE TIRO

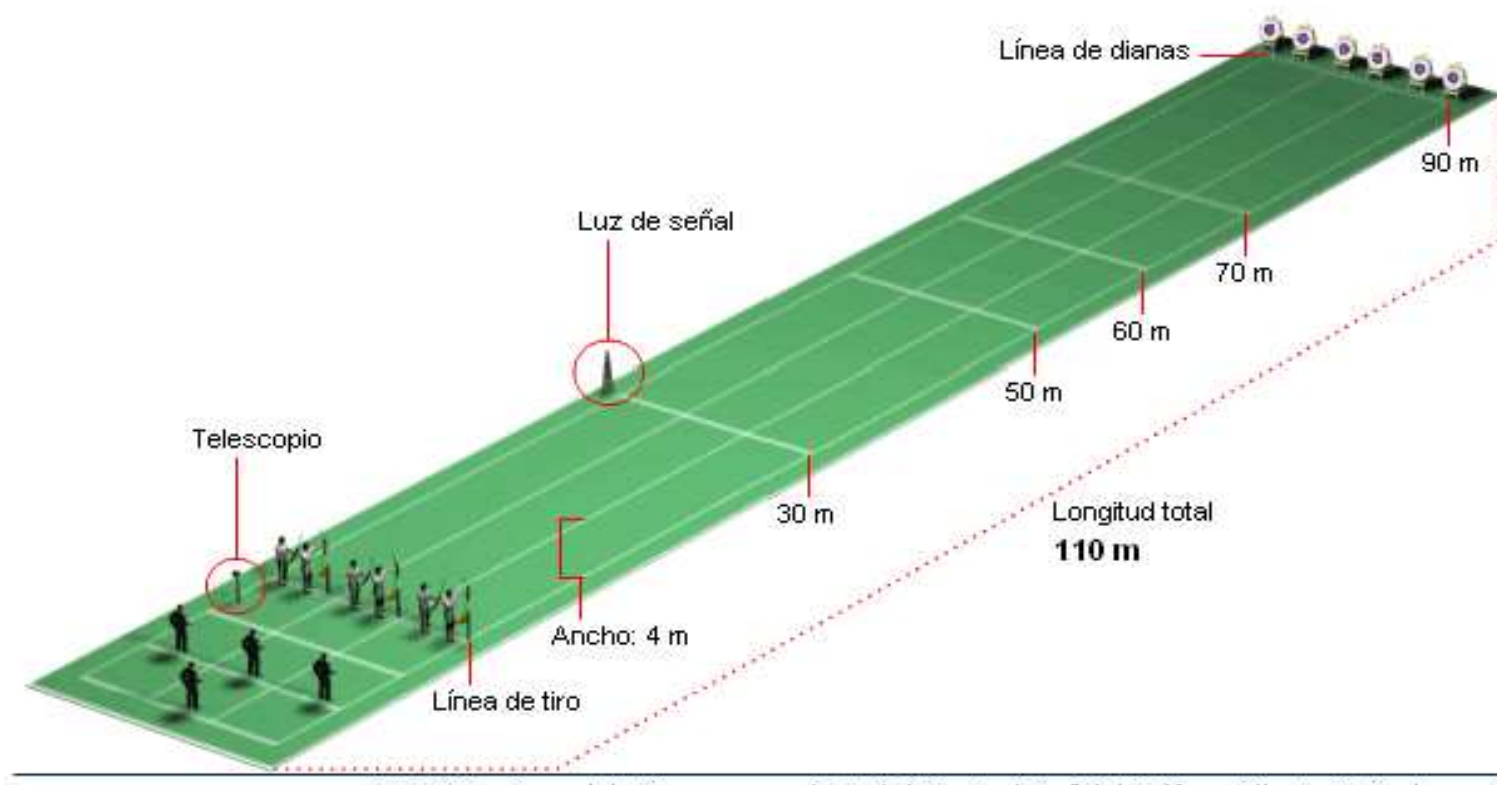

# MATERIAL PARA A SÚA PRÁCTICA



**DIANA**



**ARCO E FRECHAS**



**PROTECTOR**

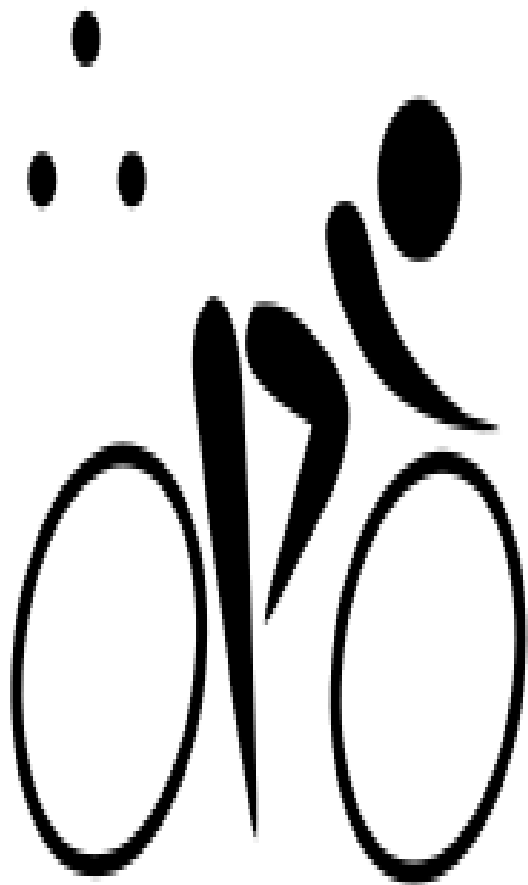

# TRIATHLÓN

DEPORTE OLÍMPICO DENDE AS  
OLIMPIÁDAS DE SIDNEY 2000.

DEPORTE QUE REÚNE TRES  
DISCIPLINAS: CICLISMO,  
NATACIÓN E ATLETISMO.

# CIRCUÍTO



CEIP VILAXOÁN 2011/2012

# MATERIAL PARA A SÚA PRÁCTICA



**BAÑADOR**



**GORRO**



**GAFAS**



**BICICLETA**



**CASCO**



**CALZADO  
CARREIRA**



**VESTIMENTA  
CARREIRA**



**CALZADO  
CICLISMO**



**MAILLOT**



# VELA

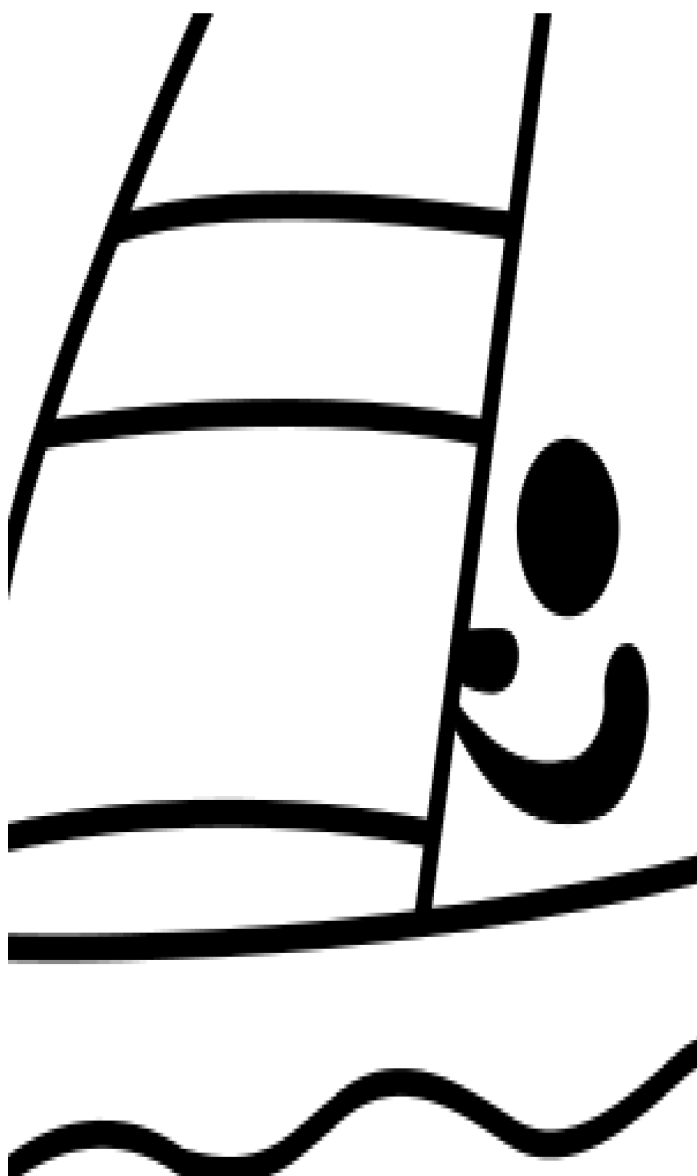

DEPORTE OLÍMPICO DENDE AS OLIMPIÁDAS DE PARÍS 1900 AÍNDA QUE NON SE DISPUTOU EN SAN LUÍS 1904.

DEPORTE NÁUTICO NO QUE O BARCO É PROPULSADO POLA ACCIÓN DO VENTO SOBRE AS VELAS.

# CAMPO DE REGATAS

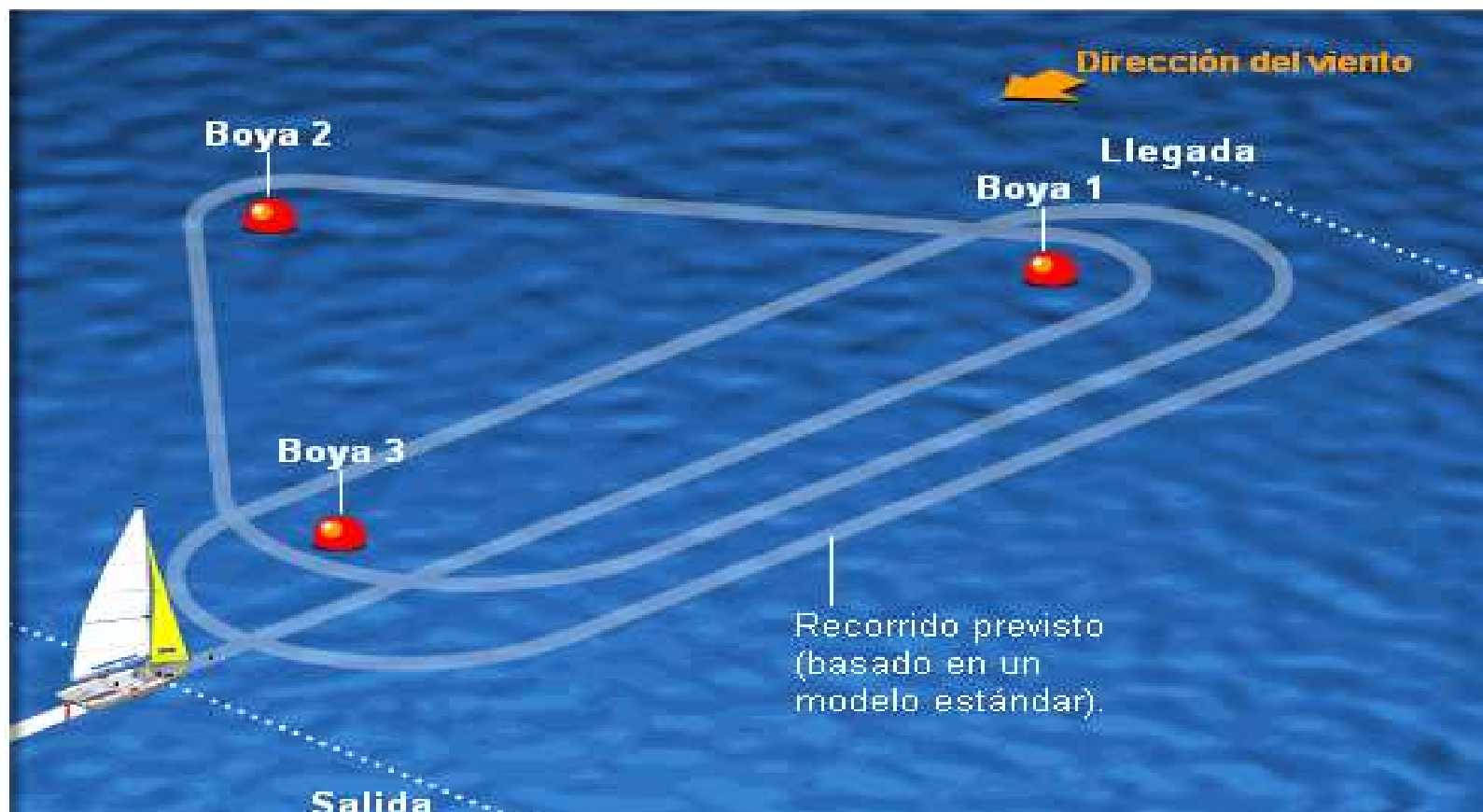



# MATERIAL PARA A SÚA PRÁCTICA



CHALECO



ARNÉS



BOTAS



TRAXE DE  
NEOPRENO

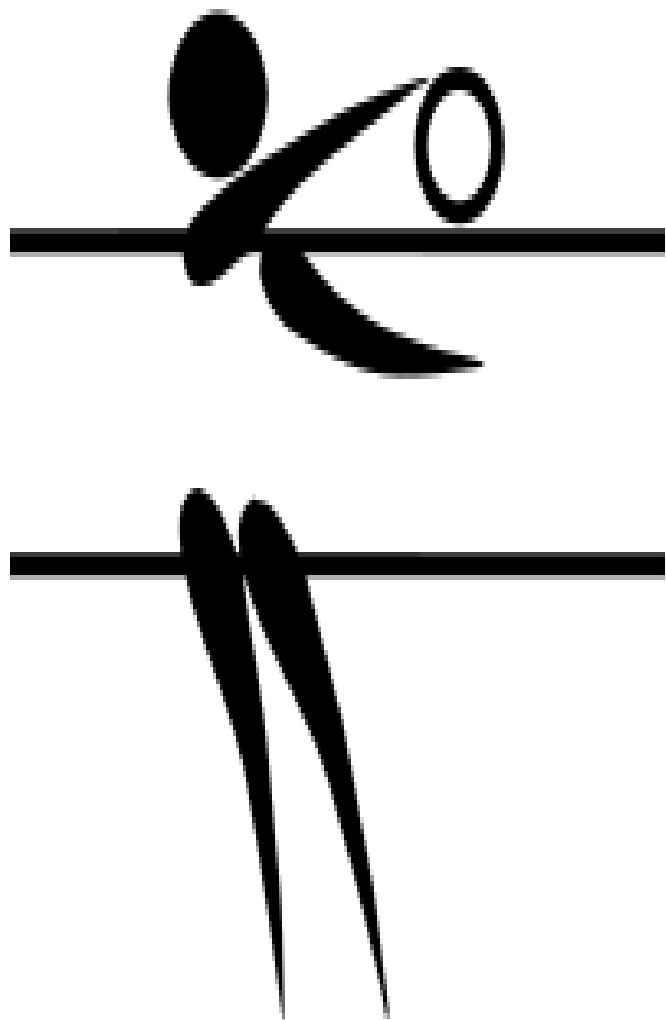

# VOLEIBOL

DEPORTE OLÍMPICO DENDE AS OLIMPIÁDAS DE TOKIO 1964.

DOUS EQUIPOS ENFRÓNTANSE SEPARADO POR UNHA REDE CENTRAL TRATANDO DE PASAR O BALÓN POR RIBA DA MESMA CARA O CHAN CONTRARIO.

# PISTA DE VOLEIBOL

## El campo

Medidas y estructura oficiales para campeonatos.

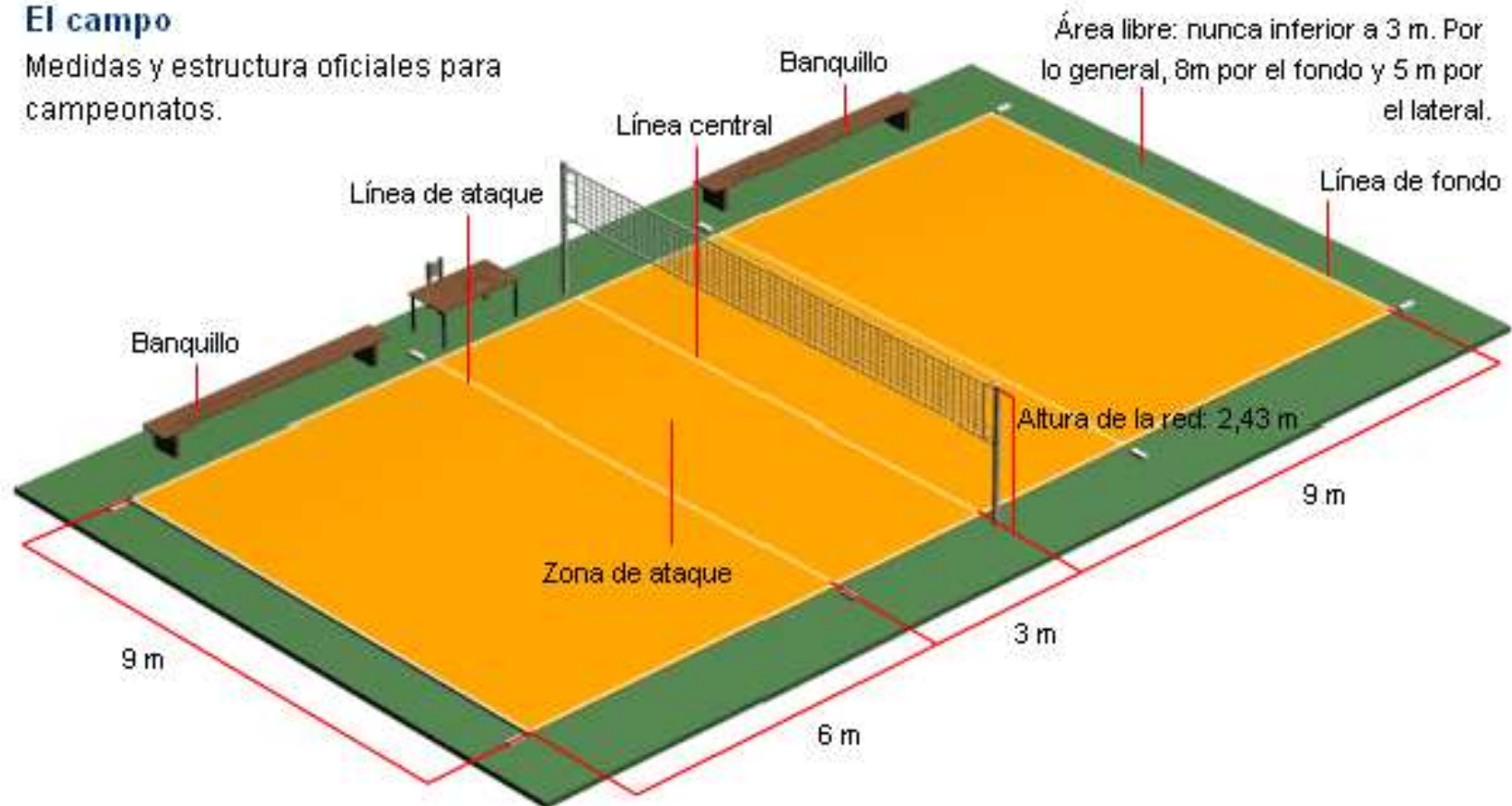

# MATERIAL PARA A SÚA PRÁCTICA



**BALÓN**



**VESTIMENTA**



**CALZADO**

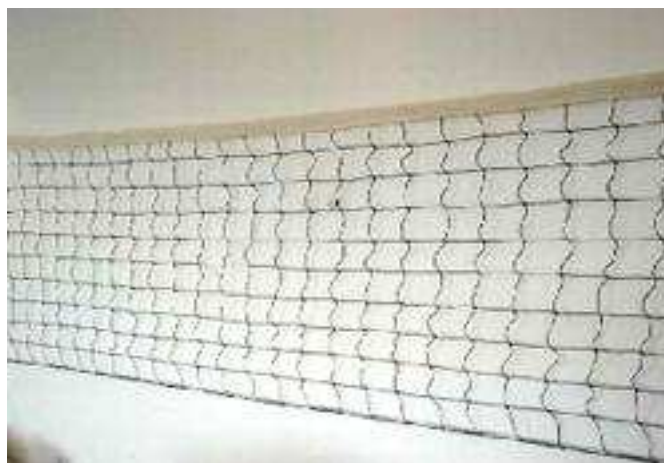

**REDE**



# XIMNASIA

DEPORTE OLÍMPICO DENDE AS  
OLIMPIADAS DE ATENAS 1896  
AÍNDA QUE NON SE  
CONSOLIDOU ATA PARÍS 1924.

NA XIMNASIA ATOPAMOS AS  
MODALIDADES DE: XIMNASIA  
ARTÍSTICA E XIMNASIA RÍTMICA.

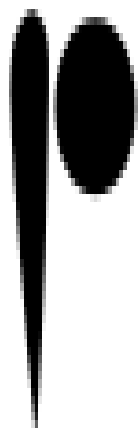



# APARATOS

## CABALO CON ARCOS

XIMNASIA ARTÍSTICA



## BARRA EQUILIBRIO

XIMNASIA ARTÍSTICA



## ASIMÉTRICAS

XIMNASIA ARTÍSTICA

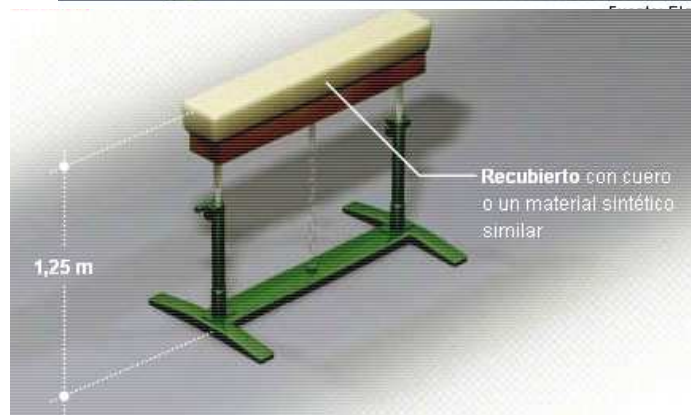
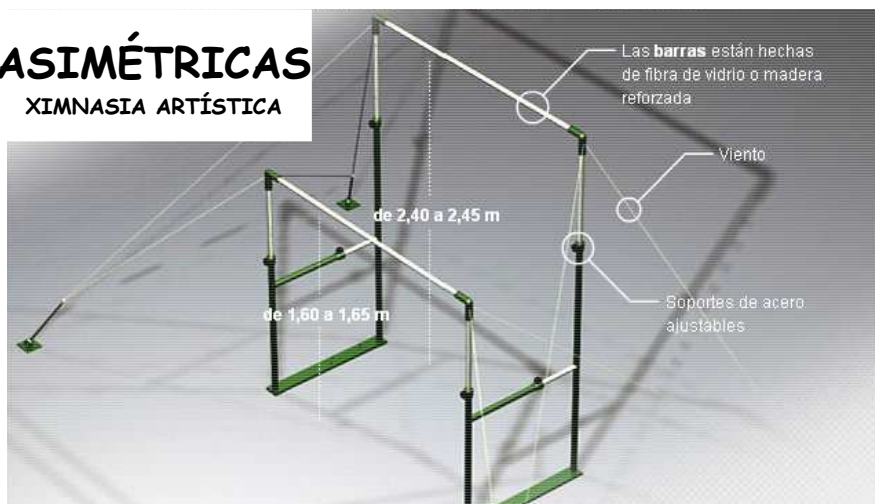

## POLTRO FEMININO

XIMNASIA ARTÍSTICA

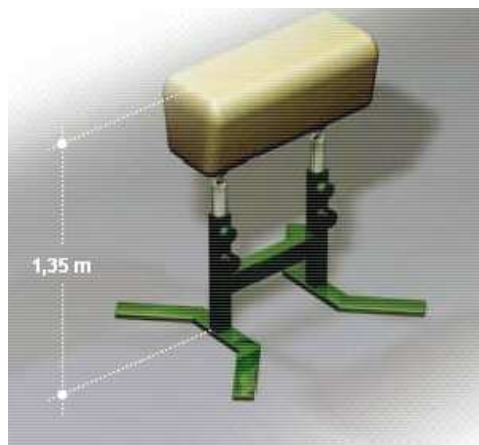

**POLTRO MASCULINO**  
XIMNASIA ARTÍSTICA

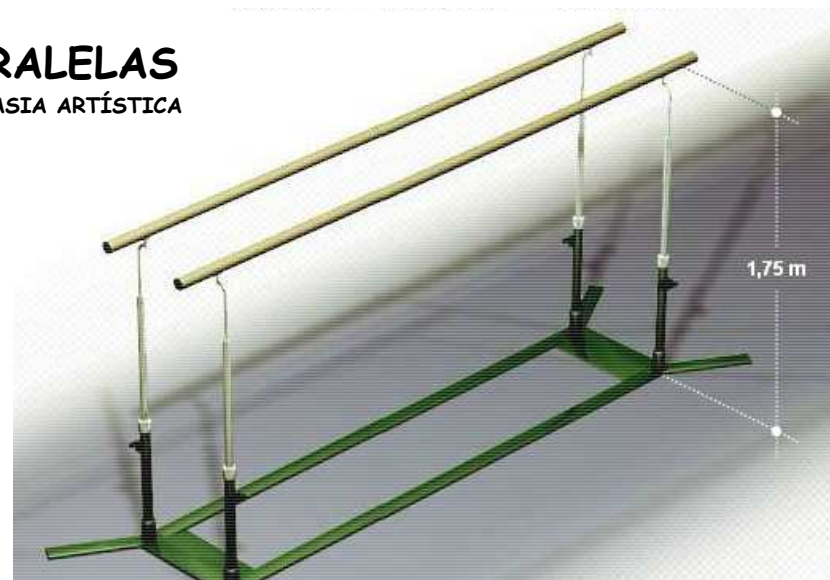

**PARALELAS**  
XIMNASIA ARTÍSTICA

**ARGOLAS**  
XIMNASIA ARTÍSTICA

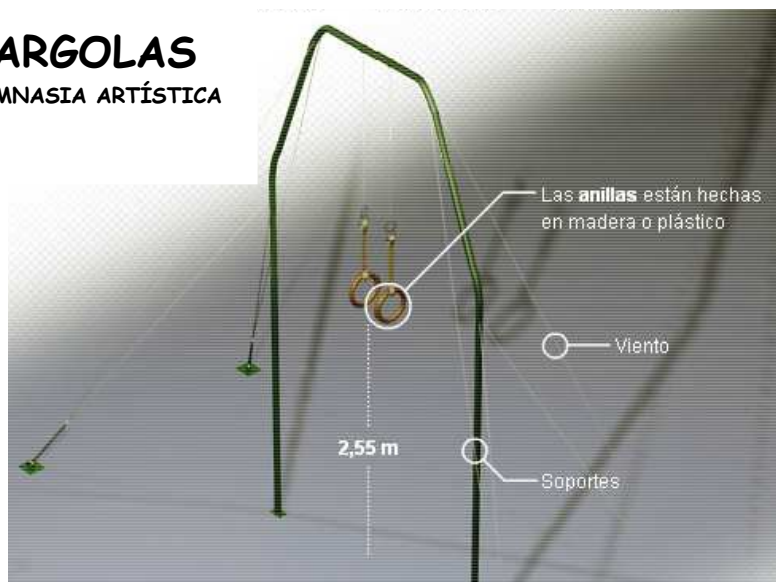

**BARRA FIXA**  
XIMNASIA ARTÍSTICA

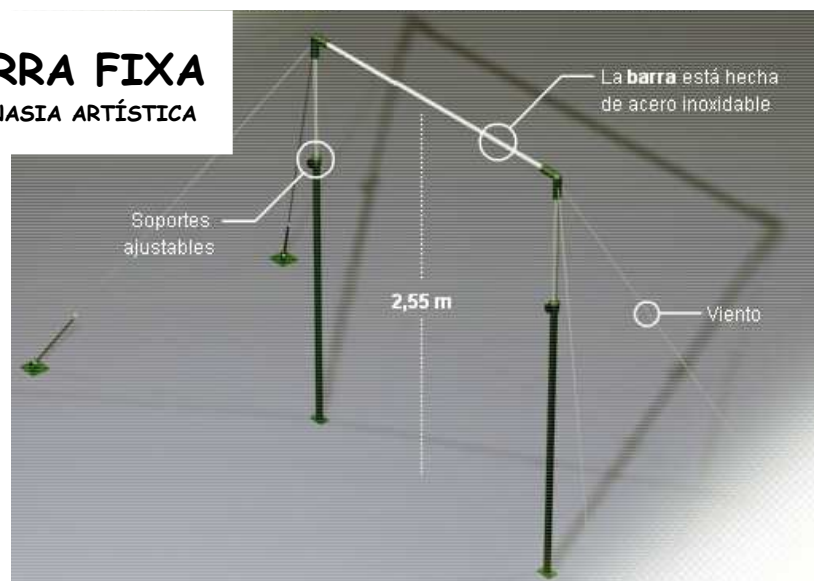



## TAPIZ XIMNASIA ARTÍSTICA

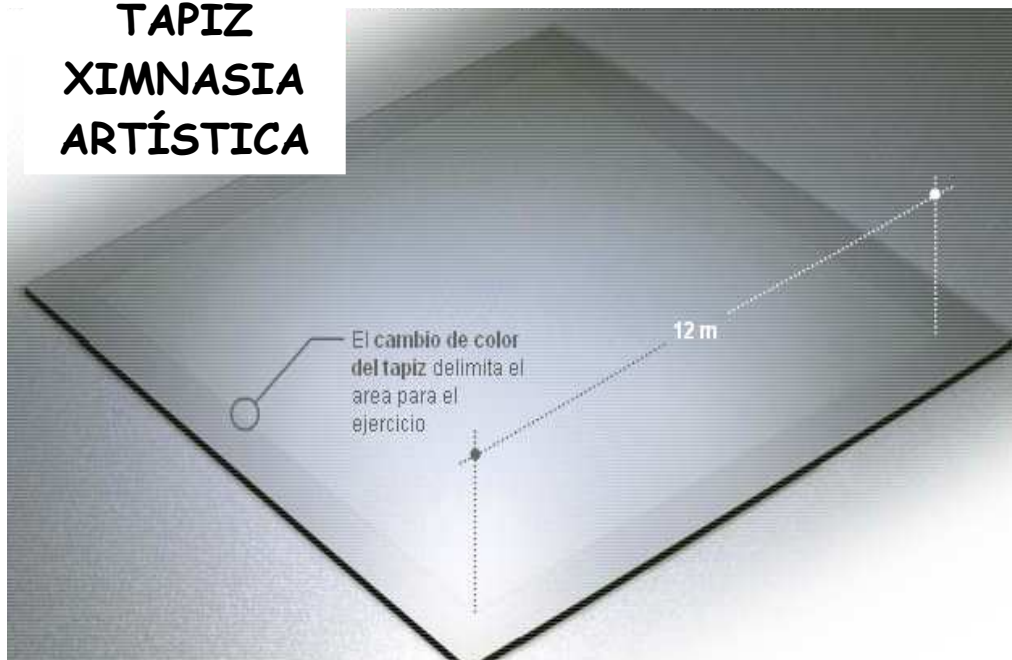

## TAPIZ XIMNASIA RÍTMICA

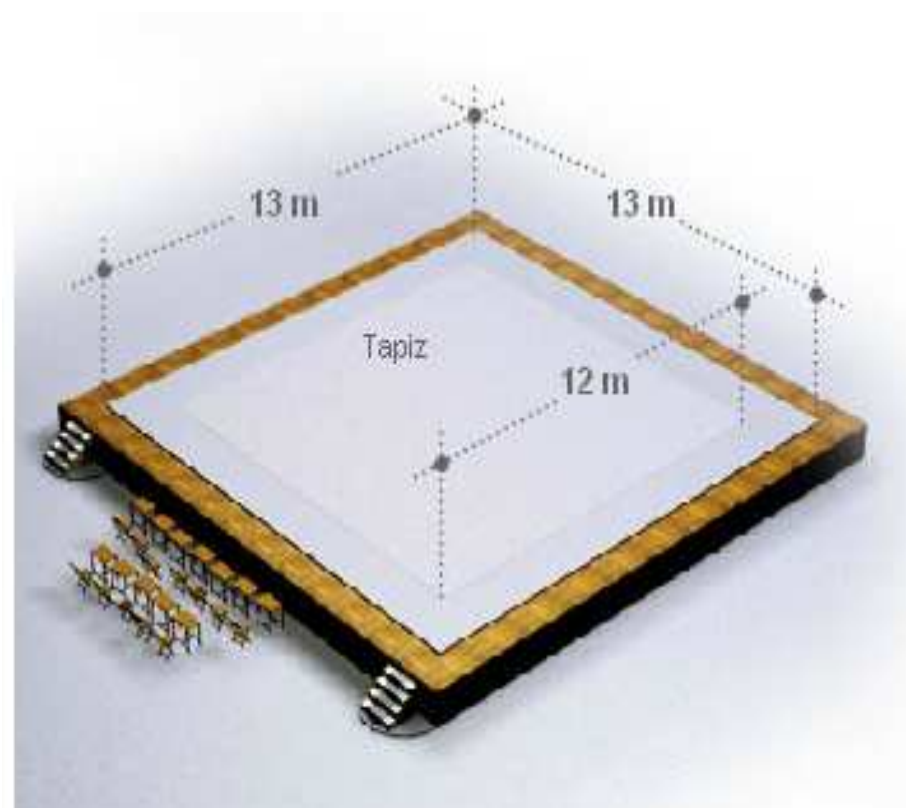

### FITA

XIMNASIA RÍTMICA

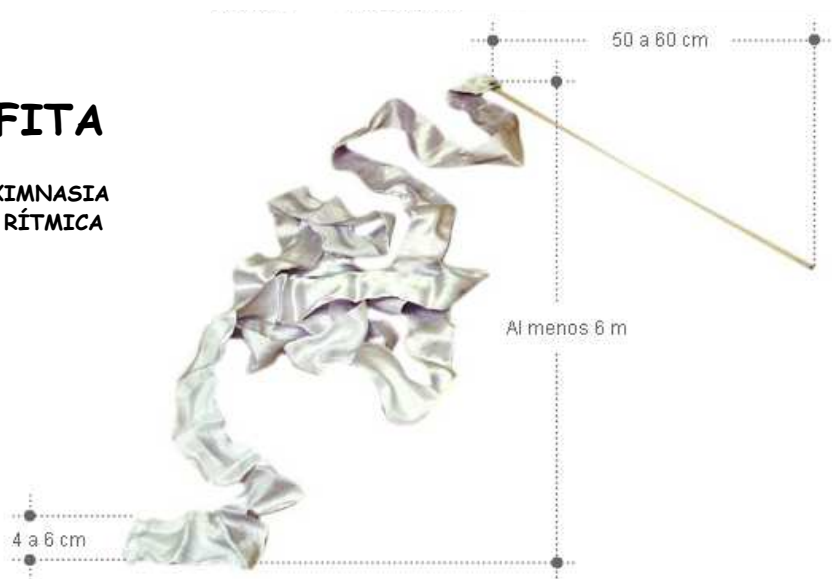

### PELOTA

XIMNASIA RÍTMICA



### MAZAS

XIMNASIA RÍTMICA

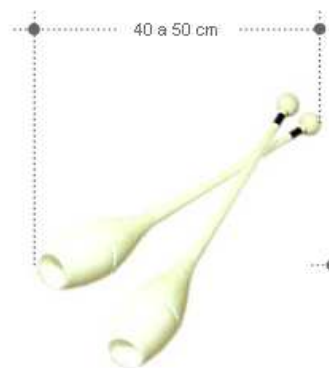

### ARO

XIMNASIA RÍTMICA

### CORDA

XIMNASIA RÍTMICA



# MATERIAL PARA A SÚA PRÁCTICA



**CALLERAS**

**ZAPATILLAS**



**PUNTEIRAS**



**MAILLOT  
CHICAS**



**MAILLOT  
CHICOS**

# BIBLIOGRAFÍA

- TODO OLIMPIADAS: [HTTP://WWW.TODO-OLIMPIADAS.COM/](http://www.todo-olimpiadas.com/)
- WIKIPEDIA: [HTTP://ES.WIKIPEDIA.ORG/WIKI/DEPORTES OLÍMPICOS](http://es.wikipedia.org/wiki/Deportes_Olímpicos)
- EL MUNDO JUEGOS OLÍMPICOS ATENAS 2004:  
[HTTP://WWW.ELMUNDO.ES/JJOO/2004/HTML/GRAFICOS/MARTILLO.HTML](http://www.elmundo.es/jjoo/2004/html/graficos/martillo.html)