

Oxford Activity Sheets

GREAT EXPLORERS

6



OXFORD

GREAT EXPLORERS



Oxford Activity Sheets Contents

Unit	Page	Unit	Page
1 Unit 1		4 Unit 4	
Reinforcement 1	1	Reinforcement 1	19
Reinforcement 2	2	Reinforcement 2	20
Reinforcement 3	3	Reinforcement 3	21
Extension 1	4	Extension 1	22
Extension 2	5	Extension 2	23
Extension 3	6	Extension 3	24
2 Unit 2		5 Unit 5	
Reinforcement 1	7	Reinforcement 1	25
Reinforcement 2	8	Reinforcement 2	26
Reinforcement 3	9	Reinforcement 3	27
Extension 1	10	Extension 1	28
Extension 2	11	Extension 2	29
Extension 3	12	Extension 3	30
3 Unit 3		6 Unit 6	
Reinforcement 1	13	Reinforcement 1	31
Reinforcement 2	14	Reinforcement 2	32
Reinforcement 3	15	Reinforcement 3	33
Extension 1	16	Extension 1	34
Extension 2	17	Extension 2	35
Extension 3	18	Extension 3	36

Carol Barrett

1 Complete. Use the correct form of the verb.

~~cut the grass~~ water the flowers plant seeds pick strawberries feed the birds
make a window box eat a carrot dig a hole



1 Sean is cutting
the grass.



2 Rosie _____



3 Andy _____



4 Karen _____



5 Helen _____



6 Sam _____



7 Mrs Roberts _____



8 Jason _____

2 Look and correct the sentences.



Ruth is feeding the birds.

Ruth isn't feeding the birds. She's feeding the dog.



Bob is planting seeds.



Iria is making a window box.



Jack is eating strawberries.



Amy is picking the flowers.



Dad is watering the grass.

1 Write.

a computer game a kite ~~a book~~ sandwiches a window box
 football strawberries a magazine

a book

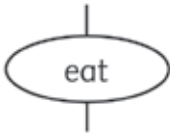
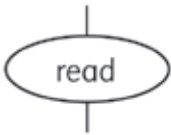

2 Write.



She's eating strawberries.



They're reading a magazine.



3 Look at the picture. Write questions.



Are they eating sandwiches?

Yes, they are.



Yes, she is.



Yes, they are.



Yes, he is.

1 Complete.

beautiful angry tall colourful dangerous small hard

1 The trees are

tall.

2 The man is

3 The flowers are

4 The bees are



5 His kite is

6 The rock is

7 The beetle is

2 Look at the picture. Write True or False.

1 The bee is more dangerous than the butterfly. True

2 The flowers are taller than the trees. _____

3 The man is angrier than the woman. _____

4 The boy's kite is more colourful than the girl's kite. _____

5 The flowers are more beautiful than the trees. _____

6 The rock is harder than the flowers. _____

3 Write about the pictures. Use the adjective in the correct form.

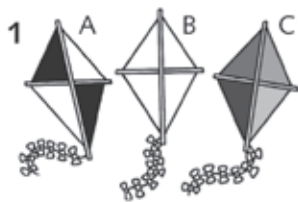

(colourful)

C is the most colourful.



(angry)



(hard)



(useful)

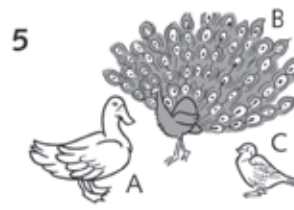

(beautiful)



(tall)

1 Use a dictionary to find the words. Write. **D**

broccoli aubergine ~~cabbage~~ cauliflower bean mushroom



cabbage

2 Use a dictionary to find the words. Write. **D**

lemon ~~cherries~~ apricot grapes pineapple watermelon

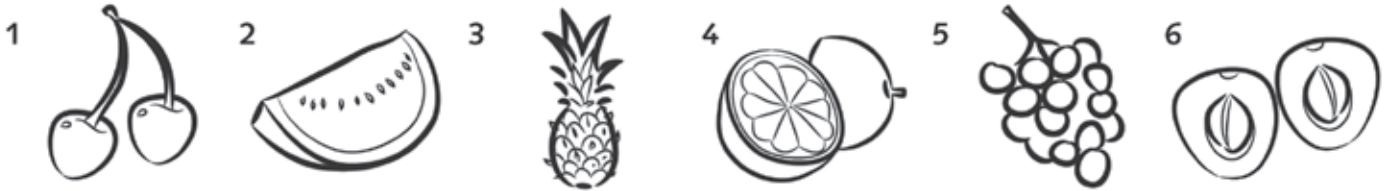

cherries

3 Read and write. Then draw and write two sentences about you.

1 His favourite fruit is cherries.

4 Her favourite vegetable is broccoli.

2 _____

5 _____

3 _____

6 _____

7 My _____

8 My _____

1 Look and write 1, 2 or 3.



- a What are the dogs doing?
 They're playing. 3
- b What's he doing?
 He's sleeping.
- c What's she doing?
 She's riding a bike.

- d Which is the most useful bag?
 The big bag.
- e Which dog is bigger, the black dog or the white dog?
 The black dog.
- f Which is the biggest butterfly?
 The black one.

2 Write questions for your friend to answer. Use all the pictures. Then practise the dialogues.

- 1 *In picture 2, what's the boy doing?*
- 2 _____
- 3 _____
- 4 *In picture 3, who is taller, the girl or the boy?*
- 5 _____
- 6 _____



In picture 1, what are the dogs doing?



They're digging a hole.

1 Read the blog posts. Number the missing sentences.



Amy

We went to the Butterfly and Insect Farm yesterday. We had a great time and we saw lots of mini-beasts! Here are our photos!

More than 500 butterflies live there. It's perfect for them. (1) I love butterflies. I think the Swallowtail is the most beautiful butterfly here. You can see the butterfly feeding table in this picture. (2) The butterflies are drinking the juice from the fruit. They love it!



Simon

This is the Spider Safari. They've got more than 50 different spiders here including some enormous tarantulas! I don't like spiders very much – I'm a bit scared. They aren't dangerous. (3) They aren't moving – I think they're sleeping. My brother loves spiders and I'm taking lots of photos for him. His favourite is the Goliath bird-eating spider. (4) It isn't eating a bird in the photos – thank goodness!

- a They're all in glass cages. c There are lots of their favourite plants and flowers.
 b It's the biggest spider in the world. d It's got pieces of apple and orange on it.

2 Read again and answer the questions for each blog post.

	Amy	Simon
1 Where are they?		
2 How many animals live there?		
3 How do they feel about the butterflies/spiders?		
4 What are the butterflies/spiders doing in the photo?		
5 Which is Amy's/Simon's brother's favourite butterfly/spider?		

3 Write a blog post.

- 1 Imagine you are visiting a Mini-beast Farm. Find a picture of a mini-beast.
 2 Imagine you are looking at the mini-beast. Answer the questions and make notes.

- | | |
|------------------------------------|---|
| - Where are you? | - What are you doing? |
| - How many mini-beasts live there? | - What is your mini-beast doing? |
| - How do you feel? | - Do you know any interesting information about it? |

- 3 Use your notes to write a blog post.
 4 Check your work carefully.
 5 Write out the corrected text and draw a picture.

1 Write.

nurse ~~cleaner~~ doctor shop assistant taxi driver ~~security guard~~ waitress musician



She's a security guard.



He's a cleaner.













2 Complete the sentences. Use the verb in brackets in the correct form.

- 1 (wear a uniform) A security guard wears a uniform.
 A musician doesn't wear a uniform.
- 2 (work in a café) A waitress _____
 A postman _____
- 3 (work in a hospital) A teacher _____
 A nurse _____

3 Read and complete the information about Rosa and Dave. Write about Sue and Tom.

	job?	starts work?	works at weekends?	wears a uniform?	likes his/her uniform?	likes his/her job?
Rosa						
Sue	firefighter	7.00	yes	yes	yes	yes
Tom	postman	5.00	no	yes	no	no
Dave						

Rosa is a waitress. She starts work at nine o'clock and she works at weekends. She wears a uniform. She doesn't like her uniform. She likes her job.

Dave is a doctor. He starts work at two o'clock. He doesn't work at weekends. He doesn't wear a uniform. He likes his job.

1 Sue is _____

2 Tom is _____

1 Complete the sentences with the correct verb form. Complete the crossword.

live ~~lives~~ play plays go goes have has

- 1 Lucy lives in Hill Street.
- 2 She _____ to Glenside Primary School.
- 3 She _____ lunch at school.
- 4 She _____ football in the afternoon.
- 5 Jim and George _____ in River Road.
- 6 They _____ to Riverside Primary School.
- 7 They _____ lunch at school.
- 8 They _____ tennis in the afternoon.

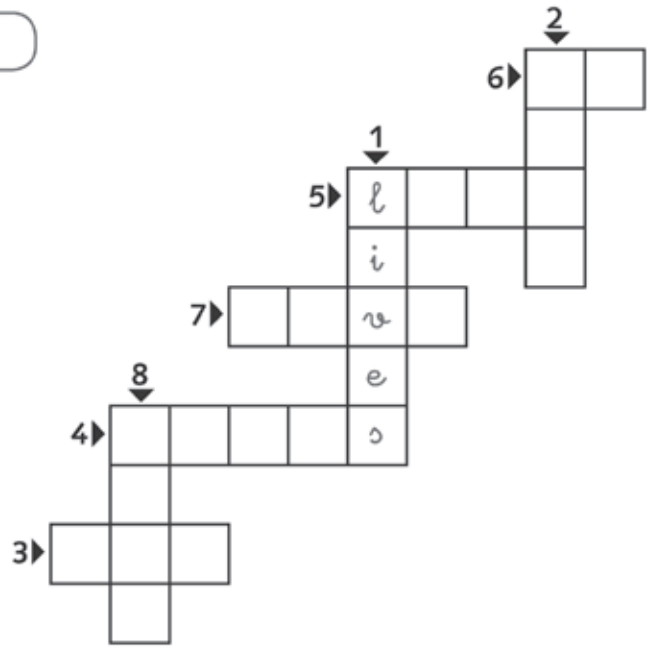

2 Write the answers.

at a restaurant jazz the piano ~~at a dance school~~ the guitar pop

- 1 Where does Bob work?
He works at a dance school.
- 2 What does he play?

- 3 What music does he like?

- 4 Where do Steff and Poppy work?

- 5 What do Steff and Poppy play?

- 6 What music do they like?



3 Write the questions.

- 1 Where does Greg live?
He lives at number 35.
- 2 Where _____ to school?
He goes to Lakeside Primary.
- 3 Where _____
They live at number 37.
- 4 What sport _____
They play badminton.



1 Read and write *True* or *False*.



Sally 	Tom 	Cathy 	James 	Eliza
------------------	----------------	------------------	------------------	------------------

- | | |
|--|---|
| 1 Sally sometimes does her homework.
<u>False</u> | 4 James always does his homework.
_____ |
| 2 Tom never does his homework.
_____ | 5 Eliza usually does her homework.
_____ |
| 3 Cathy sometimes does her homework.
_____ | |

2 Order the words. Then complete the chart for Tony.

- Tony football always . plays Tony always plays football.
- usually homework . He does his _____
- to . goes park He the sometimes _____
- never He . plays piano the _____
- for pizza has lunch . often He _____
- swimming goes He usually . _____

At the weekend	1	2	3	4	5	6
Tony	<i>always</i>					
You						

3 Complete the chart for you. Write.

- | | |
|------------------|---------|
| 1 <u>I</u> _____ | 4 _____ |
| 2 _____ | 5 _____ |
| 3 _____ | 6 _____ |

1 Use a dictionary to find the words. Write. **D**

vet flight attendant cameraman mechanic secretary factory worker



2 Match. Add two more sentences about different jobs. **D**

- | | |
|---|---------------|
| 1 A vet works in <input checked="" type="radio"/> e | a an airport |
| 2 A factory worker works in <input type="radio"/> | b a TV studio |
| 3 A secretary works in <input type="radio"/> | c a factory |
| 4 A mechanic works in <input type="radio"/> | d a garage |
| 5 A flight attendant works in <input type="radio"/> | e a clinic |
| 6 A cameraman works in <input type="radio"/> | f an office |

- 7 _____
- 8 _____

3 Complete each word spider with three more jobs. **D**

a receptionist _____



_____ a doctor



4 Complete the sentences for you. **D**

- 1 I want to be a _____
- 2 I don't want to be a _____ or a _____
- 3 I want to work in a _____
- 4 I don't want to work in a _____ or a _____

1 Look. Complete the questions. Choose ✓ the correct answers.



- 1 Where does he work?
 - a He usually works at the zoo.
 - b He usually works in a school.
- 2 What animals _____?
 - a He never looks after the snakes.
 - b He always looks after the snakes.
- 3 What _____?
 - a He sometimes wears a white or green jacket.
 - b He sometimes wears a black and white jacket and a hat.

2 Write the answers. fruit and vegetables in the shed 3,000 kilos at ten o'clock ~~Africa~~



- 1 Where does Nellie come from?
She comes from Africa.
- 2 What does she eat?

- 3 Where does she sleep?

- 4 What does she weigh?

- 5 What time does she have a bath?

3 Read and circle the correct words.

Koalas live in one country in the world – Australia. All koalas are grey. A lot of people call them koala bears, but they're not bears. They're marsupials – these are animals that have a pouch to carry their babies in, like kangaroos and wallabies. Koala mothers carry

their babies in their pouch until they're about six months old. Koalas eat eucalyptus leaves. They don't like leaves from other types of trees. They get food and liquid from the eucalyptus leaves, so they don't drink a lot of water. Koalas like to sleep. They sleep for 18–20 hours a day!

- 1 You **usually** / **never** find koalas in Europe.
- 2 Koalas are **usually** / **always** grey.
- 3 People **often** / **always** call them koala bears.
- 4 Koalas **sometimes** / **always** have a pouch to carry their babies.
- 5 Koalas **always** / **never** eat leaves from eucalyptus trees.
- 6 Koalas **never** / **sometimes** drink water.
- 7 They **sometimes** / **usually** sleep for 18–20 hours a day.

1 Read. Write the headings for the paragraphs. **D**

Lu's job Amazing bears A safe place

1 _____

There are about 1,500 wild panda bears in China. They don't live in any other part of the world. There are sanctuaries in China because pandas are in danger of extinction. Pandas only eat bamboo, but the bamboo forests are disappearing. Pandas need about 13.5 kilos of bamboo every day! Pandas eat bamboo for about 16 hours every day. When a panda isn't eating, it sleeps.

2 _____

The sanctuary is a special place. Scientists study and look after pandas there. In the future they want to put the pandas back in the bamboo forests. When baby pandas are born they weigh



about 100 grams. They're tiny! Scientists look after them very carefully.

By Chinese tradition they give the baby pandas a name when they're 100 days old.

3 _____

Lu is a teacher and a tourist guide at the sanctuary. Tourists, school children and Chinese families visit the sanctuary. Lu teaches them about pandas. She loves her job. She thinks it's very important to teach people about conservation.

2 Read again. Answer the questions.

- 1 Where do pandas live? In China.
- 2 What do pandas eat? _____
- 3 How many hours does a panda bear sleep?

- 4 How much does a baby panda bear weigh?

- 5 When do they give baby pandas a name?

- 6 What's Lu's job?

- 7 Where does she work?

- 8 What does Lu do?

- 9 Does she like her job?

- 10 What does she think is important?

3 Find out about other animals in danger. Write an article about a sanctuary.

- 1 Choose an animal in danger, for example: tiger, orangutan, chimpanzee, gorilla, lynx, bear.
- 2 Find out about your animal. Write notes.
 - Where do they live?
 - Why are they in danger?
 - What do they eat?
 - What interesting facts do you know?
- 3 Find out about sanctuaries for your animal. Write notes.
 - Where is the sanctuary?
 - What do they do at the sanctuary?
 - Why is it important?
- 4 Use your notes to write about your animal and the sanctuary.

1 Write the questions. Then look and answer.



1 laptop

Has she got a laptop? Yes, she has.

2 charger

3 headphones

4 memory stick

2 What have you got? Answer for you. Use *I've got* and *I haven't got*.

mobile phone calculator DVD player ~~digital camera~~

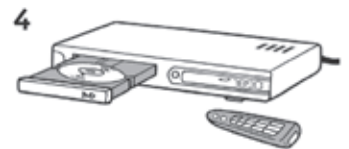

I _____
digital camera.

3 Read and write the names.

Paula	✓	✓	✗	✓	✓	✗
Rosa	✗	✓	✓	✗	✓	✗
Lucy	✓	✗	✓	✗	✗	✓
Amy	✓	✗	✗	✓	✓	✓

- 1 She hasn't got a computer or a memory stick. She's got a mobile phone and a digital camera. She hasn't got headphones. She's got a calculator. What's her name? Rosa
- 2 She's got a computer, but she hasn't got a memory stick. She's got a digital camera and headphones. She hasn't got a mobile phone or a calculator. What's her name?

- 3 She's got a computer and a memory stick. She's got a calculator and headphones. She hasn't got a mobile phone or a camera. What's her name? _____
- 4 She's got a computer and a memory stick. She hasn't got a digital camera or headphones. She's got a calculator. What's her name?

1 Complete.

books school the guitar ~~laptops~~ bikes television
MP3 players pizza photos

- | | |
|-----------------------|-------------------|
| 1 have <u>laptops</u> | 6 go to _____ |
| 2 watch _____ | 7 ride _____ |
| 3 play _____ | 8 take _____ |
| 4 read _____ | 9 listen to _____ |
| 5 eat _____ | |

2 Look at the picture of life in the Stone Age. Find 8 mistakes and write.



- | | |
|---------------------------------|---------|
| 1 <u>They didn't eat pizza.</u> | 5 _____ |
| 2 _____ | 6 _____ |
| 3 _____ | 7 _____ |
| 4 _____ | 8 _____ |

3 Compare your life with life in the Stone Age. Write.

- 1 I learn English. They didn't learn English.
- 2 _____
- 3 _____
- 4 _____
- 5 _____

1 Complete the table.

Infinitive	Past form	Infinitive	Past form	Infinitive	Past form
ride	w		made	use	
	ate	drink			watched
paint			gave	buy	
	had	go			lived
see			played		

2 Complete the sentences with verbs from activity 1. Then write *U* (Ugg), *S* (Steve) or *B* (both).



- He lived in a cave. U
- He played with his brothers and sisters. _____
- He _____ his bike. _____
- He _____ television. _____
- He _____ a mammoth for a pet. _____
- He _____ beautiful pictures on the cave walls. _____
- He _____ to school. _____
- He _____ food at the supermarket. _____
- He _____ meat, fruit and vegetables. _____
- He _____ water. _____

3 Write some more sentences about Steve when he was a boy.

the Queen football for England two sisters a book a computer ~~at 34 Park Road~~



1 (live) He lived at _____
34 Park Road.



2 (have) _____



3 (make) _____



4 (see) _____



5 (write) _____



6 (play) _____

1 Read and label the picture. **D**

There are three grey screens.

One mouse is grey, one is black and one is white.

There are three keyboards.

One keyboard is black, two keyboards are grey.

The printer is white.

The scanner is black.

There are six speakers.

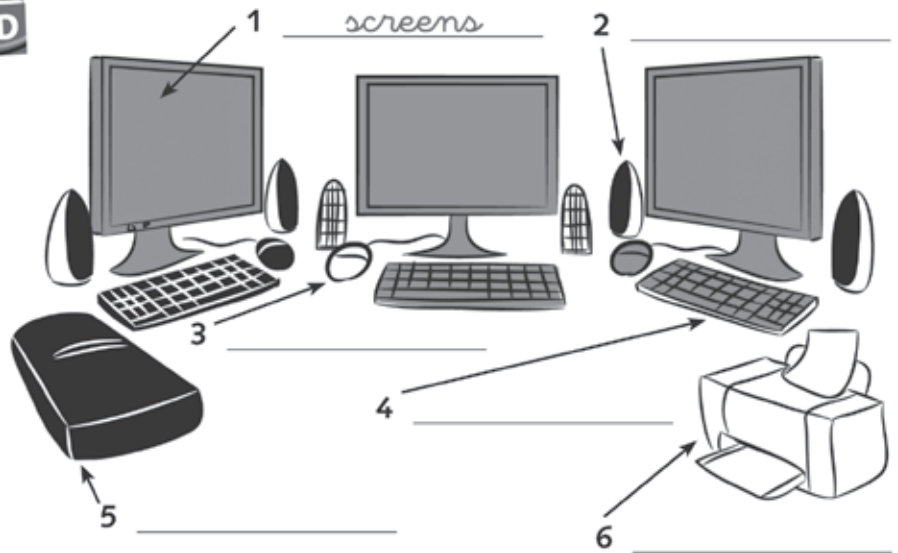

2 Answer.



- 1 What colour is the screen? white
- 2 What colour is the keyboard? _____
- 3 What colour is the mouse? _____
- 4 What colour is the printer? _____
- 5 What colour is the scanner? _____
- 6 What colour are the speakers? _____

3 Write about your computer.

4 Match the instructions with the icons. Then use the underlined words to label the icons.

	<input type="radio"/>	<u>print</u>
	<input type="radio"/>	_____
	<input type="radio"/>	_____

	<input type="radio"/>	_____
	<input type="radio"/>	_____
	<input type="radio"/>	_____

- a Click here to copy some text.
- b Click here to paste some text into your document.
- c Click here to open a new document.
- d Click here if you want to print a document.
- e Click here to delete some text.
- f Click here if you want to save a document.

1 Complete the crossword with the past form of the verbs.

- 1 read
- 2 live
- 3 eat
- 4 ride
- 5 wear
- 6 play
- 7 listen
- 8 take
- 9 paint

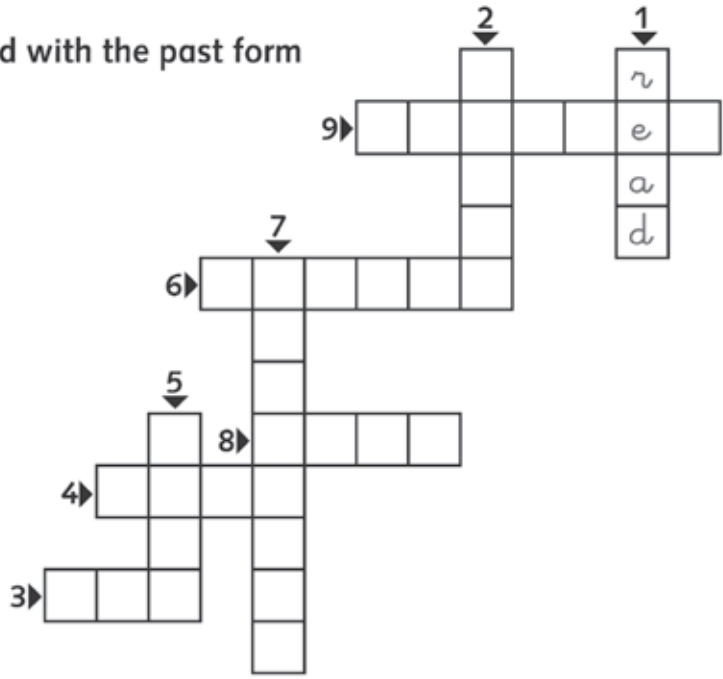

2 Write about life in the Middle Ages. Use the verbs in activity 1.

~~tomatoes~~ meat and vegetables flats ~~small houses~~ horses jeans
 tunics chess to MP3 players photos pictures comics

The Middle Ages was a long period of history, from around 476 to 1492. Life was very different in the Middle Ages.



They didn't eat tomatoes.





They lived in small houses.



















1 Read and write the headings on the Medieval Town leaflet.

Go shopping!

Lessons for boys

Paint like a monk!

Listen to medieval music!

Welcome to the Living Museum. Visit the Medieval Town and discover life in the Middle Ages!

1 Listen to medieval music!

Monks lived in monasteries. Visit the church and listen to the monks singing. The monks went to church eight times a day!



Monks

2 _____

The Medieval school was just for boys – girls didn't go to school in the Middle Ages. They learned to read and write. They didn't study Music or do PE. They studied Mathematics and learned Latin and Greek too.



3 _____



The monks made beautiful books in the monastery. They didn't have computers or printers, so they wrote the books by hand. They also decorated the books with very beautiful pictures.

4 _____

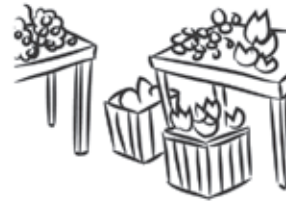

They didn't have supermarkets in the Middle Ages. People went to the market for fruit, meat and vegetables. Are you hungry? Have lunch in our medieval market.

2 Read again. Write *church, monastery, school* or *market*.

Notes for the Medieval Town

1 You can buy toys here. market

5 Girls didn't go here. _____

2 Monks sang songs here. _____

6 You can have lunch here. _____

3 Monks decorated books here. _____

7 People bought fruit here. _____

4 You can hear singing here. _____

8 Boys learned Greek here. _____

3 Write a leaflet for the Roman Town at the Living Museum. 

- 1 Use the notes for the Roman Town.
- 2 Write your text.
- 3 Illustrate your leaflet.

Notes for the Roman town

The baths: different rooms for men and women; good place to meet your friends in the centre of town

The forum: shops; meeting place – like an office

The school: girls didn't go; boys studied Latin, Greek, Maths; lessons sometimes outside

The restaurant: olives and honey; water and wine

1 Write.

visited went made went gave had ~~met~~ wore saw had wrote bought

a good time to the shops a milkshake a film a T-shirt some jeans a pizza
for a walk an art gallery an e-mail a present to Sue ~~a friend~~

Alice, Tom and Joe were busy last Saturday.



Alice met a
friend.



She _____







Tom _____

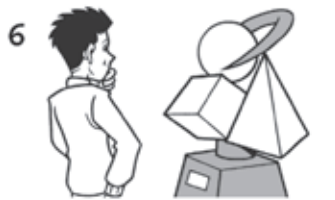







Joe _____







2 Answer.

- 1 Did Alice go to the shops? Yes, she did. 5 Did Tom have a milkshake? _____
2 Did Tom buy some jeans? _____ 6 Did Joe make a pizza? _____
3 Did Joe have a good time? _____ 7 Did Alice see a film? _____
4 Did Alice visit an art gallery? _____ 8 Did Tom write an e-mail? _____

3 Write some more questions about Alice, Tom and Joe.

- 1 _____ ? Yes, she did.
2 _____ ? Yes, he did.
3 _____ ? No, she didn't.
4 _____ ? Yes, he did.

1 Choose three answers for each question.

my friend ~~to the shops~~ an ice cream to the cinema some popcorn
my cousin my mum some shoes to the beach

Where did you go?
<i>to the shops</i>

Who did you meet?

What did you buy?

2 Complete the dialogues. Use the words in activity 1. Use the verbs in the correct form.



1 Where did you go?
I went to the cinema.

2 Who did you meet?

3 What did you buy?



4 Where did you go?

5 Who did you meet?

6 What did you buy?



7 Where _____?
I went to the beach.

8 Who _____?
I met my cousin.

9 What _____?
I bought an ice cream.

3 Think about a day in your life. Draw pictures and complete the dialogues.



Where _____?



Who _____?

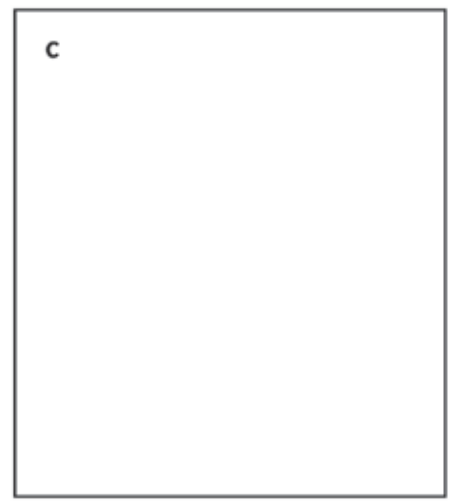

What _____?

1 Find nine more verbs and their Past Simple forms.

g	b	u	y	p	e	m	r
i	n	a	k	d	e	a	t
v	s	k	w	r	o	k	a
e	e	w	r	i	t	e	k
s	e	a	w	n	a	v	e
h	a	v	e	k	e	g	o

b	m	a	d	e	d	e	g
o	n	t	u	a	r	g	a
u	k	e	b	h	a	d	v
g	w	e	n	t	n	s	e
h	t	o	o	k	k	a	o
t	w	r	o	t	e	w	r

2 Read and complete with the correct form of the verbs.



One day Jason (go ✓) ¹ went for a swim in the river in the woods. He (see ✓) ² _____ a monster. He (jump ✓) ³ _____ out of the water and he (run ✓) ⁴ _____ home. He (take ✗) ⁵ didn't take his clothes with him! He (tell ✓) ⁶ _____ his mum about the monster. She was angry. 'Go and find your clothes!' she said.

Jason (have ✓) ⁷ _____ an idea. He (walk ✓) ⁸ _____ back to the woods with his digital camera. He (see ✓) ⁹ _____ the monster again, but he wasn't scared – he was surprised! He (run ✗) ¹⁰ _____. He (climb ✓) ¹¹ _____ a tree and he (wait ✓) ¹² _____. The monster (walk ✓) ¹³ _____ under the tree. Jason (take ✓) ¹⁴ _____ a photo. The monster (see ✓) ¹⁵ _____ the flash and (disappear ✓) ¹⁶ _____.

Jason said, 'Look at the photo. The monster is wearing my clothes!' Jason's mum was very surprised! Jason (give ✗) ¹⁷ _____ the photo to his mum. He put it on his wall. Then he (write ✓) ¹⁸ _____ an e-mail to his friend John about his adventure with the monster.

3 Read the story again. Number the pictures.



1 Complete with two words.

the police some money ~~a poem~~ an e-mail notes a bike hello a horse
a race Maths a door a book History ~~a ball~~ a friend a match

- 1 say a poem / _____
- 2 open _____ / _____
- 3 write _____ / _____
- 4 ride _____ / _____
- 5 win _____ / _____
- 6 find a ball / _____
- 7 study _____ / _____
- 8 phone _____ / _____

2 Write the Past Simple form of the verbs. Use a dictionary. 

Infinitive	Past Simple form	Infinitive	Past Simple form
say	<i>said</i>	win	
open		find	
write		study	
ride		phone	

3 Colour the regular verbs green and the irregular verbs red.

4 Read and write *True* or *False* for you. Then write five more true sentences.

- 1 I didn't find any money in the street yesterday. _____
- 2 I rode my bike yesterday. _____
- 3 I won a match at the weekend. _____
- 4 I didn't study Maths at the weekend. _____
- 5 I phoned my granny yesterday. _____
- 6 _____
- 7 _____
- 8 _____
- 9 _____
- 10 _____

1 Read and answer. 1 Who is the story about? 2 What doesn't she like? 3 Who is Sue?

2 Read again. Complete with the correct form of the verbs.



Elsa (like ✗) ¹ didn't like going to museums, but her parents (love ✓) ² loved them. When they (go ✓) ³ _____ on holiday, they (go ✗) ⁴ _____ to the beach and they (climb ✗) ⁵ _____ mountains. They (go ✓) ⁶ _____ to museums!

Last summer they (visit ✓) ⁷ _____ a dinosaur museum. Her parents (stop ✓) ⁸ _____ by every skeleton. Her mum (read ✓) ⁹ _____ the information and her dad

(take ✓) ¹⁰ _____ photos. Elsa (want ✗) ¹¹ _____ to learn about dinosaurs. 'They're boring', she (think ✓) ¹² _____. 'They (live ✓) ¹³ _____ millions of years ago.' She (watch ✓) ¹⁴ _____ a video about dinosaurs as she (wait ✓) ¹⁵ _____ for her parents. It was the story of a T. Rex and a woman called Sue. Sue Hendrickson (discover ✓) ¹⁶ _____ the skeleton in South Dakota, USA.

Later that year Elsa was in the school team in a TV quiz show. It was the last question.

Elsa's team (have ✓) ¹⁷ _____ 29 points and the other team (have ✓) ¹⁸ _____ 29 points too. The quiz master (ask ✓) ¹⁹ _____ the question: 'Where did Sue Hendrickson discover the famous T. Rex?' The other team (know ✗) ²⁰ _____. Elsa's team (know ✗) ²¹ _____. Then suddenly Elsa (remember ✓) ²² _____ the video. She (push ✓) ²³ _____ the answer button – and they (win ✓) ²⁴ _____ the competition. The prize was a trip to ... the dinosaur museum!

3 Order the words to make questions. Answer.

1 on What holiday did do ? Elsa
What did Elsa do on holiday?
She went to museums.

2 ? museum kind of summer did they
 What visit last

3 dinosaurs did live ? When

4 What watch Elsa did ?

5 discover What did ? Hendrickson Sue

6 points many teams did How have ?
 the

7 the Did answer the team know ?
 other

8 Elsa's win did team What ?

1 Read the story. Number these people in the order they appear.

-  a thief
 Jake
 Sam 1
  the police
 Rosie
 Mrs Black

My name's Sam. Rosie is my neighbour. Last Saturday she went to the park. I went shopping with Mum, but later I went to the park to meet her.



We played tennis in the park with Rosie's brother Jake. Jake hit the ball over the wall into Mrs Black's garden. Mrs Black doesn't like children. She never gives them back their tennis balls.

We didn't want to see Mrs Black. So Rosie climbed over the wall and jumped into the garden. Then she saw a thief. She watched him. He opened a window and climbed into the house.



Rosie thought quickly. She called the police on her mobile phone. They arrived in a police car. They arrested the thief.

Mrs Black invited Rosie into the house. She said thank you to her and she gave her a drink and some biscuits. Then she gave Rosie her tennis ball – and a big bag of other tennis balls too!



2 Read again and answer the questions about Sam's story. Use notes.

	Sam's story	Your story
1 Who is the story about?	Sam, Rosie, Jack, Mrs Black, a thief	
2 When did it happen?		
3 Where did the character go?		
4 What did he/she do there?		
5 What happened?		
6 What did the character see?		
7 What did he/she do?		
8 What happened next?		
9 How did the story end?		

3 Write a story. 

- 1 Plan your story. Answer some or all of the questions in activity 2.
- 2 Use your notes to write your story. Add some interesting information.
- 3 Check your story carefully.
- 4 Write out the corrected text and draw a picture.

1 Write.

mix the lemonade fry the onions peel the lemons bake the pizza
~~chop the tomatoes~~ weigh the sugar boil the water add the cheese



1 chop the tomatoes



2 Look and write. Use *She's got ...* and *She needs ...*

Vegetable and pasta soup

- 3 carrots
- 2 tomatoes
- 2 onions
- 100g pasta
- 100g meat
- 1l water



- | | |
|-----------------------------|---------|
| 1 <u>She's got carrots.</u> | 4 _____ |
| 2 _____ | 5 _____ |
| 3 _____ | 6 _____ |

3 Abbie wants to help her mum make bread and soup. Look and write.



1 I want to mix the flour and water.



3 I don't want to



1 Read the recipe. Correct the mistakes.

How to make a banana milkshake



First you have to wash the bananas.

First you have to peel the bananas.



Then you have to chop the onions.



Then you have to add water and sugar.



Then you have to boil the milkshake.



Then you have to add the strawberries.

2 Look and write about how to make a strawberry milkshake.

add mix add wash

milk sugar milkshake ~~strawberries~~ ice cream



1 First you have to wash the strawberries.



2 _____
3 _____
4 _____

3 Look at the recipes in activities 1 and 2 and write questions and answers.

Yolanda wants to make a strawberry milkshake.

1 Do I have to wash the strawberries? Yes, you do.

2 _____ No, you don't.

3 _____ Yes, you do.







Robert wants to make a banana milkshake.

4 Do I have to peel the bananas? Yes, you do.

5 Do I have to boil the milk? _____

6 Do I have to add sugar? _____

1 Read. Write 6A or 6B by the sentences.

CLASS 6A	9.00	9.45	10.45	11.15	12.30
		$2 + 2 = 4$			1492
CLASS 6B	9.00	9.45	10.45	11.15	12.30
	1492				$2 + 2 = 4$

- 1 I've got English at nine o'clock. 6A 4 I've got PE at quarter to eleven. _____
- 2 I've got Science at quarter to ten. _____ 5 I've got History at nine o'clock. _____
- 3 I've got Maths at half past twelve. _____ 6 I've got ICT at quarter past eleven. _____

2 Write three possible adjectives for each word. You can use these adjectives or think of your own.

boring *nice* *modern* *small* *fun* *old* *easy* **interesting**
big *colourful* *short* *cold* *noisy* *new* *difficult* *red* *white*
green

- 1 your bedroom _____
- 2 your school _____
- 3 your books _____
- 4 your favourite subject _____
- 5 your classroom _____

3 Write dialogues about things in your life.

1  ? ?

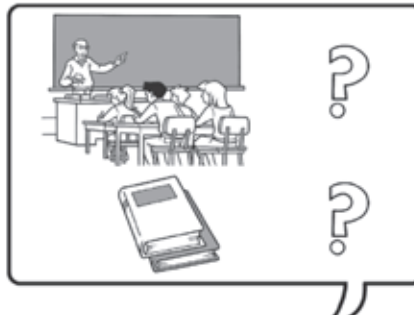
2  ? ?

3  ? ?

What's your school like?
 It's _____

What are the classrooms like?
 They're _____

What's your teacher like?

What are your books like?

What's your bedroom like?

What's your bed like?

1 Write. Use your dictionary. **D**

- 1 _____
- 2 _____
- 3 *fork* _____
- 4 _____

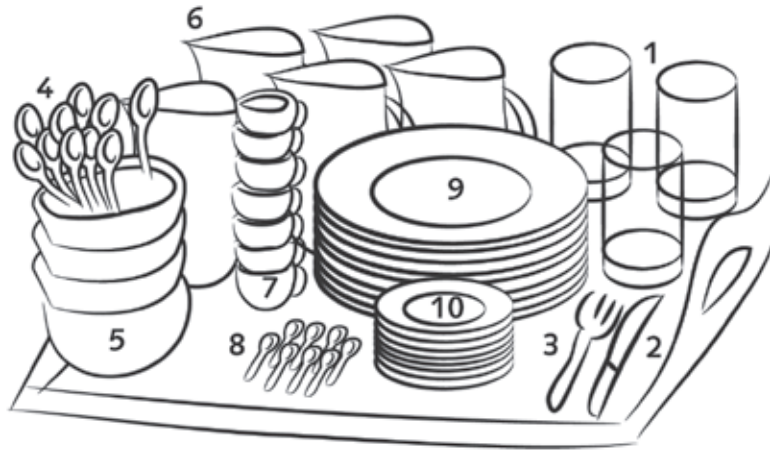

- 7 _____
- 8 _____
- 9 _____
- 10 _____

2 Compare with activity 1. Write.



He needs a knife, a bowl, a cup and a jug. _____

3 Read. Write *True* or *False*. Then write three more true sentences. **D**

- 1 Plates are usually made of china. True
- 2 Knives are usually made of glass. _____
- 3 Glasses are made of wood. _____
- 4 Trays are sometimes made of plastic. _____
- 5 Forks are usually made of metal. _____
- 6 _____
- 7 _____
- 8 _____

1 Match. Then write three sentences about your classes.

- | | | |
|----------------------------|----------------------------------|--|
| 1 In Maths you have to | <input checked="" type="radio"/> | a learn different computer programmes. |
| 2 In Art you have to | <input type="radio"/> | b read maps. |
| 3 In PE you have to | <input type="radio"/> | c draw graphs. |
| 4 In Geography you have to | <input type="radio"/> | d play volleyball. |
| 5 In History you have to | <input type="radio"/> | e do experiments. |
| 6 In ICT you have to | <input type="radio"/> | f make sculptures. |
| 7 In Science you have to | <input type="radio"/> | g learn about the Romans. |



- 8 _____
- 9 _____
- 10 _____

2 Match. Then answer the questions for your country.

Yes, you do. No, you don't. Yes, they do. No, they don't.

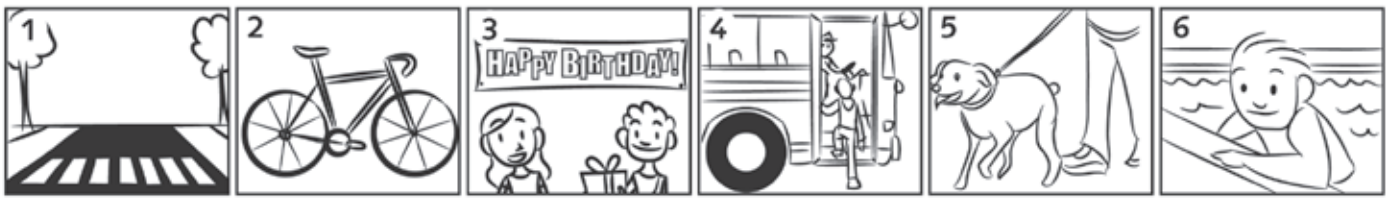

- | | |
|--|--|
| a Do you have to learn to swim? <input checked="" type="radio"/> | d Do dogs have to have a lead? <input type="radio"/> |
| b Do you have to buy a ticket? <input type="radio"/> | e Do cars have to stop? <input type="radio"/> |
| c Do you have to wear a helmet? <input type="radio"/> | f Do you have to give a present at birthday parties? <input type="radio"/> |

3 Order the words to make a question. Then answer for you.

- | | | |
|---|--|-------|
| 1 | every day a shower you Do have to have ? | _____ |
| 2 | Do your pet have to you feed ? | _____ |
| 3 | vegetables eat you have to Do ? | _____ |
| 4 | Do plants you the water have to ? | _____ |

1 Read the tourist guide. Circle the topics you read about.

hotels health sport culture food pets people school beaches transport

Planet Travel Guide 3010

Are you thinking of visiting VPZ59? Here are five top tips for visitors.



1 VPZ59 has got two suns and it's very hot. The sun's radiation is dangerous for Earthlings. All visitors from Earth have to use a special cream.



2 VPZ59ers are very friendly, but you have to know what to do when you meet them. If you want to make friends, you have to learn how to say hello!





3 You can find fantastic things to eat. VPZ59 is famous for its vipi fruits. They are big, blue and delicious. You have to try them!

vipi fruit

4 It's easy to travel on VPZ59. There are transporter stations on every street. You have to buy a ticket. Then you stand in the transporter and say where you want to go. In 15 seconds, you're there!



Transporter Station

5 You have to watch a VPZball match. There are two teams of 11 people. They play with a ball. They can't touch the ball with their hands. They have to put the ball in a net. It's strange, but it's fun!



net

2 Look at the tourist guide again. Complete the notes.

Health – the sun is ¹ hot – visitors have to use ² _____.

People – VPZ59ers are ³ _____ – you have to know how to ⁴ _____.

Food – the food is ⁵ _____ – ⁶ _____ are big
⁷ _____, ⁸ _____.

Transport – easy – ⁹ _____ stations – ¹⁰ _____ a ticket –
¹¹ _____ your destination.

Sport – VPZball – two teams of ¹² _____ – can't touch the ball with their
¹³ _____, put the ball into a ¹⁴ _____.

3 Write a tourist guide for a planet. 

- 1 Imagine your planet. Write notes about some of these things:
 - health
 - pets
 - food
 - transport
 - sport
 - school
 - culture
 - beaches
 - hotels
 - good manners
- 2 Choose the five most interesting areas. Write your tips.
- 3 Check your work carefully.
- 4 Write your tourist guide. Draw some pictures.

1 Write.

waterfall river island beach rock cliff hill cave mountain wood

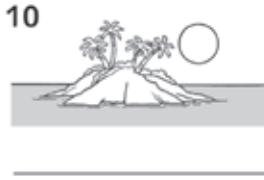
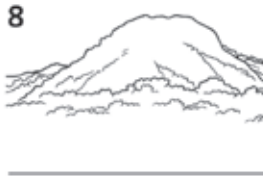
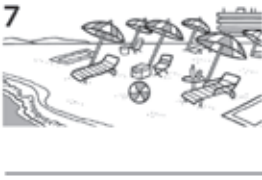
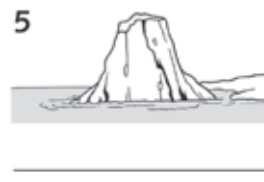
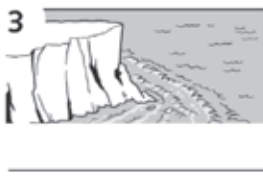

2 Compare the places. Write eight things that are different in picture B.

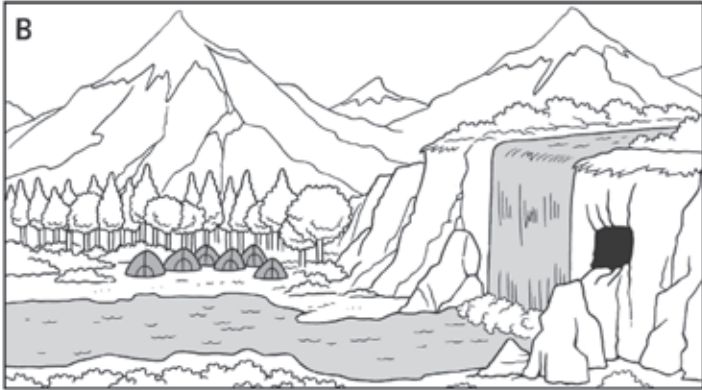

There's a... There are some...
There isn't a... There aren't any...

- 1 There aren't any hills.
- 2 _____
- 3 _____
- 4 _____
- 5 _____
- 6 _____
- 7 _____
- 8 _____

3 Read and write A or B. Then write four more questions about the pictures.

- | | |
|--|--|
| 1 Are there any hills?
Yes, there are. Picture <u>A</u> | 5 _____
Yes, there is. Picture A |
| 2 Is there a cave?
Yes, there is. Picture _____ | 6 _____
Yes, there are. Picture B |
| 3 Are there any rocks?
No, there aren't. Picture _____ | 7 _____
No, there aren't. Picture A |
| 4 Is there a waterfall?
No, there isn't. Picture _____ | 8 _____
No, there isn't. Picture B |

1 Complete.

a mountain homework an e-mail a bike
in the park in a lake ~~television~~ in my bed

- 1 watch television
- 2 do _____
- 3 swim _____
- 4 sleep _____

- 5 climb _____
- 6 run _____
- 7 ride _____
- 8 read _____

2 Read and answer.



Amy

Amy is going to climb a mountain. She's going to sleep in a tent. She isn't going to play computer games. She's going to read books.



Clare

Clare is going to visit her grandparents. She's going to read books and play computer games. She's going to play volleyball.



Grace

Grace is going to go to the beach. She isn't going to sleep in a tent. She's going to swim in the sea and play volleyball.



Fiona

Fiona is going to go camping. She's going to sleep in a tent. She's going to swim in a river.

- 1 Who's going to sleep in a tent and swim? Fiona
- 2 Who's going to sleep in a tent and read books? _____
- 3 Who's going to play volleyball and swim? _____
- 4 Who's going to read books and play volleyball? _____

3 Write about what Ben and Jackie are going to do tomorrow.

Ben

Jackie

- 1 Ben is going to read a book.
- 2 He isn't going to _____
- 3 _____
- 4 _____
- 5 Jackie _____
- 6 _____
- 7 _____
- 8 _____

1 Write.

go sailing do card tricks ~~design a web page~~ go canoeing juggle
make cakes go scuba diving

What are you going to do at summer camp?



4



5



6



7



1 I'm going to design a web page.

2 _____

3 _____

4 _____

5 _____

6 _____

7 _____

2 Read and write the names. Then write two more dialogues about the other people.



Ella



Paul



Sandra



Tom



Jamie

1

Where are you going to go?
I'm going to go to the beach.
What are you going to do?
I'm going to go canoeing.
Tom

2

Where are you going to go?
I'm going to go to the beach.
What are you going to do?
I'm going to go scuba diving.

3

Where are you going to go?
I'm going to go to summer camp.
What are you going to do?
I'm going to do card tricks.

4

5

1 Write. Use your dictionary. **D**

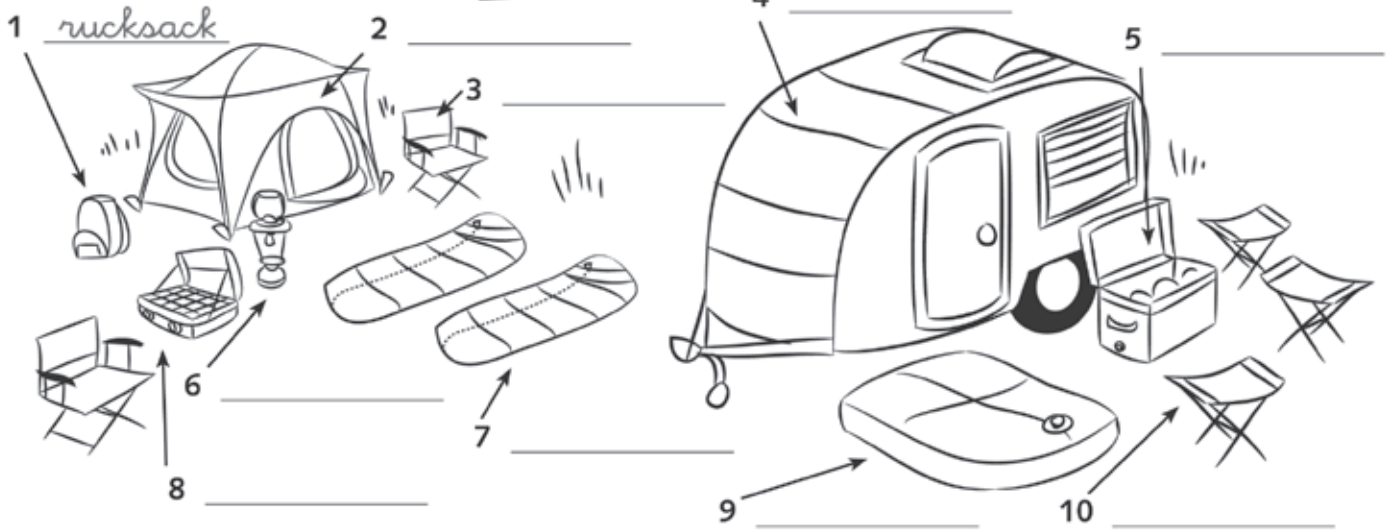

2 Look at activity 1. Write *True* or *False*. Correct the false sentences.

Look at the tent.

- 1 There are two sleeping bags. True
- 2 The rucksack is beside the tent. _____
- 3 There's a coolbox. _____
- 4 They've got two chairs. _____
- 5 They haven't got a lamp. _____
- 6 _____
- 7 _____

Look at the caravan.

- 8 The caravan is smaller than the tent. _____
- 9 They've got an airbed. _____
- 10 They've got a stove. _____
- 11 There are three stools. _____
- 12 They haven't got a lamp. _____
- 13 _____
- 14 _____

3 Complete the dialogues.

1

Camping list

- tent
- lamp
- sleeping bags
- rucksack

Have you got the lamp?
 Yes, I have.

Have you got the tent?

Have you got the sleeping bags?

Have you got the rucksack?

2

Camping list

- airbeds
- coolbox
- stools
- stove

_____?

Yes, I have.

_____?

No, I haven't.

_____?

Yes, I have.

_____?

No, I haven't.

1 Write two sentences for each picture. Use your dictionary. **D**

towel laptop ~~ticket~~ mobile phone

take a photo ✓ phone a friend ✗ write an e-mail ✗ ~~theatre~~ ✗
 go swimming ✓ have a shower ✗ watch a video ✓ ~~pop concert~~ ✓



He's got a ticket. He isn't going to the theatre, he's going to a pop concert.







2 Write the questions. Match and write the complete answer.

1 are Where going you to ? tomorrow go
Where are you going to go tomorrow?

a Sam

2 ? go are going to How you

b some jeans

3 to are Who you meet ? going

c by bus

4 going What you ? buy to are

d at a café

5 have lunch to ? are Where you going

e to the shopping centre

6 time are you What to leave ? going

I'm going to go to the shopping centre.

f eight o'clock

1 Read the article. Answer the questions.

- 1 What did Eva win?
- 2 Where does Eva find her ideas?
- 3 Where is Eva going to go?



Oxford Voice: Eva, when did you start making videos?

Eva: I started about three years ago. My mobile phone has a video camera and I started making mini films with it.

Oxford Voice: How do you think of an idea for a film?

Eva: Well, I often find ideas in newspapers. Then I talk to my friends and we invent the story together.

Oxford Voice: Were you surprised to win the award?

Eva: Yes, I was - very! And now I'm very excited.

The winner is ... Eva Taylor!

The Oxford Voice interviewed Eva Taylor, the winner of this year's Student Video competition. The award is for the best video made by students. Eva and her team made a short film of a detective story. They wrote the story and planned the film. They used their friends as actors and they made the film at their homes and in their gardens. The famous actor Christine Moore said, 'Eva worked very hard and the film is fantastic!'

Oxford Voice: Why?

Eva: Because the prize is a trip to Hollywood for me and the team. We're going to go in a jumbo jet - first class! Then we're going to visit the most important studios. We're going to watch a film by my favourite director, Billy Benson. I think he's amazing.

Oxford Voice: That's great. Congratulations, and have a good time!

2 Read the article again. Answer the questions with notes.

	The <i>Oxford Voice</i> article	Your article
1 What is the award for?	<i>Student video competition</i>	
2 Who won the award and why?		
3 How does the award winner feel?		
4 What is the prize?		
5 What plans does the award winner have?		

3 Write an article about an award. 

- 1 Invent the name of your newspaper.
- 2 Complete the column in activity 2 for your award.
- 3 Write your article. Include some other interesting information.
- 4 Correct your article.
- 5 Write out the corrected text and draw a picture.

OXFORD

UNIVERSITY PRESS

Great Clarendon Street, Oxford OX2 6DP

Oxford University Press is a department of the University of Oxford.

It furthers the University's objective of excellence in research, scholarship, and education by publishing worldwide in

Oxford New York

Auckland Cape Town Dar es Salaam Hong Kong Karachi Kuala Lumpur Madrid Melbourne Mexico City Nairobi New Delhi Shanghai Taipei Toronto

With offices in

Argentina Austria Brazil Chile Czech Republic France Greece Guatemala Hungary Italy Japan Poland Portugal Singapore South Korea Switzerland Thailand Turkey Ukraine Vietnam

OXFORD and OXFORD ENGLISH are registered trade marks of Oxford University Press in the UK and in certain other countries

© Oxford University Press 2015

The moral rights of the author have been asserted

Database right Oxford University Press (maker)

NO COPYING EXCEPT AS PERMITTED BELOW, NO FILE SHARING

This resource is protected by international copyright laws. You must not modify, adapt, copy, store, transfer or circulate the contents of this resource under any other branding or as part of any other product. You may not print out material for any commercial purpose or resale

PHOTOCOPYING

The publisher grants permission for the photocopying of those pages marked 'photocopiable' according to the following conditions. Individual purchasers may make copies for their own use or for classes that they teach. School purchasers may make copies for use by staff and students, but this permission does not extend to additional schools or branches

ACKNOWLEDGEMENTS

Author: Carol Barrett

Illustrations by: Sean Longcroft: Reinforcement worksheets;
Christos Skaltsas: Extension worksheets.

The Publisher advises that activities involving cutting and sticking should be carried out under the supervision of an adult.